

STANDARD CYLINDER

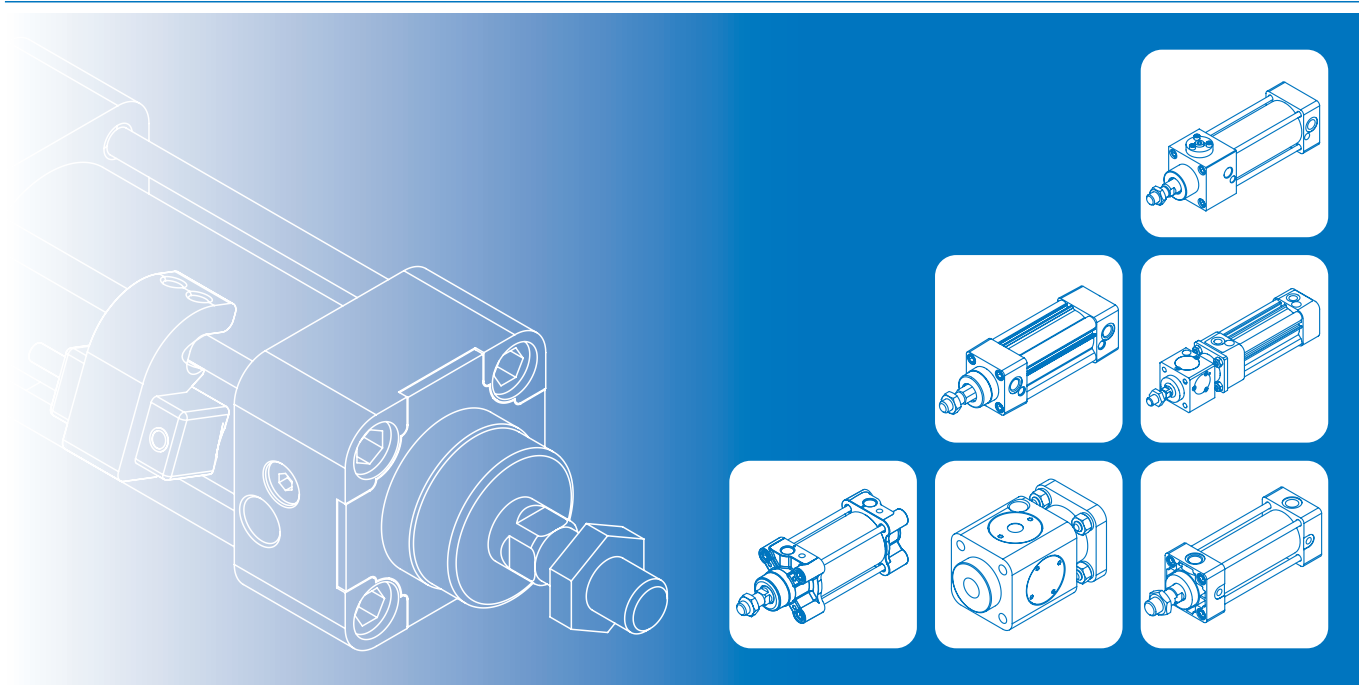

	STANDARD CYLINDER	
MCQA	ø40~ø200.....	1-2
MCQA-AH	ø40~ø150.....	1-22
MCQN	ø1 1/2"~ø4".....	1-25
	ISO 15552 STANDARD CYLINDER	
MCQV	ø125~ø200.....	1-32
MCQV3	ø32~ø100.....	1-44
MCQVS	ø32~ø100 Stainless steel	1-61
	END LOCK CYLINDER	
MCQV3L	ø63, ø80.....	1-72
	ISO 15552 STANDARD PROFILE CYLINDER	
MCQI3	ø32~ø100.....	1-78
MCKQI3	ø32, ø40 No Rotating.....	1-94
	ROD LOCKING CYLINDER	
MCB*	ø20~ø125.....	1-98
MCB	ø20~ø125.....	1-101
	POWER CYLINDER	
MHPD	1-104



Special spec



Rod end shape



Technical data



Caution for safety

(Read before installing)

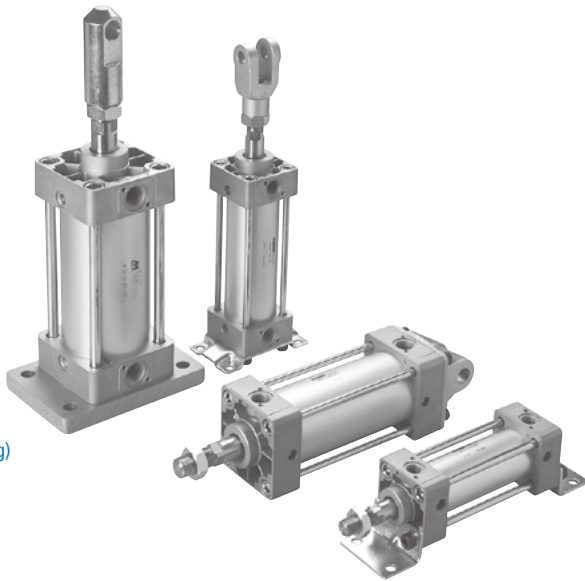

Features

■ Non lubrication

Special housing and bushing enables self lubrication of piston rod.

■ High quality long service life

Hard anodised aluminium cylinder tubes offer a high resistance to corrosion and low internal friction.

■ Non standard type

Custom cylinders are available as are non standard strokes, rod extensions and special rod threads.

■ Cylinder mountings

Available with comprehensive internationally recognised range of fixed and flexible mountings.

Specification



Model	MCQA				
Tube I.D. (mm)	40,50,63	80,100	125	150	200
Medium	Air				
Operating pressure range	0.05~1 MPa				
Proof pressure	1.5 MPa				
Ambient temperature	-5~+60°C (No freezing)				
Available speed range	50~500 mm/sec				
Sensor switch	RDC(V), RQC(V) 				RDT, RQT 
	RCA 				
Sensor switch holder	R*C(V)	DT7-1	DT7-3		-
	R*T	-			DT-5
	RCA	HV2	HV4	PM14	PM16

Table for standard stroke

Tube I.D.	Stroke (mm)	Max. stroke (mm)	
		Style 11	Style 21/27
ø40	50,75,100,125,150, 175,200,250,300, 400,500	1800	850
ø50,63		2000	950
ø80,100		2500	1200
ø125,150		2000	950
ø200		1500	700

* Intermediate stroke are available, please contact us.

Order example

MCQA - 11 - 40 - 100M - T - □

MODEL

1: Single rod
2: Double rod

TUBE I.D.

STROKE

M: Magnet

PORT THREAD

Blank: Rc thread
G: G thread
NPT: NPT thread

STYLE

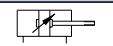
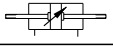
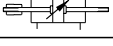
Code	Symbol	Description
1 1		Double acting / Male thread
2 1		Double rod / Male thread
2 7		Double rod / Adjustable male thread Please mark "adjustable stroke" at order list







TYPE

T: With magnet, TA/TB is assembled







* Tube, piston rod and tie rod are extended, and an extra piston is added.

Accessories & Connector

Accessories Δ $\phi 125\sim\phi 200$: Factory assembled and shipped (self-assembled is not recommended)

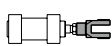
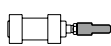

Code	LB (Purchase 2 pcs)	CA	CB	FA	FB	FAC	FBC
Mounting Tube I.D.							
$\phi 40$	LB-Q1-40	CA-Q1-40	CB-Q1-40	FA-Q1-40		FAC-Q1-40	
$\phi 50$	LB-Q1-50	CA-Q1-50	CB-Q1-50	FA-Q1-50		FAC-Q1-50	
$\phi 63$	LB-Q1-63	CA-Q1-63	CB-Q1-63	FA-Q1-63		FAC-Q1-63	
$\phi 80$	LB-Q1-80	CA-Q1-80	CB-Q1-80	-		FAC-Q1-80	
$\phi 100$	LB-Q1-100	CA-Q1-100	CB-Q1-100	-		FAC-Q1-100	
$\phi 125$	LB-Q1-125	CA-Q1-125	CB-Q1-125	-		FAC-Q1-125	
$\phi 150$	LB-Q1-150	CA-Q1-150	CB-Q1-150	-		FAC-Q1-150	
$\phi 200$	LB-Q1-200	CA-Q1-200	CB-Q1-200	-		FAC-Q1-200	

Accessories Δ Factory assembled and shipped (self-assembled is not recommended)

Code	TA	TB	TC	SDS Mid section support (Stroke over 1000mm)	Connector		Rod nut
					Y	I	NUT
Mounting Tube I.D.							
$\phi 40$		TC-Q1-40		SDS-Q1-40	Y-Q1-40	I-Q1-40	NUT-M14x1.5x8Hx22B
$\phi 50$		TC-Q1-50		SDS-Q1-50	Y-Q1-50	I-Q1-50	NUT-M18x1.5x11Hx26B
$\phi 63$		TC-Q1-63		SDS-Q1-63			
$\phi 80$		TC-Q1-80		SDS-Q1-80	Y-Q1-80	I-Q1-80	NUT-M22x1.5x13Hx32B
$\phi 100$		TC-Q1-100		SDS-Q1-100	Y-Q1-100	I-Q1-100	NUT-M26x1.5x14Hx35B
$\phi 125$		TC-Q1-125		SDS-Q1-125	Y-Q1-125	I-Q1-125	NUT-M30x1.5x15Hx41B
$\phi 150$		TC-Q1-150		SDS-Q1-150	Y-Q1-150	I-Q1-150	
$\phi 200$		TC-Q1-200		SDS-Q1-200	Y-Q1-200	I-Q1-200	

Pin

Applicable Y&I connector CA&CB accessories

Code	PIN-Y-P (with split pin)	PIN-CB-P (with split pin)
Fig Tube I.D.		
$\phi 40$	PIN-Q1-50-1-P	PIN-Q1-40-1-P
$\phi 50$		PIN-Q1-50-1-P
$\phi 63$		PIN-Q1-63-1-P
$\phi 80$	PIN-Q1-80-2-P	PIN-Q1-80-1-P
$\phi 100$	PIN-Q1-80-1-P	PIN-Q1-100-1-P
$\phi 125$	PIN-Q1-125-2-P	PIN-Q1-125-1-P
$\phi 150$	PIN-Q1-125-1-P	PIN-Q1-150-1-P
$\phi 200$	PIN-Q1-200-1-P	PIN-Q1-200-1-P

Order example of self-assembled

The tube I.D. $\phi 63$ of LB accessories, Y connector and pin.

No.	Order number	Qty
1	LB-Q1-63	2
2	Y-Q1-63	1
3	PIN-Q1-50-1-P	1

* To order accessories/ connectors/ pin separately, please place orders separately according to the order codes in the above table.

Order example of factory assembled

Δ Cylinders and accessories are distinguished by the symbol " + ".

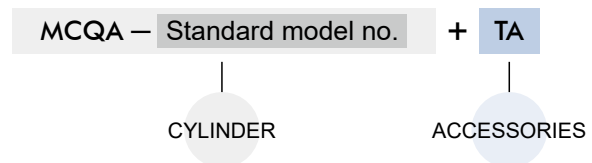

MCQA-11 Inside structure & Part list

STANDARD CYLINDER



Single rod 11 type

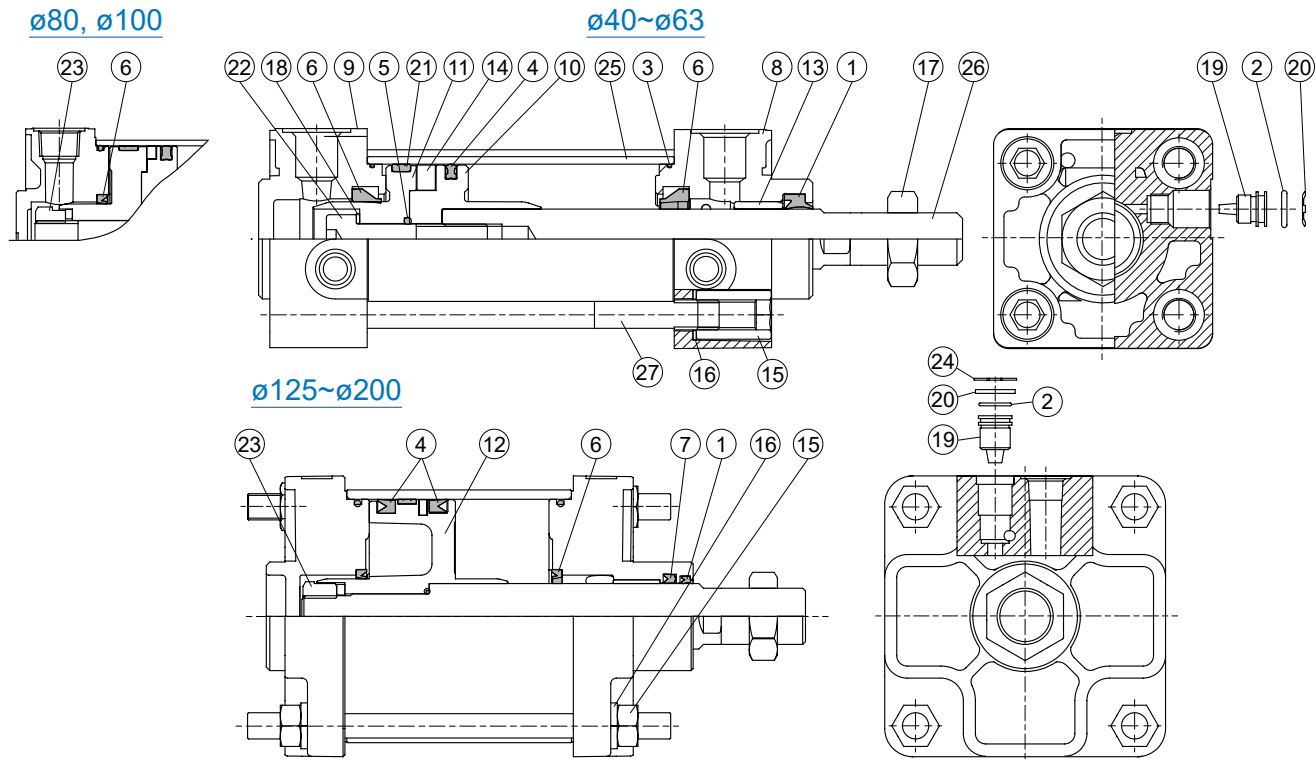

No.	Part name	Material	Q'y	Component parts (inclusion)		Repair kits (inclusion)	Note
				ø40~ø100	ø125~ø200		
1	Rod packing	NBR	1	●	●	●	
2	O-ring	NBR	2	●	●	●	
3	O-ring	NBR	2	●	●	●	
4	Piston packing	NBR	1 or 2	●	●	●	ø125~ø200 (Q'y=2)
5	O-ring	NBR	1	●	●	●	
6	Cushion packing	NBR	2	●	●	●	Repair kits ø40~ø80 (inclusion)
7	Rod packing	NBR	1		●	●	
8	Rod cover	Aluminum alloy	1	●	●		
9	Head cover	Aluminum alloy	1	●	●		
10	Piston-R	Aluminum alloy	1	●			
11	Piston-H	Aluminum alloy	1	●			
12	Piston	Aluminum alloy	1		●		
13	Bush	Bearing alloy	1	●	●		
14	Magnet ring	Magnet material	1	◎	◎		◎ Option
15	Tie rod nut	Carbon steel	8	●	●		
16	Tie rod washer	Carbon steel	8	●	●		
17	Rod nut	Carbon steel	1	●	●		
18	Washer	Carbon steel	1	●	●		
19	Needle valve	Copper alloy	2	●	●		
20	Needle valve washer	*1	2	●	●		
21	Wear ring	Resin	1	●	●		
22	Bolt	Carbon steel	1	●			for ø40~ø63
23	Piston nut	Carbon steel	1		●		for ø80~ø200
24	Snap ring	Carbon steel	2		●		
25	Cylinder tube	Aluminum alloy	1				
26	Piston rod *2	Carbon steel	1				
27	Tie rod	Carbon steel	4				

*1. ø40~ø100: Spring steel, ø125~ø200: Carbon steel

*2. When customized material is bearing steel, only two-side across flat (wrench flat) is available.

MCQA-2* Inside structure & Part list

STANDARD CYLINDER



A: $\phi 40\sim\phi 100$

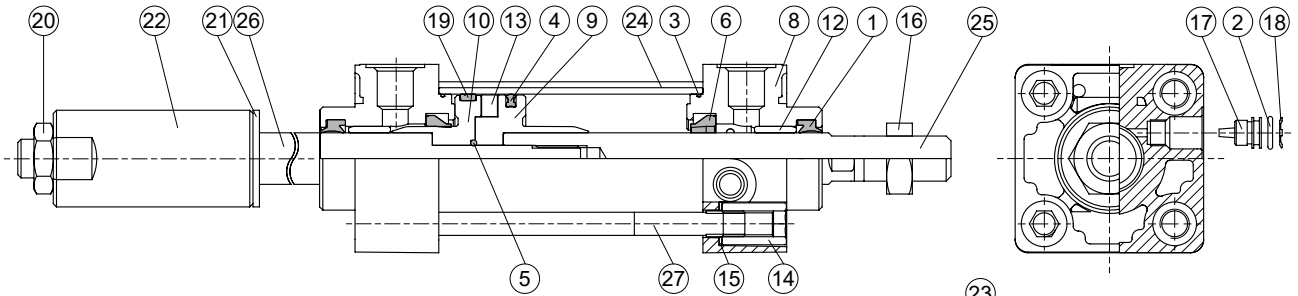

B: $\phi 125\sim\phi 200$

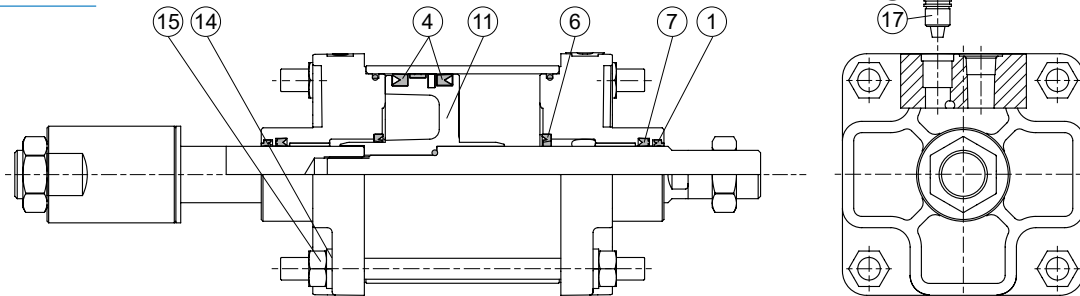

No.	21 type		27 type		Part name	Material	Q'y	Component parts (inclusion)		Repair kits (inclusion)		Note
	A	B	A	B				$\phi 40\sim\phi 100$	$\phi 125\sim\phi 200$	$\phi 40\sim\phi 100$	$\phi 125\sim\phi 200$	
1	●	●	●	●	Rod packing	NBR	2	●	●	●	●	
2	●	●	●	●	O-ring	NBR	2	●	●	●	●	
3	●	●	●	●	O-ring	NBR	2	●	●	●	●	
4	●	●	●	●	Piston packing	NBR	1 or 2	●	●	●	●	$\phi 125\sim\phi 200$ (Q'y=2)
5	●	●	●	●	O-ring	NBR	1	●	●	●	●	
6	●	●	●	●	Cushion packing	NBR	2	●	●	●	●	Repair kits $\phi 40\sim\phi 80$ (inclusion)
7		●		●	Rod packing	NBR	2		●		●	
8	●	●	●	●	Rod cover	Aluminum alloy	2	●	●			
9	●		●		Piston-R	Aluminum alloy	1	●				
10	●		●		Piston-H	Aluminum alloy	1	●				
11		●		●	Piston	Aluminum alloy	1		●			
12	●	●	●	●	Bush	Bearing alloy	2	●	●			
13	◎	◎	◎	◎	Magnet ring	Magnet material	1					◎ Option
14	●	●	●	●	Tie rod nut	Carbon steel	8	●	●			
15	●	●	●	●	Tie rod washer	Carbon steel	8	●	●			
16	●	●	●	●	Rod nut	Carbon steel	1	●	●			
17	●	●	●	●	Needle valve	Copper alloy	2	●	●			
18	●	●	●	●	Needle valve washer	*1	2	●	●			
19	●	●	●	●	Wear ring	Resin	1	●	●			
20	●	●	●	●	Hex nut	Carbon steel	1	●	●			
21			●	●	Gasket	PU	1					
22			●	●	Adjustable nut	Carbon steel	1					
23		●		●	Snap ring	Carbon steel	2		●			
24	●	●	●	●	Cylinder tube	Aluminum alloy	1					
25	●	●	●	●	Piston rod #1 *2	Carbon steel	1					
26	●	●	●	●	Piston rod #2 *2	Carbon steel	1					
27	●	●	●	●	Tie rod	Carbon steel	4					

A: $\phi 40\sim\phi 100$, B: $\phi 125\sim\phi 200$

*1. $\phi 40\sim\phi 100$: Spring steel, $\phi 125\sim\phi 200$: Carbon steel

*2. When customized material is bearing steel, only two-side across flat (wrench flat) is available.

STANDARD CYLINDER

Order example of component parts

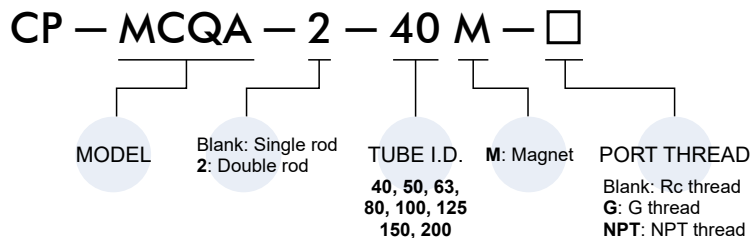

Order example of repair kits

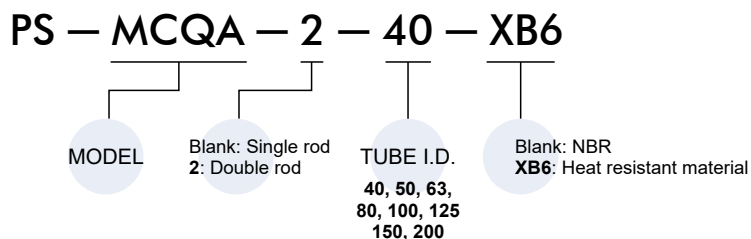

Cylinder & accessories weight





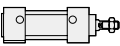
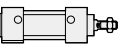
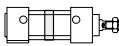





Cylinder weight

Unit: kg

Model	Basic weight MCQA-11	Basic weight (magnet) MCQA-11	Stroke 25 mm MCQA-11
Tube I.D.			
ø40	0.76	0.772	0.09
ø50	1.07	1.087	0.12
ø63	1.46	1.480	0.13
ø80	2.71	2.737	0.22
ø100	3.97	4.005	0.28
ø125	6.99	7.033	0.46
ø150	10.33	10.410	0.55
ø200	19.00	19.144	0.65

Accessories weight

Unit: kg

Model	LB	CA	CB	FA/FB	FAC/FBC	TA/TB/TC	SDS	Y	I	Pin		Rod nut
										CA/CB	Y / I	
Tube I.D.												
ø40	0.213	0.297	0.295	0.162	0.482	0.420	0.262	0.200	0.158	0.025	0.043	0.020
ø50	0.237	0.411	0.407	0.184	0.584	0.455	0.305	0.285	0.222	0.043	0.043	0.030
ø63	0.446	0.630	0.650	0.346	1.012	0.815	0.572	0.285	0.222	0.097	0.043	0.030
ø80	0.951	1.192	1.178	–	1.922	1.600	1.112	0.518	0.485	0.183	0.134	0.050
ø100	1.212	1.820	1.822	–	2.490	2.380	1.787	0.746	0.670	0.308	0.183	0.060
ø125	1.321	3.412	4.059	–	4.224	3.940	3.312	1.680	1.070	0.372	0.211	0.082
ø150	2.638	5.623	5.939	–	6.437	5.300	4.392	1.630	1.730	0.571	0.372	0.082
ø200	5.083	11.456	11.863	–	13.447	14.720	10.866	3.340	3.010	0.988	0.988	0.501

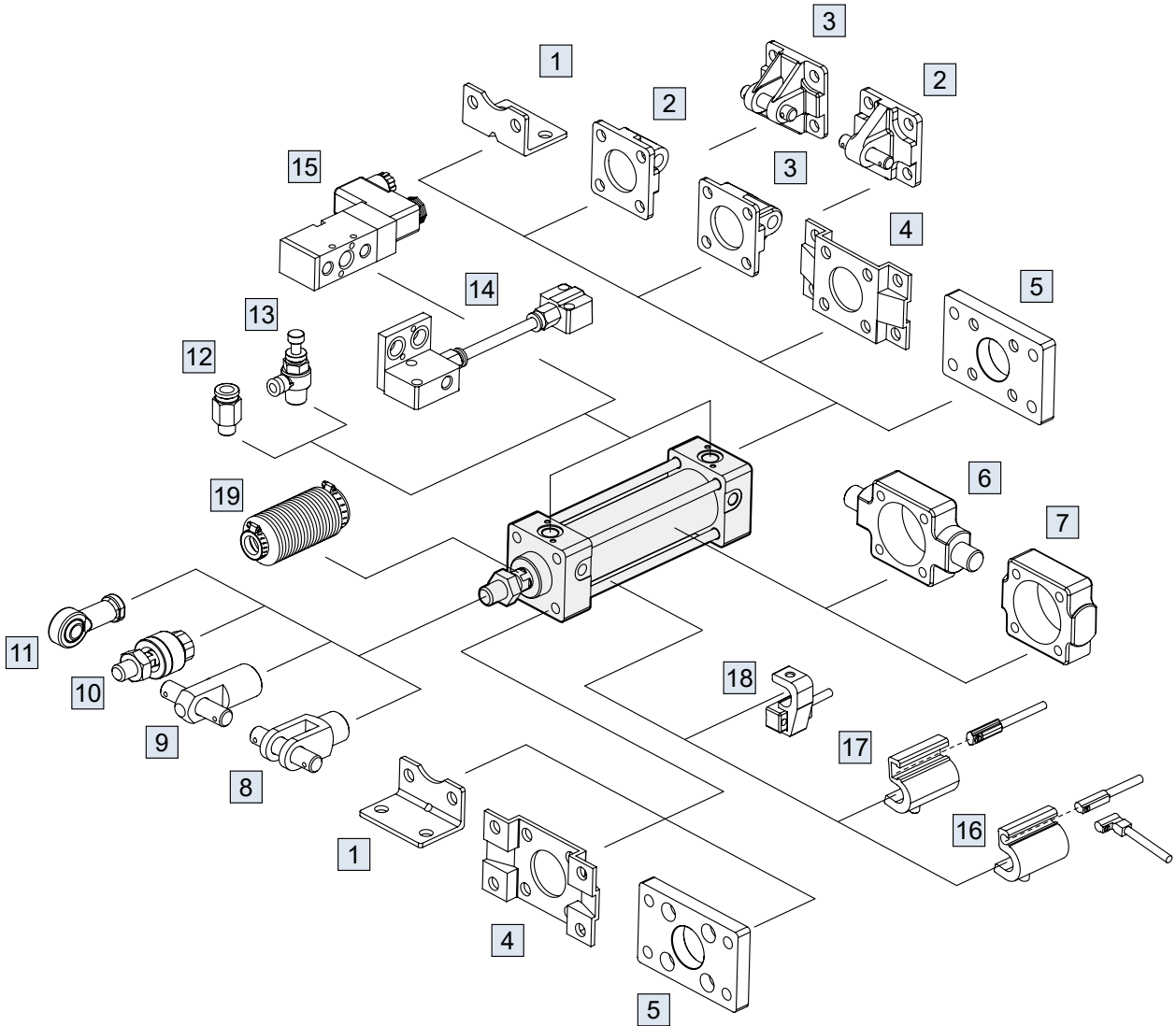

No.	Accessories	Material	Page link
1	Mounting accessories LB	Carbon steel	↗ , ↘
2	Mounting accessories CA+PIN	Cast iron / *	↗ , ↘ , ↙
3	Mounting accessories CB+PIN	Cast iron / *	↗ , ↘ , ↙
4	Mounting accessories FA/FB	Carbon steel	↗
5	Mounting accessories FAC/FBC	Carbon steel	↗ , ↘
6	Mounting accessories TA/TB/TC	Cast iron	↗ , ↘ , ↙ , ↚
7	Mounting accessories SDS	Cast iron	↗ , ↘
8	Accessories Y+PIN	Cast iron / *	↗
9	Accessories I+PIN	Carbon steel	↗

* PIN material is carbon steel.

No.	Accessories	Material	Page link
10	Floating joint MFC	Carbon steel	↗
11	Female rod ends PHS	Carbon steel	↗
12	Fitting PC (PISCO)	—	↗
13	Speed controller JSC (PISCO)	—	↗
14	Solenoid valve link seats VR/VH	Aluminum alloy	↗
15	Solenoid valve MVSC-260/300	—	↗ , ↘
16	Sensor switch R*C(V)+DT7-*	—	↗
17	Sensor switch R*T+DT-*	—	↗
18	Sensor switch RCA+HV*	—	↗
19	Protective bellows kit	NBR	—

STANDARD CYLINDER

mindman

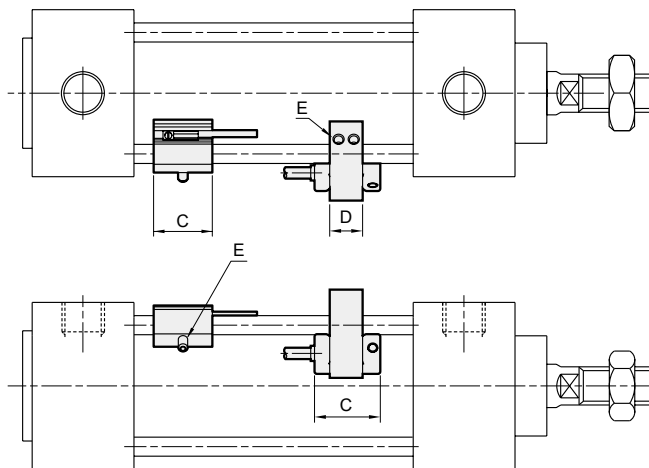
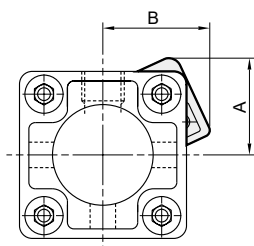
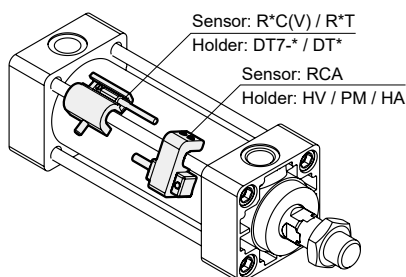

Code Tube I.D.	Sensor switch	Holder	A	B	C	D	E
40	RCA	HV2	36	41	26	13	M4×10L
50	RCA	HV2	38	43	26	13	M4×10L
63	RCA	HV2	46	49	26	13	M4×10L
80	RCA	HV4	52	55	26	13	M4×10L
100	RCA	HV4	59	62	26	13	M4×10L
125	RCA	PM14	—	—	26	12	M4×10L
150	RCA	PM16	—	—	26	12	M4×10L
200	RCA	HA5	—	—	26	15	M4×10L

Code Tube I.D.	Sensor switch	Holder	A	B	C	E
40	R^C(V)	DT7-1	28	28.5	25	M4×12L
50	R^C(V)	DT7-1	32	32.5	25	M4×12L
63	R^C(V)	DT7-1	37.5	38.5	25	M4×12L
80	R^C(V)	DT7-3	49	51.5	25	M4×12L
100	R^C(V)	DT7-3	57	59.5	25	M4×12L
125	R^C(V)	DT7-3	69.5	71	25	M4×12L
150	R^C(V)	DT7-3	79	79	25	M4×12L
200	R^T	DT-5	109	112.5	25	M4×12L

■ Mounting accessories

LB

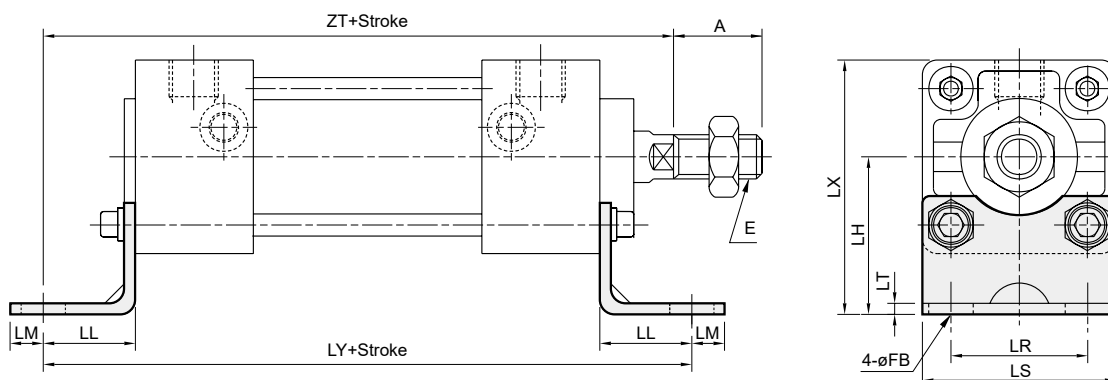

Code Tube I.D.	A	E	FB	LH	LL	LM	LR	LS	LT	LX	LY	ZT
40	30	M14×1.5	9	40	27	13	42	58	3.2	69	138	132
50	35	M18×1.5	9	45	27	13	50	66	3.2	78	144	140
63	35	M18×1.5	11.5	50	34	16	59	80	4.5	90	166	155
80	40	M22×1.5	14	65	44	16	76	100	6	115	204	191
100	40	M26×1.5	14	75	43	17	92	118	6	134	212	201

FA

Note. This type is applied to the cylinder which the stroke is within 500mm.
If the stroke is over 500mm, we advise to choose the **FAC** type.

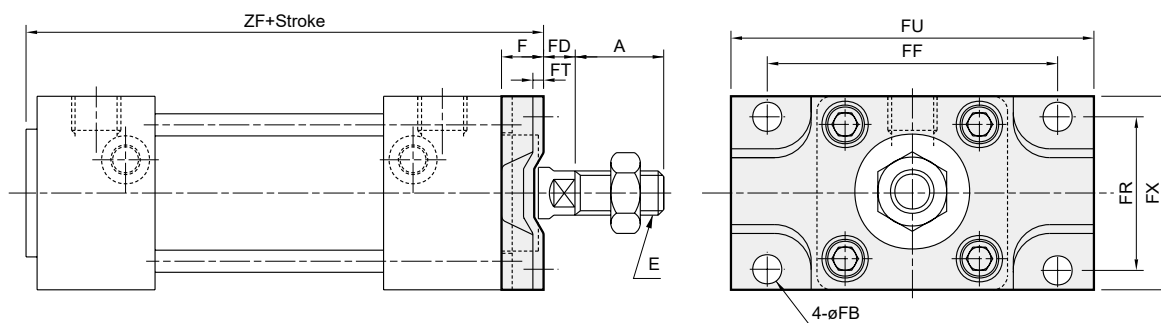

Code Tube I.D.	A	E	F	FB	FD	FF	FR	FT	FU	FX	ZF
40	30	M14×1.5	12	9	9	80	42	3.2	100	58	99
50	35	M18×1.5	12	9	11	90	50	3.2	110	66	105
63	35	M18×1.5	15	11.5	8	105	59	4.5	130	80	116

FB

Note. This type is applied to the cylinder which the stroke is within 500mm.
If the stroke is over 500mm, we advise to choose the **FBC** type.

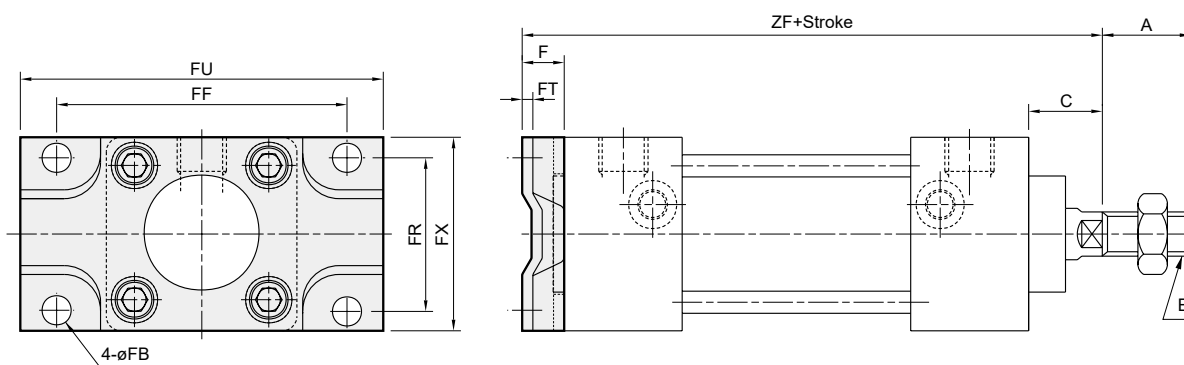

Code Tube I.D.	A	E	C	F	FB	FF	FR	FT	FU	FX	ZF
40	30	M14×1.5	21	12	9	80	42	3.2	100	58	117
50	35	M18×1.5	23	12	9	90	50	3.2	110	66	125
63	35	M18×1.5	23	15	11.5	105	59	4.5	130	80	136

FAC

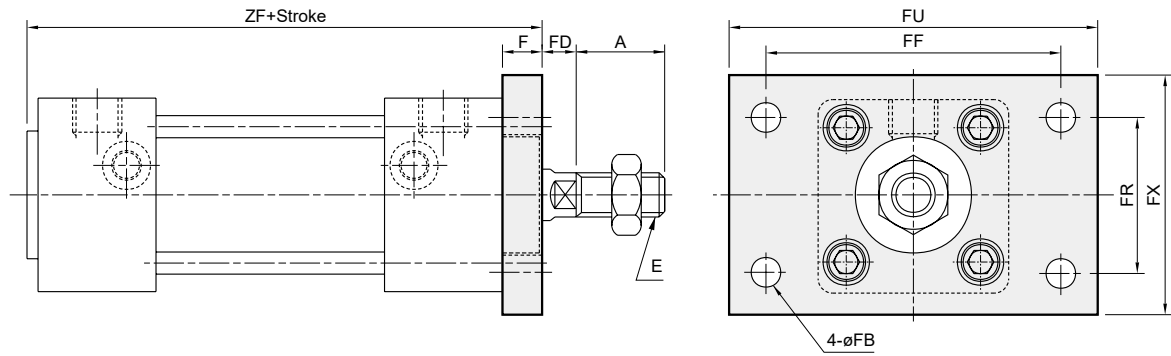

Code Tube I.D.	A	E	F	FB	FD	FF	FR	FU	FX	ZF
40	30	M14×1.5	12	9	9	80	42	100	65	99
50	35	M18×1.5	12	9	11	90	50	110	73	105
63	35	M18×1.5	15	11.5	8	105	59	130	84	116
80	40	M22×1.5	18	14	13	130	76	160	108	138
100	40	M26×1.5	18	14	14	150	92	180	124	149

FBC

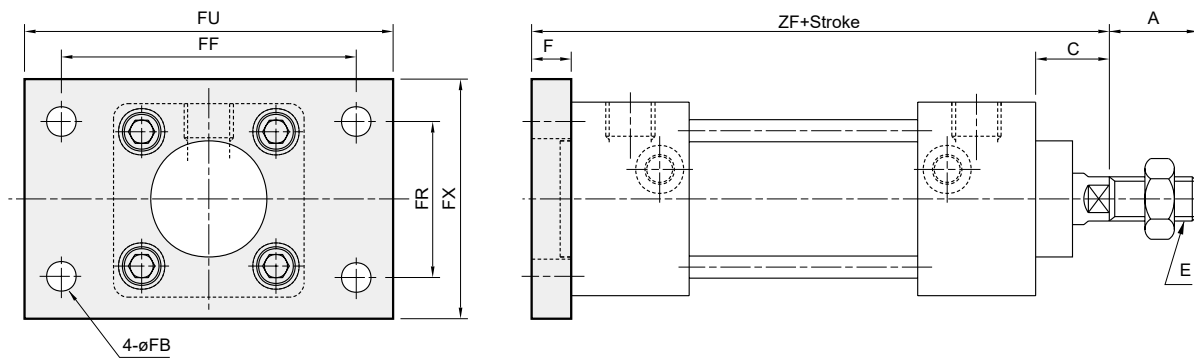

Code Tube I.D.	A	C	E	F	FB	FF	FR	FU	FX	ZF
40	30	21	M14×1.5	12	9	80	42	100	65	117
50	35	23	M18×1.5	12	9	90	50	110	73	125
63	35	23	M18×1.5	15	11.5	105	59	130	84	136
80	40	31	M22×1.5	18	14	130	76	160	108	165
100	40	32	M26×1.5	18	14	150	92	180	124	176

CA

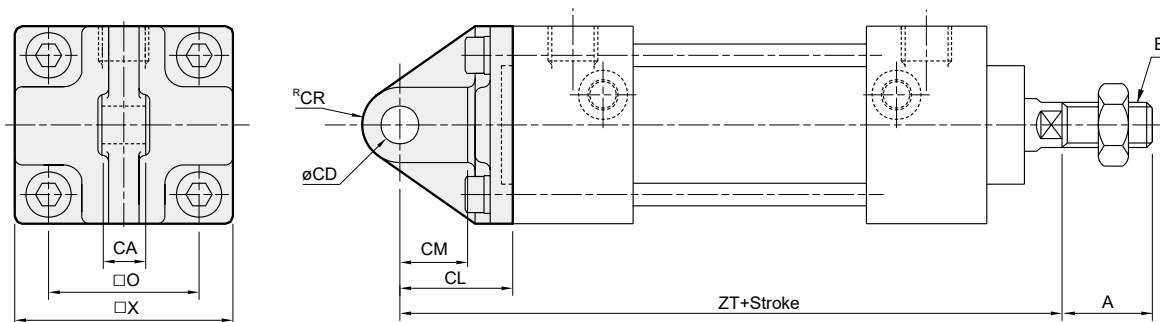

Code Tube I.D.	A	CA	CD	CL	CM	CR	E	O	X	ZT
40	30	15 ^{-0.1 -0.3}	10 ^{H10}	30	18	10	M14×1.5	40.5	58	135
50	35	18 ^{-0.1 -0.3}	12 ^{H10}	35	22	12	M18×1.5	48	66	148
63	35	25 ^{-0.1 -0.3}	16 ^{H10}	40	27	16	M18×1.5	59	80	161
80	40	31.5 ^{-0.1 -0.3}	20 ^{H10}	48	30	20	M22×1.5	74	100	195
100	40	35.5 ^{-0.1 -0.3}	25 ^{H10}	58	38	25	M26×1.5	90	118	216

CB

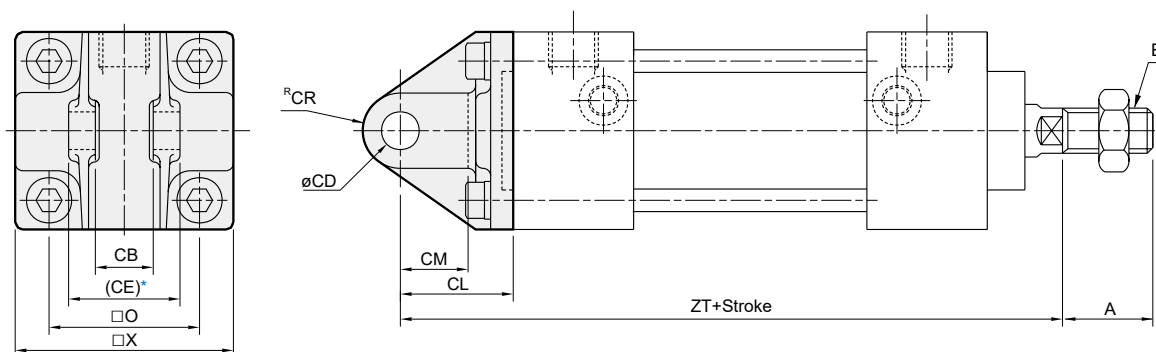

* Please do not take the sand casting plate as the mounting plate, because we do not machine it. If you have this special demand, please contact our sales representative.

Code Tube I.D.	A	CB	CD	CE	CL	CM	CR	E	O	X	ZT
40	30	15 ^{+0.3 +0.1}	10 ^{H10}	29.5	30	18	10	M14×1.5	40.5	58	135
50	35	18 ^{+0.3 +0.1}	12 ^{H10}	38	35	22	12	M18×1.5	48	66	148
63	35	25 ^{+0.3 +0.1}	16 ^{H10}	49	40	27	16	M18×1.5	59	80	161
80	40	31.5 ^{+0.3 +0.1}	20 ^{H10}	59	48	30	20	M22×1.5	74	100	195
100	40	35.5 ^{+0.3 +0.1}	25 ^{H10}	64	58	38	25	M26×1.5	90	118	216

TC

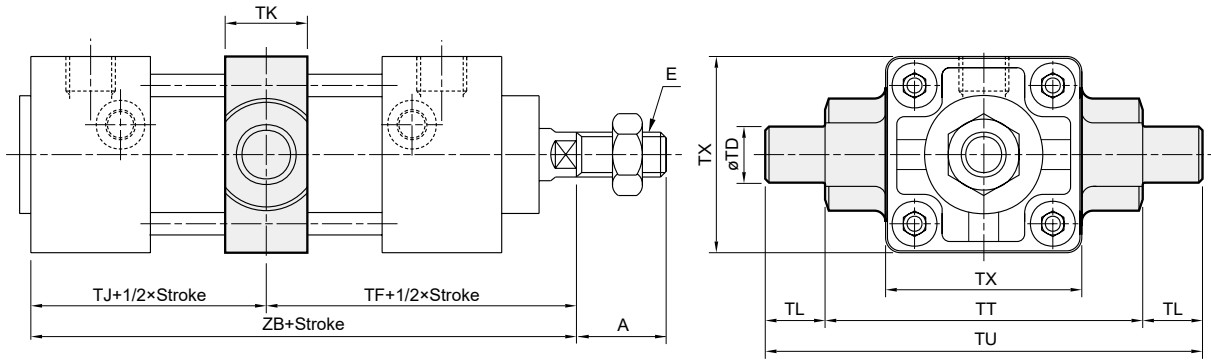

Code Tube I.D.	A	E	TD	TF	TJ	TK	TL	TT	TU	TX	ZB
40	30	M14×1.5	15 ^{es}	63	42	22	16	85	117	58	105
50	35	M18×1.5	15 ^{es}	68	45	22	16	95	127	67	113
63	35	M18×1.5	18 ^{es}	72	49	28	19	110	148	82	121
80	40	M22×1.5	25 ^{es}	89	58	34	26	140	192	102	147
100	40	M26×1.5	25 ^{es}	95	63	40	26	162	214	122	158

TA

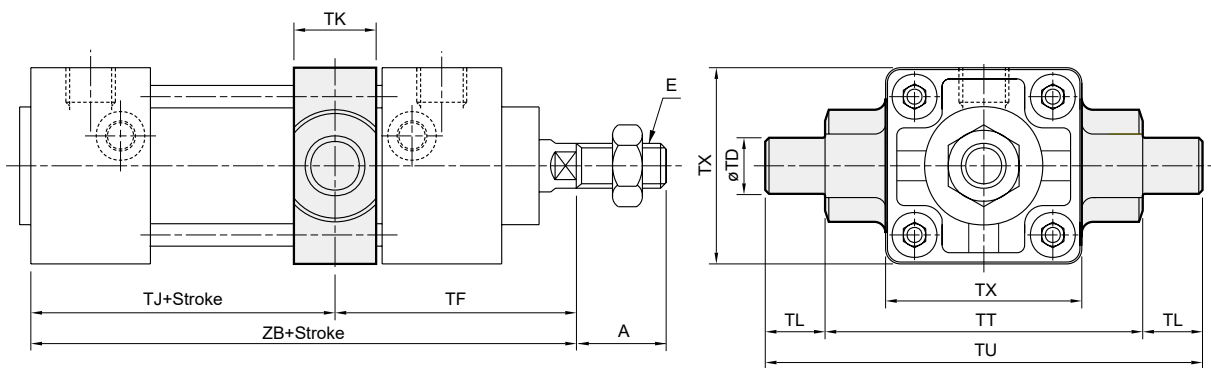

Code Tube I.D.	A	E	TD	TF	Without magnet		Magnet		TK	TL	TT	TU	TX
					TJ	ZB	TJ	ZB					
40	30	M14×1.5	15 ^{es}	60	45	105	75	135	22	16	85	117	58
50	35	M18×1.5	15 ^{es}	64	49	113	79	143	22	16	95	127	67
63	35	M18×1.5	18 ^{es}	69	52	121	82	151	28	19	110	148	82
80	40	M22×1.5	25 ^{es}	85	62	147	102	187	34	26	140	192	102
100	40	M26×1.5	25 ^{es}	92	66	158	106	198	40	26	162	214	122

TB

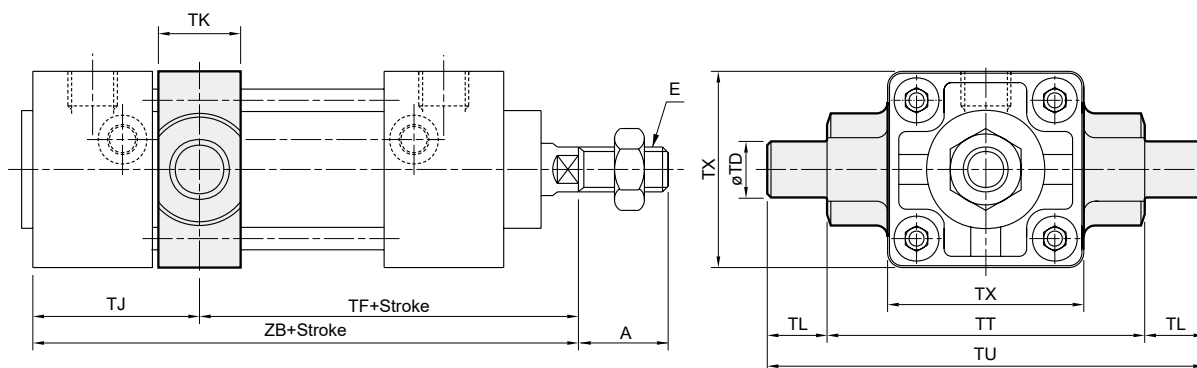

Code Tube I.D.	A	E	TD	Without magnet		Magnet		TJ	TK	TL	TT	TU	TX
				TF	ZB	TF	ZB						
40	30	M14×1.5	15 ^{øB}	66	105	96	135	39	22	16	85	117	58
50	35	M18×1.5	15 ^{øB}	72	113	102	143	41	22	16	95	127	67
63	35	M18×1.5	18 ^{øB}	75	121	105	151	46	28	19	110	148	82
80	40	M22×1.5	25 ^{øB}	93	147	133	187	54	34	26	140	192	102
100	40	M26×1.5	25 ^{øB}	98	158	138	198	60	40	26	162	214	122

SDS

Stroke over 1000mm

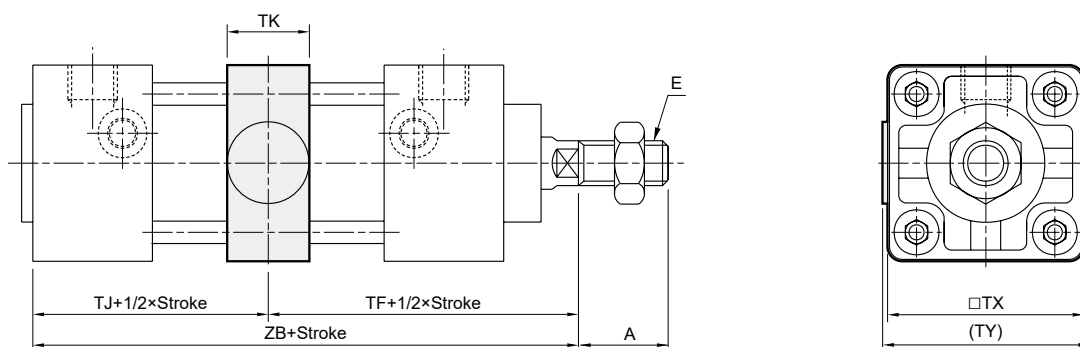

Code Tube I.D.	A	E	TF	TJ	TK	TX	TY	ZB
40	30	M14×1.5	63	42	22	58	60	105
50	35	M18×1.5	68	45	22	67	69	113
63	35	M18×1.5	72	49	28	82	84	121
80	40	M22×1.5	89	58	34	102	110	147
100	40	M26×1.5	95	63	40	122	132	158

STANDARD CYLINDER

11

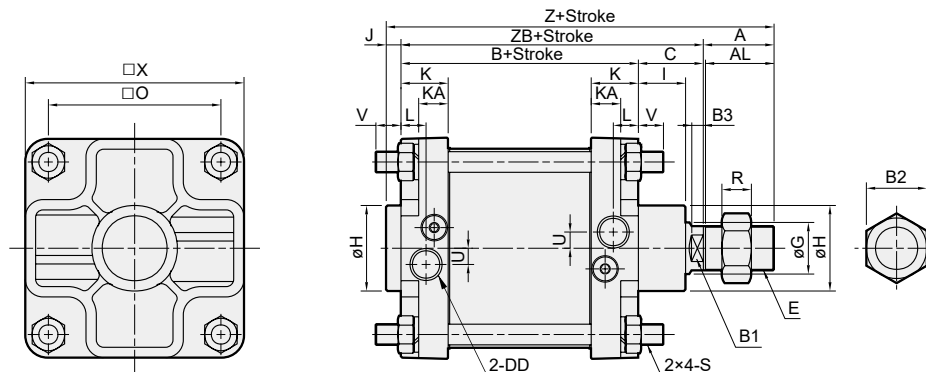

Code Tube I.D.	A	AL	B	B1	B2	B3	C	DD	E	G	H	I	J	K	KA	L	O	R	S	U	V	X	Z	ZB
125	45	42	136	30	41	9.5	47	Rc1/2	M30×1.5	35	58	32	10	32	20	17	117	15	M14×1.5	11	20	150	238	183
150	50	47	153	36	41	10	47	Rc1/2	M30×1.5	40	60	32	8	40.5	25	24.5	134	15	M16×1.5	12	26	175	258	200
200	63	60	154	46	70	20	67	Rc3/4	M45×1.5	50	74	35	8	42	25	24	182	27	M20×1.5	12	18	226	292	221

21

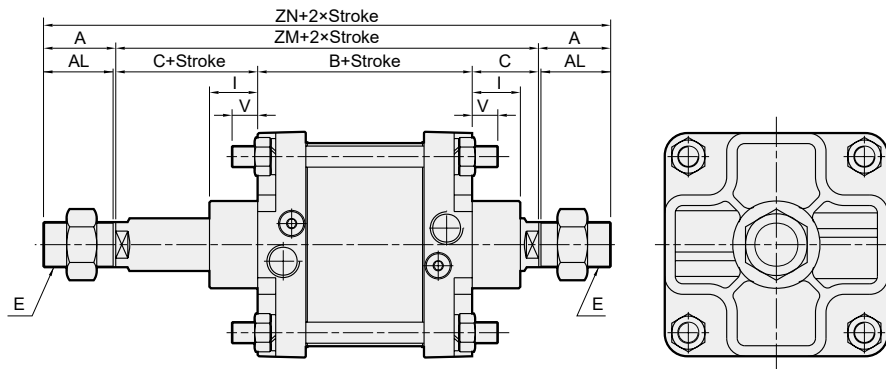

Code Tube I.D.	A	AL	B	C	E	I	V	ZM	ZN
125	45	42	136	47	M30×1.5	32	20	230	320
150	50	47	153	47	M30×1.5	32	26	247	347
200	63	60	154	67	M45×1.5	35	18	288	414

27

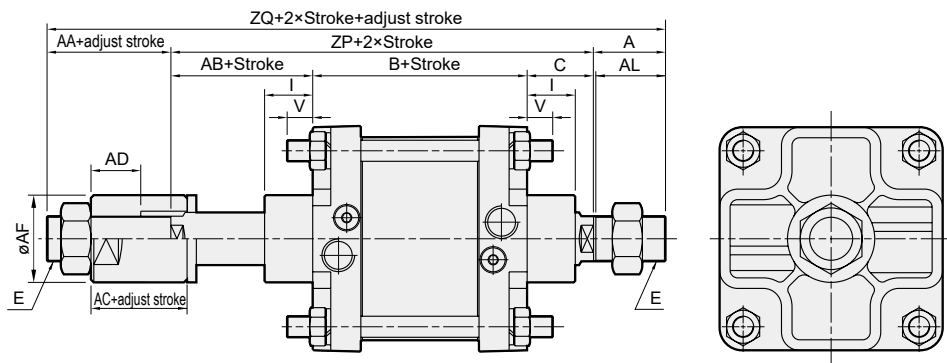

Code Tube I.D.	A	AA	AB	AC	AD	AF	AL	B	C	E	I	V	ZM	ZN	ZP	ZQ
125	45	38	47	30	18	60	42	136	47	M30×1.5	32	20	230	320	230	313
150	50	38	47	30	18	60	47	153	47	M30×1.5	32	26	247	347	247	335
200	63	38	50	30	18	70	60	154	67	M45×1.5	35	18	288	414	271	372

LB

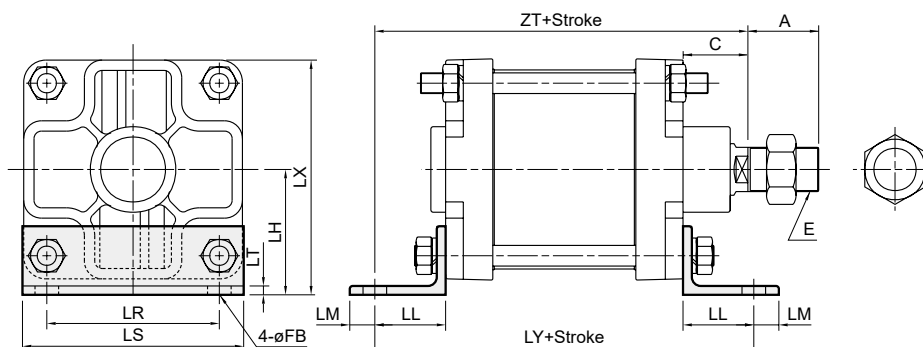

Code Tube I.D.	A	E	FB	LH	LL	LM	LR	LS	LT	LX	LY	ZT
125	45	M30×1.5	16	85	48	17	117	150	6	162	232	231
150	50	M30×1.5	18	96.5	55	20	134	175	9	184	263	255
200	63	M45×1.5	24	132	60	30	150	226	10	245	274	281

FAC

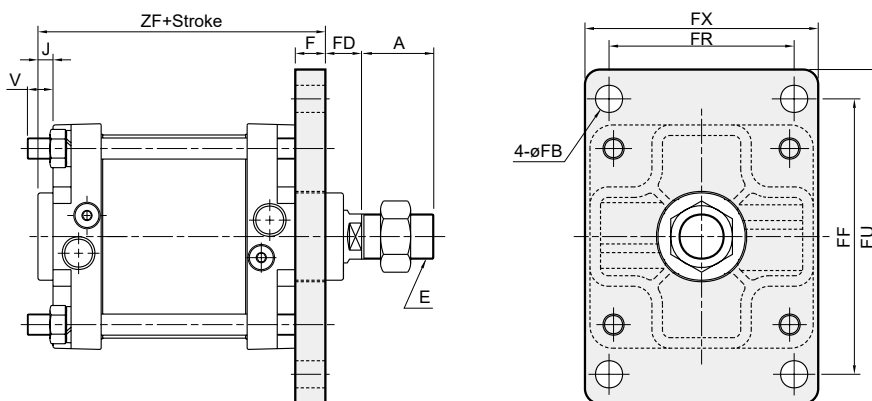

Code Tube I.D.	A	E	F	FB	FD	FF	FR	FU	FX	J	V	ZF
125	45	M30×1.5	20	18	27	183	123	222	155	10	20	166
150	50	M30×1.5	20	18	27	230	134	275	185	8	26	181
200	63	M45×1.5	25	24	42	280	150	335	225	8	11	187

FBC

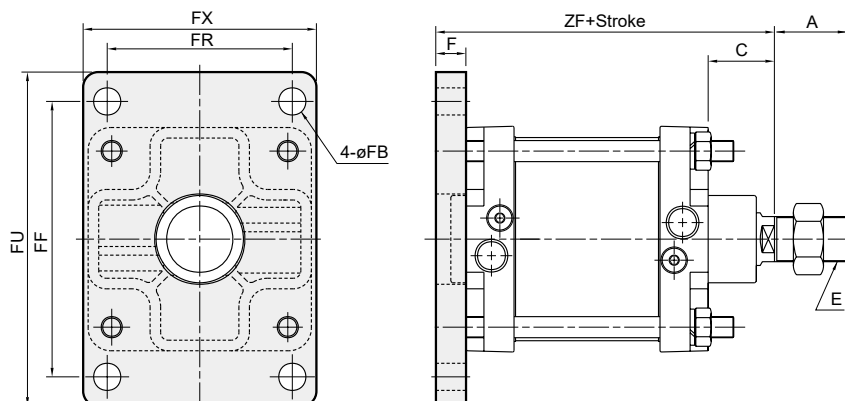

Code Tube I.D.	A	C	E	F	FB	FF	FR	FU	FX	ZF
125	45	47	M30×1.5	20	18	183	123	222	155	203
150	50	47	M30×1.5	20	18	230	134	275	185	220
200	63	67	M45×1.5	25	24	280	150	335	225	246

CA

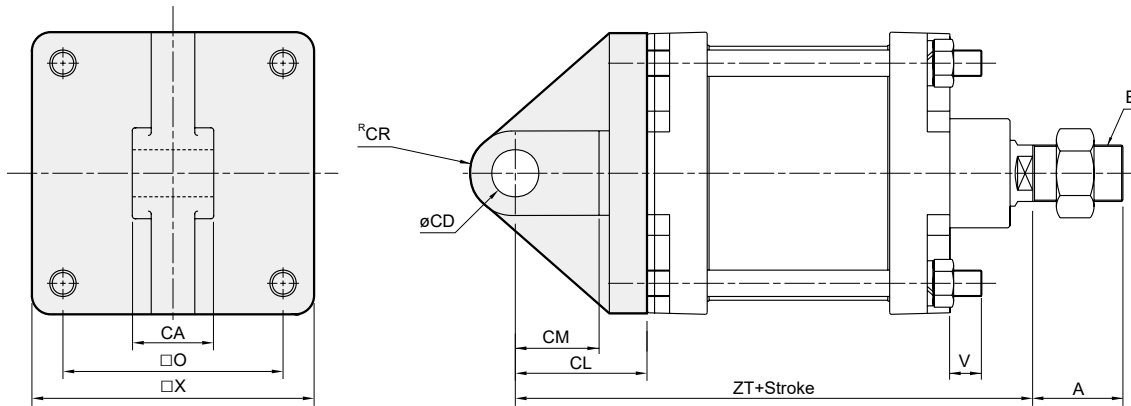

Code Tube I.D.	A	CA	CD	CL	CM	CR	E	O	X	ZT	V
125	45	43 ^{-0.1} _{-0.3}	25 ^{H10}	65	45	24	M30×1.5	117	150	248	20
150	50	40 ^{-0.1} _{-0.3}	30 ^{H10}	78	53	27.5	M30×1.5	134	175	278	26
200	63	50 ^{-0.1} _{-0.3}	40 ^{H10}	85	55	40	M45×1.5	182	226	306	12

CB

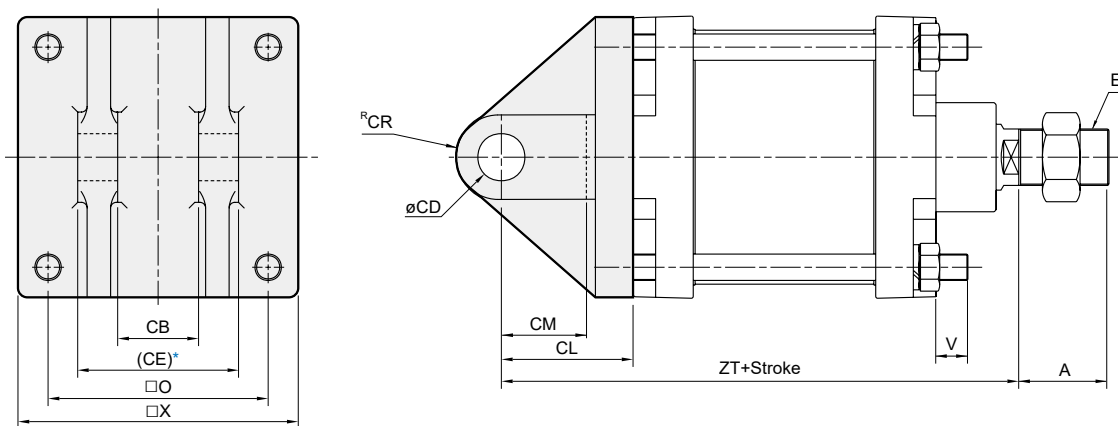

* Please do not take the sand casting plate as the mounting plate, because we do not machine it. If you have this special demand, please contact our sales representative.

Code Tube I.D.	A	CB	CD	CE	CL	CM	CR	E	O	X	ZT	V
125	45	43 ^{+0.3} _{+0.1}	25 ^{H10}	83	70	48	24	M30×1.5	117	150	253	20
150	50	40 ^{+0.3} _{+0.1}	30 ^{H10}	90	78	53	27.5	M30×1.5	134	175	278	26
200	63	50 ^{+0.3} _{+0.1}	40 ^{H10}	100	85	55	40	M45×1.5	182	226	306	12

TC

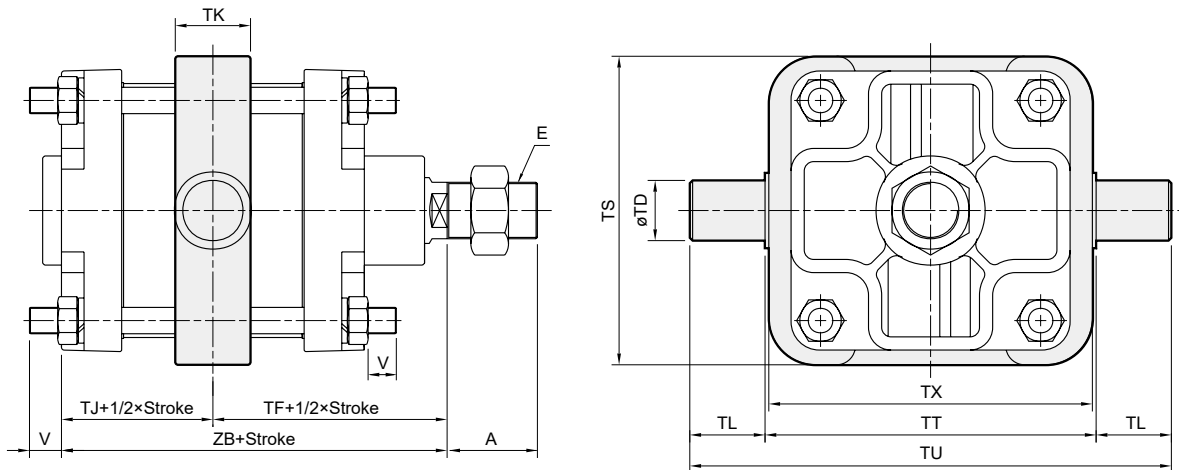

Code Tube I.D.	A	E	TD	TF	TJ	TK	TL	TS	TT	TU	TX	V	ZB
125	45	M30×1.5	32 ^{øB}	115	68	40	40	164	176	256	172	17	183
150	50	M30×1.5	35 ^{øB}	123.5	76.5	41	40	194	200	280	198	16	200
200	63	M45×1.5	45 ^{øB}	144	77	59	45	255	265	355	255	8.5	221

TA

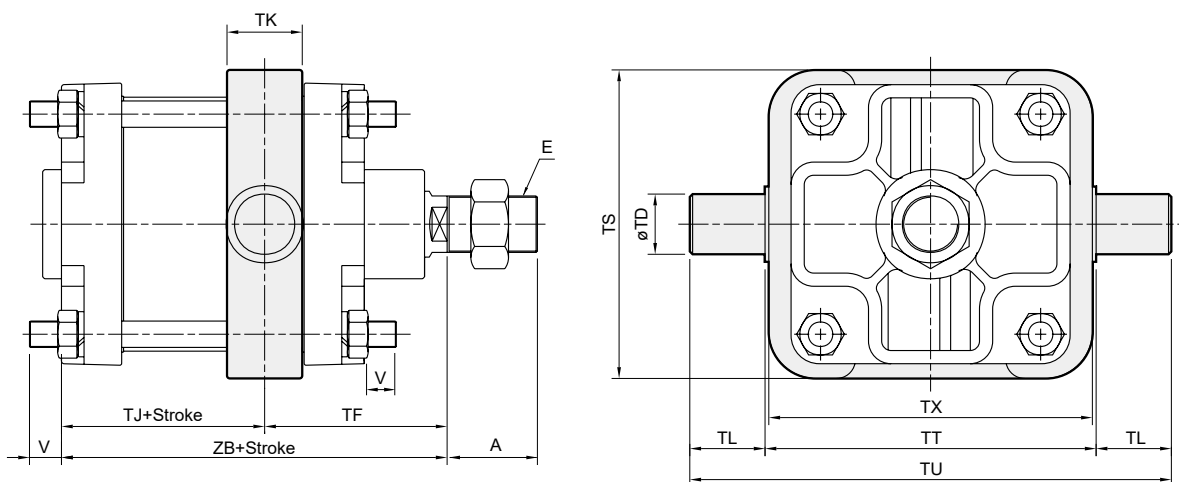

Code Tube I.D.	A	E	TD	TF	Without magnet		Magnet		TK	TL	TS	TT	TU	TX	V
					TJ	ZB	TJ	ZB							
125	45	M30×1.5	32 ^{øB}	100	83	183	129	229	40	40	164	176	256	172	17
150	50	M30×1.5	35 ^{øB}	109	91	200	137	246	41	40	194	200	280	198	16
200	63	M45×1.5	45 ^{øB}	139.5	81.5	221	125.5	265	59	45	255	265	355	255	8.5

TB

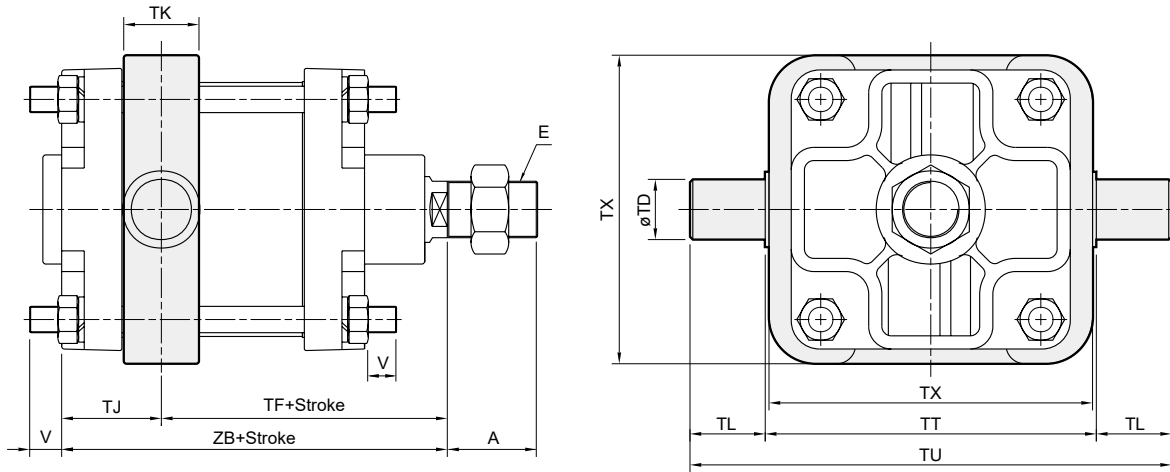

Code Tube I.D.	A	E	TD	Without magnet		Magnet		TJ	TK	TL	TS	TT	TU	TX	V
				TF	ZB	TF	ZB								
125	45	M30×1.5	32 ^{SB}	130	183	176	229	53	40	40	164	176	256	172	17
150	50	M30×1.5	35 ^{SB}	138	200	184	246	62	41	40	194	200	280	198	16
200	63	M45×1.5	45 ^{SB}	148.5	221	192.5	265	72.5	59	45	255	265	355	255	8.5

SDS

Stroke over 1000mm

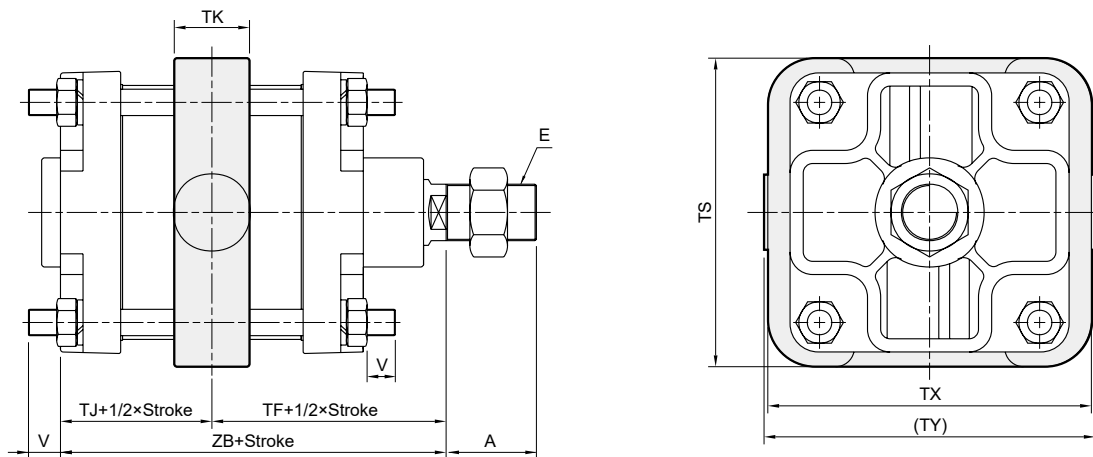

Code Tube I.D.	A	E	TF	TJ	TK	TS	TX	TY	V	ZB
125	45	M30×1.5	115	68	40	164	172	174	17	183
150	50	M30×1.5	123.5	76.5	41	194	198	200	16	200
200	63	M45×1.5	144	77	59	255	255	263	8.5	221

STANDARD CYLINDER

Y connector

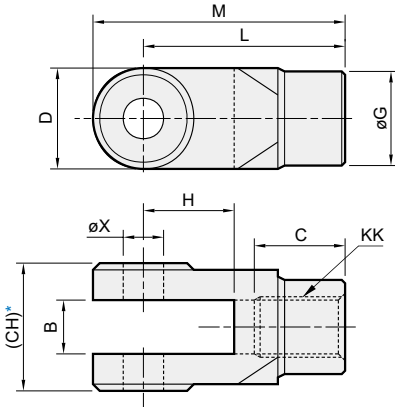

I connector

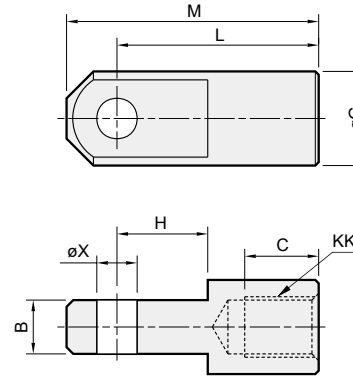

* Please do not take the sand casting plate as the mounting plate, because we do not machine it. If you have this special demand, please contact our sales representative.

Code Tube I.D.	B		C		CH		D		G		H		KK		L		M		X ^{H10}
	Y	I	Y	I	Y	I	Y	I	Y	I	Y	I	Y	I	Y	I	Y	I	
40	16 ^{+0.3} / _{+0.1}	16 ^{-0.1} / _{-0.3}	25	20	38	—	26	—	ø24	ø24	25	25	M14×1.5	55	55	68	68	ø12 ^{+0.07} / ₀	
50	16 ^{+0.3} / _{+0.1}	16 ^{-0.1} / _{-0.3}	27	22	38	—	30	—	ø28	ø28	27	27	M18×1.5	60	60	75	75	ø12 ^{+0.07} / ₀	
63			32	27	38	—	30	—	ø28	ø28	27	27	M18×1.5	60	60	75	75	ø12 ^{+0.07} / ₀	
80	28 ^{+0.3} / _{+0.1}	28 ^{-0.1} / _{-0.3}	32	27	55	—	38	—	ø36	ø36	32	32	M22×1.5	71	71	90	90	ø18 ^{+0.07} / ₀	
100	30 ^{+0.3} / _{+0.1}	30 ^{-0.1} / _{-0.3}	35	30	59	—	42	—	ø40	ø40	38	38	M26×1.5	83	83	104	104	ø20 ^{+0.08} / ₀	
125	32 ^{+0.3} / _{+0.1}	32 ^{-0.1} / _{-0.3}	35	40	76	—	58	—	ø45	ø50	38	32	M30×1.5	80	80	109	109	ø20 ^{+0.08} / ₀	
150	40 ^{+0.3} / _{+0.1}	40 ^{-0.1} / _{-0.3}	35	40	84	—	54	—	ø45	ø60	39	32	M30×1.5	80	80	107	107	ø25 ^{+0.08} / ₀	
200	50 ^{+0.3} / _{+0.1}	50 ^{-0.1} / _{-0.3}	67	67	100	—	85	—	ø70	ø70	54	44	M45×1.5	125	125	167.5	167.5	ø40 ^{+0.1} / ₀	

PIN

P

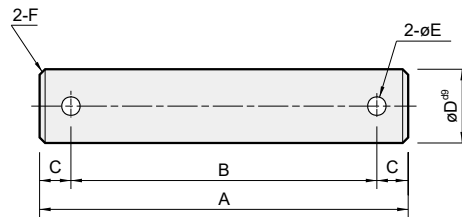

for Y & I connector

Code Tube I.D.	A	B	C	D ^{d9}	E	F	Split pin
40	57	46	5.5	ø12 ^{-0.05} / _{-0.09}	3.5	1.0	3.2×20L
50	57	46	5.5	ø12 ^{-0.05} / _{-0.09}	3.5	1.0	3.2×20L
63	57	46	5.5	ø12 ^{-0.05} / _{-0.09}	3.5	1.0	3.2×20L
80	78	64	7	ø18 ^{-0.05} / _{-0.09}	4	1.2	4×25L
100	87	70	8.5	ø20 ^{-0.06} / _{-0.12}	5	1.5	5×35L
125	100	83	8.5	ø20 ^{-0.06} / _{-0.12}	5	1.5	5×35L
150	112	95	8.5	ø25 ^{-0.06} / _{-0.12}	5	2.0	5×35L
200	115	105	5	ø40 ^{-0.08} / _{-0.14}	5	2.0	5×55L

for CA & CB

Code Tube I.D.	A	B	C	D ^{d9}	E	F	Split pin
40	48	37	5.5	ø10 ^{-0.05} / _{-0.09}	3.5	1.0	3.2×20L
50	57	46	5.5	ø12 ^{-0.05} / _{-0.09}	3.5	1.0	3.2×20L
63	72	58	7	ø16 ^{-0.05} / _{-0.09}	4	1.2	4×25L
80	87	70	8.5	ø20 ^{-0.06} / _{-0.12}	5	1.5	5×35L
100	93	76	8.5	ø25 ^{-0.06} / _{-0.12}	5	1.5	5×35L
125	112	95	8.5	ø25 ^{-0.06} / _{-0.12}	5	1.5	5×35L
150	119	102	8.5	ø30 ^{-0.06} / _{-0.12}	5	2.0	5×40L
200	115	105	5	ø40 ^{-0.08} / _{-0.14}	5	2.0	5×55L

Order example

MCQA — As standard order example — VR — 4E2C — AC110 — L

MODEL

SOLENOID VALVE
LINK SEATS
VR
VH

4 way (5 port)

E1: Single solenoid
E2: Double solenoid

C: Closed center
P: Pressure center
R: Exhaust center
(Only for 4E2)

VOLTAGE
AC220V(50/60)Hz
AC110V(50/60)Hz
DC24V

ELECTRIC CONNECTION

Standard	
Blank	DIN terminal
L	DIN terminal with LED indicator
E	Explosion protection
Power saving (for DC24V)	
KL	DIN terminal with LED indicator

*1. MCQA- $\varnothing 40 \sim \varnothing 63$ (for MVSC-260 valve)

*2. MCQA- $\varnothing 80, \varnothing 100$ (for MVSC-300 valve)

VR

VH

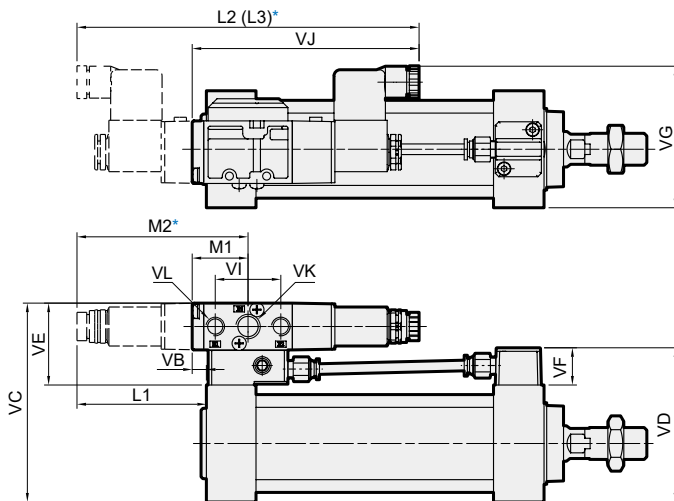
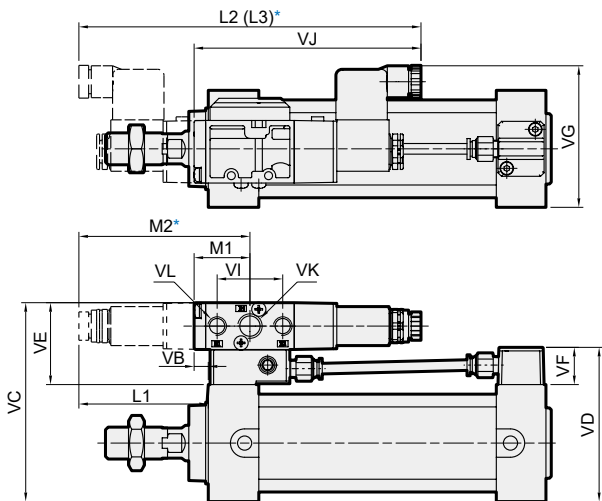

Code Tube I.D.	L1	L2	L3	M1	M2	VB	VC	VD	VE	VF	VG	VI	VJ	VK	VL	Valve type
40	77.5	199	220	31.5	99.5	9.5	104.2	79	46.2	21	76	37	131	Rc1/4	Rc1/8	MVSC-260
50	78.5	199	220	31.5	99.5	8.5	112.2	87	46.2	21	80	37	131	Rc1/4	Rc1/8	MVSC-260
63	79.5	199	220	31.5	99.5	7.5	126.2	101	46.2	21	87	37	131	Rc1/4	Rc1/8	MVSC-260
80	80.5	222	275	45	111	14.5	159	128	59	28	90	52	156	Rc3/8	Rc3/8	MVSC-300
100	78.5	222	275	45	111	12.5	179	146	59	28	104	52	156	Rc3/8	Rc3/8	MVSC-300

* L2 for 4E2 size, L3 for 4E2C.P.R size, M2 for 4E2 and 4E2C.P.R size.



Technical data



Caution for safety
(Read before installing)



Order example

MCQA — 50 — 100 — AH

MODEL

TUBE I.D.

LENGTH

TYPE

Schematic

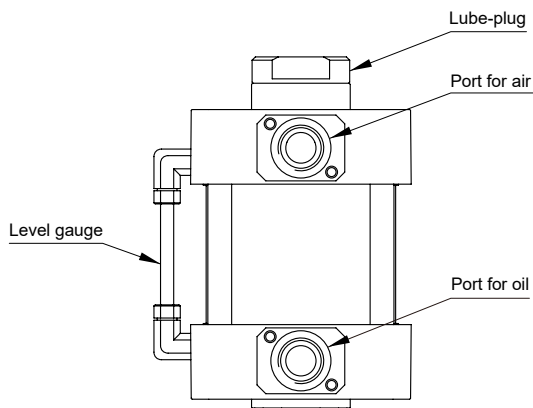

Volume calculation

$$V = \frac{\pi D^2}{4} \times L \times 10^{-6}$$

V: Air/oil converter volume (L)

D: Tube I.D. (mm)

L: Length of converter (mm)



Features

- Cylinder thrust should be 70% (50% of Maximum Speed) of theoretical force.
- Displacement should be approximately 50% of total volume.
- Maximum acceleration is approximately 200mm/sec.
- ISO VG32 or an equivalent oil is recommended.
- Oil feed should not exceed 80% of total volume.
- Unit should be installed vertically above the cylinder / actuator.

Specification

Model	MCQA-AH
Tube I.D. (mm)	40,50,63,80,100,125,150
Medium	ISO VG32 Equivalent
Operating pressure range	0.05~1 MPa
Proof pressure	1.5 MPa
Ambient temperature	-5~+60°C (No freezing)

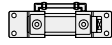
Order example of mounting accessories

Code	LB (Purchase 2 pcs)	FAC	FBC
Mounting Tube I.D.			
ø40	LB-Q1-40	FAC-Q1-40	
ø50	LB-Q1-50	FAC-Q1-50	
ø63	LB-Q1-63	FAC-Q1-63	
ø80	LB-Q1-80	FAC-Q1-80	
ø100	LB-Q1-100	FAC-Q1-100	
ø125	LB-Q1-125	FAC-Q1-125	
ø150	LB-Q1-150	FAC-Q1-150	

△ ø125, ø150: Factory assembled and shipped (self-assembled is not recommended)

Lubricating procedure

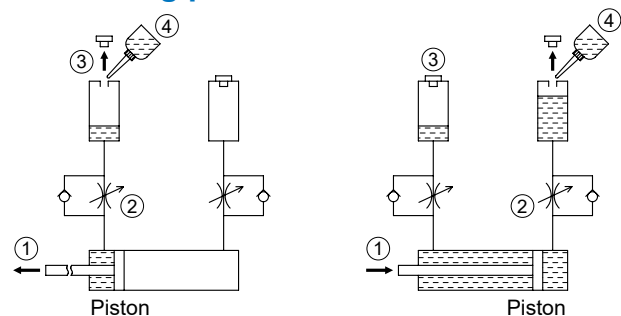

- ① Pull the piston to the oil supply side.
- ② Adjust the throttle valve to full-opened.
- ③ Unscrew the lube plug on the top center of the converter.
- ④ Fill the oil to the proper level and screw up the lube plug to seal the oil hole.
- ⑤ Push the piston to another end with a pressure of approximately 0.2 MPa.
- ⑥ Repeat step ② ~ ④.
- ⑦ After completion of filling oil, have the piston reciprocate 2~3 times with a pressure of approximately 0.2 MPa.

MCQA-AH Dimensions $\phi 40 \sim \phi 100$

AIR / OIL CONVERTER – INSTALLED UPRIGHTLY

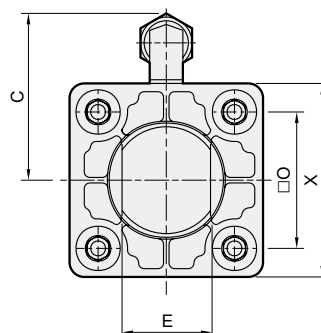
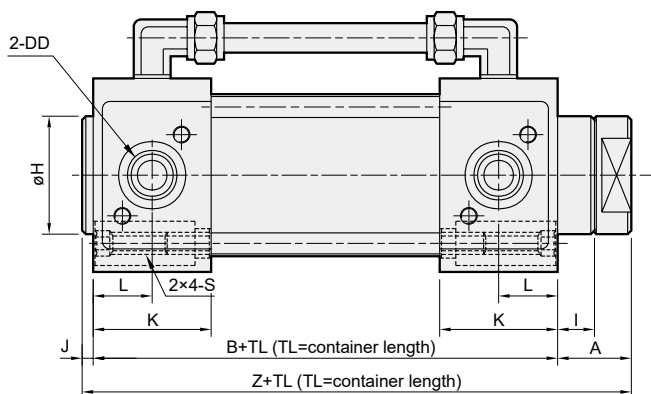

Mounting accessories

LB

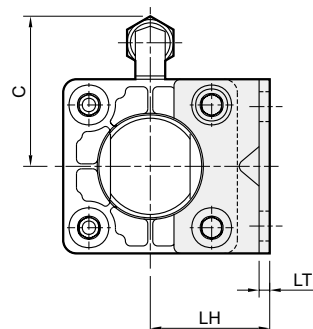
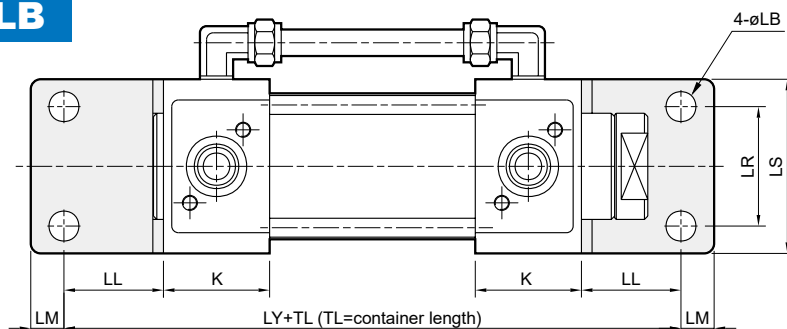

FAC FBC

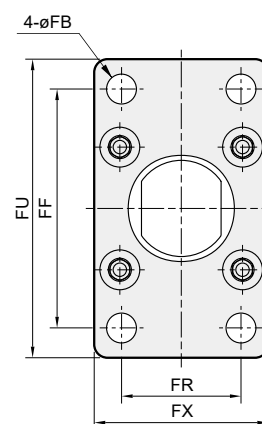
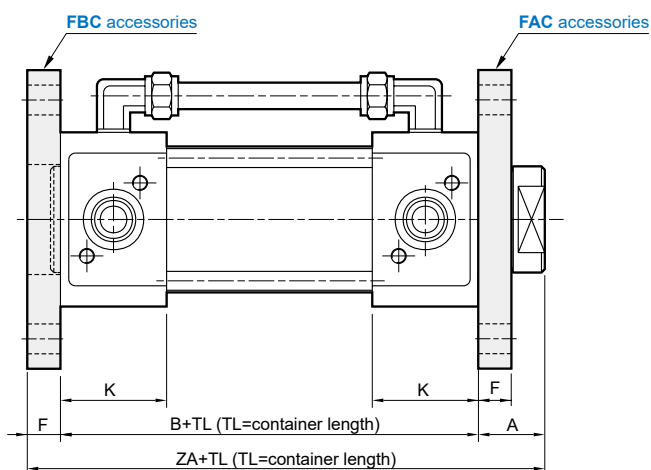

Code Tube I.D.	A	B	C	DD	E	F	FB	FF	FR	FU	FX	H	I	J	K	L	LB	LH	LL	LM	LR	LS	LT	LY	O	S	X	Z	ZA
40	21	62	49	Rc1/4	24	12	9	80	42	100	65	32	11	3	26	13	9	40	27	13	42	58	3.2	116	40.5	M8×1.25	58	86	95
50	21	66	53	Rc3/8	28	12	9	90	50	110	73	40	11	3	28	14	9	45	27	13	50	66	3.2	120	48	M8×1.25	66	90	99
63	21	72	66	Rc3/8	28	15	11.5	105	59	130	84	40	11	3	30	15	11.5	50	34	16	59	80	4.5	140	59	M8×1.25	80	96	108
80	27	82	70	Rc1/2	36	18	14	130	76	160	108	45	15	4	34	17	14	65	44	16	76	100	6.0	170	74	M12×1.75	100	113	127
100	27	90	79	Rc1/2	40	18	14	150	92	180	124	52	15	5	37	18.5	14	75	43	17	92	118	6.0	176	90	M12×1.75	118	122	135

MCQA-AH Dimensions $\phi 125, \phi 150$

AIR / OIL CONVERTER – INSTALLED UPRIGHTLY

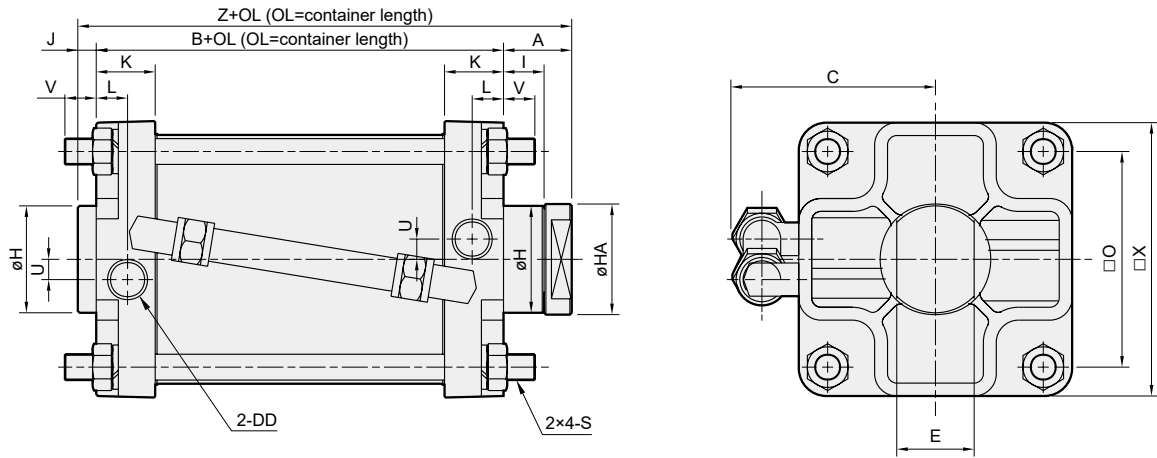

Mounting accessories

LB

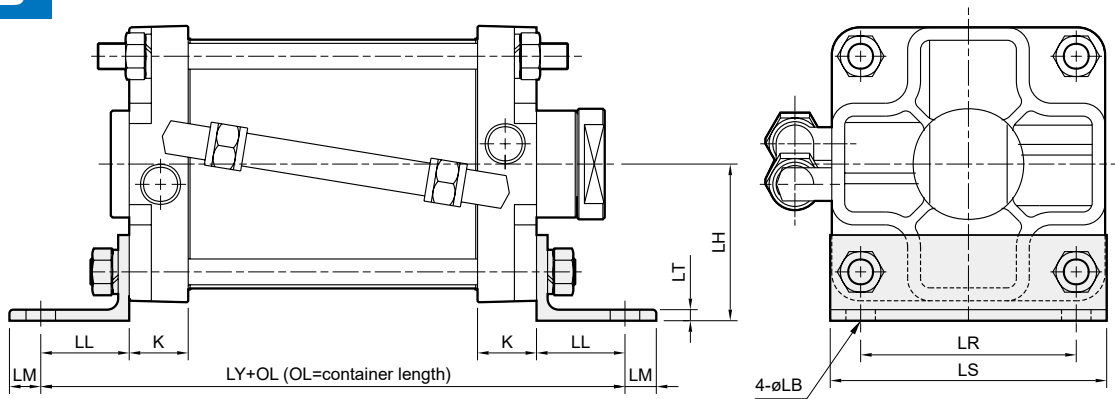

FAC

FBC

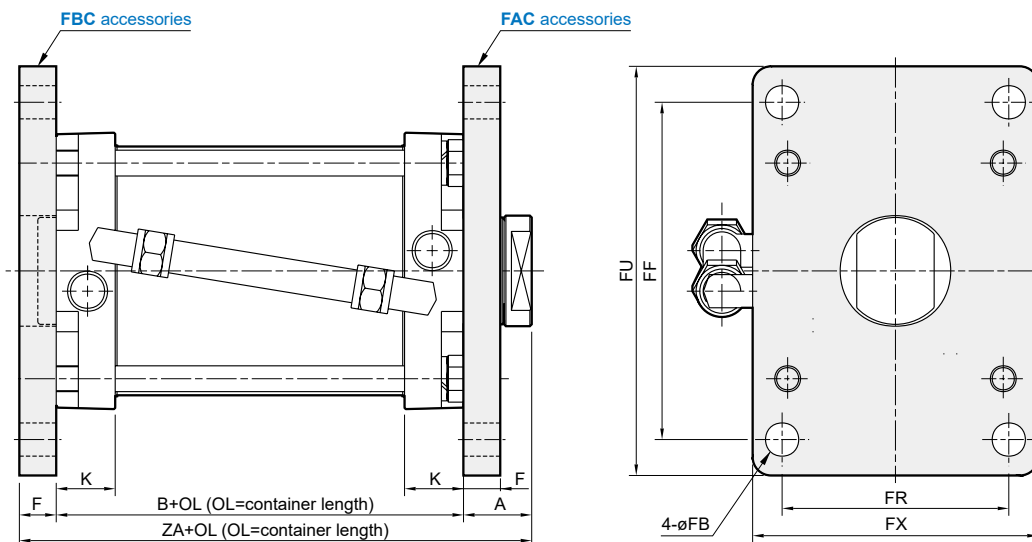

Code Tube I.D.	A	B	C	DD	E	F	FB	FF	FR	FU	FX	H	HA	I	J	K	L	LB	LH	LL	LM	LR	LS	LT	LY	O	S	U	V	X	Z	ZA
125	47	90	95	Rc1/2	42	20	18	183	123	222	155	58	60	32	10	32	17	16	85	48	17	115	151	6	186	117	M14x1.5	11	20	150	147	157
150	47	107	108	Rc1/2	42	20	18	230	134	275	185	60	60	32	8	40.5	24.5	18	96.5	55	20	134	175	9	217	134	M16x1.5	12	26	175	162	174



Special spec



Technical data



Caution for safety
(Read before installing)



Features

■ Non lubrication

Special housing and bushing enables self lubrication of piston rod.

■ High quality long service life

Hard anodised aluminium cylinder tubes offer a high resistance to corrosion and low internal friction.

■ Full range of NFPA interchangeable mounting configurations

Mounting dimensions are in accordance with ANSI (NFPA) T3.6.7 R2-1996, fluid power systems and products-square head industrial cylinders-mounting dimensions.

Table for standard stroke

Tube I.D	Stroke (inch)	Max. stroke (inch)
40: 1 1/2"	1, 2, 3, 4, 5, 6, 8, 10, 12, 14, 16, 18, 20	60
50: 2"	1, 2, 3, 4, 5, 6, 8, 10, 12, 14, 16, 18, 20, 24	60
63: 2 1/2"	1, 2, 3, 4, 5, 6, 8, 10, 12, 14, 16, 18, 20, 24	60
80: 3 1/4"	1, 2, 3, 4, 5, 6, 8, 10, 12, 14, 16, 18, 20, 24	60
100: 4"	1, 2, 3, 4, 5, 6, 8, 10, 12, 14, 16, 18, 20, 24	60

* Intermediate stroke are available, please contact us.

Specification

Model	MCQN				
Tube I.D. (inch)	1 1/2"	2"	2 1/2"	3 1/4"	4"
Port size	NPT3/8			NPT1/2	
Medium	Air				
Operating pressure range	0.05~1 MPa				
Proof pressure	1.5 MPa				
Ambient temperature	-5~+60°C (No freezing)				
Available speed range	50~500 mm/sec				
Sensor switch	RDC(V), RQC(V) , RCA				
Sensor switch holder	R*C(V)	DT7-1			DT7-2
	RCA	HV1	HV2	HV2	HV3 HV3

Order example

MCQN – 11 – 40 – 0425M

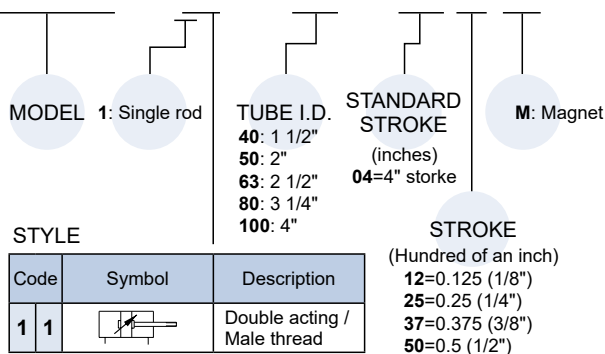

Accessories & Connector

Accessories \triangle TC accessories are factory assembled and shipped (self-assembled is not recommended)

Code	LB (LBx2)	CA	CB	CB2	FAC	FBC	TC \triangle
Mounting Tube I.D.							
$\phi 40$	LB-Q5-40x2	CA-Q5-40	CB-Q5-40	CB2-Q5-40	FAC-Q5-40	FBC-Q5-40	TC-Q5-40
$\phi 50$	LB-Q5-50x2	CA-Q5-50	CB-Q5-50	CB2-Q5-50	FAC-Q5-50	FBC-Q5-50	TC-Q5-50
$\phi 63$	LB-Q5-63x2	CA-Q5-63	CB-Q5-63	CB2-Q5-63	FAC-Q5-63	FBC-Q5-63	TC-Q5-63
$\phi 80$	LB-Q5-80x2	CA-Q5-80	CB-Q5-80	CB2-Q5-80	FAC-Q5-80	FBC-Q5-80	TC-Q5-80
$\phi 100$	LB-Q5-100x2	CA-Q5-100	CB-Q5-100	CB2-Q5-100	FAC-Q5-100	FBC-Q5-100	TC-Q5-100

Pin

Connector		Applicable CA/ CB/ CB2/ Y/ I	
Code	Y	I	PIN (with split pin)
Mounting Tube I.D.			Fig
$\phi 40$	Y-Q5-40	I-Q5-40	$\phi 40$
$\phi 50$			PIN-Q5-40-1-P
$\phi 63$			
$\phi 80$	Y-Q5-80	I-Q5-80	$\phi 80$
$\phi 100$			PIN-Q5-80-1-P

Order example of self-assembled

The tube I.D. $\phi 63$ of LB accessories, Y connector and pin.

No.	Order number	Qty
1	LB-Q5-63x2	1
2	Y-Q5-40	1
3	PIN-Q5-40-1-P	1

* To order accessories/
connectors/ pin separately,
please place orders separately
according to the order codes
in the above table.

Order example of factory assembled

\triangle Cylinders and accessories are distinguished by the symbol " + ".

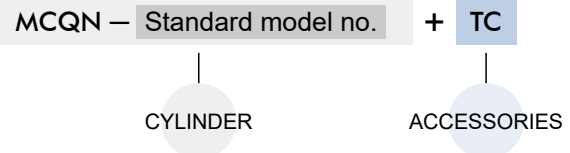

Installation of sensor switch

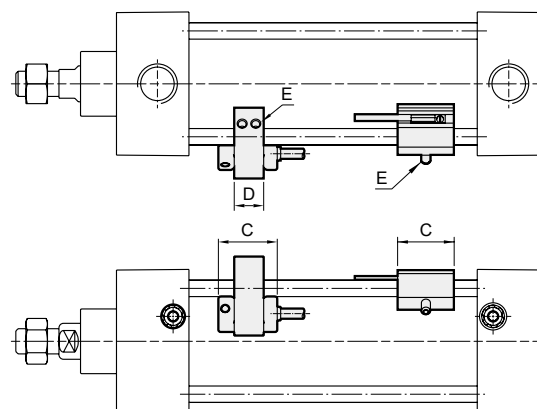
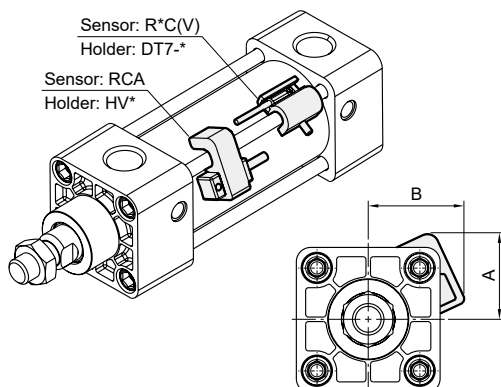

Unit: inch

Code Tube I.D.	Sensor switch	Holder	A	B	C	D	E
40	RCA	HV1	1.10	1.47	1.02	0.51	M4×10L
50	RCA	HV2	1.49	1.68	1.02	0.51	M4×10L
63	RCA	HV2	1.66	1.86	1.02	0.51	M4×10L
80	RCA	HV3	1.87	2.13	1.02	0.51	M4×10L
100	RCA	HV3	2.15	2.42	1.02	0.51	M4×10L

Code Tube I.D.	Sensor switch	Holder	A	B	C	E
40	R ⁺ C(V)	DT7-1	1.04	1.08	0.98	M4×12L
50	R ⁺ C(V)	DT7-1	1.24	1.26	0.98	M4×12L
63	R ⁺ C(V)	DT7-1	1.42	1.44	0.98	M4×12L
80	R ⁺ C(V)	DT7-2	1.75	1.79	0.98	M4×12L
100	R ⁺ C(V)	DT7-2	2	2.07	0.98	M4×12L

11

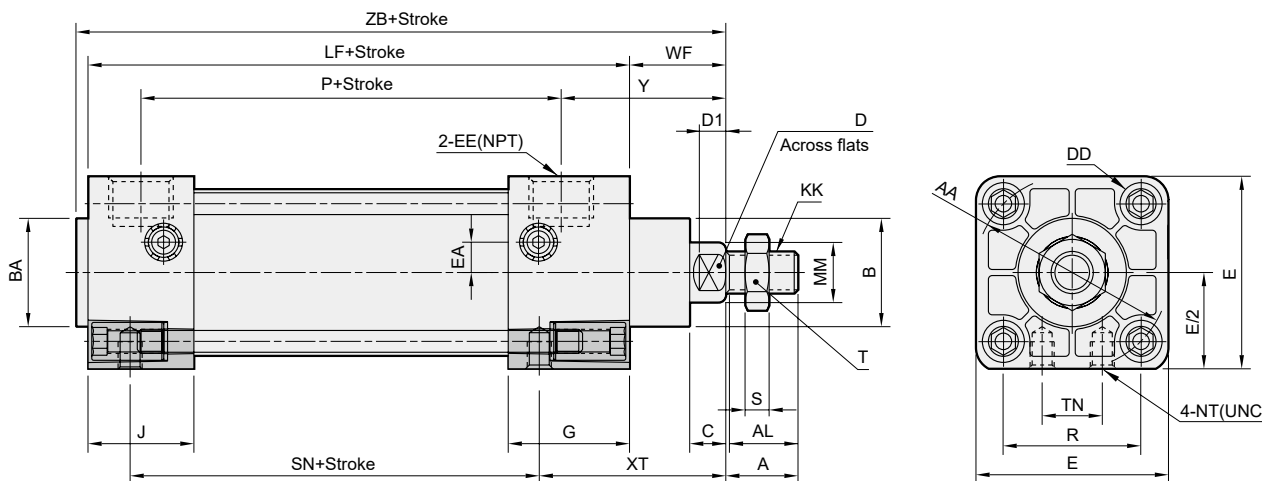

Unit: inch

Code Tube I.D.	A	AA	AL	B	BA	C	D	D1	DD	E	EA	EE	G	J	KK	LF	MM	NT	P	R
40	0.75	2.02	0.673	1.125	1.125	0.375	0.56	0.3	1/4-28	2	0.32	3/8	1.26	1.10	7/16-20	3.625	0.625	1/4-20×0.28 dp	2.36	1.43
50	0.75	2.60	0.673	1.125	1.125	0.375	0.56	0.3	5/16-24	2.5	0.43	3/8	1.26	1.06	7/16-20	3.625	0.625	5/16-18×0.44 dp	2.40	1.84
63	0.75	3.10	0.673	1.125	1.125	0.375	0.56	0.3	5/16-24	3	0.47	3/8	1.30	1.06	7/16-20	3.75	0.625	3/8-16×0.59 dp	2.48	2.19
80	1.125	3.90	1.045	1.5	1.5	0.5	0.88	0.4	3/8-24	3.75	—	1/2	1.57	1.18	3/4-16	4.25	1	1/2-13×0.63 dp	2.72	2.76
100	1.125	4.70	1.045	1.5	1.5	0.5	0.88	0.4	3/8-24	4.5	—	1/2	1.57	1.18	3/4-16	4.25	1	1/2-13×0.63 dp	2.72	3.32

Code Tube I.D.	S	SN	T	TN	WF	XT	Y	ZB
40	0.26	2.25	0.69	0.63	1	1.94	1.71	4.75
50	0.26	2.25	0.69	0.88	1	1.94	1.71	4.75
63	0.26	2.38	0.69	1.25	1	1.94	1.75	4.88
80	0.42	2.63	1.12	1.50	1.38	2.44	2.34	5.83
100	0.42	2.63	1.12	2.06	1.38	2.44	2.34	5.83

STANDARD CYLINDER

Cylinder weight

Unit: kg

Model	Basic weight MCQN-11	Basic weight (magnet) MCQN-11	Stroke 1 inch MCQN-11
Tube I.D.			
40	0.664	0.676	0.078
50	0.965	0.981	0.096
63	1.314	1.334	0.108
80	2.482	2.510	0.200
100	3.266	3.300	0.220

Accessories weight

Unit: kg

Model	LB	CA	CB	CB2	FAC/FBC	TC	Y	I	PIN
Tube I.D.									
40	0.160	0.285	0.229	0.287	0.246	0.554	0.205	0.150	0.065
50	0.240	0.394	0.377	0.424	0.403	0.644	0.205	0.150	0.065
63	0.300	0.531	0.521	0.563	0.576	0.840	0.205	0.150	0.065
80	0.633	1.511	1.302	1.482	1.408	1.098	0.662	0.522	0.175
100	0.955	2.047	1.821	2.033	2.015	1.450	0.662	0.522	0.175

LB

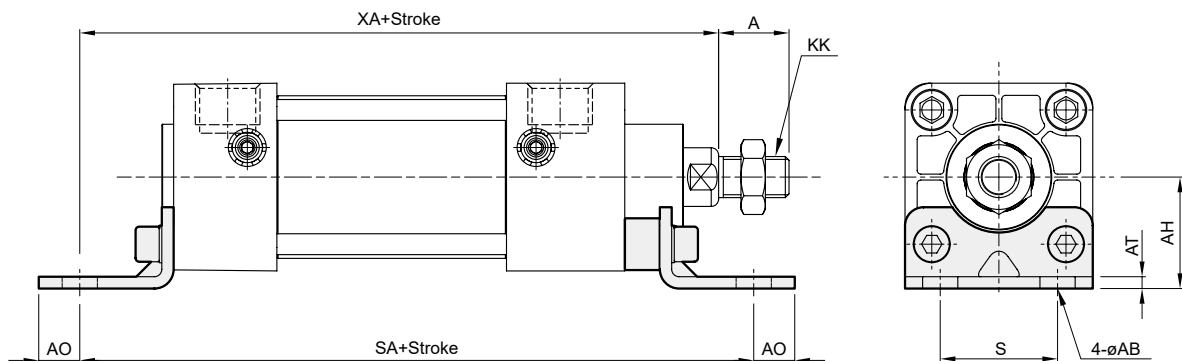

Unit: inch

Code Tube I.D.	A	AB	AH	AT	AO	KK	S	SA	XA
40	0.75	0.38	1.19	0.13	0.44	7/16-20	1.25	6	5.63
50	0.75	0.38	1.44	0.13	0.56	7/16-20	1.75	6	5.63
63	0.75	0.38	1.63	0.13	0.56	7/16-20	2.25	6.13	5.75
80	1.125	0.5	1.94	0.17	0.75	3/4-16	2.75	7.38	6.88
100	1.125	0.5	2.25	0.23	0.75	3/4-16	3.5	7.38	6.88

FAC

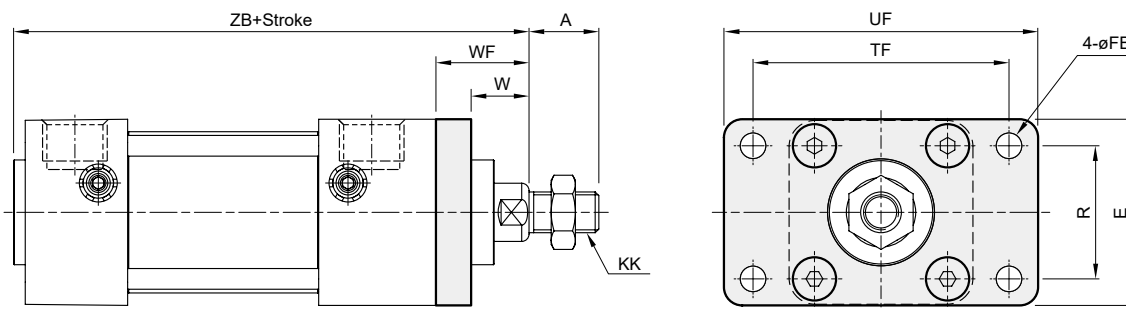

FBC

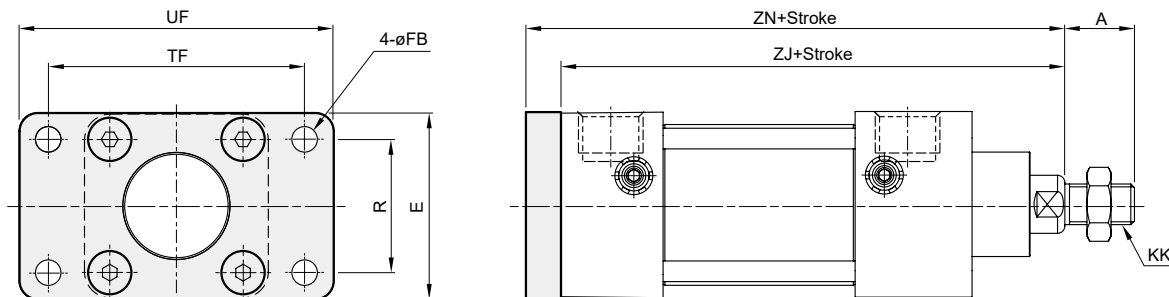

Unit: inch

Code Tube I.D.	A	E	FB	KK	R	TF	UF	W	WF	ZB	ZJ	ZN
40	0.75	2	0.25	7/16-20	1.43	2.75	3.38	0.63	1	4.75	4.63	5
50	0.75	2.5	0.31	7/16-20	1.84	3.38	4.13	0.63	1	4.75	4.63	5
63	0.75	3	0.31	7/16-20	2.19	3.88	4.63	0.63	1	4.88	4.75	5.13
80	1.125	3.75	0.38	3/4-16	2.76	4.68	5.50	0.75	1.38	5.83	5.63	6.25
100	1.125	4.5	0.38	3/4-16	3.32	5.44	6.25	0.75	1.38	5.83	5.63	6.25

CA

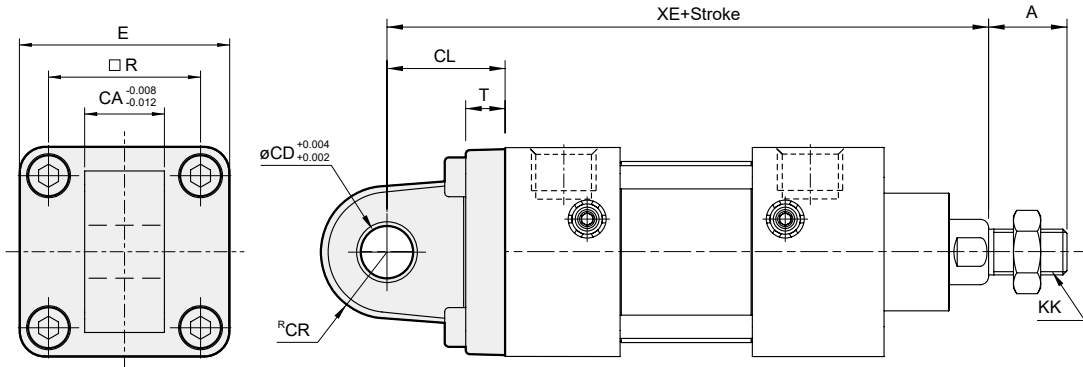

Unit: inch

Code Tube I.D.	A	CA	CD	CL	CR	E	KK	R	T	XE
40	0.75	0.75	0.5	1.125	0.63	2	7/16-20	1.43	0.375	5.75
50	0.75	0.75	0.5	1.125	0.63	2.5	7/16-20	1.84	0.375	5.75
63	0.75	0.75	0.5	1.125	0.63	3	7/16-20	2.19	0.375	5.88
80	1.125	1.25	0.75	1.875	0.87	3.75	3/4-16	2.76	0.625	7.5
100	1.125	1.25	0.75	1.875	0.87	4.5	3/4-16	3.32	0.625	7.5

CB

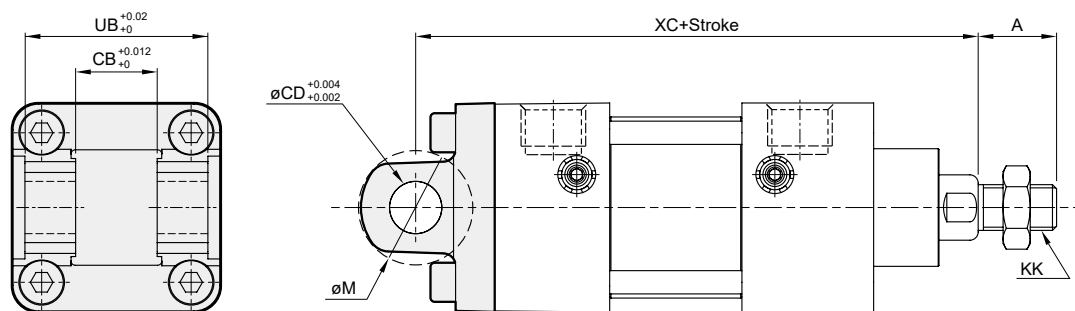

Unit: inch

Code Tube I.D.	A	CB	CD	KK	M	UB	XC
40	0.75	0.78	0.5	7/16-20	1.24	1.75	5.38
50	0.75	0.78	0.5	7/16-20	1.24	1.75	5.38
63	0.75	0.78	0.5	7/16-20	1.24	1.75	5.5
80	1.125	1.28	0.75	3/4-16	1.88	2.5	6.88
100	1.125	1.28	0.75	3/4-16	1.88	2.5	6.88

CB2

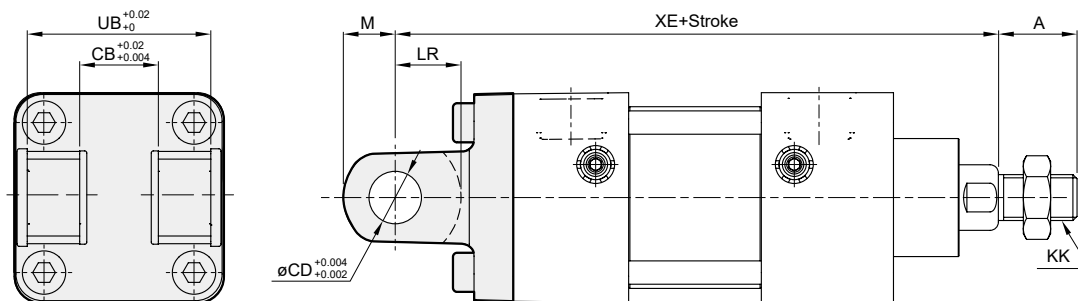

Unit: inch

Code Tube I.D.	A	CB	CD	KK	LR	M	UB	XE
40	0.75	0.75	0.5	7/16-20	0.63	0.5	1.75	5.75
50	0.75	0.75	0.5	7/16-20	0.63	0.5	1.75	5.75
63	0.75	0.75	0.5	7/16-20	0.63	0.5	1.75	5.88
80	1.125	1.25	0.75	3/4-16	1	0.75	2.5	7.5
100	1.125	1.25	0.75	3/4-16	1	0.75	2.5	7.5

STANDARD CYLINDER

mindman

TC

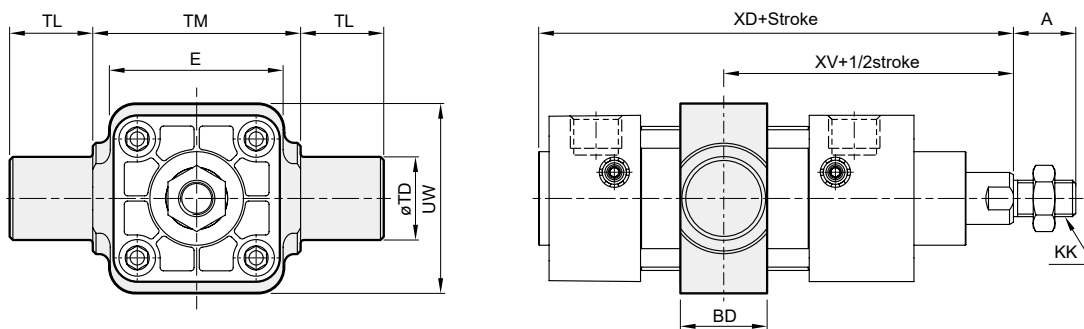

Unit: inch

Code Tube I.D.	A	BD	E	KK	TD	TM	TL	UW	XD	XV
40	0.75	1.04	2.11	7/16-20	1	2.5	1	2.28	4.94	3.2
50	0.75	1.04	2.6	7/16-20	1	3	1	2.60	5.03	3.32
63	0.75	1.1	3.09	7/16-20	1	3.5	1	3.23	5.07	3.33
80	1.125	1.18	3.7	3/4-16	1	4.5	1	4.17	6.16	4.19
100	1.125	1.22	4.49	3/4-16	1	5.25	1	4.96	6.18	4.19

I connector

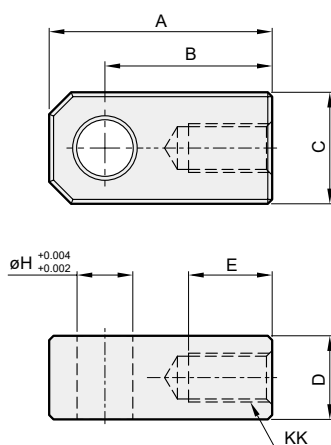

Unit: inch

Code Tube I.D.	A	B	C	D	E	H	KK
40~63	2	1.5	1	0.75	0.75	0.5	7/16-20
80~100	2.81	2.06	1.5	1.25	1.13	0.75	3/4-16

Y connector

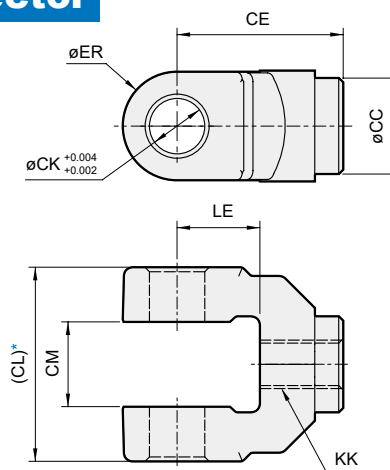

Unit: inch

Code Tube I.D.	CC	CE	CL	CM	CK	ER	KK	LE
40~63	0.87	1.5	1.75	0.765	0.5	1	7/16-20	0.75
80~100	1.34	2.38	2.5	1.265	0.75	1.5	3/4-16	1.25

* Please do not take the sand casting plate as the mounting plate, because we do not machine it. If you have this special demand, please contact our sales representative.

PIN

for CB & CB2 accessory and Y & I connector.

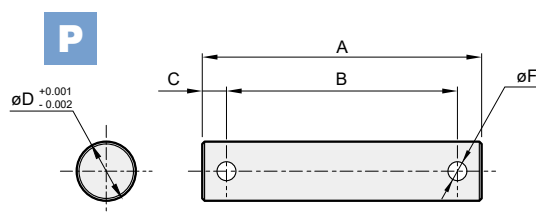

Unit: inch

Code Tube I.D.	A	B	C	D	F
40~63	2.36	1.95	0.2	0.5	0.16
80~100	3.13	2.74	0.19	0.75	0.2



Special spec



Rod end shape



Technical data



Caution for safety
(Read before installing)



Features

■ Non lubrication

Special housing and bushing enables self lubrication of piston rod.

■ High quality long service life

Hard anodised aluminium cylinder tubes offer a high resistance to corrosion and low internal friction.

■ ISO 15552 standard specification

Conforms to ISO 15552 specification enabling worldwide interchangeability.

■ Cylinder mountings

Available with comprehensive internationally recognised range of fixed and flexible mountings.

Specification



Model	MCQV		
Tube I.D. (mm)	125	160	200
Medium	Air		
Operating pressure range	0.05~1 MPa		
Proof pressure	1.5 MPa		
Ambient temperature	-5~+60°C (No freezing)		
Available speed range	50~500 mm/sec		
Sensor switch	RDC(V), RQC(V)  , RDT, RQT  , RCA 		
Sensor switch holder	R*C(V)	DT7-3	
	R*T	DT-3	
	RCA	HV4	PM16 HA5

Table for standard stroke

Tube I.D.	Stroke (mm)	Max. stroke (mm)	
		Style 11	Style 21/27
ø125	50,75,100,125,150,175,	2000	950
ø160	200,250,300,350,400,	1800	850
ø200	450,500	1500	700



* Intermediate stroke are available, please contact us.

Order example

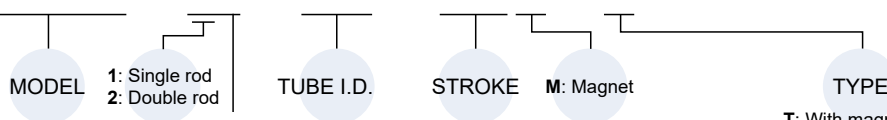
MCQV – 11 – 125 – 100M – T

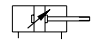

STYLE







Code	Symbol	Description
1 1		Double acting / Male thread
2 1		Double rod / Male thread
2 7		Double rod / Adjustable male thread Please mark "adjustable stroke" at order list







* Rc or NPT thread are also available, please contact us.

T: With magnet, TA/TB is assembled



* Tube, piston rod and tie rod are extended, and an extra piston is added.

Accessories & Connector

Code	Accessories					Rod nut
	LB (Purchase 2 pcs)	CA	CB	FAC	FBC	NUT
Mounting Tube I.D.						
ø125	LB-Q2-125	CA-Q2-125	CB-Q2-125	FAC-Q2-125		NUT-M27x2.0x13.5Hx41B
ø160	LB-Q2-160	CA-Q2-160	CB-Q2-160	FAC-Q2-160		
ø200	LB-Q2-200	CA-Q2-200	CB-Q2-200	FAC-Q2-200		

Code	Accessories <small>⚠ Factory assembled and shipped (self-assembled is not recommended)</small>				Connector	
	TA	TB	TC	SDS Mid section support (Stroke over 1000mm)	Y	I
Mounting Tube I.D.						
ø125	TC-Q2-125			SDS-Q2-125	Y-Q2-125	I-Q2-125
ø160	TC-Q2-160			SDS-Q2-160	Y-Q2-160	I-Q2-160
ø200	TC-Q2-200			SDS-Q2-200		

Pin

Applicable	Y&I connector	CA&CB accessories
Code	PIN-Y-P (with split pin)	PIN-CB-P (with split pin)
Fig Tube I.D.		
ø125	PIN-Q2-125-2-P	PIN-Q2-125-1-P
ø160	PIN-Q2-160-2-P	PIN-Q2-160-1-P
ø200		

Order example of self-assembled

The tube I.D. ø125 of LB accessories, Y connector and pin.

No.	Order number	Qty
1	LB-Q2-125	2
2	Y-Q2-125	1
3	PIN-Q2-125-2-P	1

* To order accessories/ connectors/ pin separately, please place orders separately according to the order codes in the above table.

Order example of factory assembled

⚠ Cylinders and accessories are distinguished by the symbol " + ".

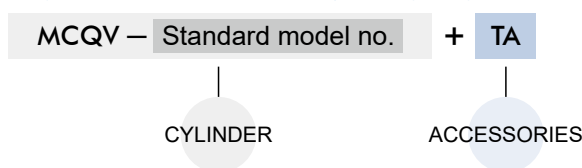

MCQV-11 Inside structure & Parts list

ISO 15552 STANDARD CYLINDER



Single rod 11 type

ø125~ø200

ø200

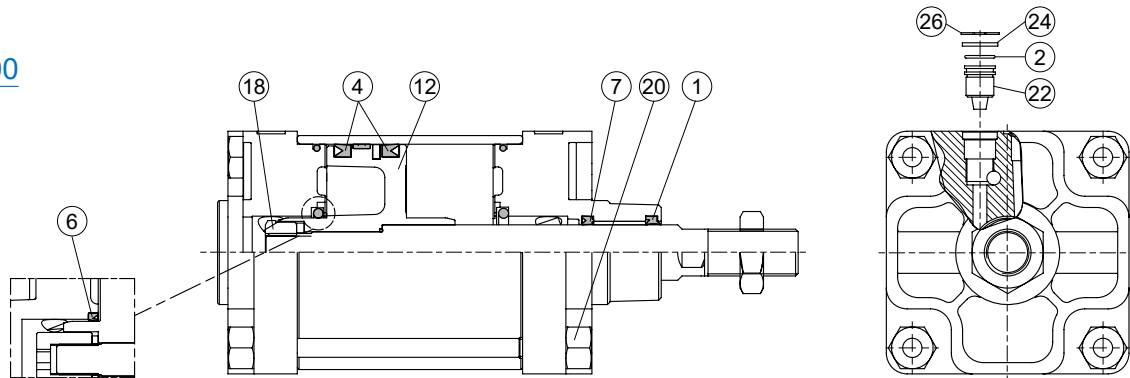

No.	Part name	Material	Q'y	Component parts (inclusion)	Repair kits (inclusion)	Note
1	Rod packing	NBR	1	●	●	
2	O-ring	NBR	2	●	●	
3	O-ring	NBR	2	●	●	
4	Piston packing	NBR	2	●	●	
5	O-ring	NBR	1	●	●	
6	Cushion packing	NBR	2	●	●*1	
7	Rod packing	NBR	1	●	●	
8	Rod cover	Aluminum alloy	1	●		
9	Head cover	Aluminum alloy	1	●		
10	Piston-R	Aluminum alloy	1			
11	Piston-H	Aluminum alloy	1			
12	Piston	Aluminum alloy	1	●		
13	Bush	Bearing alloy	1	●		
14	Magnet ring	Magnet material	1	◎		◎ Option
15	Wear ring	Resin	1	●		
16	Hex nut	Carbon steel	1	●		
17	Bolt	Carbon steel	1			
18	Piston nut	Carbon steel	1	●		
19	Washer	Carbon steel	1	●		
20	Tie rod nut	Carbon steel	8	●		
21	Tie rod washer	Carbon steel	8			
22	Needle valve	Copper alloy	2	●		
23	Insert nut	Copper alloy	2			
24	Needle valve washer	Carbon steel	2	●		
25	Cover plate	Plastic	2			
26	Snap ring	Carbon steel	2	●		
27	Cylinder tube	Aluminum alloy	1			
28	Piston rod *2	Carbon steel	1			
29	Tie rod	Carbon steel	4			

*1. Cushion packing is not included in ø200 repair kits.

*2. When customized material is bearing steel, only two-side across flat (wrench flat) is available.

MCQV-2* Inside structure & Parts list

ISO 15552 STANDARD CYLINDER



Double rod 21 / 27 type

ø125~ø200

ø200

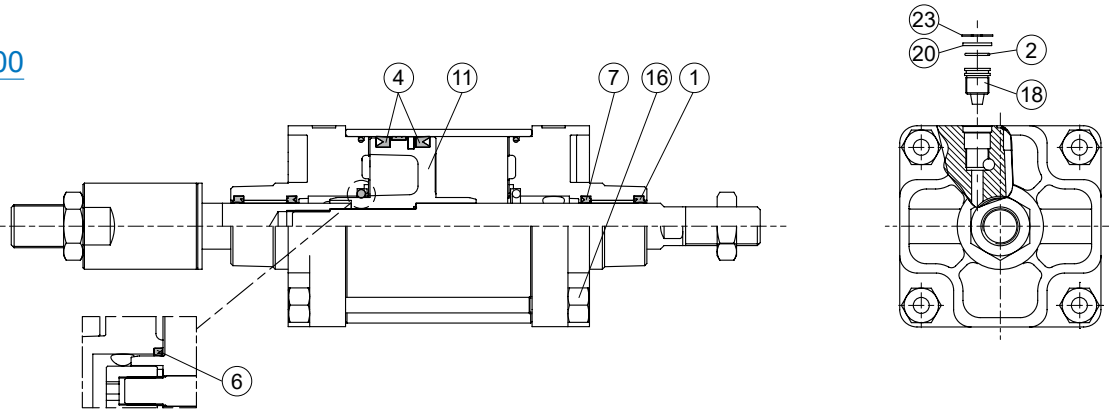

No.	21 type	27 type	Part name	Material	Q'y	Component parts (inclusion)	Repair kits (inclusion)	Note
1	●	●	Rod packing	NBR	2	●	●	
2	●	●	O-ring	NBR	2	●	●	
3	●	●	O-ring	NBR	2	●	●	
4	●	●	Piston packing	NBR	2	●	●	
5	●	●	O-ring	NBR	1	●	●	
6	●	●	Cushion packing	NBR	2	●	● *1	
7	●	●	Rod packing	NBR	2	●	●	
8	●	●	Rod cover	Aluminum alloy	2	●		
9			Piston-R	Aluminum alloy	1			
10			Piston-H	Aluminum alloy	1			
11	●	●	Piston	Aluminum alloy	1	●		
12	●	●	Bush	Bearing alloy	2	●		
13	◎	◎	Magnet ring	Magnet material	1	◎		◎ Option
14	●	●	Wear ring	Resin	1	●		
15	●	●	Screw	Carbon steel	1	●		
16	●	●	Tie rod nut	Carbon steel	8	●		
17			Tie rod washer	Carbon steel	8			
18	●	●	Needle valve	Copper alloy	2	●		
19			Insert nut	Copper alloy	2			
20	●	●	Needle valve washer	Carbon steel	2	●		
21			Cover plate	Plastic	2			
22	●	●	Hex nut	Carbon steel	1	●		
23	●	●	Snap ring	Carbon steel	2	●		
24		●	Adjustable nut	Carbon steel	1			
25		●	Gasket	PU	1			
26	●	●	Cylinder tube	Aluminum alloy	1			
27	●	●	Piston rod #1 *2	Carbon steel	1			
28	●	●	Piston rod #2 *2	Carbon steel	1			
29	●	●	Tie rod	Carbon steel	4			

*1. Cushion packing is not included in ø200 repair kits.

*2. When customized material is bearing steel, only two-side across flat (wrench flat) is available.

Order example of component parts

CP – MCQV – 2 – 125 M

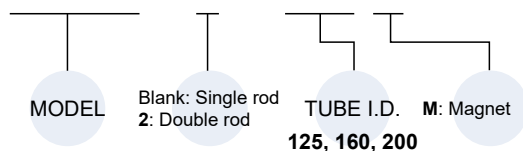

* Order example for Rc or NPT thread please contact us.

Order example of repair kits

PS – MCQV – 2 – 125 – XB6

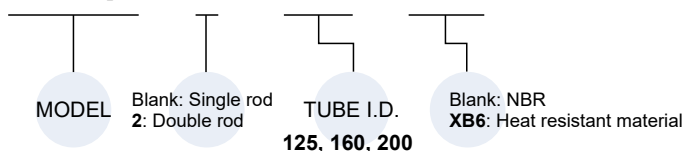

Cylinder & accessories weight





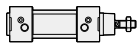
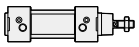
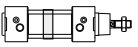





Cylinder weight

Unit: kg

Model	Basic weight MCQV-11	Basic weight (magnet) MCQV-11	Stroke 25 mm MCQV-11
Tube I.D.			
$\phi 125$	7.345	7.388	0.372
$\phi 160$	13.864	13.974	0.555
$\phi 200$	19.450	19.560	0.570

Accessories weight

Unit: kg

Model	LB	CA	CB	FAC/FBC	TA/TB/TC	SDS	Y	I	Pin	
									Y / I	CA / CB
Tube I.D.										
$\phi 125$	2.500	3.780	3.560	4.020	2.750	2.528	1.160	1.400	0.382	0.525
$\phi 160$	4.600	7.400	7.140	7.170	5.130	3.907	2.482	1.727	0.567	0.906
$\phi 200$	7.342	9.440	9.208	10.852	6.981	6.627	2.482	1.727	0.567	0.906

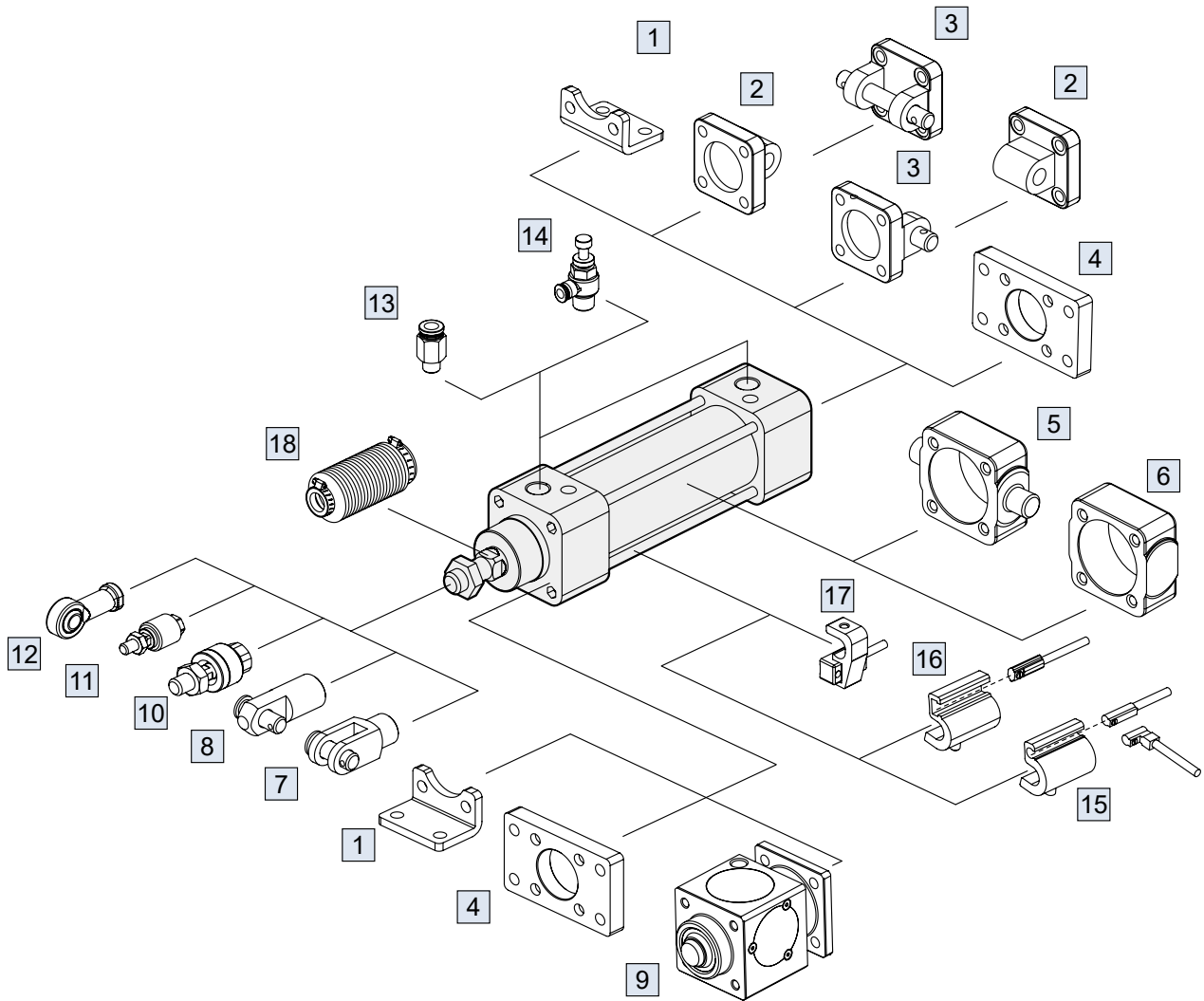

No.	Accessories	Material	Page link
1	Mounting accessories LB	Carbon steel	🔗
2	Mounting accessories CA	Cast iron	🔗
3	Mounting accessories CB+PIN	Cast iron / *1	🔗 , 🔗
4	Mounting accessories FAC/FBC	Carbon steel	🔗
5	Mounting accessories TA/TB/TC	Cast iron	🔗 , 🔗
6	Mounting accessories SDS	Cast iron	🔗
7	Accessories Y+PIN	Cast iron / *1	🔗
8	Accessories I+PIN	Carbon steel	🔗

No.	Accessories	Material	Page link
9	Locking unit MCBQV	Aluminum alloy+*2	🔗
10	Floating joint MFC	Carbon steel	🔗
11	Floating joint MFCS	Carbon steel	🔗
12	Female rod ends PHS	Carbon steel	🔗
13	Fitting PC (PISCO)	—	🔗
14	Speed controller JSC (PISCO)	—	🔗
15	Sensor switch R*C(V)+DT7-3	—	🔗
16	Sensor switch R*T+DT-3	—	🔗
17	Sensor switch RCA+HV*	—	🔗
18	Protective bellows kit	NBR	—

*1. PIN material is carbon steel.

*2. Bronze alloy.

11

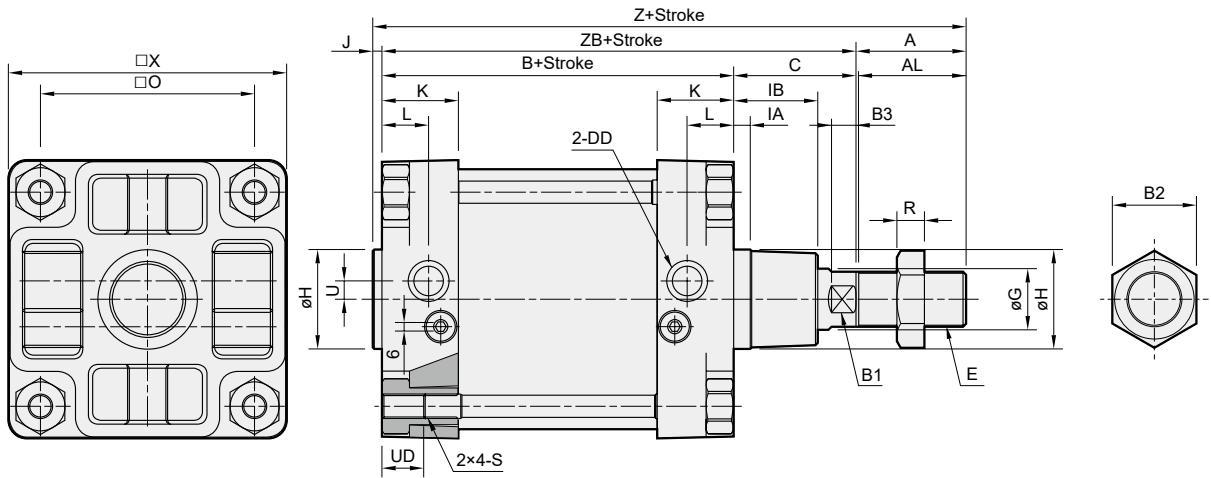

21

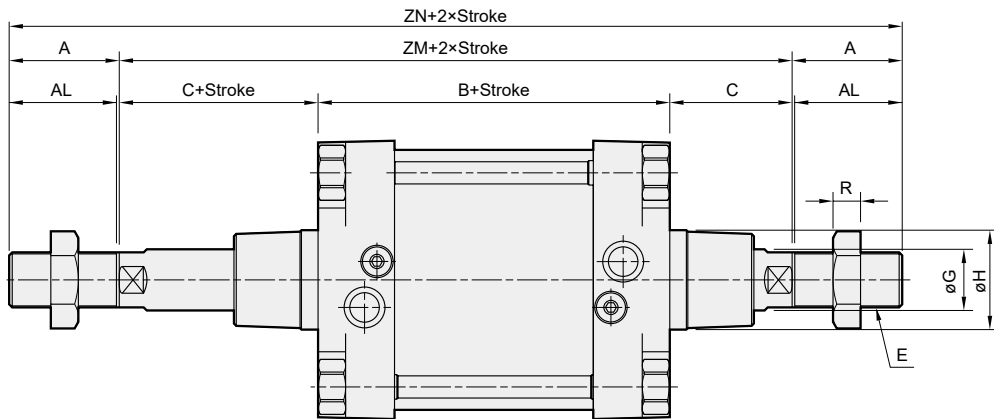

27

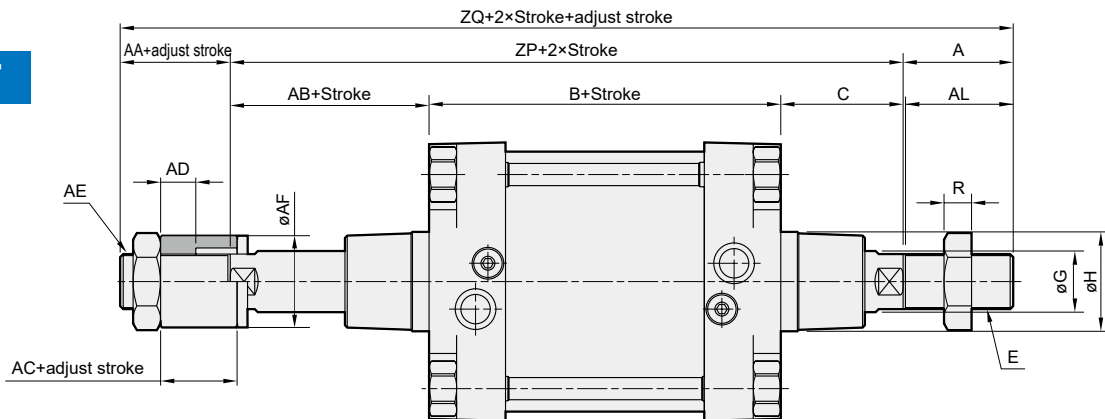

Code Tube I.D.	A	AA	AB	AC	AD	AE	AF	AL	B	B1	B2	B3	C	DD	E	G	H	IA	IB	J	K	L	O	R
125	54	38	55	30	18	M30×1.5	60	52	160	27	41	13	65	G1/2	M27×2	32	60e11	10	40	6	40	25	110	13.5
160	72	38	71	30	18	M30×1.5	60	70	180	36	55	16	80	G3/4	M36×2	40	65e11	10	55	6	50	30.5	140	18
200	72	40	70	30	18	M36×2.0	60	70	180	36	55	16	95	G3/4	M36×2	40	75e11	15	55	6	56	36.5	175	18

Code Tube I.D.	S	U	UD	X	Z	ZB	ZM	ZN	ZP	ZQ
125	M12×1.75	11	22	140	285	225	290	398	280	372
160	M16×2.0	12	27	182	338	260	340	484	331	441
200	M16×2.0	12	27	220	353	275	370	514	369.5	457

LB

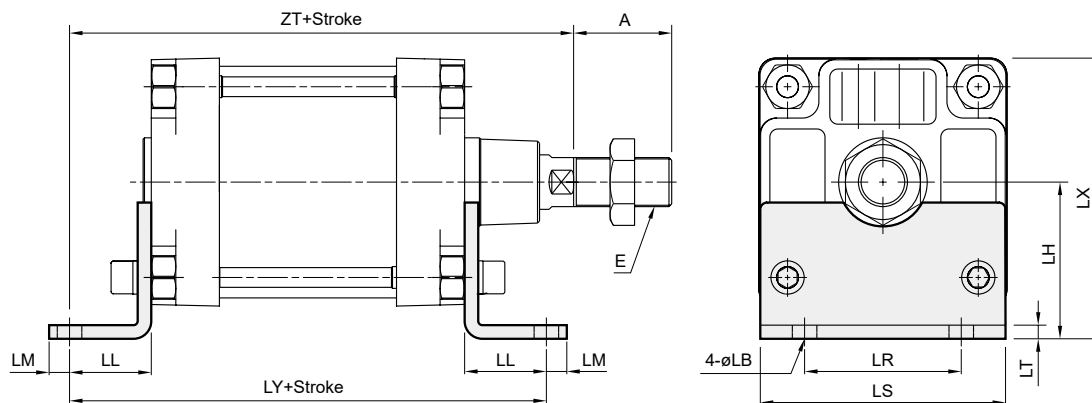

Code Tube I.D.	A	E	LB	LH	LL	LM	LR	LS	LT	LX	LY	ZT
125	54	M27×2.0	16	90	45	25	90	140	9	160	250	270
160	72	M36×2.0	18	115	60	15	115	180	10	206	300	320
200	72	M36×2.0	24	135	70	35	135	220	12	245	320	345

FAC

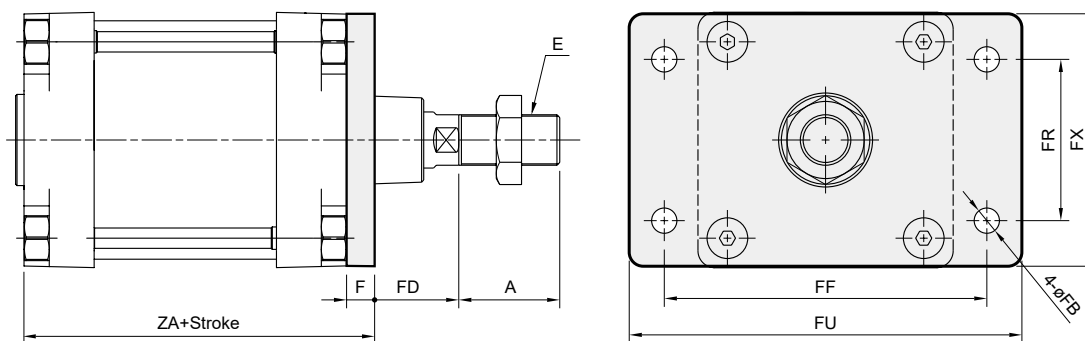

FBC

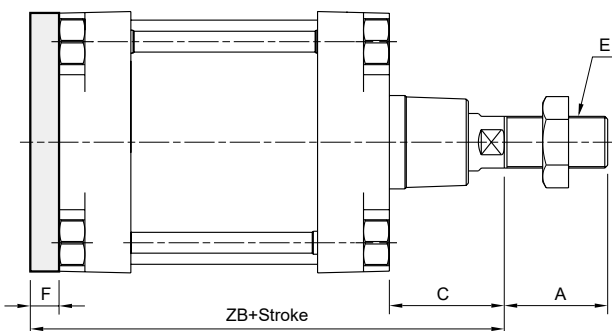

Code Tube I.D.	A	E	F	FB	FD	FF	FR	FU	FX	ZA	ZB
125	54	M27×2.0	20	16	45	180	90	210	140	180	245
160	72	M36×2.0	20	18	60	230	115	280	180	200	280
200	72	M36×2.0	25	22	70	270	135	320	220	205	300

CA

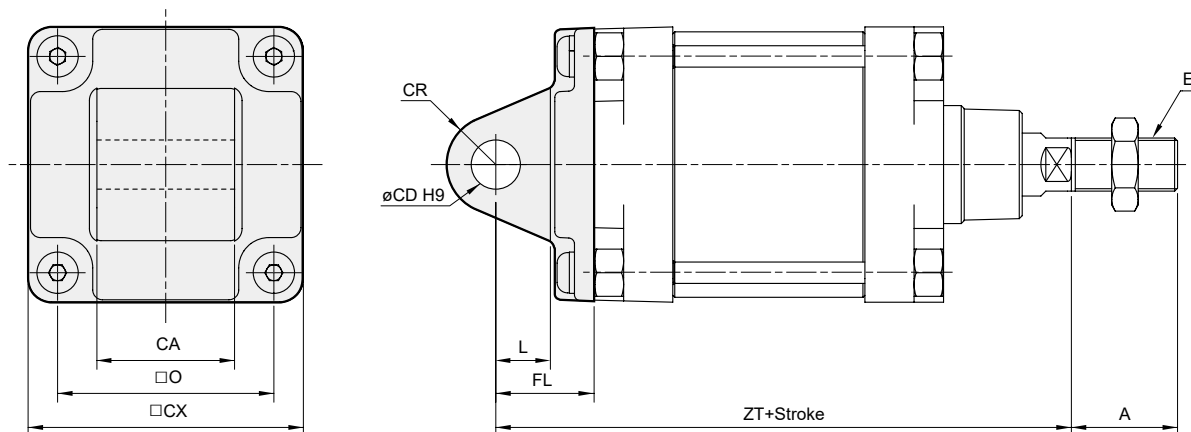

Code Tube I.D.	A	CA	CD	CR	CX	E	FL	L	O	ZT
125	54	69.5 ⁰ _{-0.7}	25	R25	139	M27×2.0	50	30	110	275
160	72	89.5 ⁰ _{-0.7}	30	R30	178	M36×2.0	55	35	140	315
200	72	90 ^{-0.5} _{-1.2}	30	R30	218	M36×2.0	60	35	175	335

CB

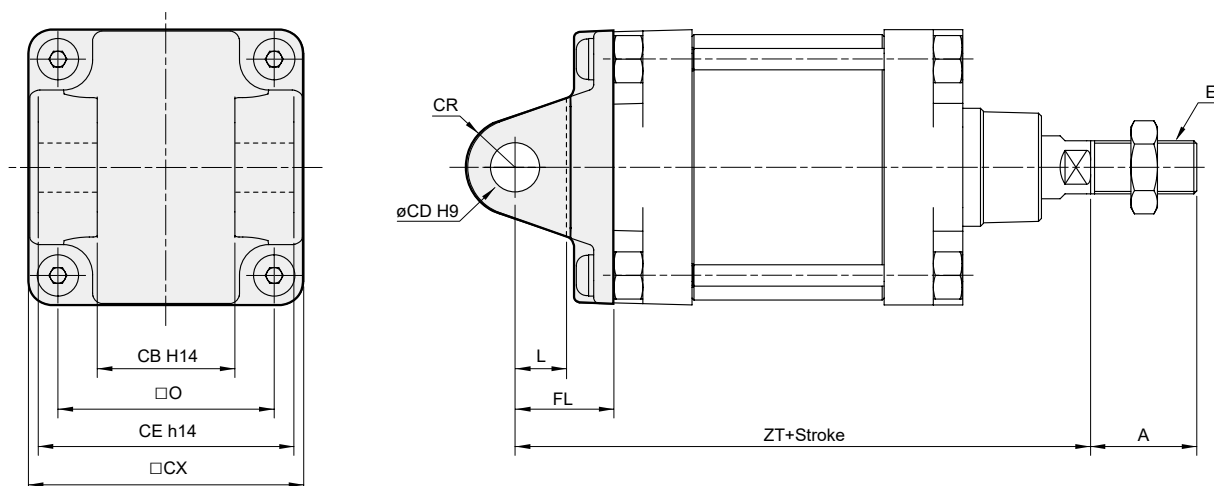

Code Tube I.D.	A	CB	CD	CE	CR	CX	E	FL	L	O	ZT
125	54	70	25	130	R25	139	M27×2.0	50	30	110	275
160	72	90	30	170	R30	178	M36×2.0	55	35	140	315
200	72	90	30	170	R30	218	M36×2.0	60	35	175	335

TC

SDS

Mid section support
Stroke over 1000mm

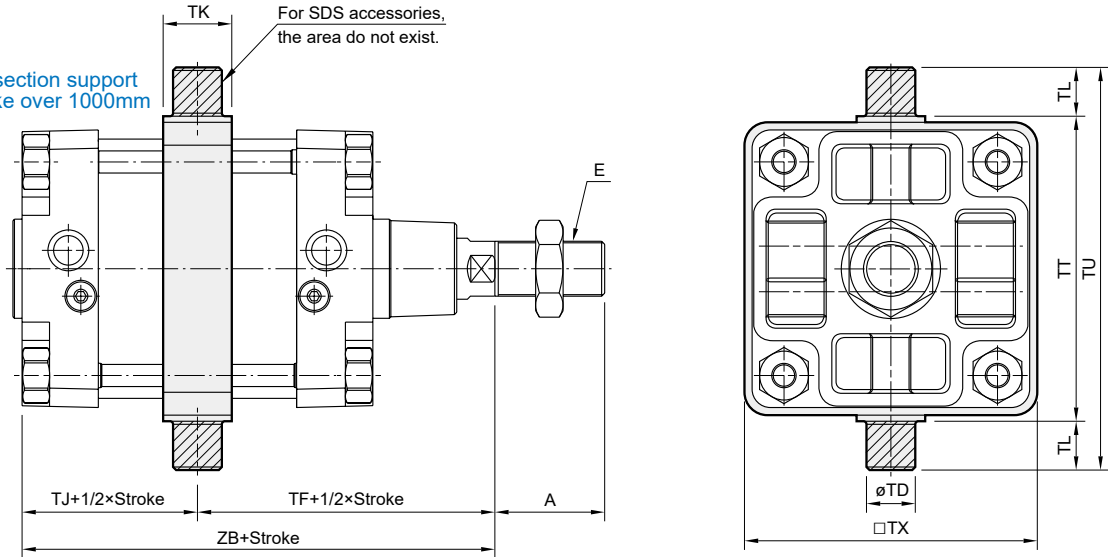

Code Tube I.D.	A	E	TD	TF	TJ	TK	TL	TT		TU	TX	ZB
								TC	SDS			
125	54	M27×2.0	25e9	145	80	40	25	160	158	210	155	225
160	72	M36×2.0	32e9	170	90	45	32	200	198	264	192	260
200	72	M36×2.0	32e9	185	90	45	32	250	250	314	240	275

TA

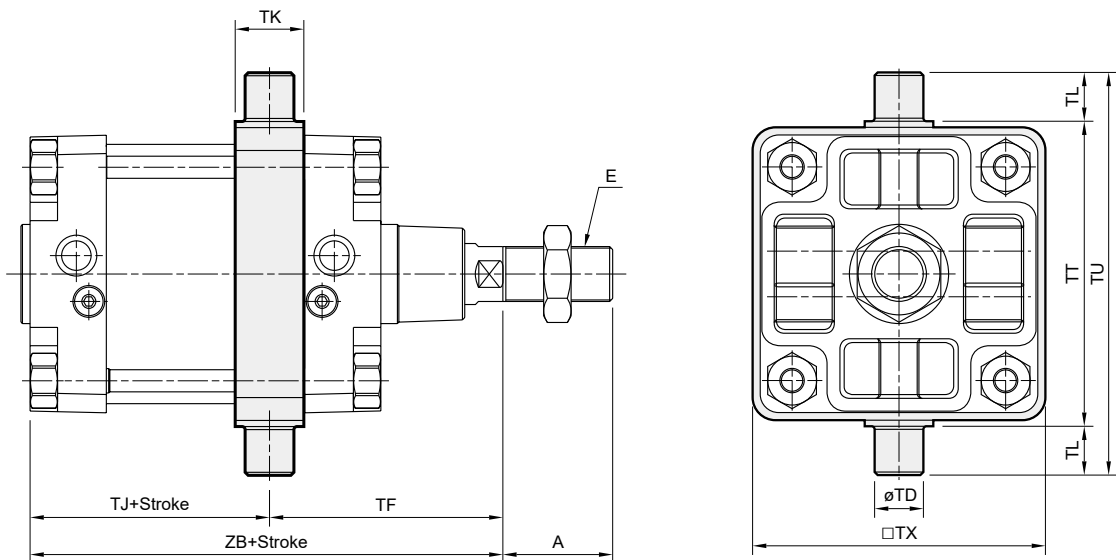

Code Tube I.D.	A	E	TD	TF	Without magnet		Magnet		TK	TL	TT	TX	TU
					TJ	ZB	TJ	ZB					
125	54	M27×2.0	25e9	125	100	225	146	271	40	25	160	155	210
160	72	M36×2.0	32e9	152.5	107.5	260	157.5	310	45	32	200	192	264
200	72	M36×2.0	32e9	173.5	101.5	275	145.5	319	45	32	250	240	275

TB

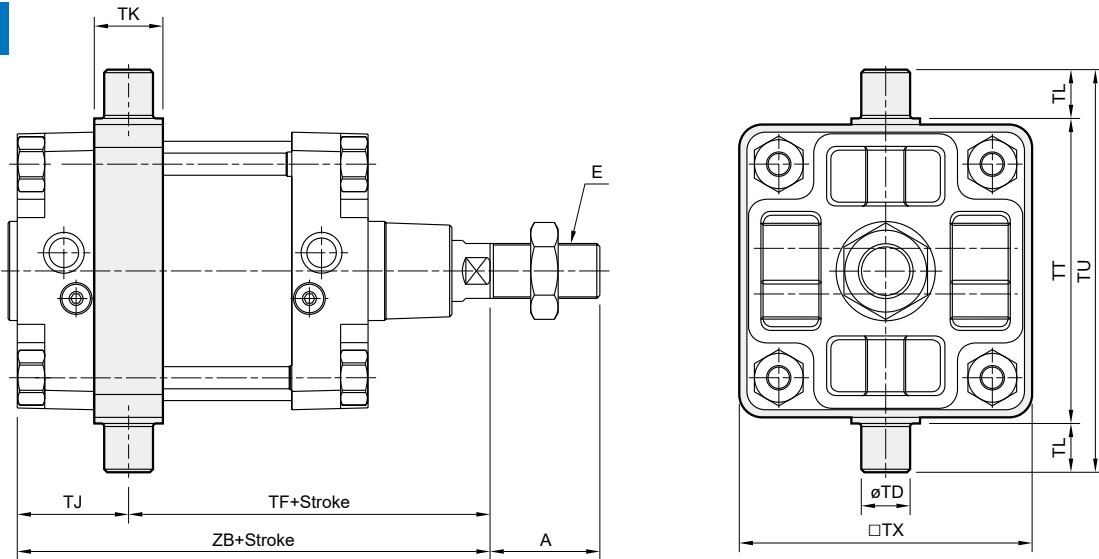

Code Tube I.D.	A	E	TD	TJ	Without magnet		Magnet		TK	TL	TT	TX	TU
					TF	ZB	TF	ZB					
125	54	M27×2.0	25e9	60	165	225	211	271	40	25	160	155	210
160	72	M36×2.0	32e9	72.5	187.5	260	237.5	310	45	32	200	192	264
200	72	M36×2.0	32e9	78.5	196.5	275	240.5	319	45	32	250	240	275

Installation of sensor switch

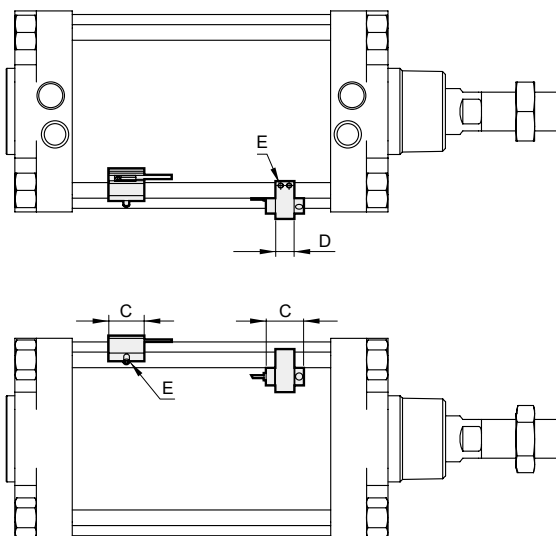
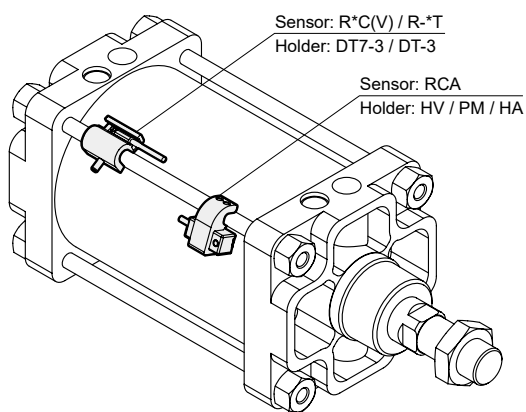

Code Tube I.D.	Sensor switch	Holder	C	D	E
125	RCA	HV4	26	13	M4×10L
160	RCA	PM16	26	12	M4×10L
200	RCA	HA5	26	15	M4×16L

Code Tube I.D.	Sensor switch	Holder	C	E
125	R*C(V) / R*T	DT7-3 / DT-3	25	M4×12L
160	R*C(V) / R*T	DT7-3 / DT-3	25	M4×12L
200	R*C(V) / R*T	DT7-3 / DT-3	25	M4×12L

Y connector

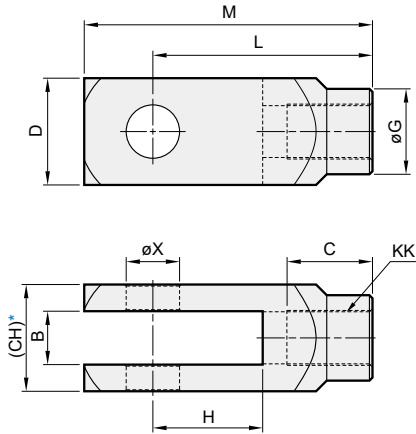

I connector

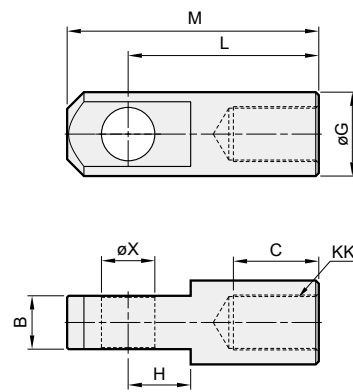

* Please do not take the sand casting plate as the mounting plate, because we do not machine it.
If you have this special demand, please contact our sales representative.

Code Tube I.D.	B		C		CH		D		G		H		KK		L		M		X ^{F7}	
	Y	I	Y	I	Y	I	Y	I	Y	I	Y	I	Y	I	Y	I	Y	I	Y	I
125	30 ^{+0.52} ₀	30 ^{-0.2} _{-0.3}	56	51	55	—	55	—	48	55	54	40	M27×2.0	110	110	148	145	30 ^{+0.04} _{+0.02}	30 ^{+0.04} _{+0.02}	
160	35 ^{+0.62} ₀	35 ^{-0.2} _{-0.3}	56	56	70	—	70	—	56	55	72	41	M36×2.0	144	125	189	165	35 ^{+0.05} _{+0.02}	35 ^{+0.05} _{+0.02}	
200	35 ^{+0.62} ₀	35 ^{-0.2} _{-0.3}	56	56	70	—	70	—	56	55	72	41	M36×2.0	144	125	189	165	35 ^{+0.05} _{+0.02}	35 ^{+0.05} _{+0.02}	

PIN

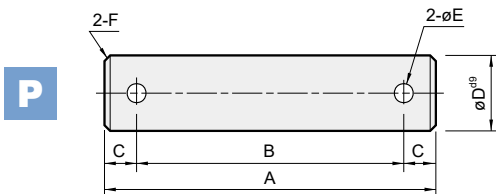

for $\phi 125$

Code Type	A	B	C	D ^{#9}	E	F	Split pin
CB	157	140	8.5	$\phi 25$ ^{-0.07} _{-0.12}	5	1.5	5×36L
Y	81	64	8.5	$\phi 30$ ^{-0.07} _{-0.12}	6.3	1.5	6.3×40L

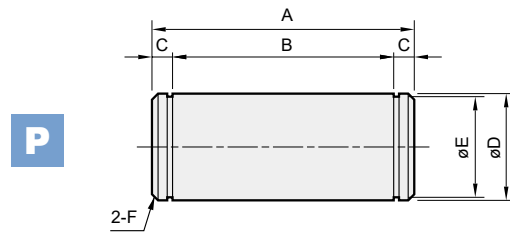

for $\phi 160, \phi 200$

Code Type	A	B	C	D	E	F	Snap ring
CB	186	172	7	30 ^{h8} _{-0.05} ^{-0.09}	28.6 ⁰ _{-0.21}	2	STW-30
Y	86	72	7	35 ^{h7} ₋₀ ^{-0.03}	33 ⁰ _{-0.25}	2	STW-35



Features



Video



Special spec



Rod end shape



Technical data



Caution for safety
(Read before installing)

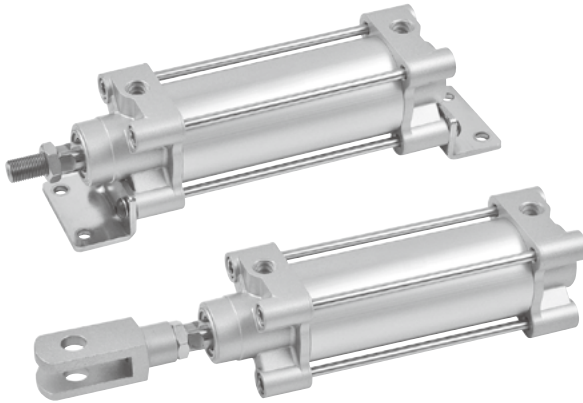

Features

■ Non lubrication

Special housing and bushing enable self lubrication of piston rod.

■ High quality long service life

Hard anodised aluminium cylinder tubes offer high resistance to corrosion and low internal friction.

■ Automatic air cushioning

Pneumatic cushioning at both ends without adjusting.

■ Low noise level

Add cushion pad to reduce impact sound and vibration.

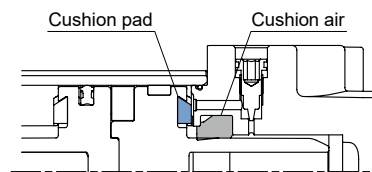

■ ISO 15552 standard specification

Conforms to ISO 15552 specification enabling worldwide interchangeability.

■ Cylinder mountings

Available with comprehensive internationally recognised range of fixed and flexible mountings.

Table for standard stroke

Tube I.D.	Stroke (mm)	Max. stroke(mm)	
		Style 11	Style 21/27
ø32,40	50, 75, 100, 125, 150, 175,	1800	850
ø50,63	200, 250, 300, 350, 400, 450,	2000	950
ø80,100	500, 600, 700, 800	2500	1200



* Please contact us if the stroke is out of specification.

Order example

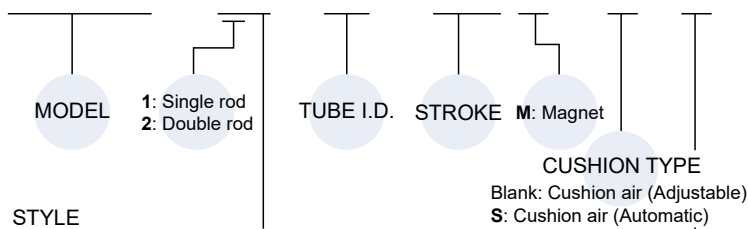
MCQV3 - 11 - 63 - 100 M - S - T





STYLE

Code	Symbol	Description
1 1		Double acting / Male thread
2 1		Double rod / Male thread
2 7		Double rod / Adjustable male thread Please mark "adjustable stroke" at order list

* Rc or NPT thread are also available, please contact us.





Specification





Model	MCQV3		
Tube I.D. (mm)	32,40	50,63	80,100
Medium	Air		
Operating pressure range	0.05~1 MPa		
Proof pressure	1.5 MPa		
Ambient temperature	-5~+60°C (No freezing)		
Available speed range	50~500 mm/sec		
Sensor switch	RDC(V), RQC(V)  , RDT, RQT  , RCA 		
Sensor switch holder	R*C(V)	DT7-1	DT7-2
	R*T	DT-1	DT-2
	RCA	HV1	HV2
		HV3	







T: With magnet, TA/TB is assembled

* Tube, piston rod and tie rod are extended, and an extra piston is added.



Accessories & Connector

Accessories							
Code	LB (Purchase 2 pcs)	CA	CA2	CB	CB2	CDB (Purchase CB+PIN)	CDB2 (Purchase CB+PIN)
Mounting Tube I.D.							
ø32	LB-Q2-32	CA-Q2-32	CA2-Q2-32	CB-Q2-32	CB2-Q2-32	CDB-Q2-32	CDB2-Q2-32
ø40	LB-Q2-40	CA-Q2-40	CA2-Q2-40	CB-Q2-40	CB2-Q2-40	CDB-Q2-40	CDB2-Q2-40
ø50	LB-Q2-50	CA-Q2-50	CA2-Q2-50	CB-Q2-50	CB2-Q2-50	CDB-Q2-50	CDB2-Q2-50
ø63	LB-Q2-63	CA-Q2-63	CA2-Q2-63	CB-Q2-63	CB2-Q2-63	CDB-Q2-63	CDB2-Q2-63
ø80	LB-Q2-80	CA-Q2-80	CA2-Q2-80	CB-Q2-80	CB2-Q2-80	CDB-Q2-80	CDB2-Q2-80
ø100	LB-Q2-100	CA-Q2-100	CA2-Q2-100	CB-Q2-100	CB2-Q2-100	CDB-Q2-100	CDB2-Q2-100

Accessories				Rod nut	
Code	FAC	FBC	FAC2	FBC2	NUT
Mounting Tube I.D.					
ø32	FAC-Q2-32		FAC2-Q2-32		NUT-M10x1.25x5Hx17B
ø40	FAC-Q2-40		FAC2-Q2-40		NUT-M12x1.25x6Hx19B
ø50	FAC-Q2-50		FAC2-Q2-50		NUT-M16x1.5x8Hx24B
ø63	FAC-Q2-63		FAC2-Q2-63		
ø80	FAC-Q2-80		FAC2-Q2-80		NUT-M20x1.5x10Hx30B
ø100	FAC-Q2-100		FAC2-Q2-100		

Accessories				Connector			
Code	TA	TB	TC	SDS Mid section support (Stroke over 1000mm)	Y	I	YS (Y+Floating pin)
Mounting Tube I.D.							
ø32	TC-Q2-32			SDS-Q2-32	Y-Q2-32	I-Q2-32	YS-Q2-32
ø40	TC-Q2-40			SDS-Q2-40	Y-Q2-40	I-Q2-40	YS-Q2-40
ø50	TC-Q2-50			SDS-Q2-50	Y-Q2-50	I-Q2-50	YS-Q2-50
ø63	TC-Q2-63			SDS-Q2-63			
ø80	TC-Q2-80			SDS-Q2-80	Y-Q2-80	I-Q2-80	YS-Q2-80
ø100	TC-Q2-100			SDS-Q2-100			

Pin

Applicable	YS connector	Y&I connector	CA&CB accessories
Code	PIN-S	PIN-Y-P (with split pin)	PIN-CB-P (with split pin)
Fig Tube I.D.			
ø32	PIN-Q2-32-S	PIN-Q2-32-2-P	PIN-Q2-32-1-P
ø40	PIN-Q2-40-S	PIN-Q2-40-2-P	PIN-Q2-40-1-P
ø50	PIN-Q2-50-S	PIN-Q2-50-2-P	PIN-Q2-50-1-P
ø63			PIN-Q2-63-1-P
ø80	PIN-Q2-80-S	PIN-Q2-80-2-P	PIN-Q2-80-1-P
ø100			PIN-Q2-100-1-P

Order example of self-assembled

The tube I.D. ø40 of LB accessories, Y connector and pin.

No.	Order number	Qty
1	LB-Q2-40	2
2	Y-Q2-40	1
3	PIN-Q2-40-2-P	1

* To order accessories/ connectors/ pin separately, please place orders separately according to the order codes in the above table.

Order example of factory assembled

△ Cylinders and accessories are distinguished by the symbol " + ".

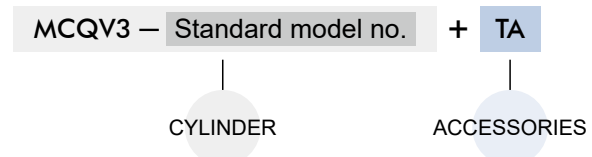

MCQV3-11 Inside structure & Parts list

ISO 15552 **STANDARD CYLINDER**



Single rod 11 type

Cushion air (Adjustable)

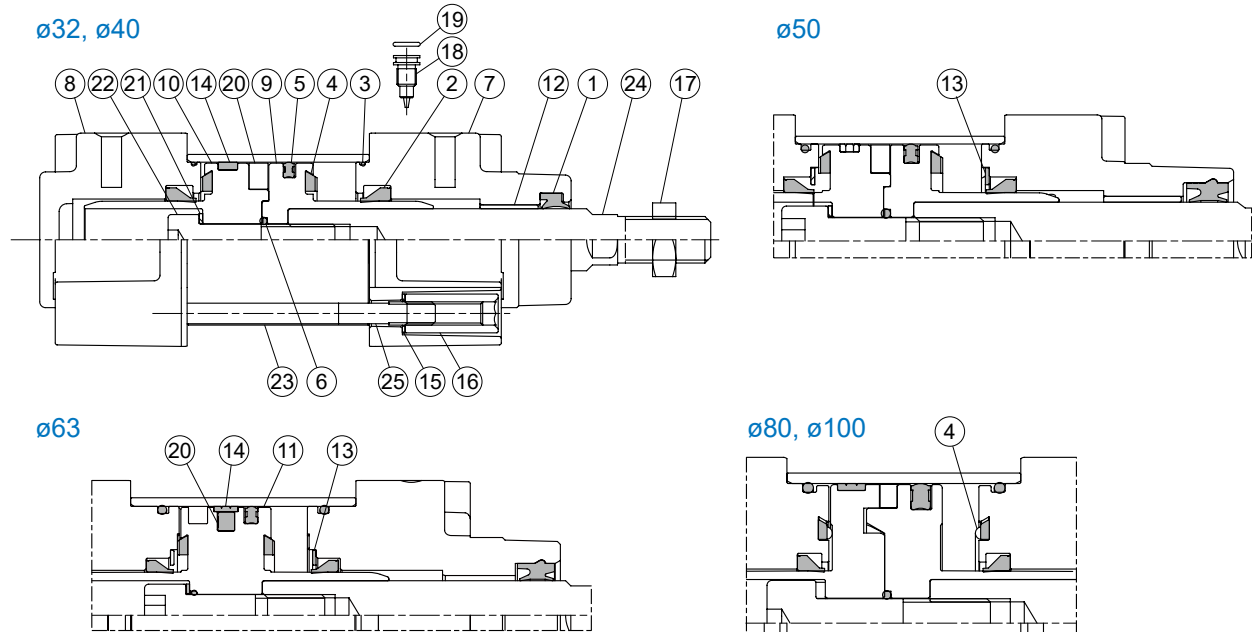

No.	Part name	Material	Q'y	Component parts (inclusion)	Repair kits (inclusion)	Note
1	Rod packing	NBR / TPU	1	●	●	ø50, 63: TPU
2	Cushion packing	NBR	2	●	●	
3	O-ring	NBR	2	●	●	
4	Cushion pad	NBR	2	●	●	
5	Piston packing	NBR	1	●	●	
6	O-ring	NBR	1	●	●	
7	Rod cover	Aluminum alloy	1	●		
8	Head cover	Aluminum alloy	1	●		
9	Piston #1	Aluminum alloy	1	●		
10	Piston #2	Aluminum alloy	1	●		
11	Piston	Aluminum alloy	1	●		Only for ø63
12	Bush	Bearing alloy	1	●		
13	Washer	Carbon steel	2	●		Only for ø50, ø63
14	Wear ring	Resin	1	●		
15	Washer	Aluminum alloy	8	●		
16	Tie rod nut	Carbon steel	8	●		
17	Piston rod nut	Carbon steel	1	●		
18	Needle valve	Copper alloy	2	●		
19	O-ring	NBR	2	●		
20	Magnet ring	Magnet material	1	◎		◎ Option
21	Washer	Aluminum alloy	1	●		
22	Hex bolt	Carbon steel	1	●		
23	Cylinder tube	Aluminum alloy	1			
24	Piston rod *1	Carbon steel	1			
25	Tie rod	Carbon steel	4			

*1. When customized material is bearing steel, only two-side across flat (wrench flat) is available.

MCQV3-11-S Inside structure & Parts list

ISO 15552 **STANDARD CYLINDER**



Single rod 11 type

Cushion air (Automatic)

ø32, ø40

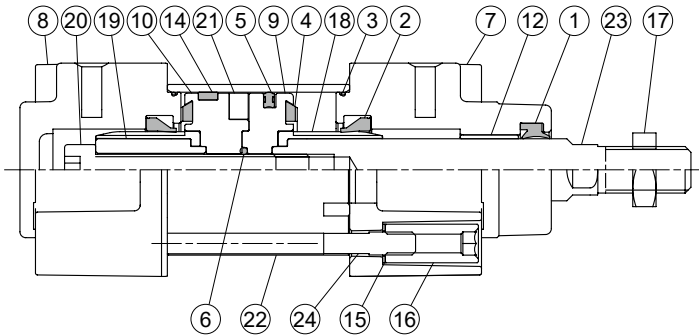

ø50

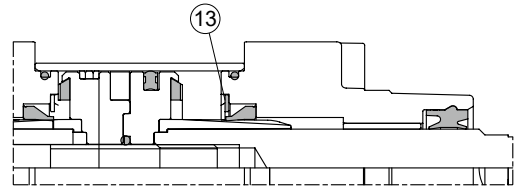

ø63

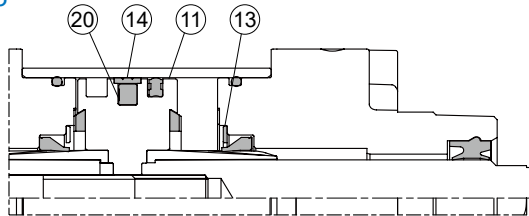

ø80, ø100

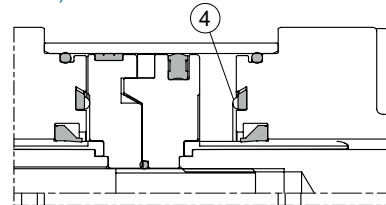

No.	Part name	Material	Q'y	Component parts (inclusion)	Repair kits (inclusion)	Note
1	Rod packing	NBR / TPU	1	●	●	ø50, 63: TPU
2	Cushion packing	NBR	2	●	●	
3	O-ring	NBR	2	●	●	
4	Cushion pad	NBR	2	●	●	
5	Piston packing	NBR	1	●	●	
6	O-ring	NBR	1	●	●	
7	Rod cover	Aluminum alloy	1	●		
8	Head cover	Aluminum alloy	1	●		
9	Piston #1	Aluminum alloy	1	●		
10	Piston #2	Aluminum alloy	1	●		
11	Piston	Aluminum alloy	1	●		Only for ø63
12	Bush	Bearing alloy	1	●		
13	Washer	Carbon steel	2	●		Only for ø50, ø63
14	Wear ring	Resin	1	●		
15	Washer	Aluminum alloy	8	●		
16	Tie rod nut	Carbon steel	8	●		
17	Piston rod nut	Carbon steel	1	●		
18	Shock absorber axis	Resin	2	●		
19	Piston nut	Aluminum alloy	1	●		
20	Hex bolt	Carbon steel	1	●		
21	Magnet ring	Magnet material	1	◎		◎ Option
22	Cylinder tube	Aluminum alloy	1			
23	Piston rod *1	Carbon steel	1			
24	Tie rod	Carbon steel	4			

*1. When customized material is bearing steel, only two-side across flat (wrench flat) is available.

MCQV3-21/27 Inside structure & Parts list

ISO 15552 STANDARD CYLINDER



Double rod 21 / 27 type

Cushion air (Adjustable)

ø32, ø40

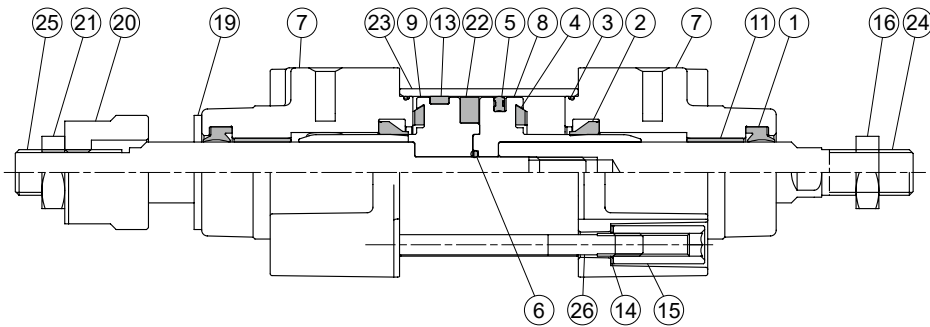

ø50

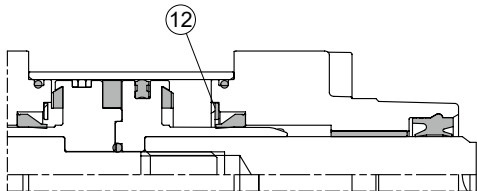

ø63

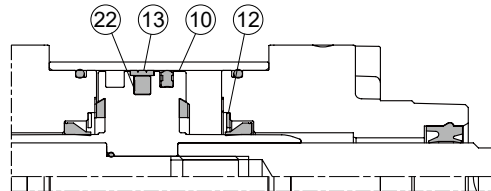

ø80, ø100

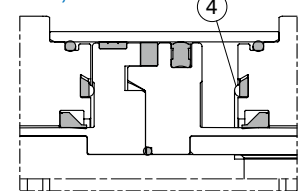

No.	Part name	Material	Q'y	Component parts (inclusion)		Repair kits (inclusion)	Note
				21 type	27 type		
1	Rod packing	NBR / TPU	2	●	●	●	ø50, 63: TPU
2	Cushion packing	NBR	2	●	●	●	
3	O-ring	NBR	2	●	●	●	
4	Cushion pad	NBR	2	●	●	●	
5	Piston packing	NBR	1	●	●	●	
6	O-ring	NBR	1	●	●	●	
7	Rod cover	Aluminum alloy	2	●	●		
8	Piston #1	Aluminum alloy	1	●	●		
9	Piston #2	Aluminum alloy	1	●	●		
10	Piston	Aluminum alloy	1	●	●		Only for ø63
11	Bush	Bearing alloy	2	●	●		
12	Washer	Carbon steel	2	●	●		Only for ø50, ø63
13	Wear ring	Resin	1	●	●		
14	Washer	Carbon steel	8	●	●		
15	Tie rod nut	Carbon steel	8	●	●		
16	Piston rod nut	Carbon steel	1	●	●		
17	Needle valve	Copper alloy	2	●	●		
18	O-ring	NBR	2	●	●		
19	Gasket	PU	1		●		
20	Adjustable nut	Carbon steel	1		●		
21	Hex nut	Carbon steel	1		●		
22	Magnet ring	Magnet material	1	◎	◎		◎ Option
23	Cylinder tube	Aluminum alloy	1				
24	Piston rod #1 *1	Carbon steel	1				
25	Piston rod #2 *1	Carbon steel	1				
26	Tie rod	Carbon steel	4				

*1. When customized material is bearing steel, only two-side across flat (wrench flat) is available.

MCQV3-21/27-S Inside structure & Parts list

ISO 15552 **STANDARD CYLINDER**



Double rod 21 / 27 type

Cushion air (Automatic)

ø32, ø40

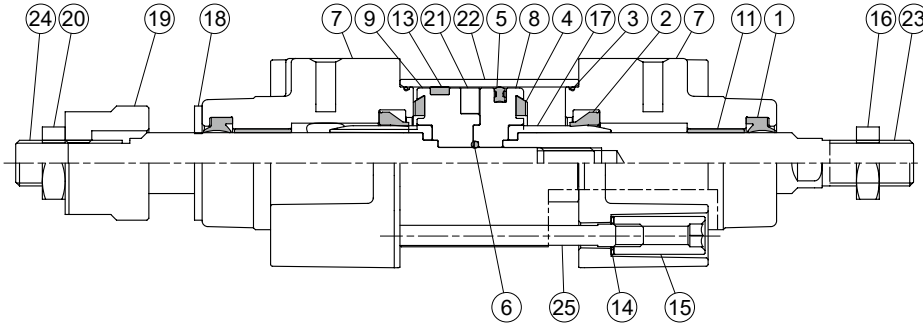

ø50

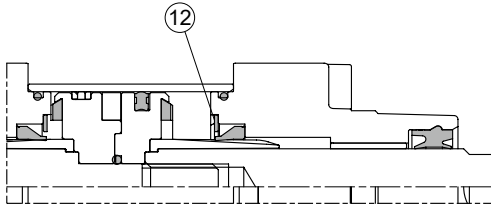

ø63

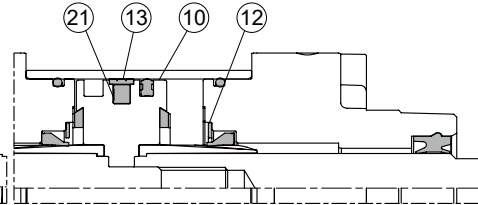

ø80, ø100

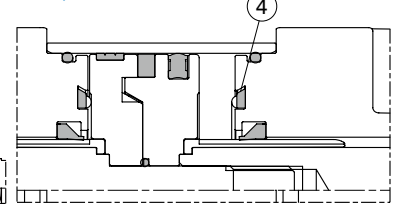

No.	Part name	Material	Q'y	Component parts (inclusion)		Repair kits (inclusion)	Note
				21 type	27 type		
1	Rod packing	NBR / TPU	2	●	●	●	ø50, 63: TPU
2	Cushion packing	NBR	2	●	●	●	
3	O-ring	NBR	2	●	●	●	
4	Cushion pad	NBR	2	●	●	●	
5	Piston packing	NBR	1	●	●	●	
6	O-ring	NBR	1	●	●	●	
7	Rod cover	Aluminum alloy	2	●	●		
8	Piston #1	Aluminum alloy	1	●	●		
9	Piston #2	Aluminum alloy	1	●	●		
10	Piston	Aluminum alloy	1	●	●		Only for ø63
11	Bush	Bearing alloy	2	●	●		
12	Washer	Carbon steel	2	●	●		Only for ø50, ø63
13	Wear ring	Resin	1	●	●		
14	Washer	Carbon steel	8	●	●		
15	Tie rod nut	Carbon steel	8	●	●		
16	Piston rod nut	Carbon steel	1	●	●		
17	Shock absorber axis	Resin	2	●	●		
18	Gasket	PU	1		●		
19	Adjustable nut	Carbon steel	1		●		
20	Hex nut	Carbon steel	1		●		
21	Magnet ring	Magnet material	1	◎	◎		◎ Option
22	Cylinder tube	Aluminum alloy	1				
23	Piston rod #1 *1	Carbon steel	1				
24	Piston rod #2 *1	Carbon steel	1				
25	Tie rod	Carbon steel	4				

*1. When customized material is bearing steel, only two-side across flat (wrench flat) is available.

Order example of component parts

CP – MCQV3 – 2 – 63 M S

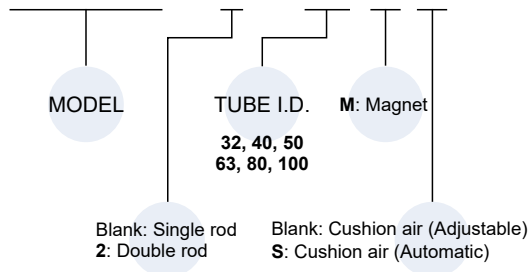

Order example of repair kits

PS – MCQV3 – 2 – 63 S – XB6

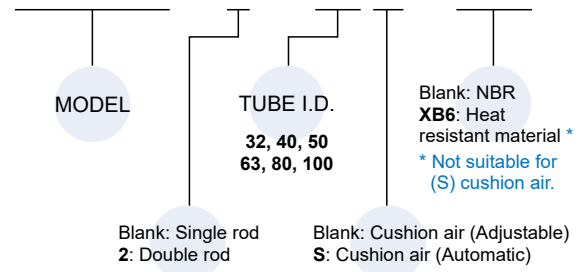

* Order example for Rc or NPT thread please contact us.

Cylinder & accessories weight

Cylinder weight

Unit: kg

Model	Basic weight MCQV3-11	Basic weight (magnet) MCQV3-11	Basic weight MCQV3-11-S	Basic weight (magnet) MCQV3-11-S	Stroke 25 mm MCQV3-11-(S)
Tube I.D.					
ø32	0.510	0.516	0.45	0.456	0.05
ø40	0.717	0.729	0.697	0.709	0.068
ø50	1.114	1.131	1.101	1.118	0.108
ø63	1.689	1.709	1.673	1.693	0.125
ø80	2.464	2.491	2.445	2.472	0.187
ø100	3.682	3.717	3.613	3.648	0.210

Accessories weight

Unit: kg

Model	LB	CA	CA2	CB	CB2	CDB	CDB2	FAC/ FBC	FAC2/ FBC2	TA/TB/TC	SDS
Tube I.D.											
ø32	0.163	0.213	0.07	0.185	0.07	0.170	0.06	0.235	0.07	0.208	0.157
ø40	0.211	0.253	0.09	0.211	0.10	0.230	0.08	0.265	0.09	0.282	0.179
ø50	0.315	0.390	0.16	0.352	0.15	0.410	0.12	0.460	0.17	0.377	0.289
ø63	0.395	0.670	0.23	0.544	0.23	0.550	0.18	0.684	0.20	0.675	0.474
ø80	0.816	1.076	0.40	0.982	0.45	0.870	0.28	1.508	0.40	1.025	0.846
ø100	1.014	1.587	0.50	1.493	0.60	1.400	0.45	1.975	0.56	1.680	1.373

Model	Y	I	Pin		YS
			Y / I	CA / CB	
Tube I.D.					
ø32	0.067	0.082	0.016	0.036	0.018
ø40	0.115	0.141	0.029	0.057	0.031
ø50	0.272	0.334	0.067	0.063	0.070
ø63	0.272	0.334	0.067	0.128	0.070
ø80	0.551	0.553	0.142	0.158	0.150
ø100	0.551	0.553	0.142	0.292	0.150

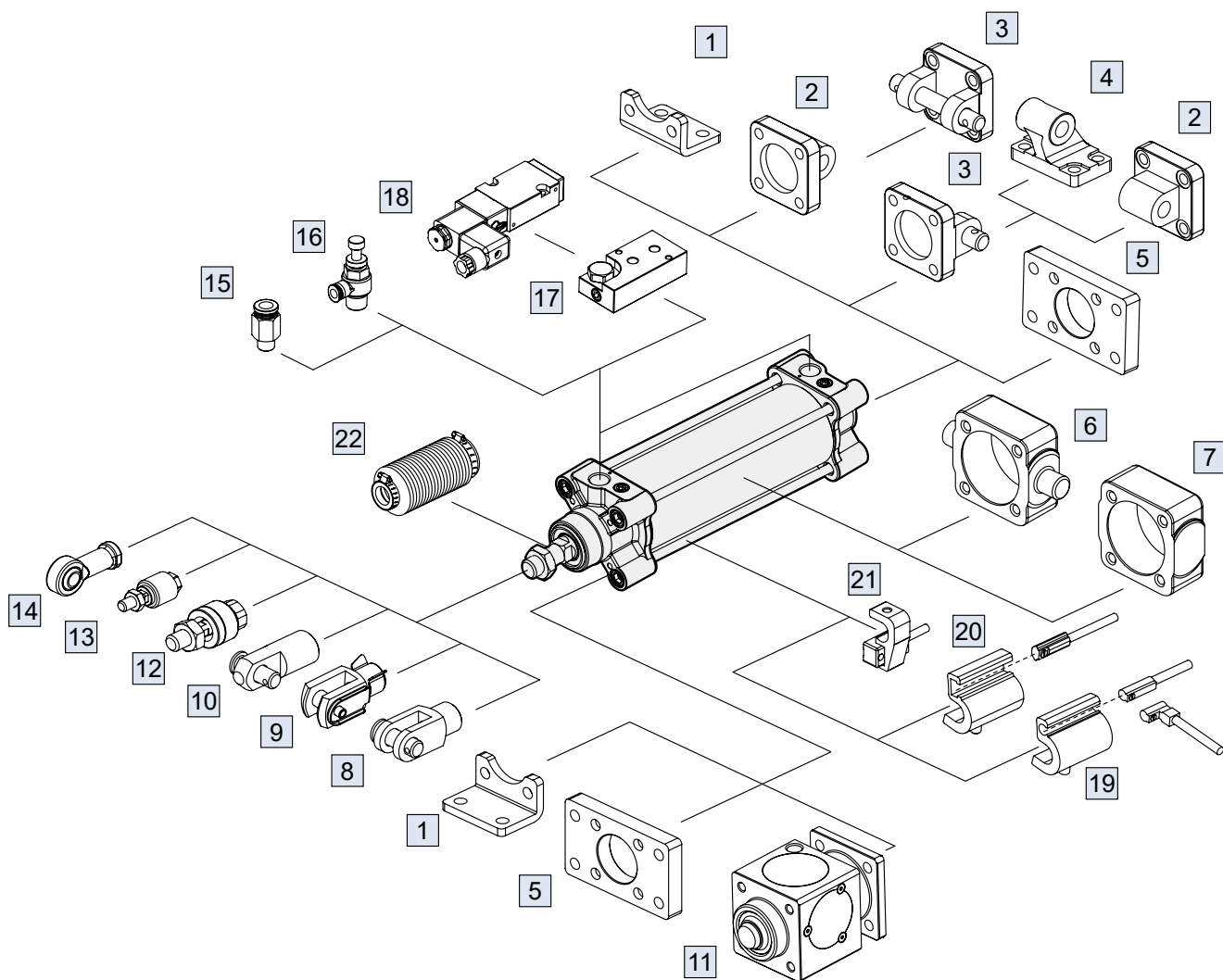

No.	Accessories	Material	Page link
1	Mounting accessories LB	Carbon steel	↗
2	Mounting accessories CA	Cast iron	↗
	Mounting accessories CA2	Aluminum alloy	↗
3	Mounting accessories CB+PIN	Cast iron / *1	↗ , ↗
	Mounting accessories CB2+PIN	Aluminum alloy	↗ , ↗
4	Mounting accessories CDB	Cast iron	↗
	Mounting accessories CDB2	Aluminum alloy	↗
5	Mounting accessories FAC/FBC	Carbon steel	↗
	Mounting accessories FAC2/FBC2	Aluminum alloy	↗
6	Mounting accessories TA/TB/TC	Cast iron	↗
7	Mounting accessories SDS	Cast iron	↗
8	Accessories Y+PIN	Cast iron / *1	↗
9	Accessories YS (Y+Floating pin)	Carbon steel	↗
10	Accessories I+PIN	Carbon steel	↗

No.	Accessories	Material	Page link
11	Locking unit MCBQV3	Aluminum alloy+*2	↗
12	Floating joint MFC	Carbon steel	↗
13	Floating joint MFCS	Carbon steel	↗
14	Female rod ends PHS	Carbon steel	↗
15	Fitting PC (PISCO)	—	↗
16	Speed controller JSC (PISCO)	—	↗
17	Cylinder link seats MVSN-300-C*3	Aluminum alloy	↗
18	Solenoid valve MVSN-220 / 300*3	—	↗ , ↗
19	Sensor switch R*C(V)+DT7.*	—	↗
20	Sensor switch R*T+DT.*	—	↗
21	Sensor switch RCA+HV*	—	↗
22	Protective bellows kit	NBR	—

*1. PIN material is carbon steel. *2. Bronze alloy.
*3. Only for tube I.D. $\varnothing 40$, $\varnothing 50$.

11

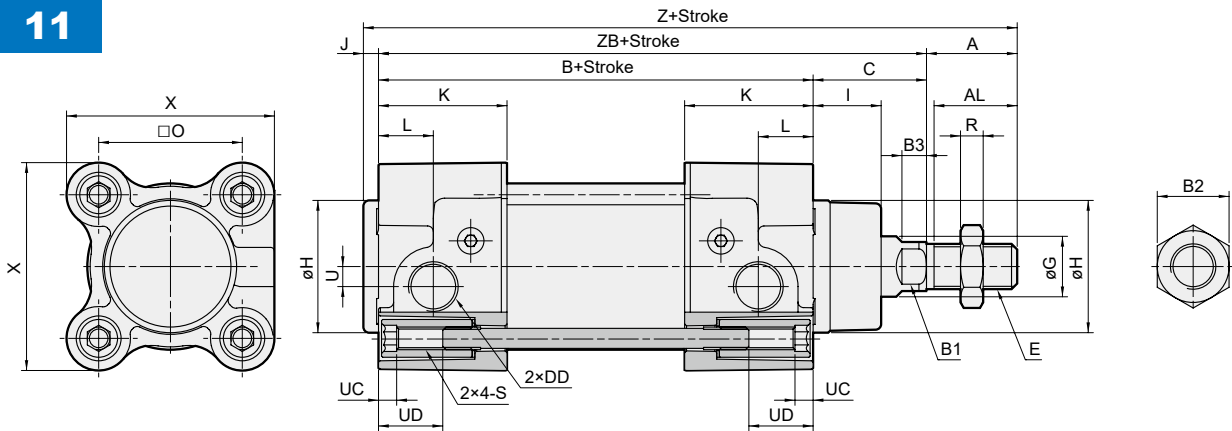

21

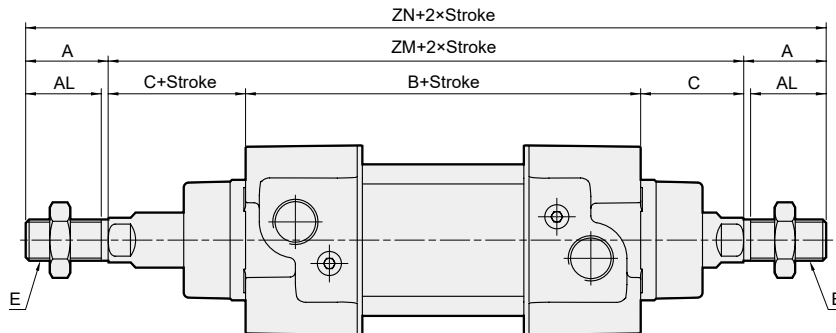

27

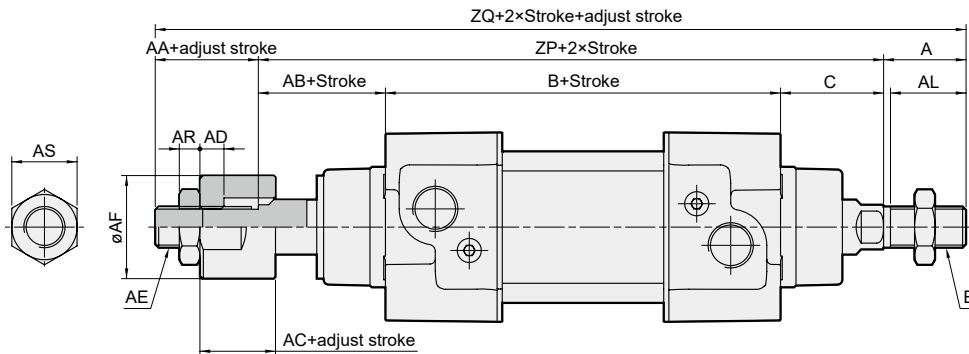

Code Tube I.D.	A	AA	AB	AC	AD	AE	AF	AL	AR	AS	B	B1	B2	B3	C	DD	E	G	H	I	J	K	L	O
32	22	16	26	12	7	M10×1.25	20	20	5	17	94	10	17	4	26	G1/8	M10×1.25	12	30	15	4	30.5	20	32.5
40	24	20	27	12	7	M12×1.25	30	22	6	19	105	13	19	6.5	30	G1/4	M12×1.25	16	35	18	4	34	14.5	38
50	32	18	34	15	10	M16×1.5	40	30	8	24	106	17	24	6	37	G1/4	M16×1.5	20	40	28	4	31	16	46.5
63	32	20	32	15	10	M16×1.5	40	30	8	24	121	17	24	8	37	G3/8	M16×1.5	20	45	26	4	33	17	56.5
80	40	32	41	20	14	M22×1.5	50	38	13	32	128	22	30	10	46	G3/8	M20×1.5	25	45	32.5	4	35.5	20.5	72
100	40	30	46	20	14	M22×1.5	50	38	13	32	138	22	30	10	51	G1/2	M20×1.5	25	55	37.5	4	37	19	89

Code Tube I.D.	R	S	U	UC	UD	X	Z	ZB	ZM	ZN	ZP	ZQ
32	5	M6×1.0	4.5	4.5	16	47	146	120	146	190	146	184
40	6	M6×1.0	5.3	4.5	16	55	163	135	165	213	162	206
50	8	M8×1.25	8.5	4.5	16	65	179	143	180	244	177	227
63	8	M8×1.25	8	4.5	16	78	194	158	195	259	190	242
80	10	M10×1.5	9	4.5	18	95	218	174	220	300	215	287
100	10	M10×1.5	13	4.5	18	115	233	189	240	320	235	305

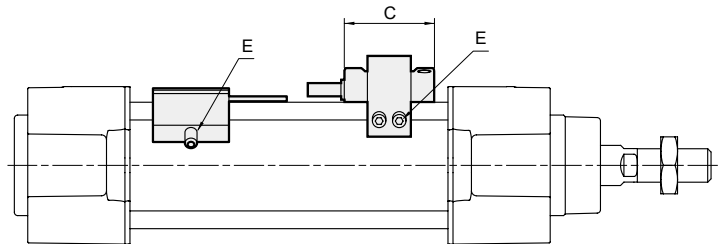
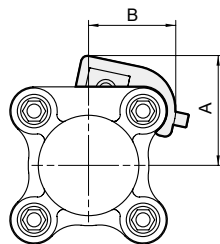
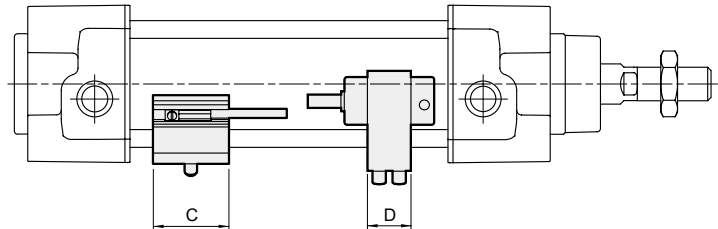
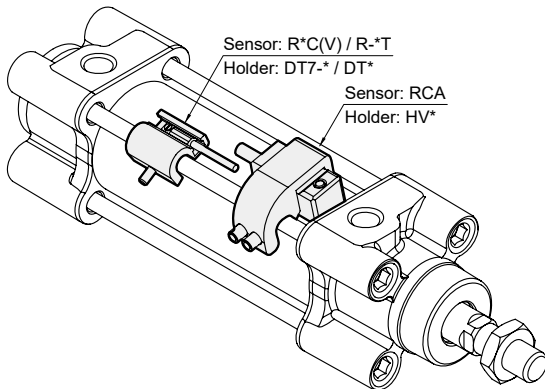

Code Tube I.D.	Sensor switch	Holder	A	B	C	E
32	R*C(V) / R*T	DT7-1 / DT-1	24	26	25	M4×12L
40	R*C(V) / R*T	DT7-1 / DT-1	28	29.5	25	M4×12L
50	R*C(V) / R*T	DT7-1 / DT-1	31.5	32	25	M4×12L
63	R*C(V) / R*T	DT7-1 / DT-1	36	37	25	M4×12L
80	R*C(V) / R*T	DT7-2 / DT-2	45	46	25	M4×12L
100	R*C(V) / R*T	DT7-2 / DT-2	53.5	55	25	M4×12L

Code Tube I.D.	Sensor switch	Hold	A	B	C	D	E
32	RCA	HV1	34	25	26	13	M4×10L
40	RCA	HV1	34	26	26	13	M4×10L
50	RCA	HV2	43	38	26	13	M4×10L
63	RCA	HV2	48	43	26	13	M4×10L
80	RCA	HV3	55	48	26	13	M5×16L
100	RCA	HV3	62	58	26	13	M5×16L

■ Mounting accessories

LB

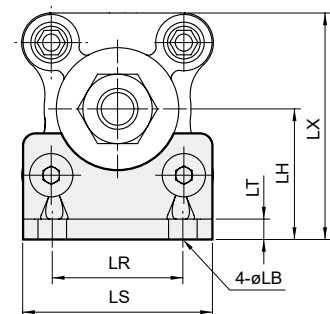
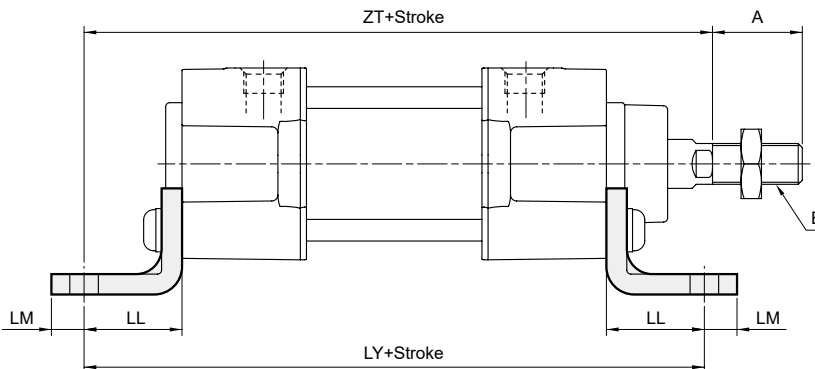

Code Tube I.D.	A	E	LB	LH	LL	LM	LR	LS	LT	LX	LY	ZT
32	22	M10×1.25	7	32	24	8	32	47	5	55.5	142	144
40	24	M12×1.25	9	36	28	10	36	53	5	63.2	161	163
50	32	M16×1.5	9	45	32	10	45	65	5	77.5	170	175
63	32	M16×1.5	9	50	32	10	50	75	5	89.0	185	190
80	40	M20×1.5	12	63	41	13	63	95	6	110.5	210	215
100	40	M20×1.5	14	71	41	13	75	115	6	128.5	220	230

FAC

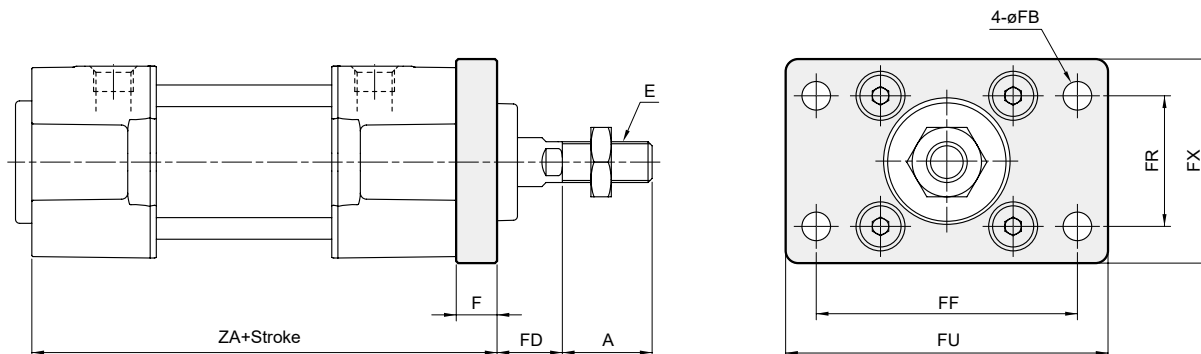

FBC

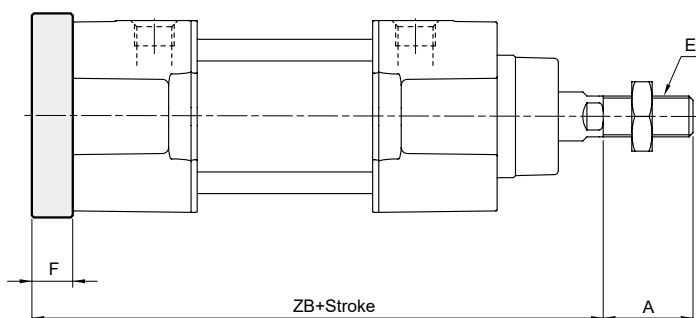

Code Tube I.D.	A	E	F	FB	FD	FF	FR	FU	FX	ZA	ZB
32	22	M10×1.25	10	7	16	64	32	79	50	104	130
40	24	M12×1.25	10	9	20	72	36	90	52	115	145
50	32	M16×1.5	12	9	25	90	45	110	65	118	155
63	32	M16×1.5	12	9	25	100	50	125	76	133	170
80	40	M20×1.5	16	12	30	126	63	154	94	144	190
100	40	M20×1.5	16	14	35	150	75	180	112	154	205

FAC2

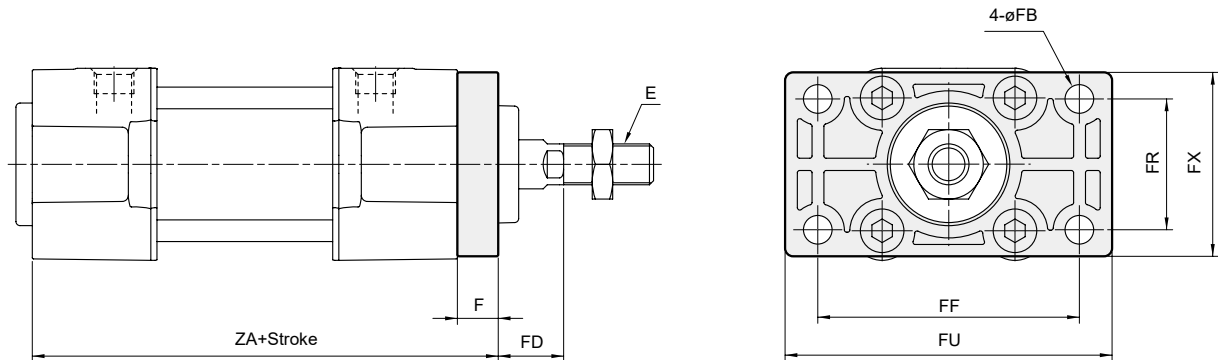

FBC2

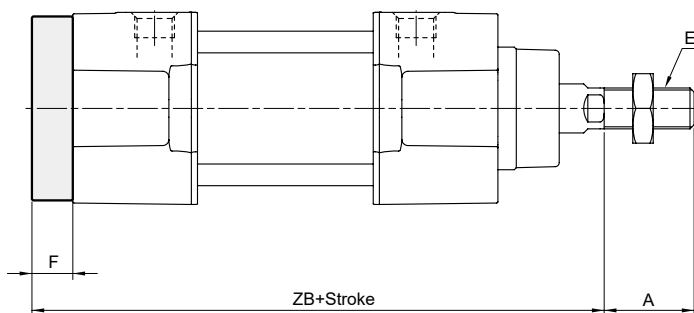

Code Tube I.D.	A	E	F	FB	FD	FF	FR	FU	FX	ZA	ZB
32	22	M10×1.25	10	7	16	64	32	80	45	104	130
40	24	M12×1.25	10	9	20	72	36	90	52	115	145
50	32	M16×1.5	12	9	25	90	45	110	65	118	155
63	32	M16×1.5	12	9	25	100	50	120	75	133	170
80	40	M20×1.5	16	12	30	126	63	150	95	144	190
100	40	M20×1.5	16	14	35	150	75	175	115	154	205

CA

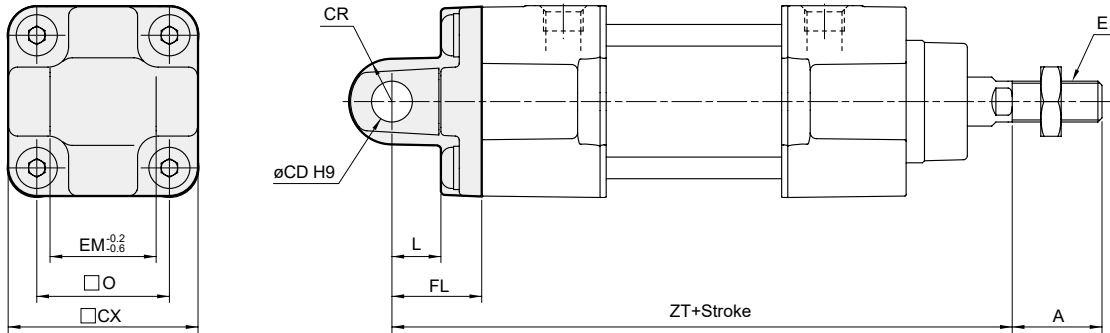

CB

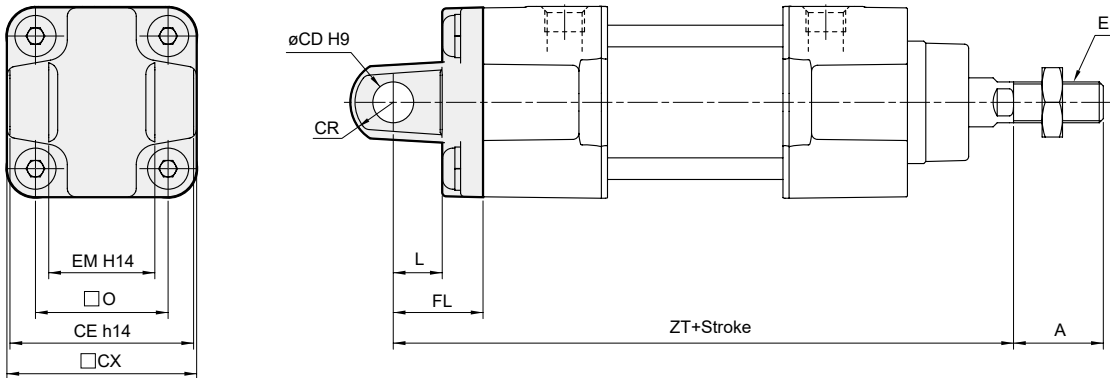

CDB

CB+Pin (Extra purchase)

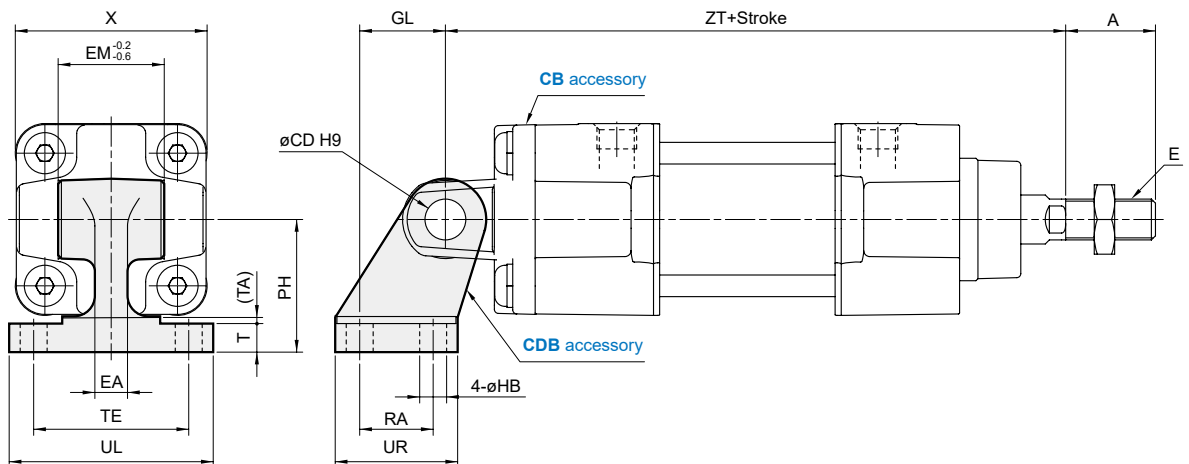

Code Tube I.D.	A	CD	CE	CR	CX	E	EA	EM	FL	GL	HB	L	O	PH	RA	T	TA	TE	UL	UR	X	ZT
32	22	10	45	R10.5	46.5	M10×1.25	8	26	22	21	6.6	12	32.5	32	18	6.5	1.5	38	50	30	47	142
40	24	12	52	R12	54	M12×1.25	10	28	25	24	6.6	15	38	36	22	8.5	1.5	41	53	34	55	160
50	32	12	60	R13	64	M16×1.5	10	32	27	33	9	15	46.5	45	30	10.5	1.5	50	65	45	65	170
63	32	16	70	R17	75	M16×1.5	12	40	32	37	9	20	56.5	50	35	10.5	1.5	52	67	50	78	190
80	40	16	90	R17	93	M20×1.5	12	50	36	47	11	20	72	63	40	11.5	2.5	66	86	60	95	210
100	40	20	110	R21	114	M20×1.5	16	60	41	55	11	25	89	71	50	12.5	2.5	76	96	70	115	230

CA2

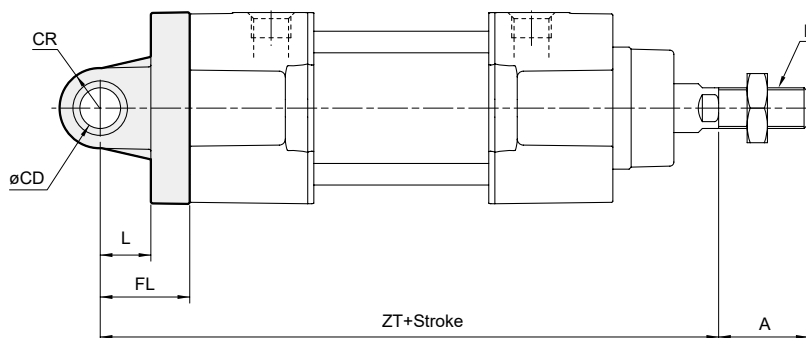
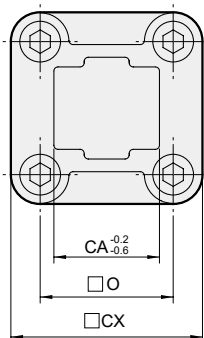

CB2

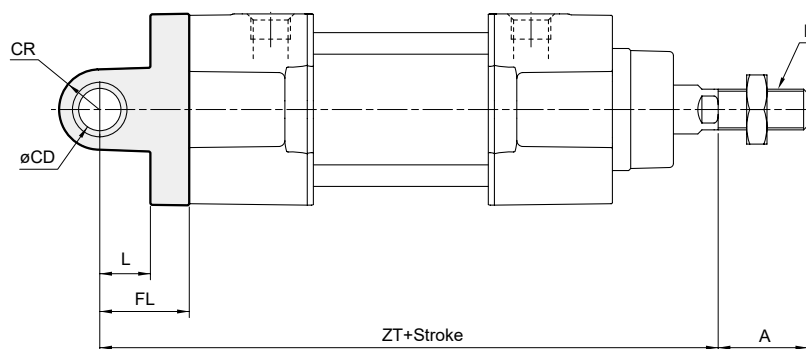
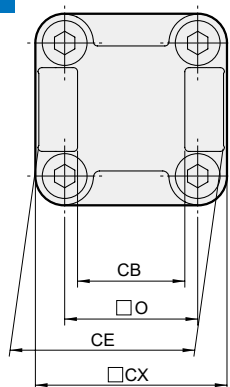

CDB2

CB2+Pin (Extra purchase)

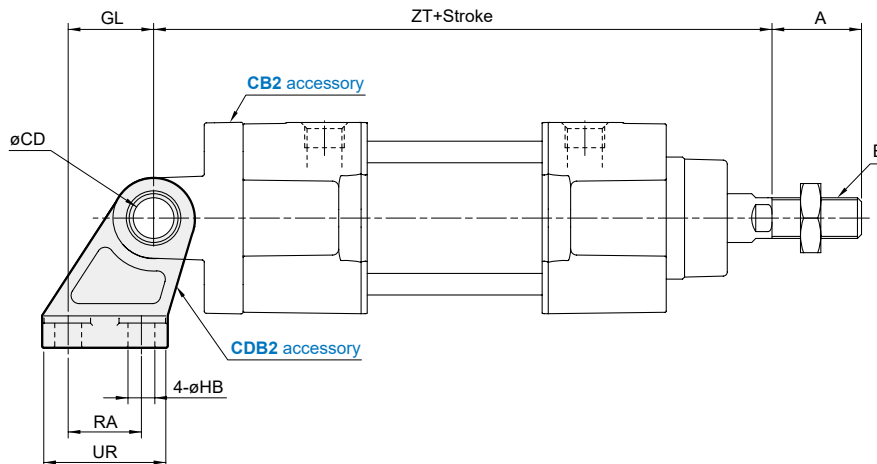
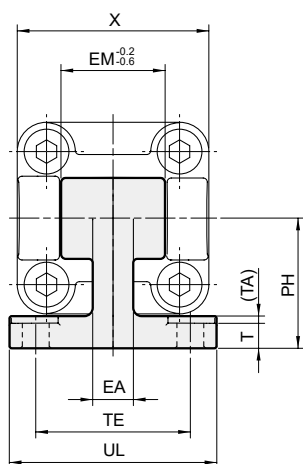

Code Tube I.D.	A	CA	CB ^{H14}	CD ^{H9}	CE ^{H14}	CR	CX	E	EA	EM	FL	GL	HB	L	O	PH	RA	T	TA	TE	UL	UR	X	ZT
32	22	26	26 ^{+0.052 0}	10 ^{+0.036 0}	45 ^{0 -0.62}	R10	47	M10×1.25	10	26	22	21	6.6	12.5	32.5	32	18	8	1.6	38	51	31	47	142
40	24	28	28 ^{+0.052 0}	12 ^{+0.043 0}	52 ^{0 -0.74}	R12	53	M12×1.25	15	28	25	24	6.6	16	38	36	22	10	1.6	41	54	35	55	160
50	32	32	32 ^{+0.062 0}	12 ^{+0.043 0}	60 ^{0 -0.74}	R12	65	M16×1.5	16	32	27	33	9	16	46.5	45	30	12	1.6	50	65	45	65	170
63	32	40	40 ^{+0.062 0}	16 ^{+0.043 0}	70 ^{0 -0.74}	R16	75	M16×1.5	16	40	32	37	9	21	56.5	50	35	14	1.6	52	67	50	78	190
80	40	50	50 ^{+0.062 0}	16 ^{+0.043 0}	90 ^{0 -0.87}	R16	95	M20×1.5	20	50	36	47	11	22	72	63	40	14	2.5	66	86	60	95	210
100	40	60	60 ^{+0.074 0}	20 ^{+0.052 0}	110 ^{0 -0.87}	R20	115	M20×1.5	20	60	41	55	11	27	89	71	50	17	2.5	76	96	70	115	230

TC

SDS

Mid section support
Stroke over 1000mm

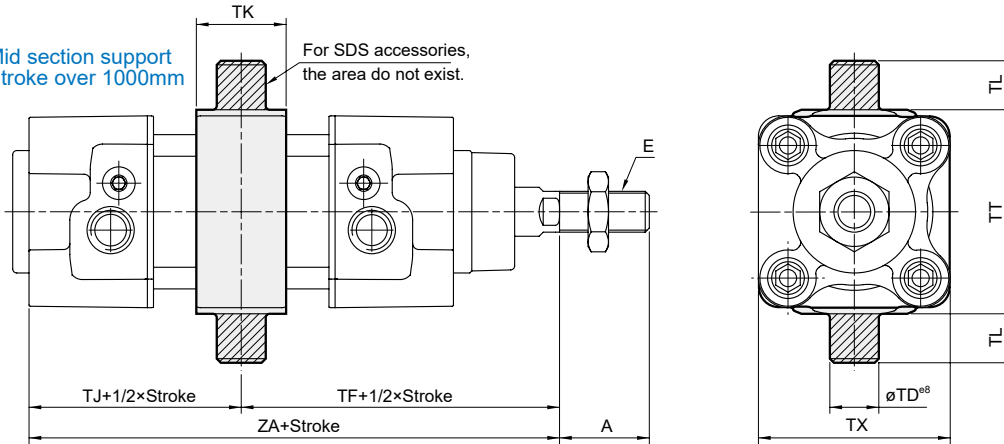

TA

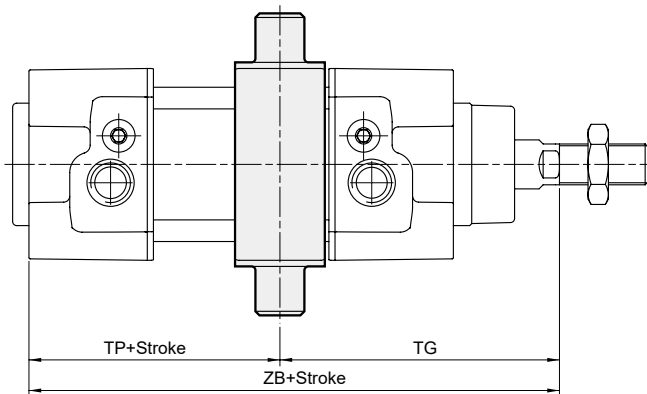

TB

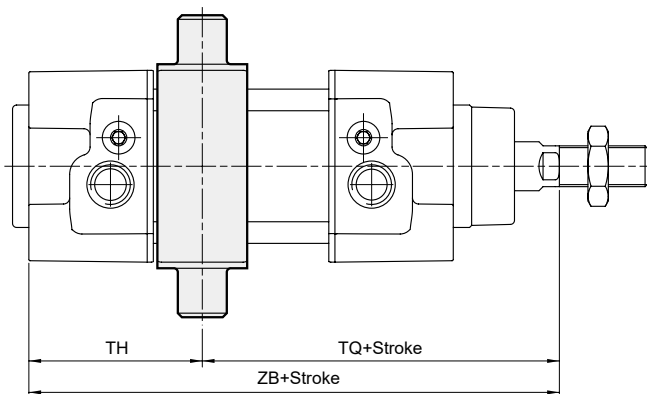

Code Tube I.D.	A	E	TD	TF	TG	TH	TJ	TK	TL	Without magnet			Magnet			TC	SDS	TX	ZA
										TP	TQ	ZB	TP	TQ	ZB				
32	22	M10×1.25	12	73	68.5	42.5	47	22	12	51.5	77.5	120	81.5	107.5	150	50	49	47	120
40	24	M12×1.25	16	82.5	76	46	52.5	22	16	59	89	135	89	119	165	63	55	53	135
50	32	M16×1.5	16	90	80	43	53	22	16	63	100	143	93	130	173	75	68	66	143
63	32	M16×1.5	20	97.5	85	48	60.5	28	20	73	110	158	103	140	188	90	82	80	158
80	40	M20×1.5	20	110	99.5	53.5	64	34	20	74.5	120.5	174	114.5	160.5	214	110	108	106	174
100	40	M20×1.5	25	120	109	58	69	40	25	80	131	189	120	171	229	132	130	126	189

Y connector

$\phi 32 \sim \phi 40$

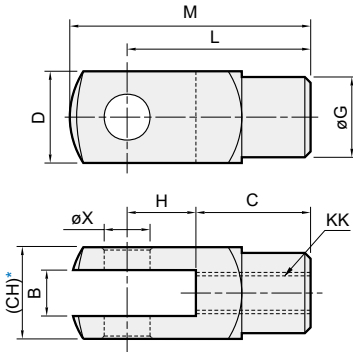

$\phi 50 \sim \phi 100$

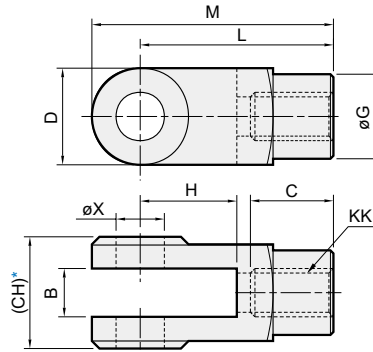

I connector

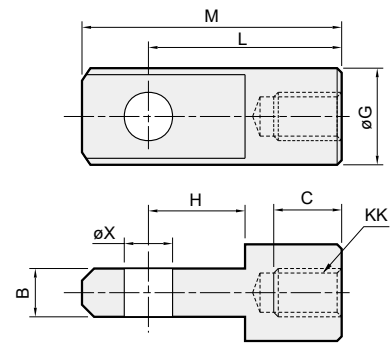

* Please do not take the sand casting plate as the mounting plate, because we do not machine it. If you have this special demand, please contact our sales representative.

Code Tube I.D.	B		C		CH		D		G		H		KK		L		M		X ^{H9}
	Y	I	Y	I	Y	I	Y	I	Y	I	Y	I	Y	I	Y	I	Y	I	
32	10 ^{+0.5} _{+0.15}	10 ^{-0.1} _{-0.2}	20	17	19	—	19	—	ø18	ø20	20	15	M10×1.25	40	40	52	52	ø10 ^{+0.04} ₀	
40	12 ^{+0.5} _{+0.15}	12 ^{-0.1} _{-0.2}	24	21	22	—	22	—	ø20	ø24	24	18	M12×1.25	48	48	62	62	ø12 ^{+0.04} ₀	
50	16 ^{+0.3} _{+0.1}	16 ^{-0.1} _{-0.3}	28	23	32	—	32	—	ø28	ø32	32	32	M16×1.5	64	64	89	86	ø16 ^{+0.04} ₀	
63	16 ^{+0.3} _{+0.1}	16 ^{-0.1} _{-0.3}	28	23	32	—	32	—	ø28	ø32	32	32	M16×1.5	64	64	89	86	ø16 ^{+0.04} ₀	
80	20 ^{+0.3} _{+0.1}	20 ^{-0.1} _{-0.3}	33	30	45	—	40	—	ø36	ø36	40	40	M20×1.5	80	80	100	108	ø20 ^{+0.05} ₀	
100	20 ^{+0.3} _{+0.1}	20 ^{-0.1} _{-0.3}	33	30	45	—	40	—	ø36	ø36	40	40	M20×1.5	80	80	100	108	ø20 ^{+0.05} ₀	

PIN

S

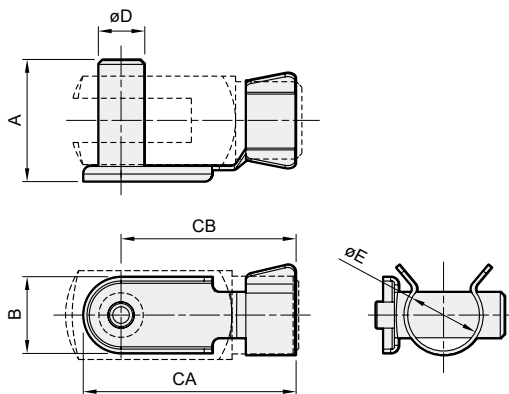

for floating pin

Code Tube I.D.	A	B	CA	CB	D ^{d9}	E
32	26	14	45	38	ø10 ^{-0.04} _{-0.07}	17
40	31	16	54	46	ø12 ^{-0.05} _{-0.09}	19
50,63	42	20	70	60	ø16 ^{-0.05} _{-0.09}	27
80,100	56	30	91	76	ø20 ^{-0.06} _{-0.11}	35

P

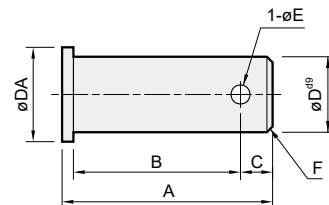

for Y & I connector

Code Tube I.D.	A	B	C	D ^{d9}	DA	E	F	Split pin
32	30	25	3.5	ø10 ^{-0.06} _{-0.09}	14	3.2	1	3.2×20L
40	37	30	5	ø12 ^{-0.06} _{-0.09}	16	3.2	1	3.2×20L
50,63	47	37	7	ø16 ^{-0.05} _{-0.09}	22	4	1	4×25L
80,100	62	50	8	ø20 ^{-0.06} _{-0.11}	30	5	1.5	5×35L

P

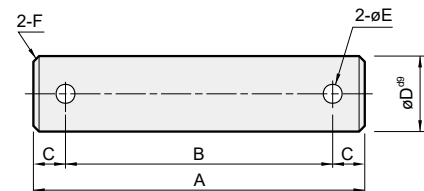

for CA & CB

Code Tube I.D.	A	B	C	D ^{d9}	E	F	Split pin
32	69	55	7	ø10 ^{-0.05} _{-0.09}	4	1.0	4×20L
40	76	62	7	ø12 ^{-0.05} _{-0.09}	4	1.0	4×20L
50	84	70	7	ø12 ^{-0.05} _{-0.09}	4	1.0	4×20L
63	94	80	7	ø16 ^{-0.05} _{-0.09}	4	1.0	4×30L
80	117	100	8.5	ø16 ^{-0.05} _{-0.09}	5	1.5	5×30L
100	137	120	8.5	ø20 ^{-0.05} _{-0.09}	5	1.5	5×35L

MCQV3 Solenoid valve link seats $\varnothing 40, \varnothing 50$



ISO 15552 **STANDARD CYLINDER**

mindman

Order example

MCQV3 — As standard order example — VR — 4E2C — 6A — AC110 — L

MODEL

SOLENOID VALVE LINK SEATS
 VR: Installed on the front cover
 VH: Installed on the back cover

4 way (5 port)

E1: Single solenoid
E2: Double solenoid

C: Closed center
P: Pressure center
R: Exhaust center
 (Only for MVSN-300-4E2)

PORT SIZE
6A: G1/8
 (Only for MVSN-220)
8A: G1/4

VOLTAGE
AC220V(50/60)Hz
AC110V(50/60)Hz
DC24V

* MCQV3- $\varnothing 40$ (for MVSN-220 valve)

* MCQV3- $\varnothing 50$ (for MVSN-300 valve)

ELECTRIC CONNECTION

Standard	
Blank	DIN terminal
L	DIN terminal with LED indicator
E	Explosion protection
Power saving (for DC24V)	
KL	DIN terminal with LED indicator

MVSN-300-C Solenoid valve link seats

Solenoid valve link seats

Mounting of solenoid valve link seats

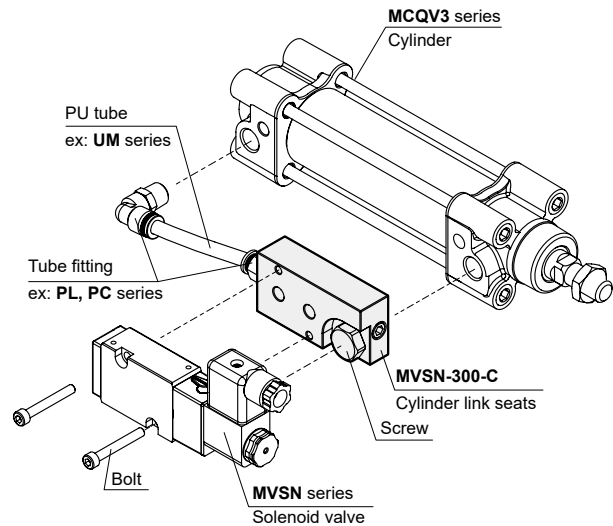
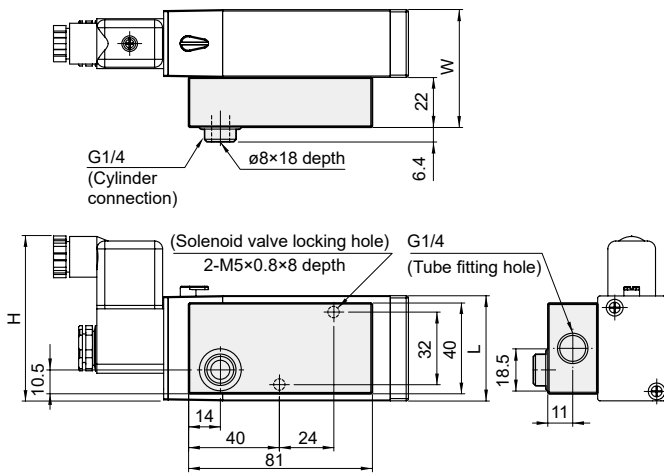

Code Model	H	W	L	Cylinder type
MVSN-220	70	44.3	40	MCQV3/MCQI3 $\varnothing 40$
MVSN-300	73	52	46.4	MCQV3/MCQI3 $\varnothing 50$



Technical data



Caution for safety
(Read before installing)

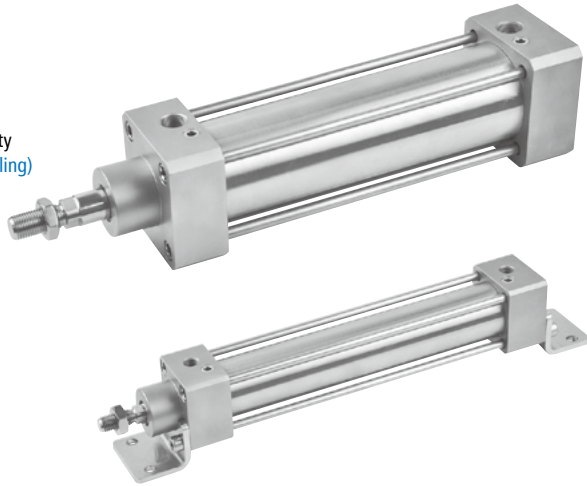

Feature

- **High strength steel & chemical resistance**

Made of AISI 316 stainless steel.

- **ISO 15552 standard specification**

Conform to ISO 15552 specification, enabling worldwide interchangeability.

- **Cylinder mountings**

Available with comprehensive internationally recognised range of fixed and flexible mountings.

- **Magnetic as standard**

Specification

Model	MCQVS		
Tube I.D. (mm)	32,40	50,63	80,100
Medium	Air		
Operating pressure range	0.1~1 MPa		
Proof pressure	1.5 MPa		
Ambient temperature	-10~+80°C (No freezing)		
Available speed range	50~1000 mm/sec		
Sensor switch	RCV 		
Sensor switch band	BV125		

Table for standard stroke

Tube I.D.	Stroke (mm)	Max. stroke (mm)
ø32~ø100	25,50,75,100,125,150,175,200,250,300,350,400,450,500,600,700,800,900	1000

* Intermediate stroke are available, please contact us.

* Made to order.

Order example

MCQVS - 11 - 40 - 100M

MODEL

1: Single rod
2: Double rod



TUBE I.D.

STROKE

M: Magnet

* Magnetic as standard.

STYLE

Code	Symbol	Description	Max adjustable stroke
1 1		Double acting / Male thread	-
2 1		Double rod / Male thread	
2 7		Double rod / Adjustable male thread Please mark "adjustable stroke" at order list	200 mm

MCQVS-11 Inside structure & Parts list

ISO 15552 **STANDARD CYLINDER (STAINLESS STEEL)**



Single rod 11 type

ø32, ø40

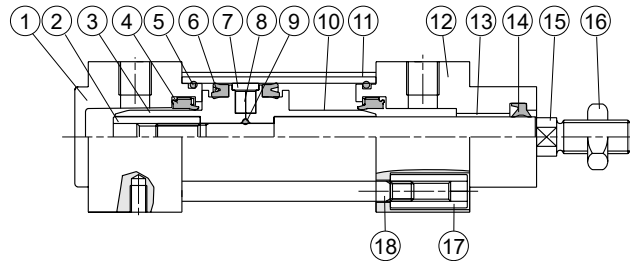
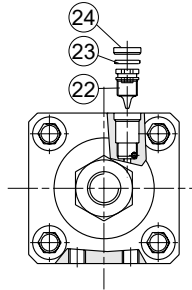

ø50~ø100

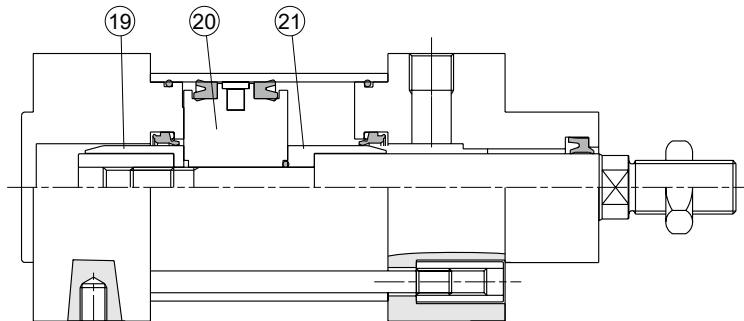
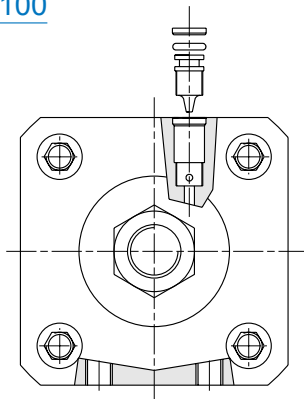

No.	Part name	Material	Q'y	Component parts (inclusion)		Repair kits (inclusion)	Note
				ø30, ø40	ø50~ø100		
1	Head cover	SUS316	1	●	●		
2	Piston nut	Carboon steel	1	●	●		
3	Piston-H	Aluminum alloy	1	●			
4	Cushion packing	NBR	2	●	●	●	
5	O-ring	NBR	2	●	●	●	
6	Piston packing	NBR	2	●	●	●	
7	Wear ring	Resin	1	●	●		
8	Magnet ring	Magnet material	1 or 2	◎	◎	◎	ø32,40 (Q'y 2) ◎ Option
9	O-ring	NBR	1	●	●	●	
10	Piston-R	Aluminum alloy	1	●			
11	Cylinder tube	SUS316	1				
12	Rod cover	SUS316	1	●	●		
13	Bush	Resin	1	●	●		
14	Rod packing	NBR	1	●	●	●	
15	Piston rod	SUS316	1				
16	Hex nut	SUS316	1	●	●		
17	Tie rod nut	SUS316	8	●	●		
18	Tie rod	SUS316	4				
19	Cushioning rod - H	Aluminum alloy	1		●		
20	Piston	Aluminum alloy	1		●		
21	Cushioning rod - R	Aluminum alloy	1		●		
22	Needle valve	SUS316	2	●	●		
23	O-ring	NBR	2	●	●	●	
24	Needle valve washer	SUS316	2	●	●		

MCQVS-2* Inside structure & Parts list

ISO 1552 **STANDARD CYLINDER** (STAINLESS STEEL)



Double rod 21 / 27 type

ø32, ø40

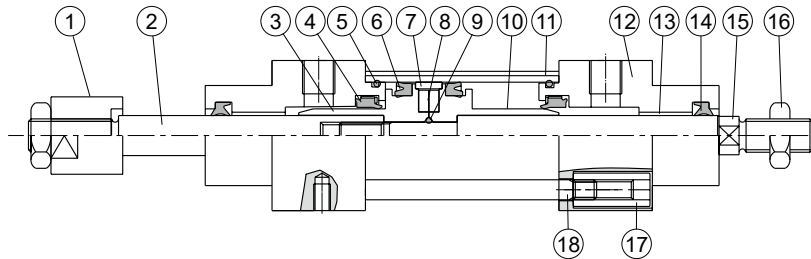
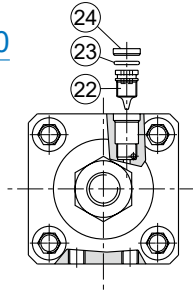

ø50~ø100

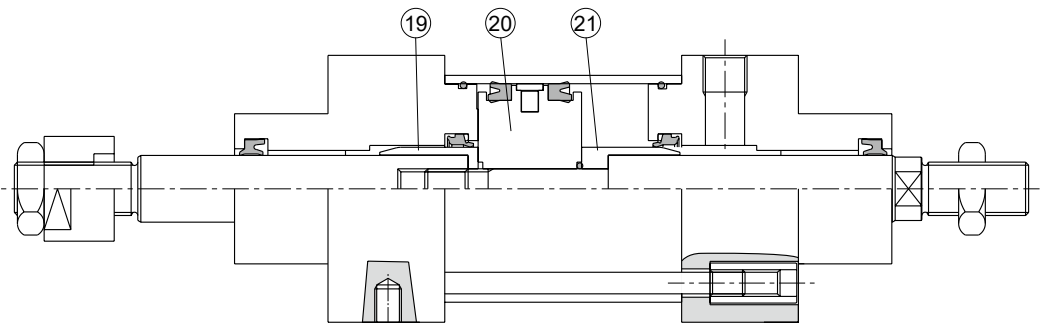
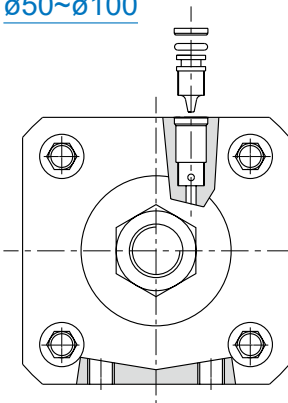

No.	21 type		27 type		Part name	Material	Q'y	Component parts (inclusion)		Repair kits (inclusion)	Note
	A	B	A	B				ø32, ø40	ø50~ø100		
1			●	●	Adjustable nut	SUS316	1				
2	●	●	●	●	Piston rod #2	SUS316	1				
3	●		●		Piston-H	Aluminum alloy	1	●			
4	●	●	●	●	Cushion packing	NBR	2	●	●	●	
5	●	●	●	●	O-ring	NBR	2	●	●	●	
6	●	●	●	●	Piston packing	NBR	2	●	●	●	
7	●	●	●	●	Wear ring	Resin	1	●	●		
8	●	●	●	●	Magnet ring	Magnet material	1 or 2	◎	◎	◎	ø32,40 (Q'y 2) ◎ Option
9	●	●	●	●	O-ring	NBR	1	●	●	●	
10	●		●		Piston-R	Aluminum alloy	1	●			
11	●	●	●	●	Cylinder tube	SUS316	1				
12	●	●	●	●	Rod cover	SUS316	2	●	●		
13	●	●	●	●	Bush	Resin	2	●	●		
14	●	●	●	●	Rod packing	NBR	2	●	●	●	
15	●	●	●	●	Piston rod #1	SUS316	1				
16	●	●	●	●	Hex nut	SUS316	2	●	●		
17	●	●	●	●	Tie rod nut	SUS316	8	●	●		
18	●	●	●	●	Tie rod	SUS316	4				
19		●		●	Cushioning rod - H	Aluminum alloy	1		●		
20		●		●	Piston	Aluminum alloy	1		●		
21		●		●	Cushioning rod - R	Aluminum alloy	1		●		
22	●	●	●	●	Needle valve	SUS316	2	●	●		
23	●	●	●	●	O-ring	NBR	2	●	●	●	
24	●	●	●	●	Needle valve washer	SUS316	2	●	●		

A: ø32, ø40, B: ø50~ø100

Order example of component parts

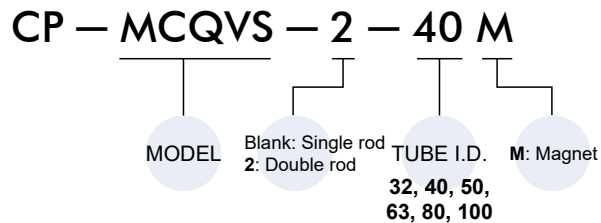

Order example of repair kits

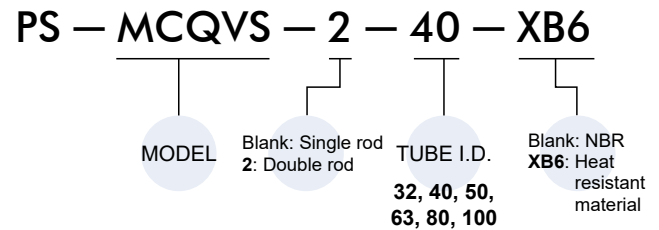

Cylinder & accessories weight

Cylinder weight

Unit: kg

Model	Basic weight MCQVS-11	Basic weight (magnet) MCQVS-11	Stroke 25 mm MCQVS-11	Basic weight MCQVS-21	Basic weight (magnet) MCQVS-21	Stroke 25 mm MCQVS-21
Tube I.D.						
$\varnothing 32$	1.061	1.067	0.088	1.184	1.19	0.108
$\varnothing 40$	1.797	1.809	0.128	2.008	2.02	0.165
$\varnothing 50$	2.597	2.614	0.180	2.953	2.97	0.243
$\varnothing 63$	4.389	4.409	0.200	4.770	4.79	0.263
$\varnothing 80$	6.750	6.777	0.310	7.425	7.45	0.413
$\varnothing 100$	11.227	11.262	0.350	12.033	12.07	0.443

Style 27	Cylinder (A)			Adjustable nut (B)	
Model	Basic weight MCQVS-27	Basic weight (magnet) MCQVS-27	Stroke 25 mm MCQVS-27	Basic weight MCQVS-27	Adjustable stroke 25 mm MCQVS-27
Tube I.D.					
$\varnothing 32$	1.166	1.170	0.108	0.037	0.039
$\varnothing 40$	1.982	1.989	0.166	0.109	0.097
$\varnothing 50$	2.883	2.893	0.242	0.150	0.183
$\varnothing 63$	4.704	4.714	0.262	0.150	0.183
$\varnothing 80$	7.279	7.295	0.405	0.388	0.201
$\varnothing 100$	11.895	11.913	0.442	0.407	0.201

* Total weight of style 27 = A + B

Accessories weight

Unit: kg

Model	LB	CA	CB	CDB	FAC/FBC	TC	YP	Pin CA / CB
Tube I.D.								
$\varnothing 32$	0.060	0.176	0.138	0.158	0.192	0.128	0.090	0.032
$\varnothing 40$	0.072	0.274	0.230	0.238	0.250	0.308	0.153	0.052
$\varnothing 50$	0.160	0.368	0.338	0.418	0.482	0.370	0.317	0.060
$\varnothing 63$	0.180	0.682	0.540	0.526	0.626	0.690	0.317	0.122
$\varnothing 80$	0.370	1.196	1.000	1.055	1.436	0.894	0.680	0.152
$\varnothing 100$	0.432	2.100	1.700	1.510	1.994	1.584	0.680	0.290

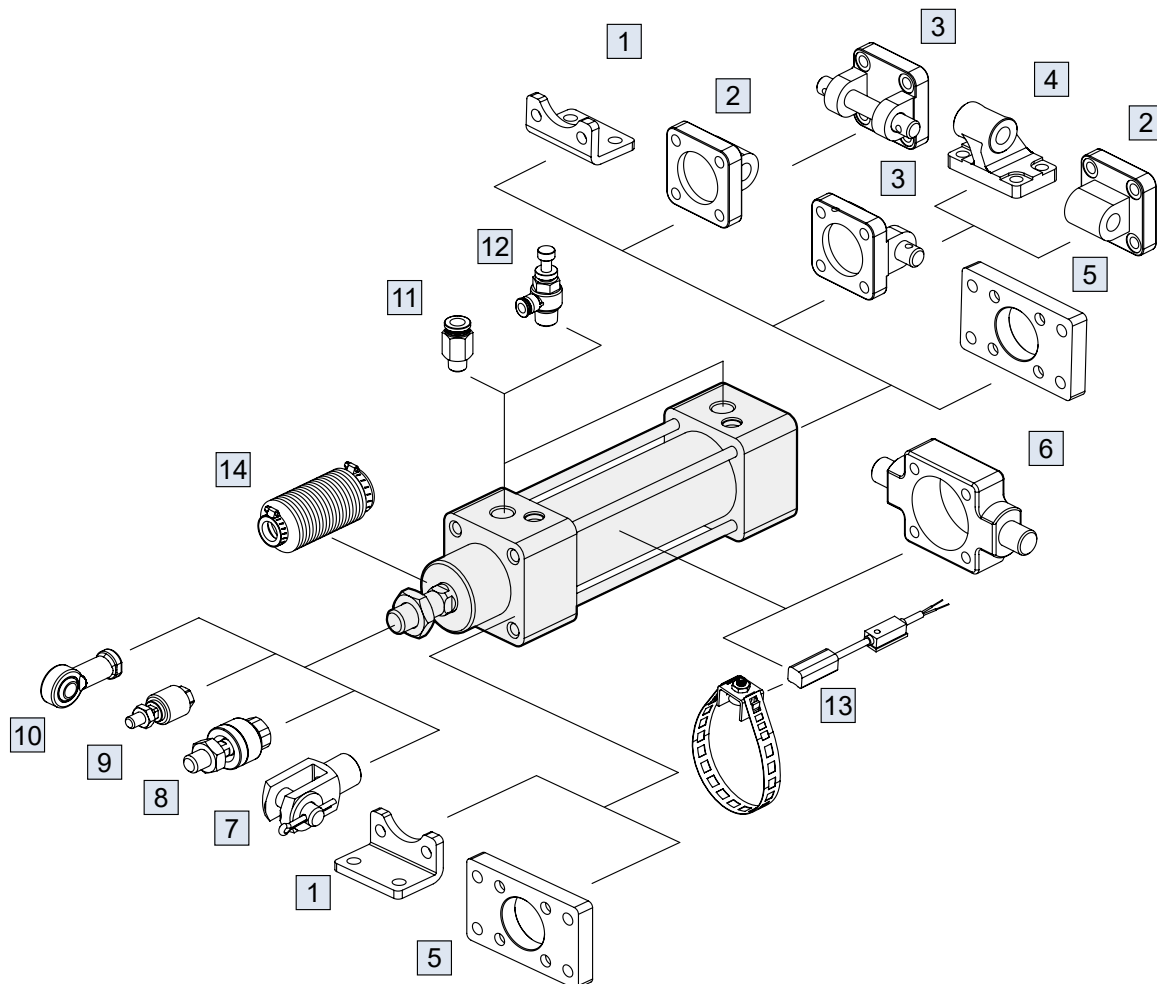

No.	Accessories	Material	Page link
1	Mounting accessories LB	SUS316	↗
2	Mounting accessories CA	SUS316	↗
3	Mounting accessories CB+PIN	SUS316	↗ , ↗
4	Mounting accessories CDB	SUS316	↗
5	Mounting accessories FAC/FBC	SUS316	↗
6	Mounting accessories TC	SUS316	↗
7	Accessories YP (Y+PIN)	SUS316	↗

No.	Accessories	Material	Page link
8	Floating joint MFC	Carbon steel	↗
9	Floating joint MFCS	Carbon steel	↗
10	Female rod ends PHS-S	SUS	↗
11	Fitting PC (PISCO)	—	↗
12	Speed controller JSC (PISCO)	—	↗
13	Sensor switch RCV+BV125	—	↗
14	Protective bellows kit	NBR	—

11

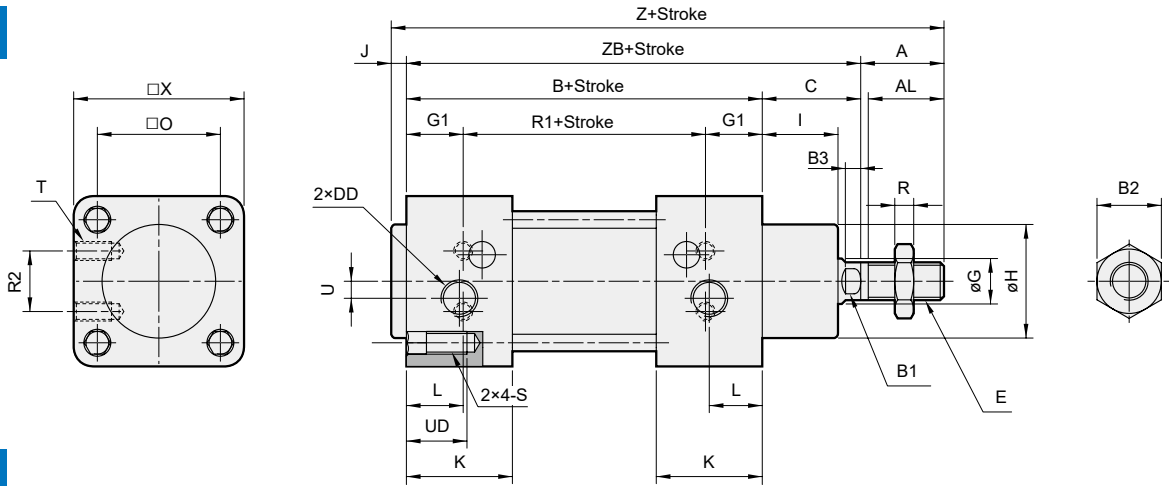

21

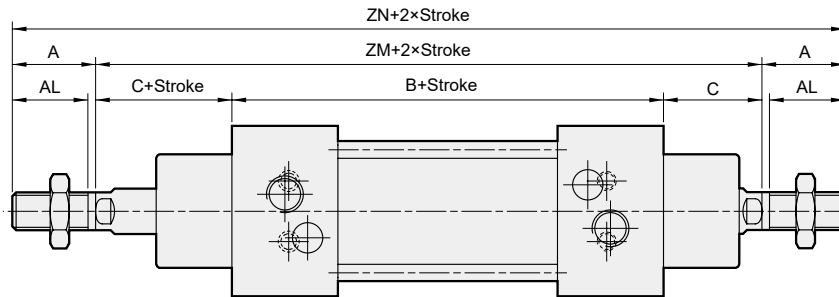

27

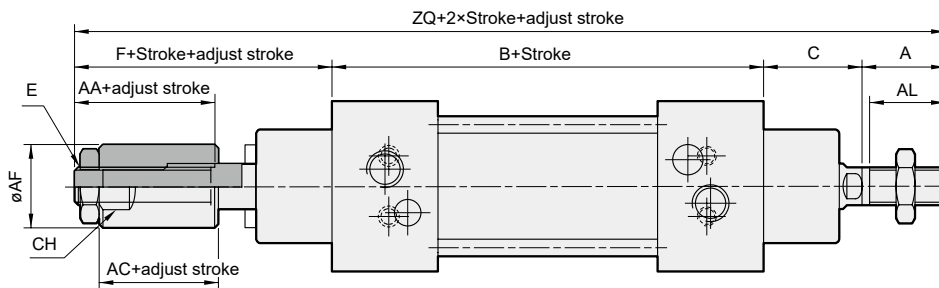

Code Tube I.D.	A	AA	AC	AF	AL	B	B1	B2	B3	C	CH	DD	E	F	G	G1	H	I	J	K	L	O	R	R1	R2
32	22	28	20	20	20	94	10	17	4	26	17	G1/8	M10×1.25	48	12	15	30	20	4	28	14	32.5	6	64	16
40	24	30.5	24	30	22	105	13	19	6	30	27	G1/4	M12×1.25	54	16	17.5	35	22	4	31.5	16	38	7	70	21
50	32	28	19	40	30	106	17	24	5.5	37	36	G1/4	M16×1.5	59	20	16	40	28	4	31.5	21	46.5	8	74	24
63	32	28	19	40	30	121	17	24	5.5	37	36	G3/8	M16×1.5	59	20	18	45	28	4	35	22	56.5	8	85	33
80	40	45	32	50	37	128	22	30	9	46	46	G3/8	M20×1.5	81	25	18	45	34	4	36	23	72	9	92	34
100	40	45	35	50	37	138	22	30	9	51	46	G1/2	M20×1.5	86	25	19	55	38	4	41	26	89	9	100	58

Code Tube I.D.	S	T	U	UD	X	Z	ZB	ZM	ZN	ZQ
32	M6×1.0	M5×0.8×10L	4.5	16	45	146	120	146	190	190
40	M6×1.0	M6×1.0×10L	5.5	16	55	163	135	165	213	213
50	M8×1.25	M8×1.25×12L	8.5	16	65	179	143	180	244	234
63	M8×1.25	M8×1.25×12L	8.5	16	80	194	158	195	259	249
80	M10×1.5	M10×1.5×15L	8.5	16	95	218	174	220	300	295
100	M10×1.5	M10×1.5×15L	10	16	115	233	189	240	320	315

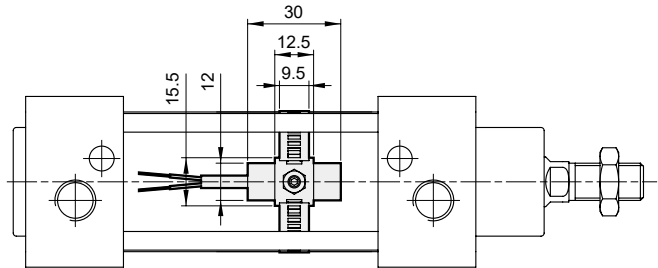
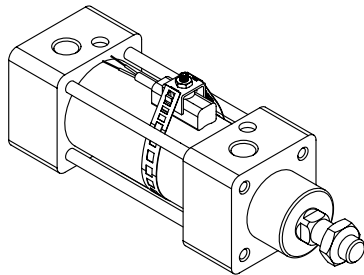

Code Tube I.D.	Sensor switch	A
32	RCV + BV125 (Band)	41
40		46
50		50
63		52
80		65
100		75

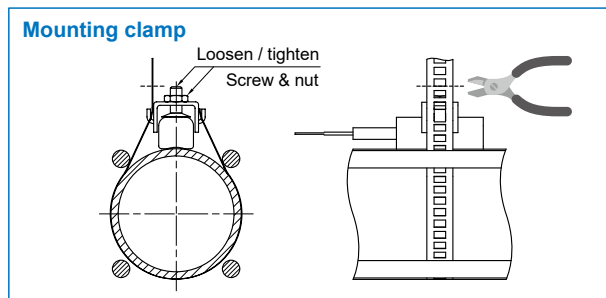
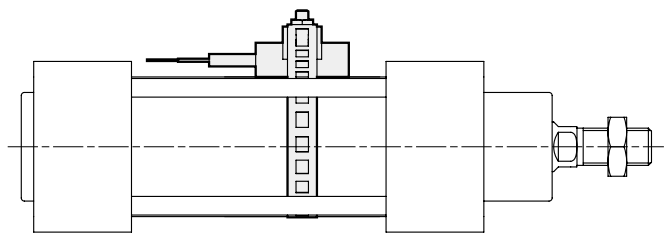
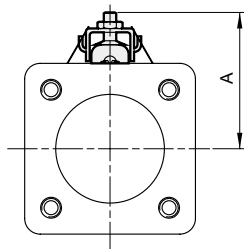

Mounting accessories

CDB CB+Pin (Extra purchase)

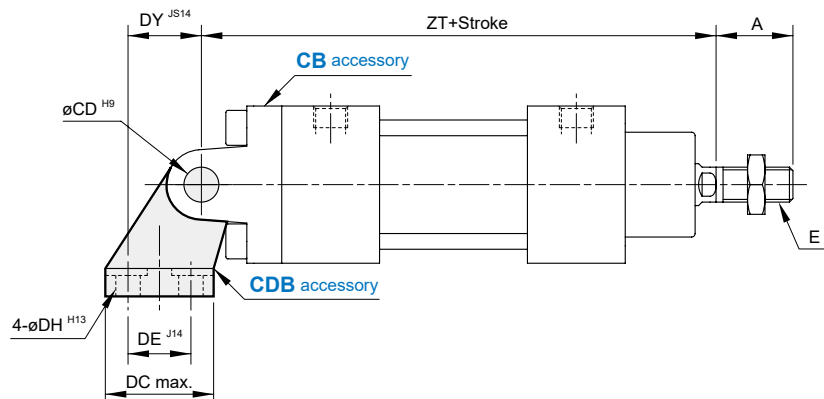
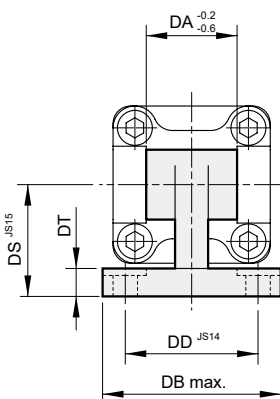

Code Tube I.D.	A	CD	DA	DB	DC	DD	DE	DH	DS	DT	DY	E	ZT
32	22	10	26	51	31	38	18	6.6	32	8	21	M10×1.25	142
40	24	12	28	54	35	41	22	6.6	36	10	24	M12×1.25	160
50	32	12	32	65	45	50	30	9	45	12	33	M16×1.5	170
63	32	16	40	67	50	52	35	9	50	12	37	M16×1.5	190
80	40	16	50	86	60	66	40	11	63	14	47	M20×1.5	210
100	40	20	60	96	70	76	50	11	71	17	55	M20×1.5	230

LB

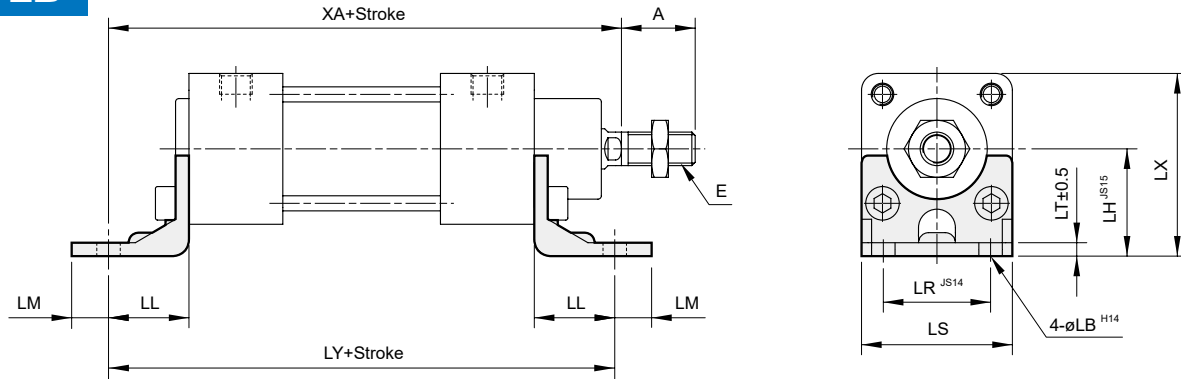

CA

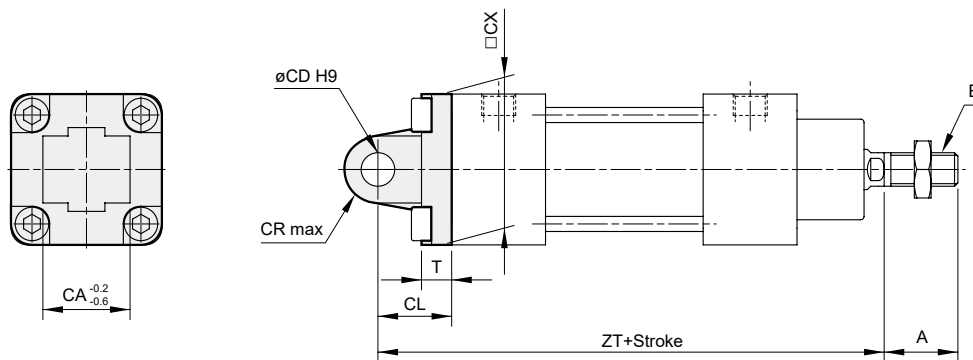

CB

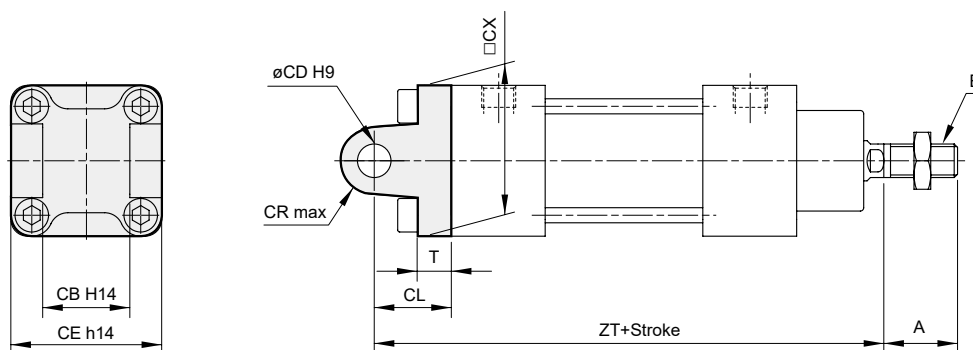

Code Tube I.D.	A	CA	CB	CD	CE	CL	CR	CX	E	LB	LH	LL	LM	LR	LS	LT	LX	LY	T	XA	ZT
32	22	26	26	10	45	22	10	45	M10×1.25	7	32	24	11	32	45	4	54.5	142	10	144	142
40	24	28	28	12	52	25	12	55	M12×1.25	9	36	28	8	36	52	4	63.5	161	10	163	160
50	32	32	32	12	60	27	12	65	M16×1.5	9	45	32	15	45	65	5	77.5	170	10	175	170
63	32	40	40	16	70	32	16	75	M16×1.5	9	50	32	13	50	75	5	90	185	12	190	190
80	40	50	50	16	90	36	16	95	M20×1.5	12	63	41	14	63	95	6	110.5	210	14	215	210
100	40	60	60	20	110	41	20	115	M20×1.5	14	71	41	16	75	115	6	128.5	220	16	230	230

TC

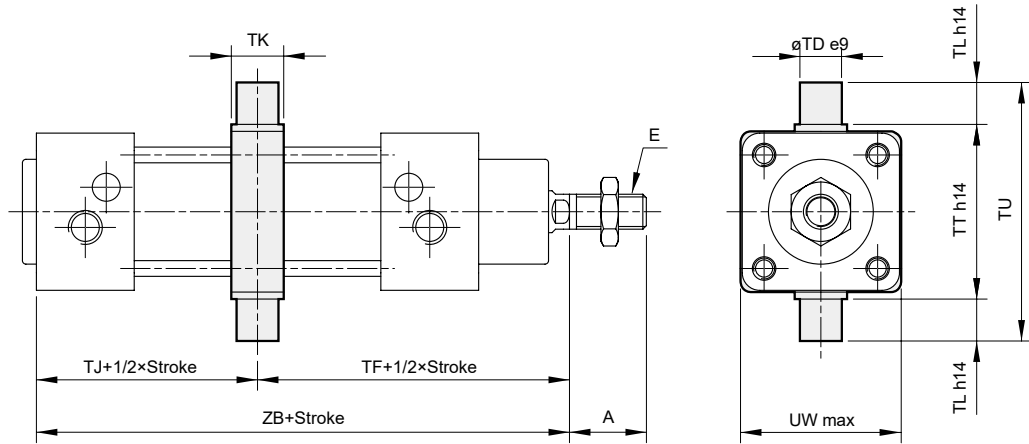

Code Tube I.D.	A	E	TD	TF	TJ	TK	TL	TT	TU	UW	ZB
32	22	M10×1.25	12	73	47	15	12	50	74	46	120
40	24	M12×1.25	16	82.5	53	20	16	63	95	59	135
50	32	M16×1.5	16	90	53	20	16	75	107	69	143
63	32	M16×1.5	20	98	61	25	20	90	130	84	158
80	40	M20×1.5	20	110	64	25	20	110	150	102	174
100	40	M20×1.5	25	120	69	30	25	132	182	125	189

FAC

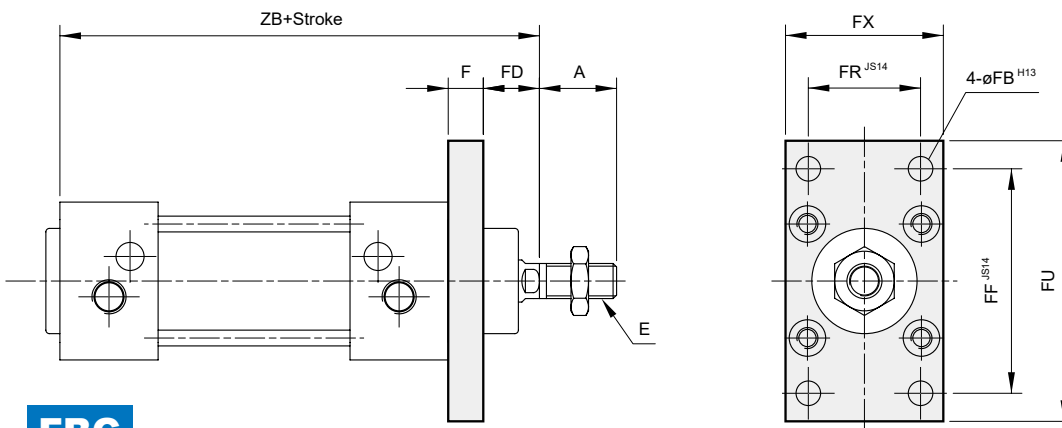

FBC

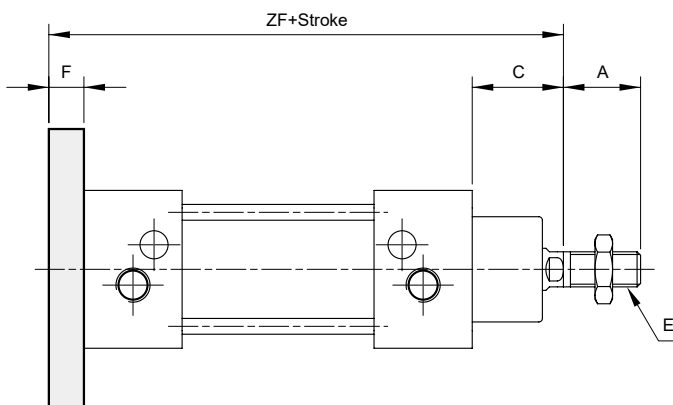

Code Tube I.D.	A	C	E	F	FB	FD	FF	FR	FU	FX	ZB	ZF
32	22	26	M10×1.25	10	7	16	64	32	80	45	120	130
40	24	30	M12×1.25	10	9	20	72	36	90	52	135	145
50	32	37	M16×1.5	12	9	25	90	45	110	65	143	155
63	32	37	M16×1.5	12	9	25	100	50	120	75	158	170
80	40	46	M20×1.5	16	12	30	126	63	150	95	174	190
100	40	51	M20×1.5	16	14	35	150	75	170	115	189	205

YP connector

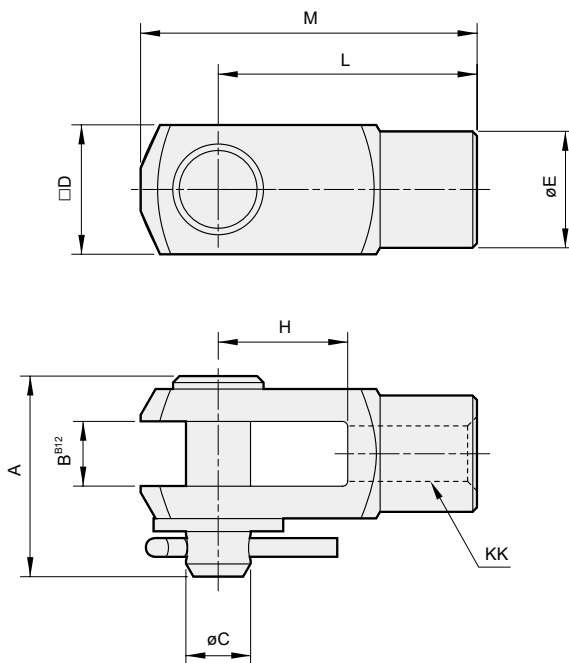

Code Tube I.D.	A	B	C	D	E	H	L	M	KK
32	31	10	10	20	18	20	40	52	M10×1.25
40	38	12	12	24	20	24	48	62	M12×1.25
50	49	16	16	32	26	32	64	83	M16×1.5
63	49	16	16	32	26	32	64	83	M16×1.5
80	57.5	20	20	40	34	40	80	105	M20×1.5
100	57.5	20	20	40	34	40	80	105	M20×1.5

PIN

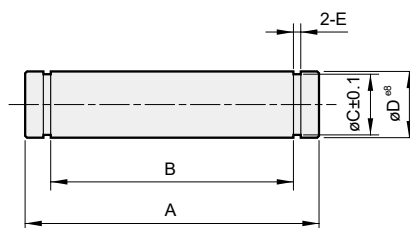

for CA & CB

Code Tube I.D.	A	B	C	D	E	Snap ring
32	51	46	9.6	10	1.1	A10
40	59	53	11.5	12	1.1	A12
50	66.5	61	11.5	12	1.1	A12
63	77	71	15.2	16	1.1	A16
80	97	91	15.2	16	1.1	A16
100	120	111	19	20	1.3	A20



Technical data



Caution for safety
(Read before installing)

R: Rod cover

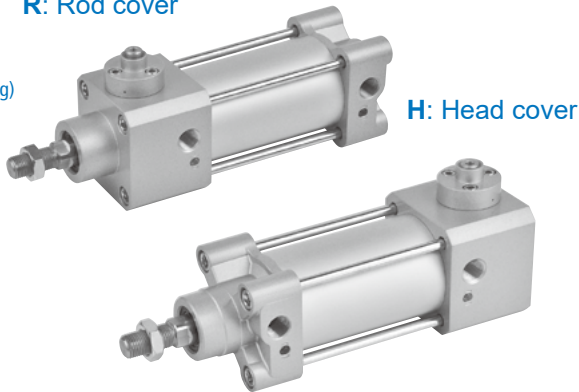

H: Head cover

Table for standard stroke

Tube I.D.	Stroke (mm)
ø63,80	50, 75, 100, 125, 150, 175, 200, 250, 300, 350, 400, 450, 500, 600

* Please contact us if the stroke is out of specification.

Order example

MCQV3L – 11 – 63 – 100M – R – T

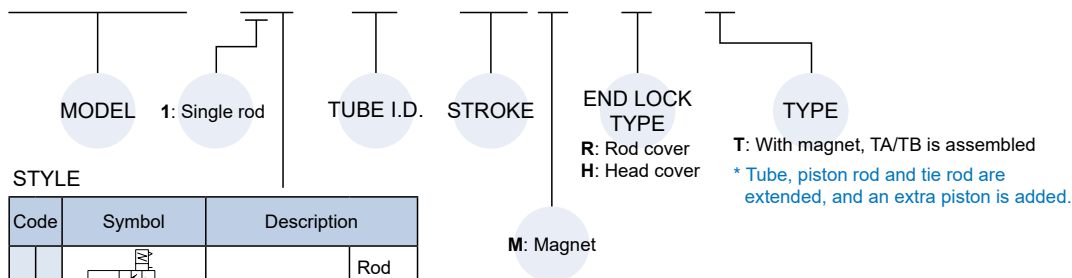

STYLE

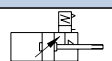
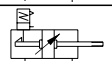
Code	Symbol	Description
1 1		Double acting / Male thread Rod cover
		Double acting / Male thread Head cover

* Rc or NPT thread are also available, please contact us.

Features

■ Non lubrication

Special housing and bushing enables self lubrication of piston rod.



■ High quality long service life

Hard anodised aluminium cylinder tubes offer a high resistance to corrosion and low internal friction.

■ ISO 15552 standard specification



Conforms to ISO 15552 specification enabling worldwide interchangeability.

Specification

Model	MCQV3L		
Tube I.D. (mm)	63	80	
Medium	Air		
Operating pressure range	0.15~1 MPa		
Proof pressure	1.5 MPa		
Ambient temperature	-5~+60°C (No freezing)		
Available speed range	50~500 mm/sec		
Holding force	Max. 2710 N	Max. 3690 N	
Backlash	1mm or less		
Sensor switch	RDC(V), RQC(V)  , RDT, RQT  , RCA 		
Sensor switch holder	R*C(V)	DT7-1	DT7-2
	R*T	DT-1	DT-2
	RCA	HV2	HV3

Cylinder weight

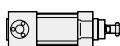
Unit: kg

Model		Basic weight MCQV3L-11	Basic weight (magnet) MCQV3L-11	Stroke 25 mm MCQV3L-11
Tube I.D.	End lock type			
ø63	R	2.42	2.45	0.13
	H	2.48	2.51	0.13
ø80	R	4.08	4.13	0.2
	H	4.14	4.19	0.2

* Accessories weight please refer to MCQV3 series .

END LOCK CYLINDER

Use recommended air pressure circuit

- The circuit layout must be settled properly. The recommended circuit design is shown below.

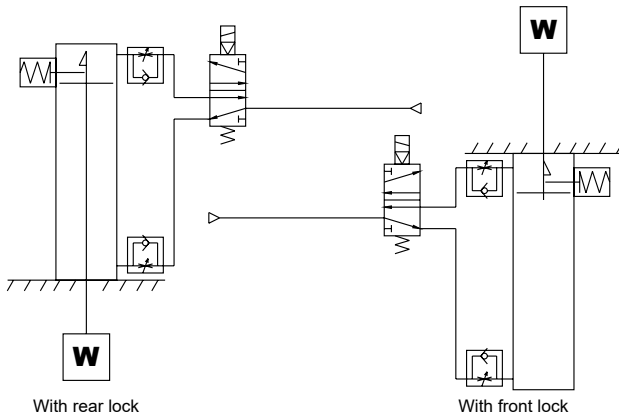

Maintains the cylinder's original position even if the air supply is interrupted.

Prevention of dropping at the rising end

With rear lock

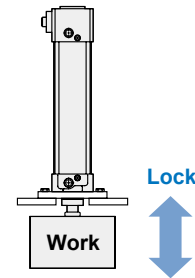

Locking of door With front lock

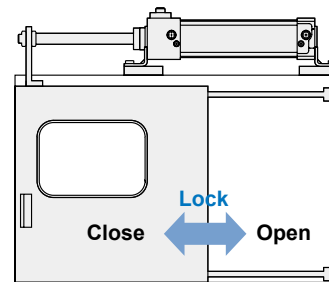

Precautions

- Do not use 3-way solenoid valves. The cylinder cannot be locked when compressed air is trapped in the lock side port. And the lock may be released due to the air leakage of solenoid valve, even it was locked successfully.
- Do not adjust or mount the cylinder when the lock is on.
- The operation load do not exceed 50% of the cylinder maximum output.
- Do not operate a workpiece with multiple end-lock cylinders simultaneously.
- Use an one-way speed control valve with meter-out circuit layout design. The lock cannot be released when the circuit layout is meter-in design.
- Operate the lock only when the cylinder is at the either end-position of stroke.
- The air supply must be higher than 0.15 MPa to operate the lock.
- The lock will be on when automatically when the pressure of the lock is lower than 0.1 MPa or less.
- There are many conditions that will cause the exhaust speed to reduce. The examples are shown below.
 - When the exhausting route length is too long.
 - When the one-way speed control valve is too far from cylinder port.
 - When the silencer of the solenoid valve is blocked or clogged.
- When the cushion needle is fully closed, the piston rod may not be able to reach the end of its stroke. When the cushion needle is fully closed and the cylinder is locked, the lock may not be able to be released.

END LOCK CYLINDER

Manual Lock Releasing

- 1 Install a bolt into the locking rod and pull it up by hands. When your hands release, the locking rod will move back by spring force and continue locking.

The bolt size, inner spring pulling force and the stroke of locking rod are listed below.

MODEL	Thread size	Pulling force	Stroke (mm)
MCQV3L-63	M6×1.0×20 L	24.5 N	4
MCQV3L-80	M6×1.0×20 L	24.5 N	5

- 2 The bolt must be uninstalled after manual lock releasing, or the weight of bolt may cause some performance problems of the lock.

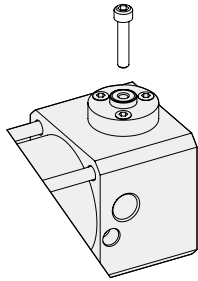

Installation of sensor switch

Sensor: R*C(V) / R*T
Holder: DT7-* / DT*
Sensor: RCA
Holder: HV*

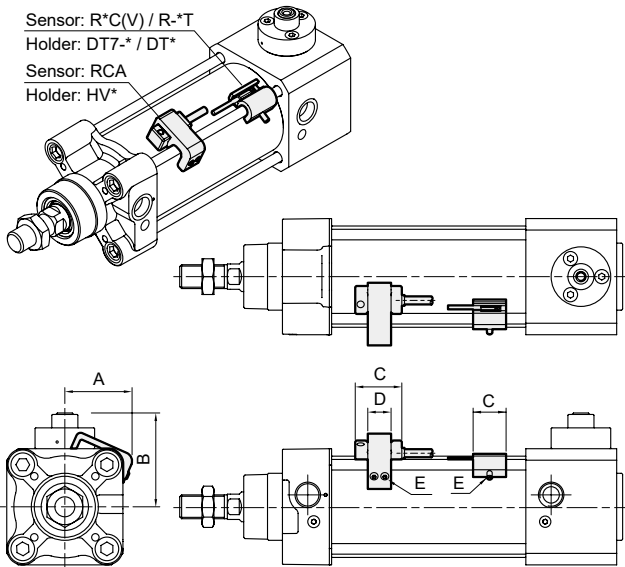

Code Tube I.D.	Sensor switch	Holder	A	B	C	D	E
63	R*C(V)	DT7-1	37	50	25	-	M4×12L
	R*T	DT-1					
	RCA	HV2	42.5	50	26	13	M4×10L
80	R*C(V)	DT7-2	46.5	60	25	-	M4×12L
	R*T	DT-2					
	RCA	HV3	49.5	60	26	13	M4×10L

Working Principle

- Both front locking type and rear locking type have the same mechanism. The pictures below shows that how a rear locking type cylinder works.

- 1 When the air pressure is input from front cap, the piston will move backward. After the piston nears the end of the stroke, the slope of chamfered rod (the position of *mark) will touch the locking rod.

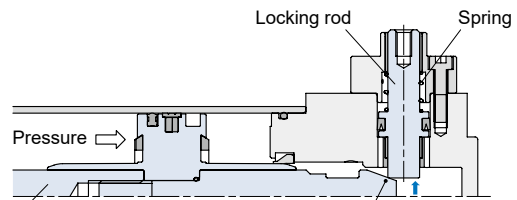

- 2 The locking rod will be guided with the slope and keeps moving upward.

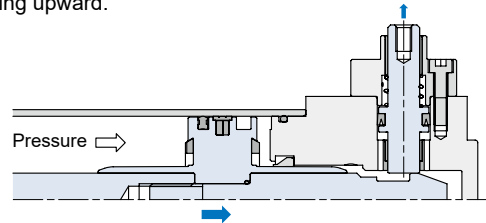

- 3 The locking rod will be pushed into the locking slot of the piston rod by the spring force. At this time, the cylinder is locked.

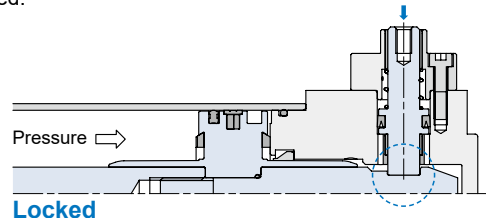

- 4 When the air pressure is input from rear cap, the piston will start moving forward. At the same time, the locking rod will be pushed up by the compressed air and make the piston rod unlocked.

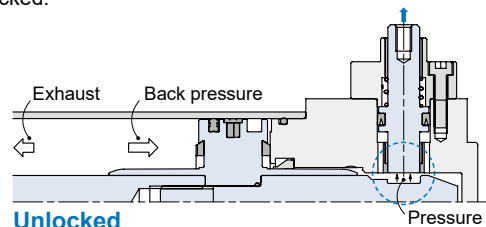

- 5 As the locking rod is no longer locking the piston rod, the cylinder can move forward.

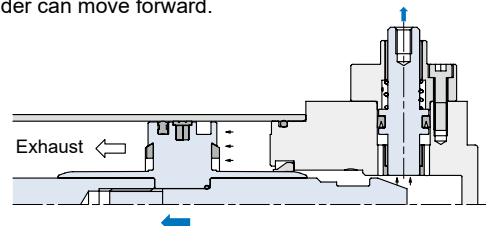

MCQV3L Inside structure & Parts list



END LOCK CYLINDER

mindman

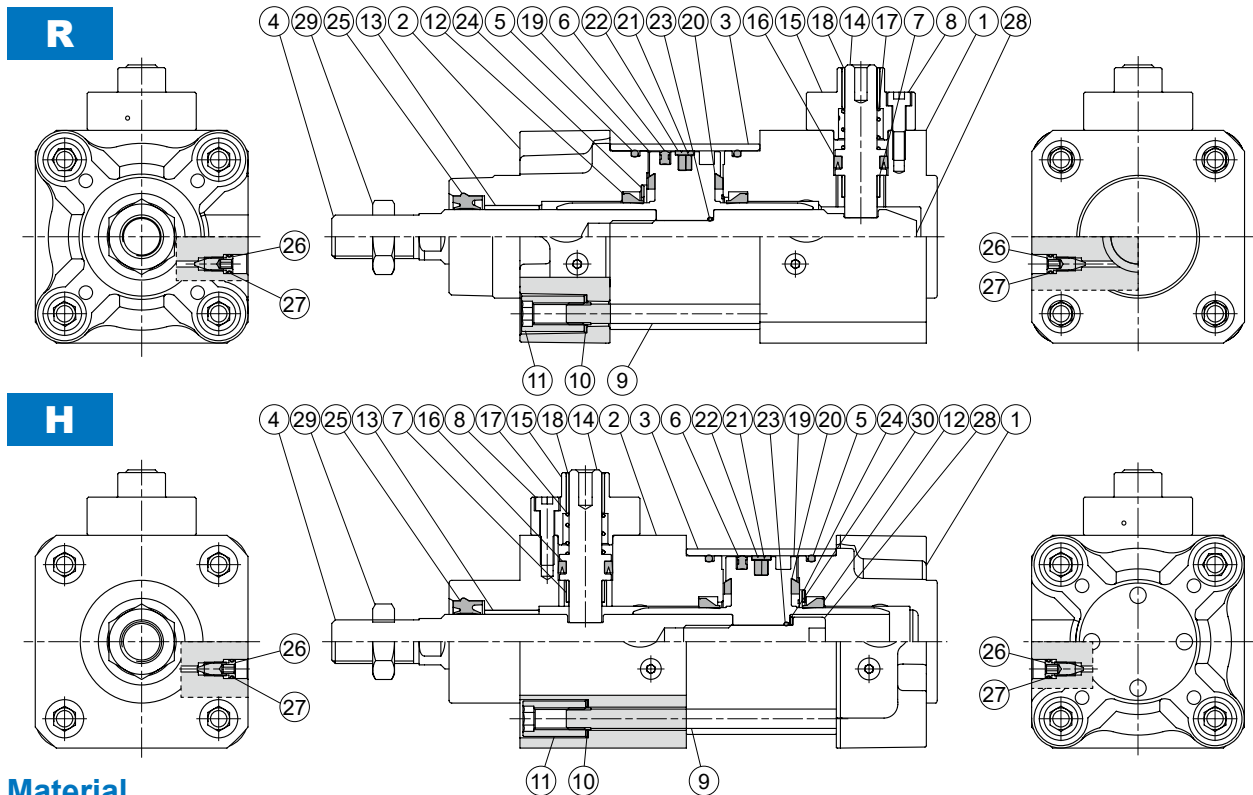

Material

No.	Part name	Material	Q'y	Repair kits (inclusion)
1	Head cover	Aluminum alloy	1	
2	Rod cover	Aluminum alloy	1	
3	Cylinder tube	Aluminum alloy	1	
4	Piston rod	Carbon steel	1	
5	O-ring	NBR	2	●
6	Piston packing	NBR	1	●
7	Bush	Bearing alloy	1	
8	Hex bolt	Carbon steel	3	
9	Tie rod	Carbon steel	4	
10	Washer	Carbon steel	8	
11	Tie rod nut	Carbon steel	8	
12	Cushion packing	NBR	2	●
13	Bush	Bearing alloy	1	
14	Locking rod	Carbon steel	1	
15	Fixing holder	Aluminum alloy	1	
16	Piston ring	NBR	1	●
17	Single action spring	Stainless steel	1	
18	Guide rod bushing	Copper alloy	1	
19	Piston	Aluminum alloy	1	
20	Cushion pad	NBR	2	
21	Magnet ring	Magnet material	1	
22	Wear ring	Resin	1	
23	O-ring	NBR	1	●
24	Washer	Carbon steel	1	
25	Rod packing	NBR	1	
26	Needle valve	Copper alloy	1	
27	O-ring	NBR	2	●
28	Piston nut	Carbon steel	2	
29	Piston rod nut	Carbon steel	1	
30	Cushion pad	NBR	1	

Repair kits

Tube I.D.	Repair kits
ø63	PS-MCQV3L-63
ø80	PS-MCQV3L-80

R

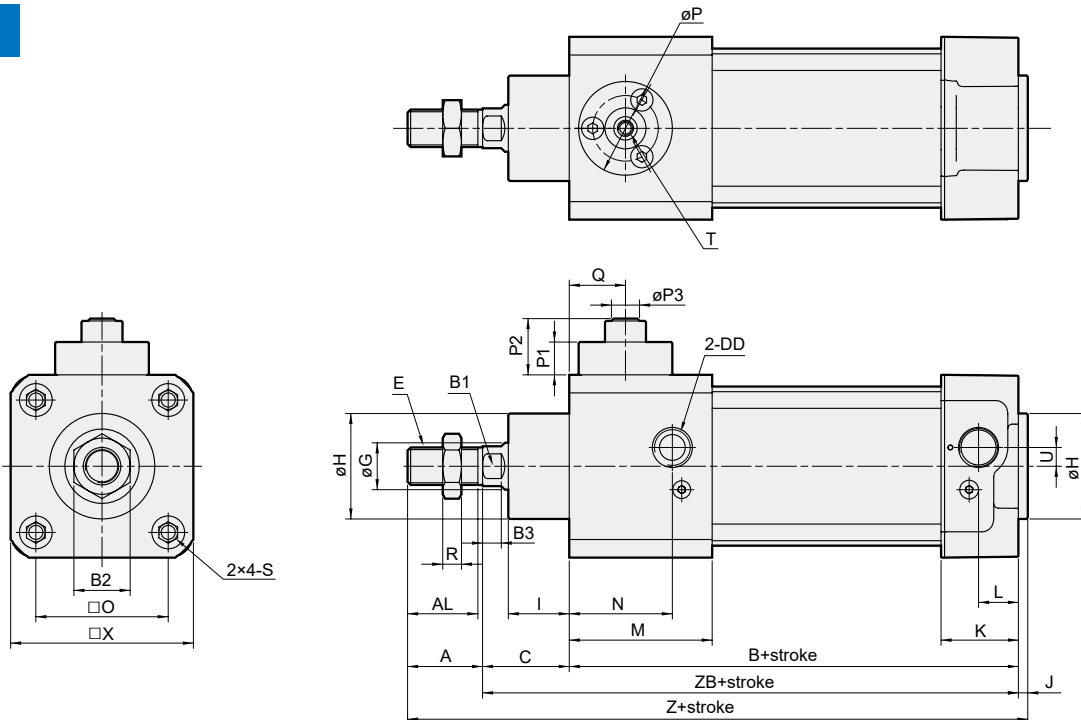

H

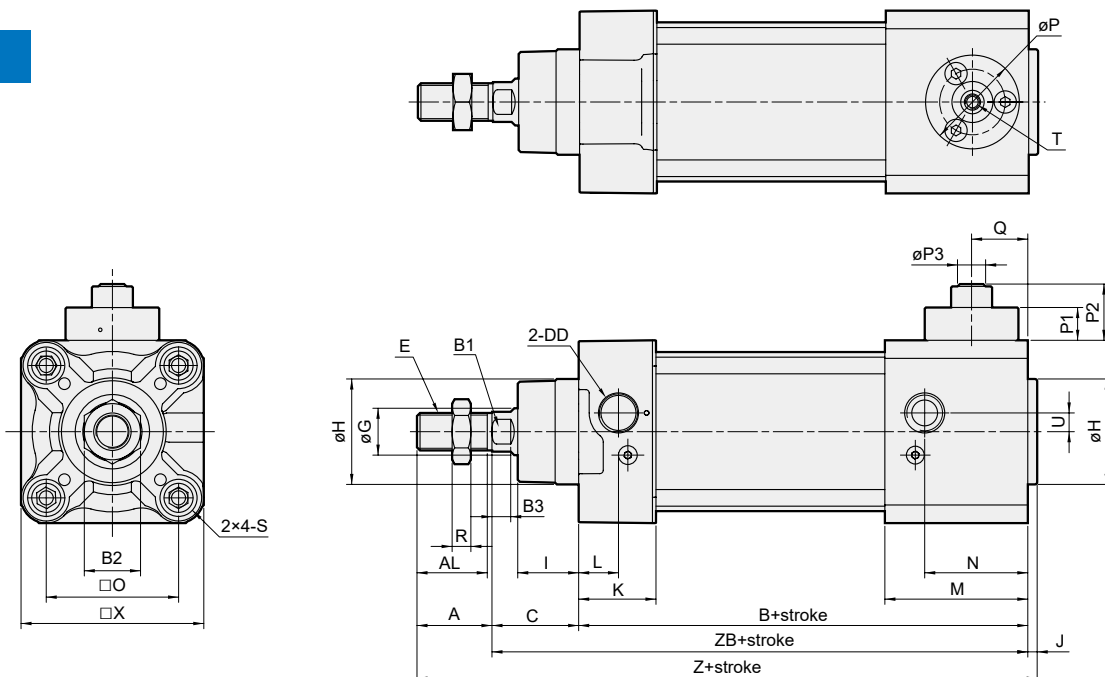

Code Tube I.D.	A	AL	B	B1	B2	B3	C	DD	E	G	H	I	J	K	L	M	N	O	P	P1	P2	P3	Q	R
63	32	30	149	17	24	8	37	G3/8	M16×1.5	20	45	26	4	33	17	61	44	56.5	40	14	24	12	24	8
80	40	38	168	22	30	10	46	G3/8	M20×1.5	25	45	32.5	4	35.5	20.5	75.5	60.5	72	50	12	16	14	26	10

Code Tube I.D.	S	T	U	X	Z	ZB
63	M8×1.25	M6×1.0	8	78	222	186
80	M10×1.5	M6×1.0	9	95	258	214



Features



Video



Special spec



Rod end shape



Technical data



Caution for safety
(Read before installing)

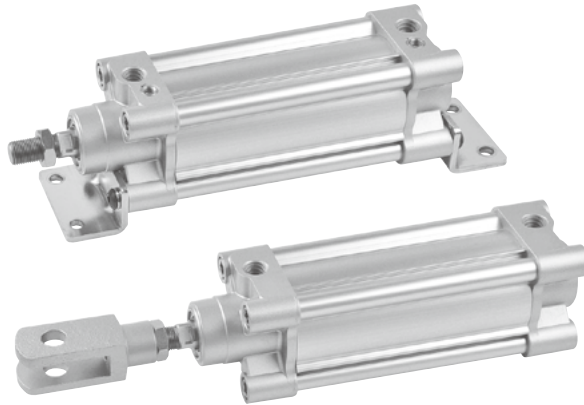

Features

■ Non lubrication

Special housing and bushing enables self lubrication of piston rod.

■ High quality long service life

Hard anodised aluminium cylinder tubes offer a high resistance to corrosion and low internal friction.

■ Automatic air cushioning

Pneumatic cushioning at both ends without adjusting.

■ Low noise level

Add cushion pad to reduce impact sound and vibration.

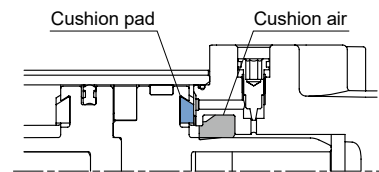

■ ISO 15552 standard specification

Conforms to ISO 15552 specification enabling worldwide interchangeability.

■ Easy to insert reed switch

With four grooves on the tube, proximity and reed sensors can be easily inserted into any position.

Table for standard stroke

Tube I.D.	Stroke (mm)	Max. stroke(mm)	
		Style 11	Style 21/27
ø32,40	50, 75, 100, 125, 150, 175,	1800	850
ø50,63	200, 250, 300, 350, 400, 450,	2000	950
ø80,100	500, 600, 700, 800	2500	1200



* Please contact us if the stroke is out of specification.

Order example

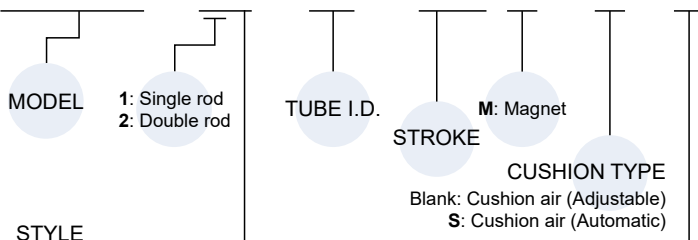
MCQI3 - 11 - 63 - 100 M - S - T



STYLE

Code	Symbol	Description
1 1		Double acting / Male thread
2 1		Double rod / Double acting / Male thread
2 7		Double rod / Adjustable male thread Please mark "adjustable stroke" at order list



TYPE

T: With magnet, TA/TB is assembled

* Tube, piston rod and tie rod are extended, and an extra piston is added.

* Rc or NPT thread are also available, please contact us.

Specification

Model	MCQI3
Tube I.D. (mm)	32, 40, 50, 63, 80, 100
Medium	Air
Operating pressure range	0.05~1 MPa
Proof pressure	1.5 MPa
Ambient temperature	-5~+60°C (No freezing)
Available speed range	50~500 mm/sec
Sensor switch	RDT, RQT  , RCI 

Accessories & Connector

Accessories							
Code	LB (Purchase 2 pcs)	CA	CA2	CB	CB2	CDB (Purchase CB+PIN)	CDB2 (Purchase CB2+PIN)
Mounting Tube I.D.							
ø32	LB-Q2-32	CA-Q2-32	CA2-Q2-32	CB-Q2-32	CB2-Q2-32	CDB-Q2-32	CDB2-Q2-32
ø40	LB-Q2-40	CA-Q2-40	CA2-Q2-40	CB-Q2-40	CB2-Q2-40	CDB-Q2-40	CDB2-Q2-40
ø50	LB-Q2-50	CA-Q2-50	CA2-Q2-50	CB-Q2-50	CB2-Q2-50	CDB-Q2-50	CDB2-Q2-50
ø63	LB-Q2-63	CA-Q2-63	CA2-Q2-63	CB-Q2-63	CB2-Q2-63	CDB-Q2-63	CDB2-Q2-63
ø80	LB-Q2-80	CA-Q2-80	CA2-Q2-80	CB-Q2-80	CB2-Q2-80	CDB-Q2-80	CDB2-Q2-80
ø100	LB-Q2-100	CA-Q2-100	CA2-Q2-100	CB-Q2-100	CB2-Q2-100	CDB-Q2-100	CDB2-Q2-100

Accessories				Rod nut	
Code	FAC	FBC	FAC2	FBC2	NUT
Mounting Tube I.D.					
ø32	FAC-Q2-32	FBC-Q2-32	FAC2-Q2-32	FBC2-Q2-32	NUT-M10x1.25x5Hx17B
ø40	FAC-Q2-40	FBC-Q2-40	FAC2-Q2-40	FBC2-Q2-40	NUT-M12x1.25x6Hx19B
ø50	FAC-Q2-50	FBC-Q2-50	FAC2-Q2-50	FBC2-Q2-50	NUT-M16x1.5x8Hx24B
ø63	FAC-Q2-63	FBC-Q2-63	FAC2-Q2-63	FBC2-Q2-63	
ø80	FAC-Q2-80	FBC-Q2-80	FAC2-Q2-80	FBC2-Q2-80	NUT-M20x1.5x10Hx30B
ø100	FAC-Q2-100	FBC-Q2-100	FAC2-Q2-100	FBC2-Q2-100	

Accessories Factory assembled and shipped (self-assembled is not recommended)				Connector		
Code	TA	TB	TC	Y	I	YS (Y+Floating pin)
Mounting Tube I.D.						
ø32		TC-Q3-32		Y-Q2-32	I-Q2-32	YS-Q2-32
ø40		TC-Q3-40		Y-Q2-40	I-Q2-40	YS-Q2-40
ø50		TC-Q3-50		Y-Q2-50	I-Q2-50	YS-Q2-50
ø63		TC-Q3-63				
ø80		TC-Q3-80		Y-Q2-80	I-Q2-80	YS-Q2-80
ø100		TC-Q3-100				

Pin

Applicable	YS connector	Y&I connector	CA&CB accessories
Code	PIN-S	PIN-Y-P (with split pin)	PIN-CB-P (with split pin)
Fig Tube I.D.			
ø32	PIN-Q2-32-S	PIN-Q2-32-2-P	PIN-Q2-32-1-P
ø40	PIN-Q2-40-S	PIN-Q2-40-2-P	PIN-Q2-40-1-P
ø50	PIN-Q2-50-S	PIN-Q2-50-2-P	PIN-Q2-50-1-P
ø63			PIN-Q2-63-1-P
ø80	PIN-Q2-80-S	PIN-Q2-80-2-P	PIN-Q2-80-1-P
ø100			PIN-Q2-100-1-P

Order example of self-assembled

The tube I.D. ø40 of LB accessories, Y connector and pin.

No.	Order number	Qty
1	LB-Q2-40	2
2	Y-Q2-40	1
3	PIN-Q2-40-2-P	1

* To order accessories/
connectors/ pin separately,
please place orders separately
according to the order codes
in the above table.

Order example of factory assembled

Cylinders and accessories are distinguished by the symbol "+".

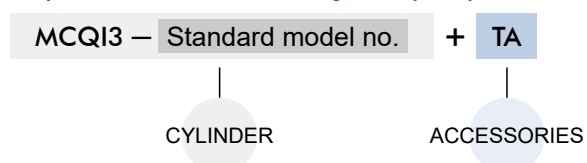

MCQI3-11 Inside structure & Parts list

ISO 15552 **STANDARD PROFILE CYLINDER**



Single rod 11 type

Cushion air (Adjustable)

ø32, ø40

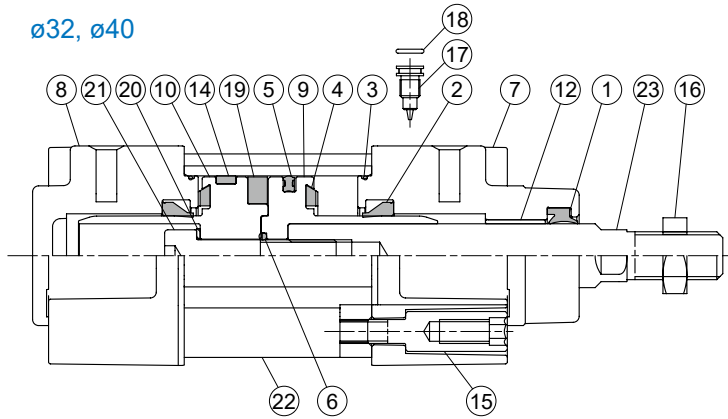

ø50

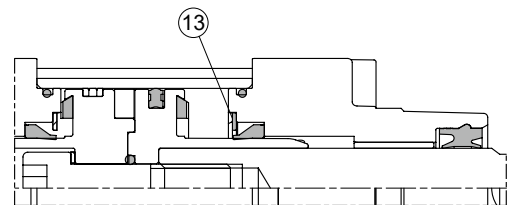

ø63

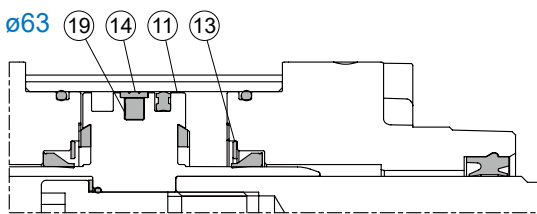

ø80, ø100

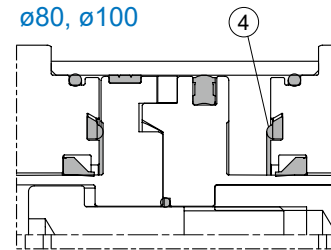

Material

No.	Part name	Material	Q'y	Component parts (inclusion)	Repair kits (inclusion)	Note
1	Rod packing	NBR / TPU	1	●	●	ø50, 63: TPU
2	Cushion packing	NBR	2	●	●	
3	O-ring	NBR	2	●	●	
4	Cushion pad	NBR	2	●	●	
5	Piston packing	NBR	1	●	●	
6	O-ring	NBR	1	●	●	
7	Rod cover	Aluminum alloy	1	●		
8	Head cover	Aluminum alloy	1	●		
9	Piston #1	Aluminum alloy	1	●		
10	Piston #2	Aluminum alloy	1	●		
11	Piston	Aluminum alloy	1	●		Only for ø63
12	Bush	Bearing alloy	1	●		
13	Washer	Carbon steel	2	●		Only for ø50, ø63
14	Wear ring	Resin	1	●		
15	Screw	Carbon steel	8	●		
16	Piston rod nut	Carbon steel	1	●		
17	Needle valve	Copper alloy	2	●		
18	O-ring	NBR	2	●		
19	Magnet ring	Magnet material	1	◎		◎ Option
20	Washer	Carbon steel	1	●		
21	Hex bolt	Carbon steel	1	●		
22	Cylinder tube	Aluminum alloy	1			
23	Piston rod *1	Carbon steel	1			

*1. When customized material is bearing steel, only two-side across flat (wrench flat) is available.

MCQI3-11-S Inside structure & Parts list

ISO 15552 **STANDARD PROFILE CYLINDER**



Single rod 11 type

Cushion air (Automatic)

ø32, ø40

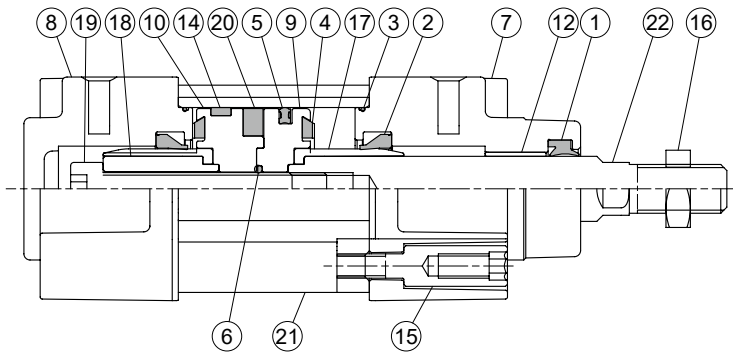

ø50

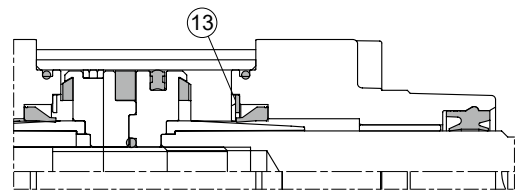

ø63

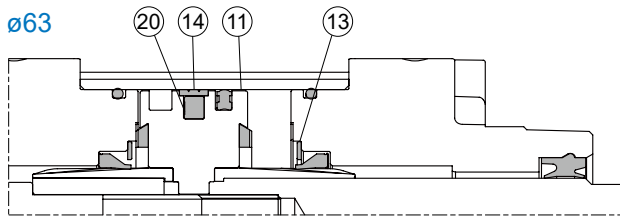

ø80, ø100

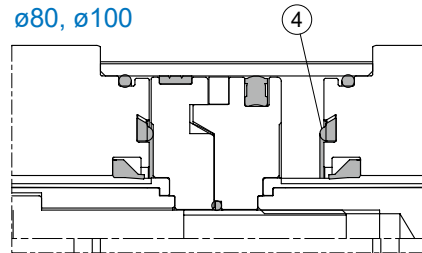

Material

No.	Part name	Material	Qty	Component parts (inclusion)	Repair kits (inclusion)	Note
1	Rod packing	NBR / TPU	1	●	●	ø50, 63: TPU
2	Cushion packing	NBR	2	●	●	
3	O-ring	NBR	2	●	●	
4	Cushion pad	NBR	2	●	●	
5	Piston packing	NBR	1	●	●	
6	O-ring	NBR	1	●	●	
7	Rod cover	Aluminum alloy	1	●		
8	Head cover	Aluminum alloy	1	●		
9	Piston #1	Aluminum alloy	1	●		
10	Piston #2	Aluminum alloy	1	●		
11	Piston	Aluminum alloy	1	●		Only for ø63
12	Bush	Bearing alloy	1	●		
13	Washer	Carbon steel	2	●		Only for ø50, ø63
14	Wear ring	Resin	1	●		
15	Screw	Carbon steel	8	●		
16	Piston rod nut	Carbon steel	1	●		
17	Shock absorber axis	Resin	2	●		
18	Piston nut	Aluminum alloy	1	●		
19	Hex bolt	Carbon steel	1	●		
20	Magnet ring	Magnet material	1	◎		◎ Option
21	Cylinder tube	Aluminum alloy	1			
22	Piston rod *1	Carbon steel	1			

*1. When customized material is bearing steel, only two-side across flat (wrench flat) is available.

MCQI3-21/27 Inside structure & Parts list

ISO 15552 **STANDARD PROFILE CYLINDER**



Double rod 21 / 27 type

Cushion air (Adjustable)

ø32, ø40

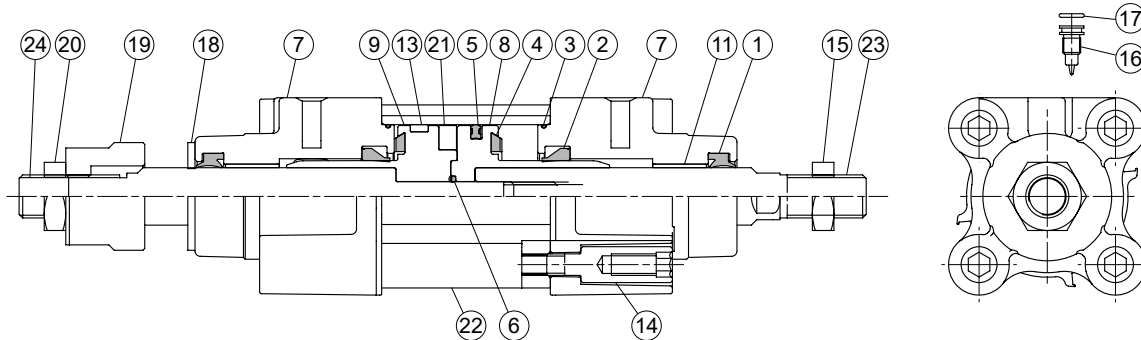

ø50

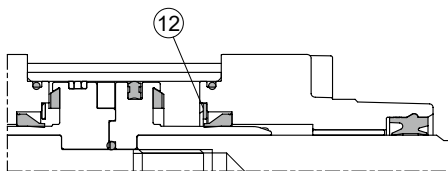

ø63

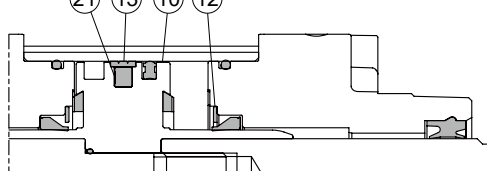

ø80, ø100

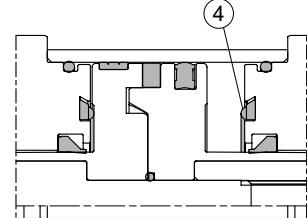

Material

No.	Part name	Material	Q'y	Component parts (inclusion)		Repair kits (inclusion)	Note
				21 type	27 type		
1	Rod packing	NBR / TPU	2	●	●	●	ø50, 63: TPU
2	Cushion packing	NBR	2	●	●	●	
3	O-ring	NBR	2	●	●	●	
4	Cushion pad	NBR	2	●	●	●	
5	Piston packing	NBR	1	●	●	●	
6	O-ring	NBR	1	●	●	●	
7	Rod cover	Aluminum alloy	2	●	●		
8	Piston #1	Aluminum alloy	1	●	●		
9	Piston #2	Aluminum alloy	1	●	●		
10	Piston	Aluminum alloy	1	●	●		Only for ø63
11	Bush	Bearing alloy	2	●	●		
12	Washer	Carbon steel	2	●	●		Only for ø50, ø63
13	Wear ring	Resin	1	●	●		
14	Screw	Carbon steel	8	●	●		
15	Piston rod nut	Carbon steel	1	●	●		
16	Needle valve	Copper alloy	2	●	●		
17	O-ring	NBR	2	●	●		
18	Gasket	PU	1		●		
19	Adjustable nut	Carbon steel	1		●		
20	Hex nut	Carbon steel	1		●		
21	Magnet ring	Magnet material	1	◎	◎		◎ Option
22	Cylinder tube	Aluminum alloy	1				
23	Piston rod #1 *1	Carbon steel	1				
24	Piston rod #2 *1	Carbon steel	1				

*1. When customized material is bearing steel, only two-side across flat (wrench flat) is available.

MCQI3-21/27-S Inside structure & Parts list

ISO 15552 **STANDARD PROFILE CYLINDER**



Double rod 21 / 27 type

Cushion air (Automatic)

ø32, ø40

ø50

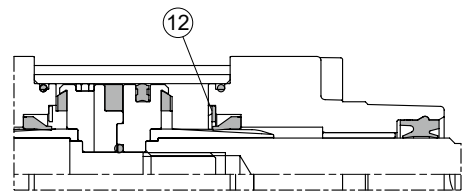
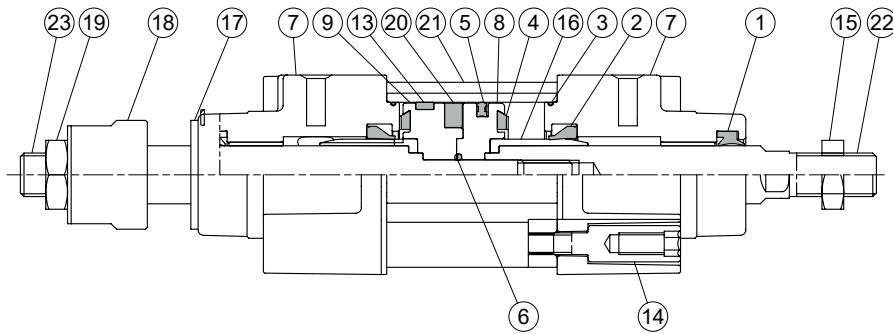

ø63

ø80, ø100

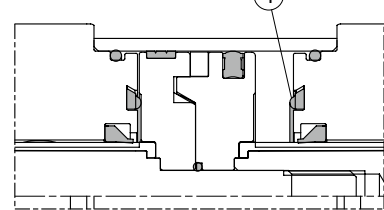
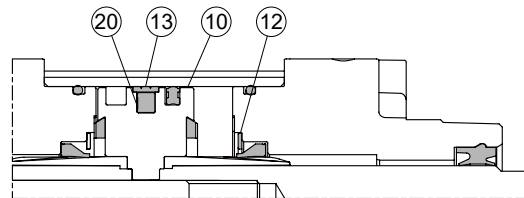

Material

No.	Part name	Material	Q'y	Component parts (inclusion)		Repair kits (inclusion)	Note
				21 type	27 type		
1	Rod packing	NBR / TPU	2	●	●	●	ø50, 63: TPU
2	Cushion packing	NBR	2	●	●	●	
3	O-ring	NBR	2	●	●	●	
4	Cushion pad	NBR	2	●	●	●	
5	Piston packing	NBR	1	●	●	●	
6	O-ring	NBR	1	●	●	●	
7	Rod cover	Aluminum alloy	2	●	●		
8	Piston #1	Aluminum alloy	1	●	●		
9	Piston #2	Aluminum alloy	1	●	●		
10	Piston	Aluminum alloy	1	●	●		Only for ø63
11	Bush	Bearing alloy	2	●	●		
12	Washer	Carbon steel	2	●	●		Only for ø50, ø63
13	Wear ring	Resin	1	●	●		
14	Screw	Carbon steel	8	●	●		
15	Piston rod nut	Carbon steel	1	●	●		
16	Shock absorber axis	Resin	2	●	●		
17	Gasket	PU	1		●		
18	Adjustable nut	Carbon steel	1		●		
19	Hex nut	Carbon steel	1		●		
20	Magnet ring	Magnet material	1	◎	◎		◎ Option
21	Cylinder tube	Aluminum alloy	1				
22	Piston rod #1 *1	Carbon steel	1				
23	Piston rod #2 *1	Carbon steel	1				

*1. When customized material is bearing steel, only two-side across flat (wrench flat) is available.

Order example of component parts

CP – MCQI3 – 2 – 63 M S

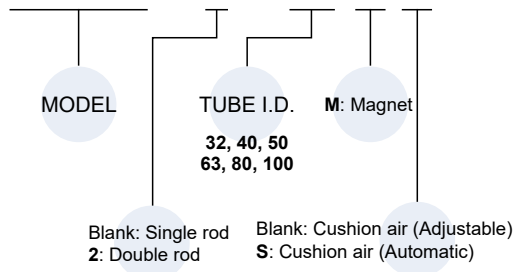

Order example of repair kits

PS – MCQI3 – 2 – 63 S – XB6

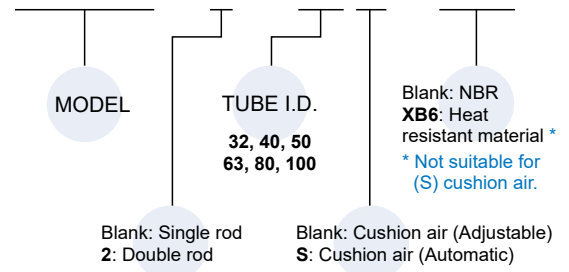

* Order example for Rc or NPT thread please contact us.

Cylinder & accessories weight

Cylinder weight

Unit: kg

Model	Basic weight MCQI3-11	Basic weight (magnet) MCQI3-11	Basic weight MCQI3-11-S	Basic weight (magnet) MCQI3-11-S	Stroke 25 mm MCQI3-11-(S)
Tube I.D.					
ø32	0.534	0.540	0.531	0.537	0.062
ø40	0.789	0.801	0.783	0.795	0.088
ø50	1.300	1.317	1.293	1.310	0.120
ø63	1.785	1.805	1.774	1.794	0.129
ø80	2.653	2.680	2.638	2.665	0.185
ø100	3.949	3.984	3.885	3.920	0.236

Accessories weight

Unit: kg

Model	LB	CA	CA2	CB	CB2	CDB	CDB2	FAC/ FBC	FAC2/ FBC2	TA/TB/TC
Tube I.D.										
ø32	0.163	0.213	0.07	0.185	0.07	0.170	0.06	0.235	0.07	0.208
ø40	0.211	0.253	0.09	0.211	0.10	0.230	0.08	0.265	0.09	0.282
ø50	0.315	0.390	0.16	0.352	0.15	0.410	0.12	0.460	0.17	0.377
ø63	0.395	0.670	0.23	0.544	0.23	0.550	0.18	0.684	0.20	0.675
ø80	0.816	1.076	0.40	0.982	0.45	0.870	0.28	1.508	0.40	1.025
ø100	1.014	1.587	0.50	1.493	0.60	1.400	0.45	1.975	0.56	1.680

Model	Y	I	Pin		YS
			Y / I	CA / CB	
Tube I.D.					
ø32	0.070	0.080	0.02	0.040	0.018
ø40	0.115	0.141	0.03	0.065	0.031
ø50	0.272	0.334	0.08	0.072	0.070
ø63	0.272	0.334	0.08	0.145	0.070
ø80	0.551	0.553	0.16	0.179	0.150
ø100	0.551	0.553	0.16	0.330	0.150

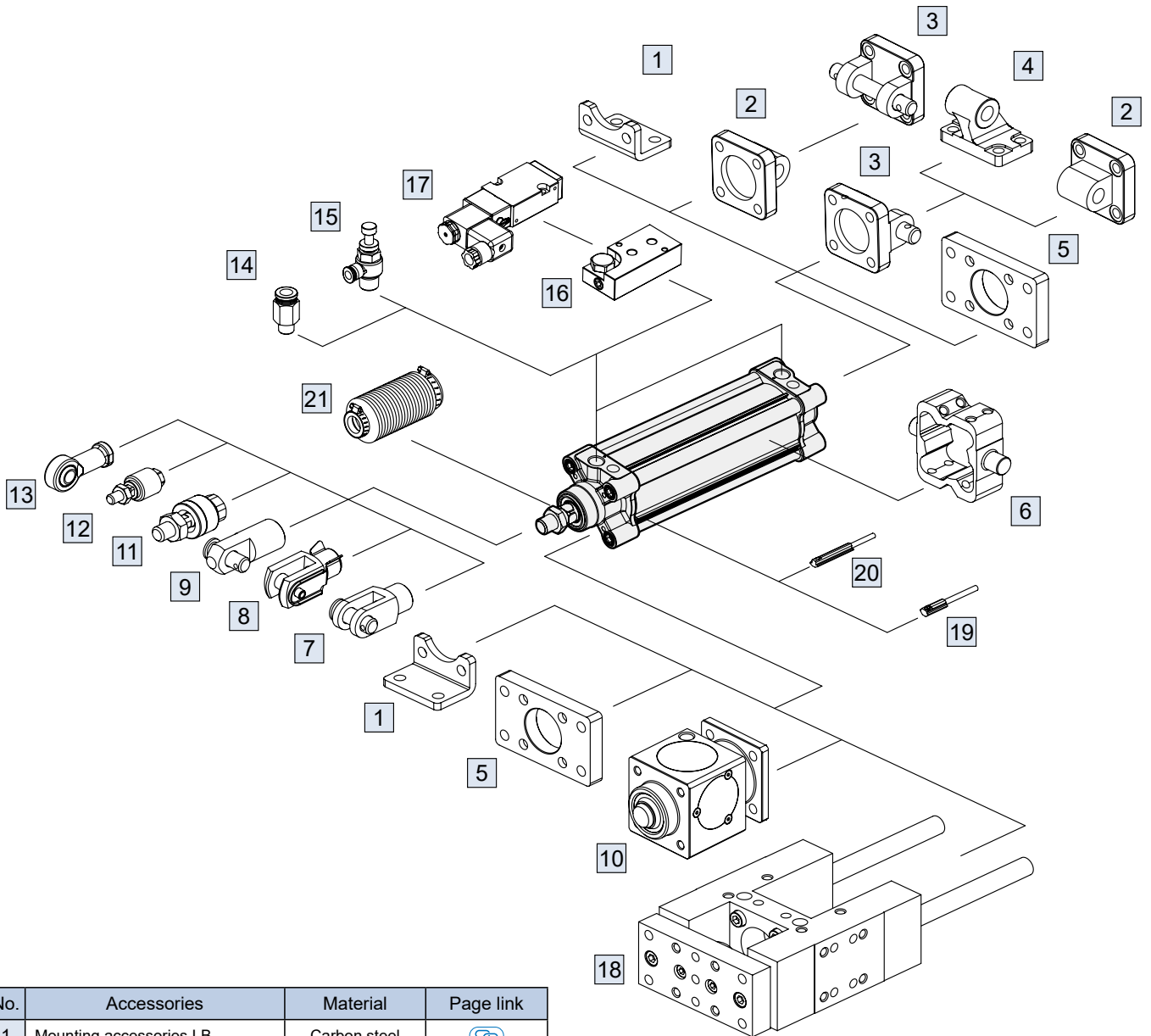

No.	Accessories	Material	Page link
1	Mounting accessories LB	Carbon steel	↗
2	Mounting accessories CA	Cast iron	↗
	Mounting accessories CA2	Aluminum alloy	↗
3	Mounting accessories CB+PIN	Cast iron / *1	↗ , ↗
	Mounting accessories CB2+PIN	Aluminum alloy	↗ , ↗
4	Mounting accessories CDB	Cast iron	↗
	Mounting accessories CDB2	Aluminum alloy	↗
5	Mounting accessories FAC/FBC	Carbon steel	↗
	Mounting accessories FAC2/FBC2	Aluminum alloy	↗
6	Mounting accessories TA/TB/TC	Cast iron	↗
7	Accessories Y+PIN	Cast iron / *1	↗
8	Accessories YS (Y+Floating pin)	Carbon steel	↗
9	Accessories I+PIN	Carbon steel	↗
10	Locking unit MCBQI3	Aluminum alloy+*2	↗

No.	Accessories	Material	Page link
11	Floating joint MFC	Carbon steel	↗
12	Floating joint MFCS	Carbon steel	↗
13	Female rod ends PHS	Carbon steel	↗
14	Fitting PC (PISCO)	—	↗
15	Speed controller JSC (PISCO)	—	↗
16	Cylinder link seats MVSN-300-C *3	Aluminum alloy	↗
17	Solenoid valve MVSN-220 / 300 *3	—	↗ , ↗
18	Twin-guide cylinders MGTB/TU/TX	—	↗
19	Sensor switch R*T	—	↗
20	Sensor switch RCI	—	↗
21	Protective bellows kit	NBR	—

*1. PIN material is carbon steel. *2. Bronze alloy.
*3. Only for tube I.D. ø40, ø50.

11

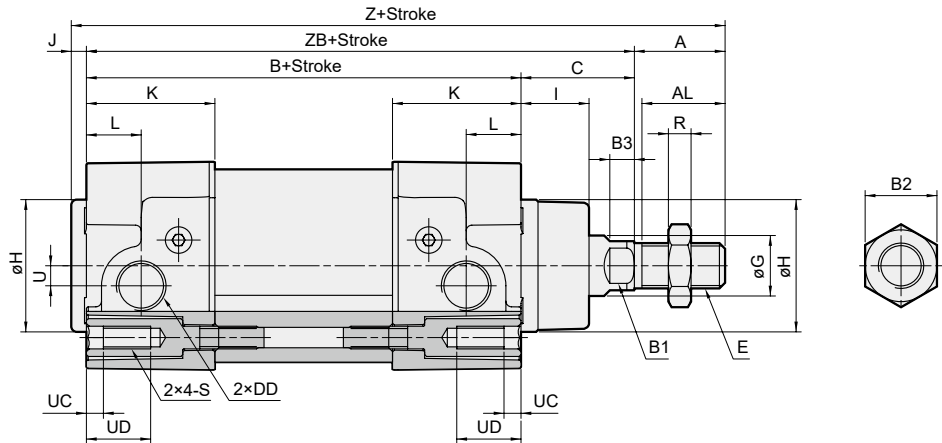
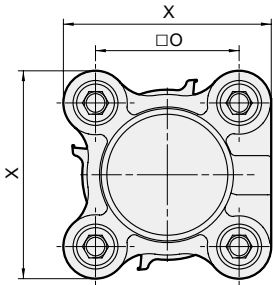

21

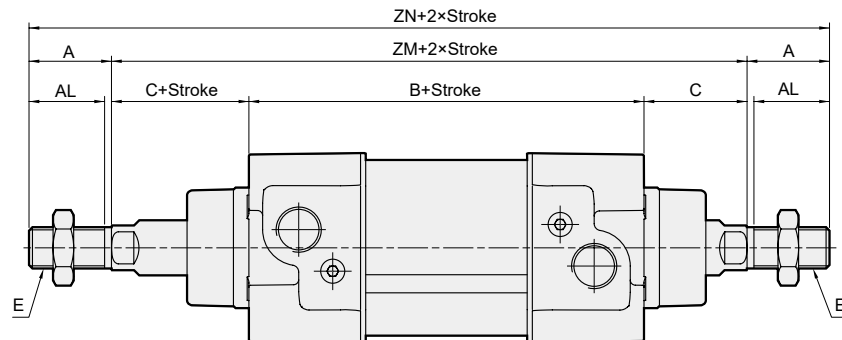

27

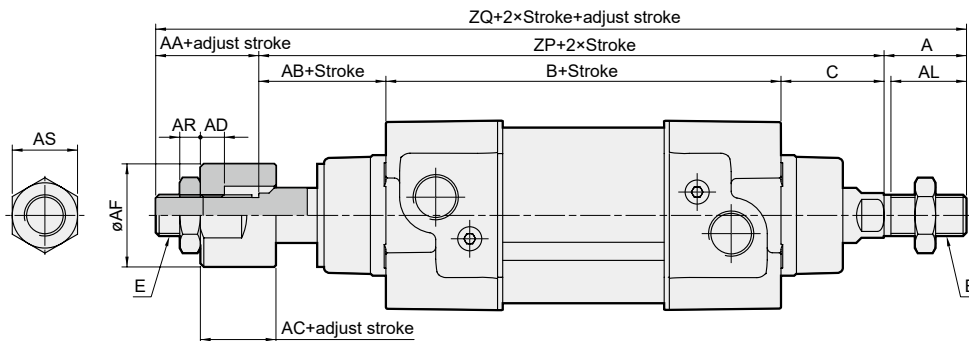

Code Tube I.D.	A	AA	AB	AC	AD	AE	AF	AL	AR	AS	B	B1	B2	B3	C	DD	E	G	H	I	J	K	L	O
32	22	16	26	12	7	M10×1.25	20	20	5	17	94	10	17	4	26	G1/8	M10×1.25	12	30	15	4	30.5	20	32.5
40	24	20	27	12	7	M12×1.25	30	22	6	19	105	13	19	6.5	30	G1/4	M12×1.25	16	35	18	4	34	14.5	38
50	32	18	34	15	10	M16×1.5	40	30	8	24	106	17	24	6	37	G1/4	M16×1.5	20	40	28	4	31	16	46.5
63	32	20	32	15	10	M16×1.5	40	30	8	24	121	17	24	8	37	G3/8	M16×1.5	20	45	26	4	33	17	56.5
80	40	32	41	20	14	M22×1.5	50	38	13	32	128	22	30	10	46	G3/8	M20×1.5	25	45	32.5	4	35.5	20.5	72
100	40	30	46	20	14	M22×1.5	50	38	13	32	138	22	30	10	51	G1/2	M20×1.5	25	55	37.5	4	37	19	89

Code Tube I.D.	R	S	U	UC	UD	X	Z	ZB	ZM	ZN	ZP	ZQ
32	5	M6×1.0	4.5	4.5	16	47	146	120	146	190	146	184
40	6	M6×1.0	5.3	4.5	16	55	163	135	165	213	162	206
50	8	M8×1.25	8.5	4.5	16	65	179	143	180	244	177	227
63	8	M8×1.25	8	4.5	16	78	194	158	195	259	190	242
80	10	M10×1.5	9	4.5	18	95	218	174	220	300	215	287
100	10	M10×1.5	13	4.5	18	115	233	189	240	320	235	305

■ Installation of sensor switch

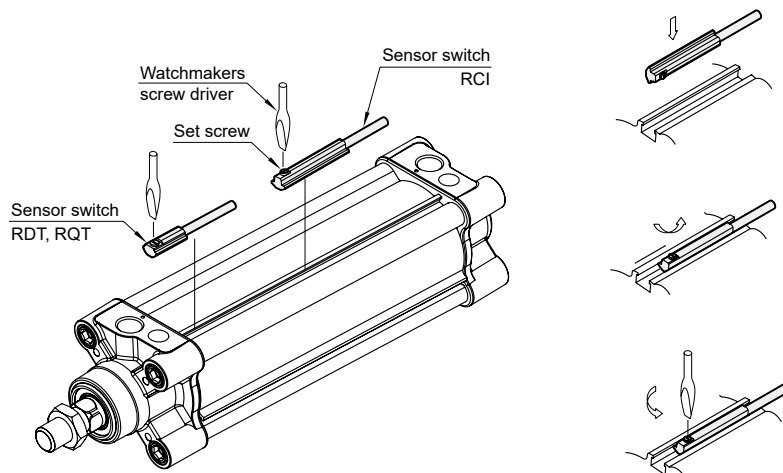

■ Mounting accessories

LB

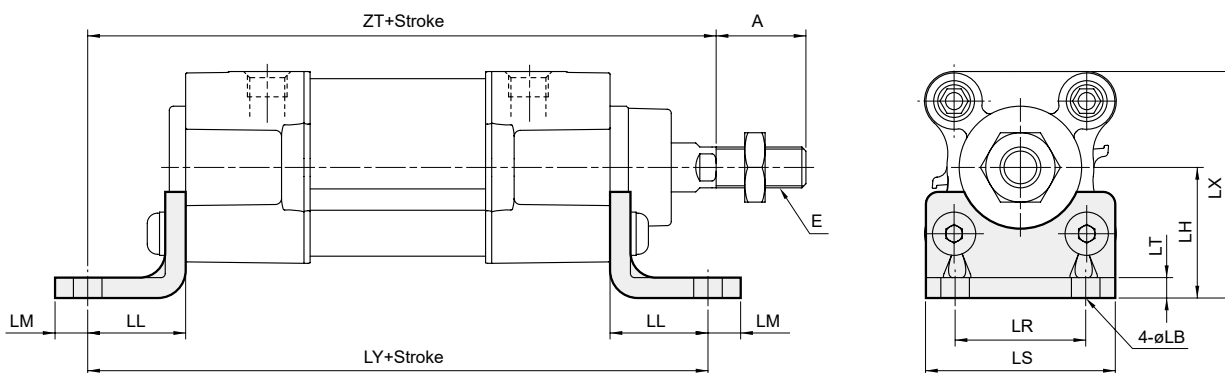

Code Tube I.D.	A	E	LB	LH	LL	LM	LR	LS	LT	LX	LY	ZT
32	22	M10×1.25	7	32	24	8	32	47	5	55.5	142	144
40	24	M12×1.25	9	36	28	10	36	53	5	63.2	161	163
50	32	M16×1.5	9	45	32	10	45	65	5	77.5	170	175
63	32	M16×1.5	9	50	32	10	50	75	5	89.0	185	190
80	40	M20×1.5	12	63	41	13	63	95	6	110.5	210	215
100	40	M20×1.5	14	71	41	13	75	115	6	128.5	220	230

FAC

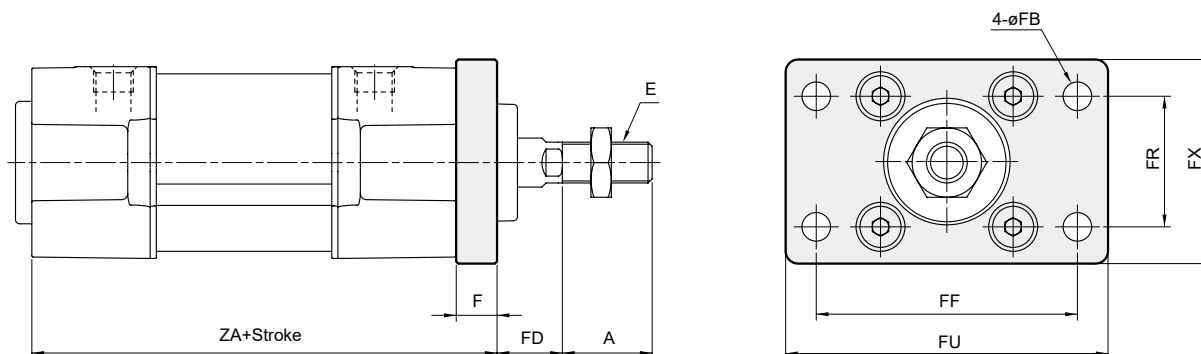

FBC

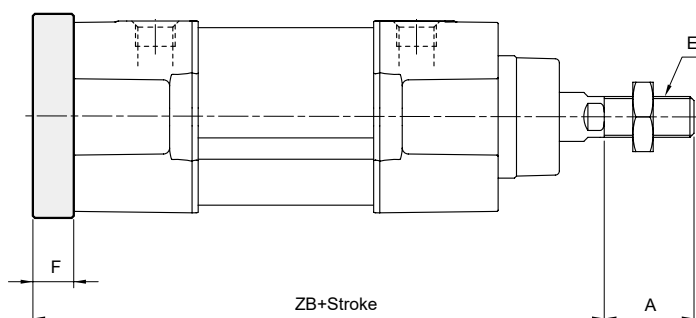

Code Tube I.D.	A	E	F	FB	FD	FF	FR	FU	FX	ZA	ZB
32	22	M10×1.25	10	7	16	64	32	79	50	104	130
40	24	M12×1.25	10	9	20	72	36	90	52	115	145
50	32	M16×1.5	12	9	25	90	45	110	65	118	155
63	32	M16×1.5	12	9	25	100	50	125	76	133	170
80	40	M20×1.5	16	12	30	126	63	154	94	144	190
100	40	M20×1.5	16	14	35	150	75	180	112	154	205

FAC2

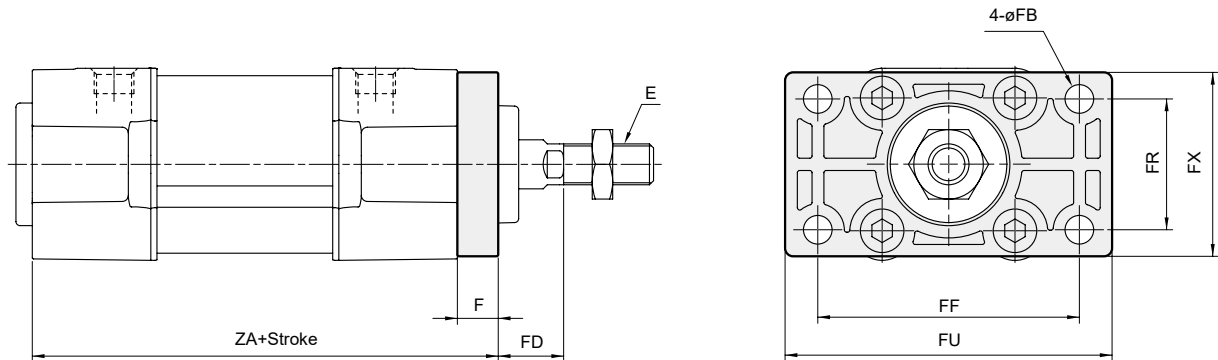

FBC2

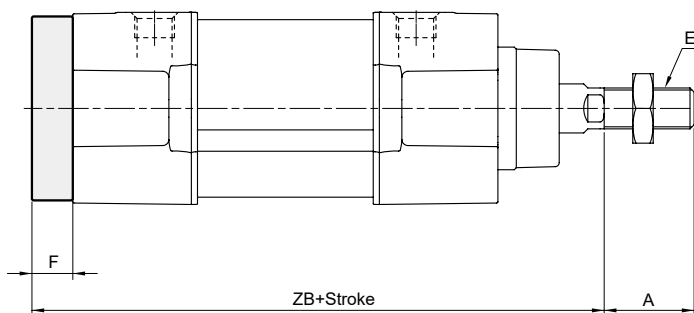

Code Tube I.D.	A	E	F	FB	FD	FF	FR	FU	FX	ZA	ZB
32	22	M10×1.25	10	7	16	64	32	80	45	104	130
40	24	M12×1.25	10	9	20	72	36	90	52	115	145
50	32	M16×1.5	12	9	25	90	45	110	65	118	155
63	32	M16×1.5	12	9	25	100	50	120	75	133	170
80	40	M20×1.5	16	12	30	126	63	150	95	144	190
100	40	M20×1.5	16	14	35	150	75	175	115	154	205

CA

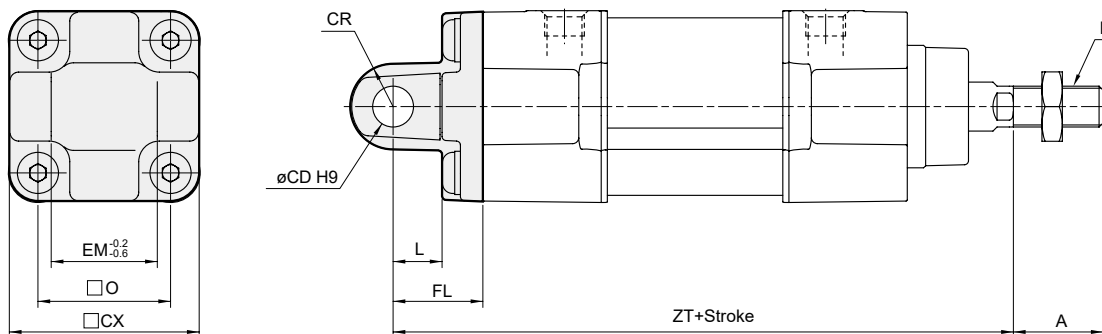

CB

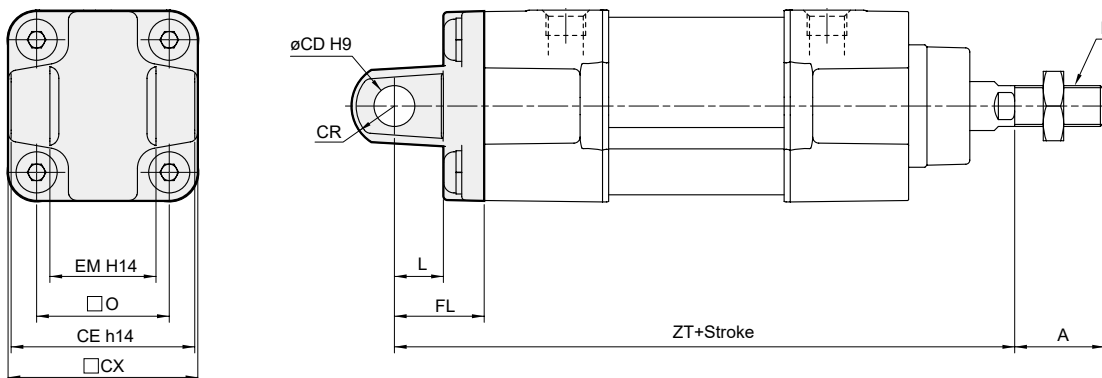

CDB

CB+Pin (Extra purchase)

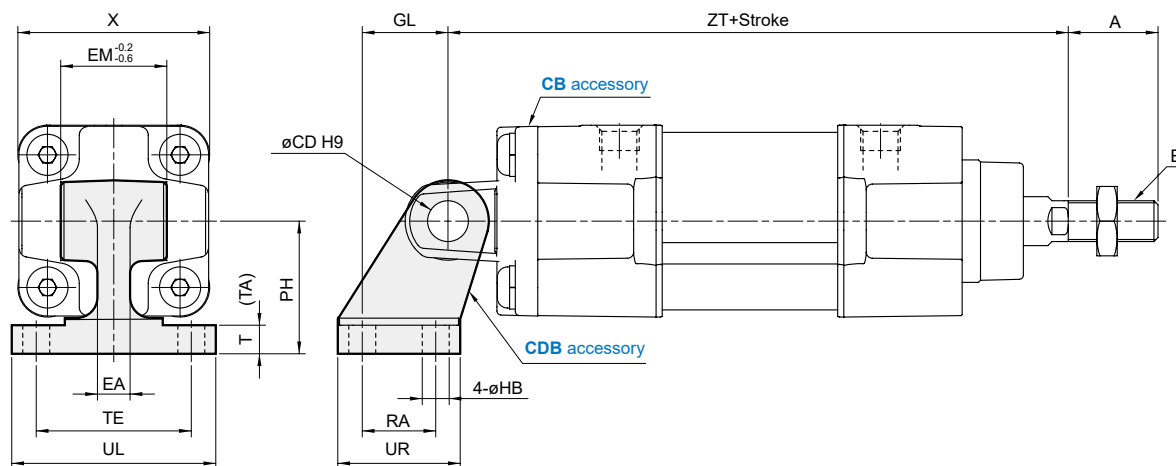

Code Tube I.D.	A	CD	CE	CR	CX	E	EA	EM	FL	GL	HB	L	O	PH	RA	T	TA	TE	UL	UR	X	ZT
32	22	10	45	R10.5	46.5	M10×1.25	8	26	22	21	6.6	12	32.5	32	18	6.5	1.5	38	50	30	47	142
40	24	12	52	R12	54	M12×1.25	10	28	25	24	6.6	15	38	36	22	8.5	1.5	41	53	34	55	160
50	32	12	60	R13	64	M16×1.5	10	32	27	33	9	15	46.5	45	30	10.5	1.5	50	65	45	65	170
63	32	16	70	R17	75	M16×1.5	12	40	32	37	9	20	56.5	50	35	10.5	1.5	52	67	50	78	190
80	40	16	90	R17	93	M20×1.5	12	50	36	47	11	20	72	63	40	11.5	2.5	66	86	60	95	210
100	40	20	110	R21	114	M20×1.5	16	60	41	55	11	25	89	71	50	12.5	2.5	76	96	70	115	230

CA2

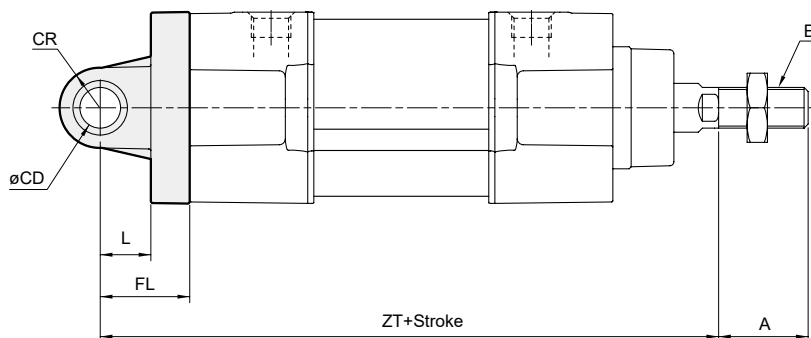
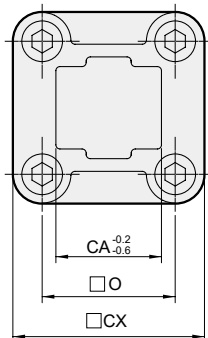

CB2

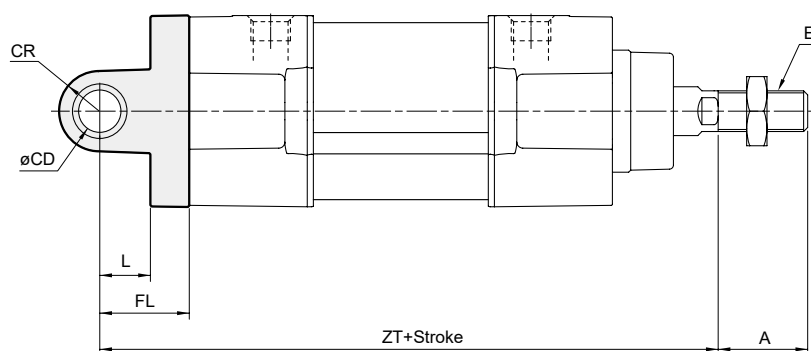
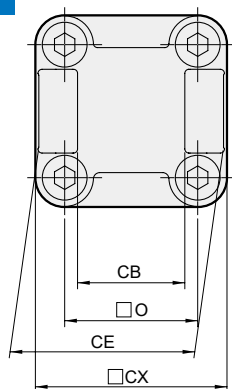

CDB2

CB2+Pin (Extra purchase)

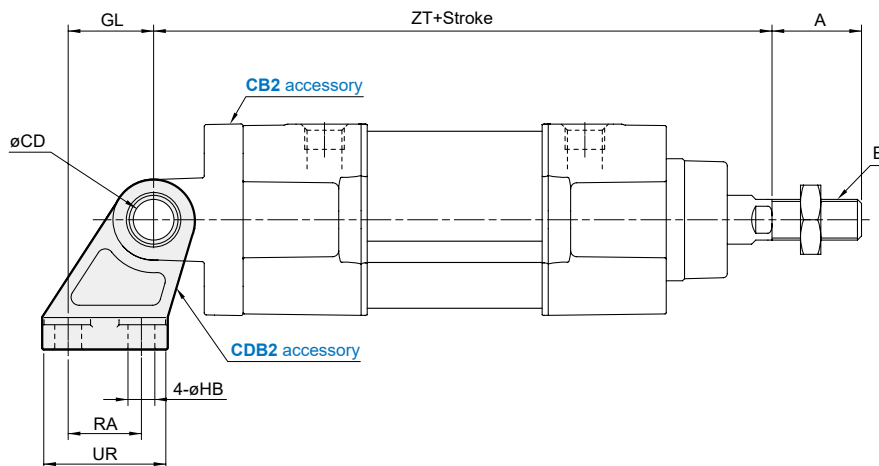
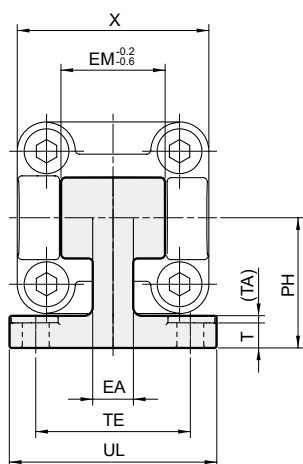

Code Tube I.D.	A	CA	CB ^{H14}	CD ^{H9}	CE ^{H14}	CR	CX	E	EA	EM	FL	GL	HB	L	O	PH	RA	T	TA	TE	UL	UR	X	ZT
32	22	26	26 ^{+0.052} ₀	10 ^{+0.036} ₀	45 ⁰ _{-0.62}	R10	47	M10×1.25	10	26	22	21	6.6	12.5	32.5	32	18	8	1.6	38	51	31	47	142
40	24	28	28 ^{+0.052} ₀	12 ^{+0.043} ₀	52 ⁰ _{-0.74}	R12	53	M12×1.25	15	28	25	24	6.6	16	38	36	22	10	1.6	41	54	35	55	160
50	32	32	32 ^{+0.062} ₀	12 ^{+0.043} ₀	60 ⁰ _{-0.74}	R12	65	M16×1.5	16	32	27	33	9	16	46.5	45	30	12	1.6	50	65	45	65	170
63	32	40	40 ^{+0.062} ₀	16 ^{+0.043} ₀	70 ⁰ _{-0.74}	R16	75	M16×1.5	16	40	32	37	9	21	56.5	50	35	14	1.6	52	67	50	78	190
80	40	50	50 ^{+0.062} ₀	16 ^{+0.043} ₀	90 ⁰ _{-0.87}	R16	95	M20×1.5	20	50	36	47	11	22	72	63	40	14	2.5	66	86	60	95	210
100	40	60	60 ^{+0.074} ₀	20 ^{+0.052} ₀	110 ⁰ _{-0.87}	R20	115	M20×1.5	20	60	41	55	11	27	89	71	50	17	2.5	76	96	70	115	230

TC

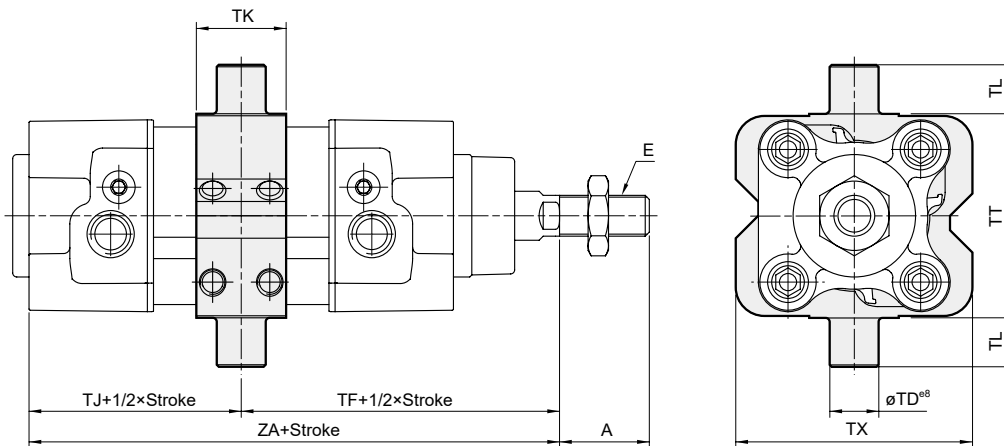

TA

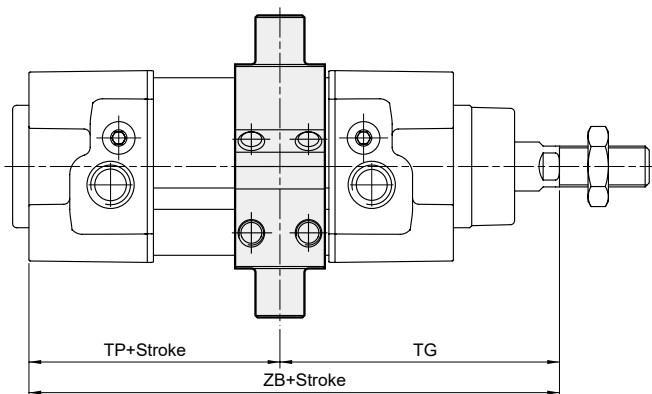

TB

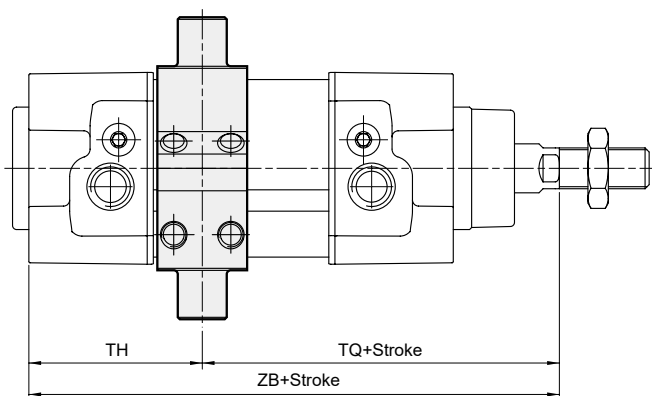

Code Tube I.D.	A	E	TD	TF	TG	TH	TJ	TK	TL	Without magnet			Magnet			TT	TX	ZA
										TP	TQ	ZB	TP	TQ	ZB			
32	22	M10×1.25	12	73	70.5	44.5	47	22	12	49.5	75.5	120	79.5	105.5	150	50	58	120
40	24	M12×1.25	16	82.5	81	51	52.5	28	16	54	84	135	84	114	165	63	70	135
50	32	M16×1.5	16	90	87	50	53	32	16	56	93	143	86	123	173	75	85	143
63	32	M16×1.5	20	97.5	90.5	53.5	60.5	35	20	67.5	104.5	158	97.5	134.5	188	90	100	158
80	40	M20×1.5	20	110	104.5	58.5	64	40	20	69.5	115.5	174	109.5	155.5	214	110	120	174
100	40	M20×1.5	25	120	113.5	62.5	69	45	25	75.5	126.5	189	115.5	166.5	229	132	145	189

Order example

MCQI3 — As standard order example — VR — 4E2C — 6A — AC110 — L

MODEL

SOLENOID VALVE
LINK SEATS

4 way (5 port)

E1: Single solenoid
E2: Double solenoid

PORT
SIZE

VOLTAGE

VR: Installed on the front cover
VH: Installed on the back cover

C: Closed center
P: Pressure center
R: Exhaust center
(Only for
MVSN-300-4E2)

6A: G1/8
(Only for
MVSN-220)
8A: G1/4

AC220V(50/60)Hz
AC110V(50/60)Hz
DC24V

* MCQI3- $\varnothing 40$ (for MVSN-220 valve)

* MCQI3- $\varnothing 50$ (for MVSN-300 valve)

ELECTRIC CONNECTION

Standard	
Blank	DIN terminal
L	DIN terminal with LED indicator
E	Explosion protection
Power saving (for DC24V)	
KL	DIN terminal with LED indicator

MVSN-300-C

Solenoid valve link seats

Mounting of solenoid valve link seats

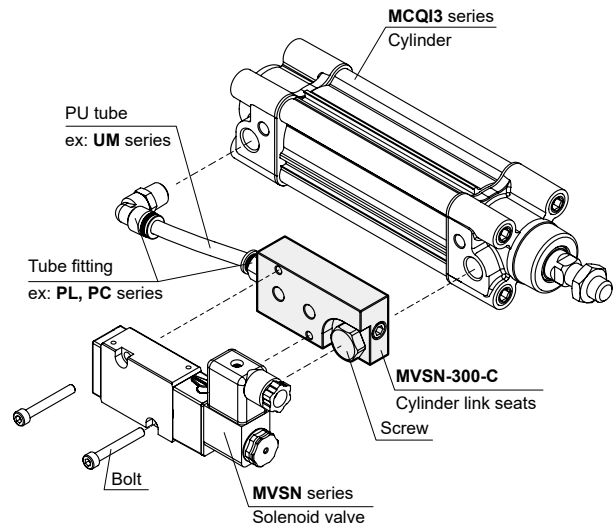
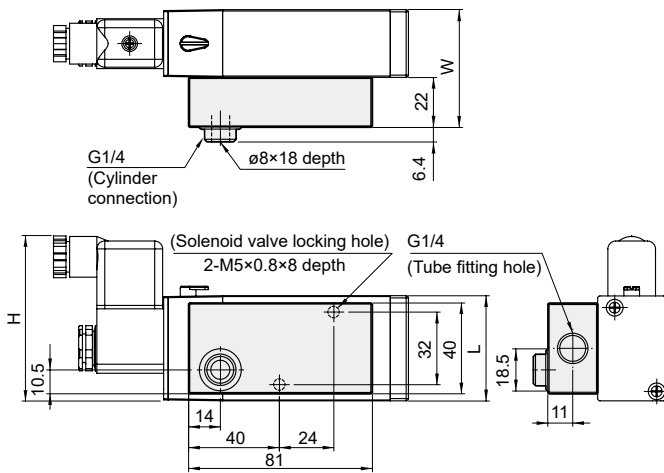

Code Model	H	W	L	Cylinder type
MVSN-220	70	44.3	40	MCQV3/MCQI3 $\varnothing 40$
MVSN-300	73	52	46.4	MCQV3/MCQI3 $\varnothing 50$



Special spec



Technical data



Caution for safety
(Read before installing)



Features

■ Hexagonal rod design & Non lubrication

Cylinder with hexagonal rod design for non-rotating feature. Special housing and bushing enables self lubrication of piston rod.

■ High quality long service life

Hard anodised aluminium cylinder tubes offer high corrosion resistance and low internal friction.

■ Low noise level

Add cushion pad to reduce impact sound and vibration.

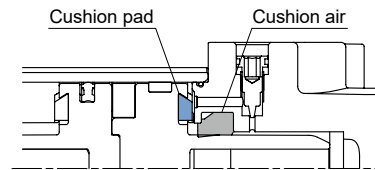

■ ISO 15552 standard specification

Conforms to ISO 15552 specification, make worldwide interchangeability.

■ Easy to insert reed switch

With four grooves on the tube, proximity and reed sensors can be easily inserted into any position.

Table for standard stroke

Tube I.D.	Stroke (mm)	Max. stroke (mm)
ø32,40	50,75,100,125,150, 175,200,300,400,500	700

* Intermediate stroke are available, please contact us.

Tightening torque

Tube I.D.	Rod thread	Tightening torque (kgf-cm)
ø32	M10×1.25	190
ø40	M12×1.25	330

* Make sure the tightening torque of rod thread does not exceed the value above.

* The tolerance of tightening torque is ±5%.

Specification

Model	MCKQI3	
Tube I.D. (mm)	32	40
Medium	Air	
Operating pressure range	0.05~1 MPa	
Proof pressure	1.5 MPa	
Ambient temperature	-5~+60°C (No freezing)	
Available speed range	50~500 mm/sec	
Rod non-rotating accuracy	±0.5°	
Allowable rotational torque	2.5 kgf-cm	4.5 kgf-cm
Sensor switch	RDT, RQT , RCI	

Order example

MCKQI3 — 11 — 32 — 100M — T

MODEL

TUBE I.D.

STROKE

M: Magnet

TYPE

STYLE

T: With magnet, TA/TB is assembled

* Tube, piston rod and tie rod are extended, and an extra piston is added.

Code	Symbol	Description
1 1		Double acting / Male thread

* Rc or NPT thread are also available, please contact us.

Caution

Please don't attempt to rotate the piston rod.

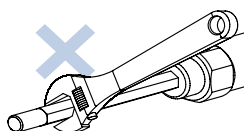

Accessories & Connector

Code	Accessories						Rod nut
	LB (Purchase 2 pcs)	CA	CB	CDB (Purchase CB+PIN)	FAC	FBC	NUT
Mounting Tube I.D.							
ø32	LB-Q2-32	CA-Q2-32	CB-Q2-32	CDB-Q2-32	FAC-Q2-32		NUT-M10x1.25x5Hx17B
ø40	LB-Q2-40	CA-Q2-40	CB-Q2-40	CDB-Q2-40	FAC-Q2-40		NUT-M12x1.25x6Hx19B

Code	Accessories Factory assembled and shipped (self-assembled is not recommended)			Connector		
	TA	TB	TC	Y	I	YS (Y+Floating pin)
Mounting Tube I.D.						
ø32	TC-Q3-32			Y-Q2-32	I-Q2-32	YS-Q2-32
ø40	TC-Q3-40			Y-Q2-40	I-Q2-40	YS-Q2-40

Pin

Applicable	YS connector	Y&I connector	CA&CB accessories
Code	PIN-S	PIN-Y-P (with split pin)	PIN-CB-P (with split pin)
Fig Tube I.D.			
ø32	PIN-Q2-32-S	PIN-Q2-32-2-P	PIN-Q2-32-1-P
ø40	PIN-Q2-40-S	PIN-Q2-40-2-P	PIN-Q2-40-1-P

Order example of self-assembled

The tube I.D. ø40 of LB accessories, Y connector and pin.

No.	Order number	Qty
1	LB-Q2-40	2
2	Y-Q2-40	1
3	PIN-Q2-40-2-P	1

* To order accessories/
connectors/ pin separately,
please place orders separately
according to the order codes
in the above table.

Order example of factory assembled

Cylinders and accessories are distinguished by the symbol " + ".

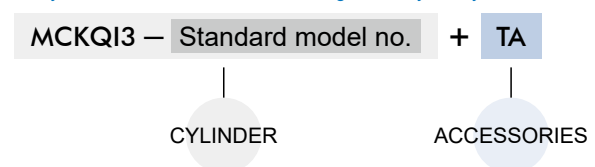

Cylinder weight

Unit: kg

Model	Basic weight	Basic weight (magnet)	Stroke 25 mm
Tube I.D.			
ø32	0.507	0.513	0.065
ø40	0.758	0.770	0.088

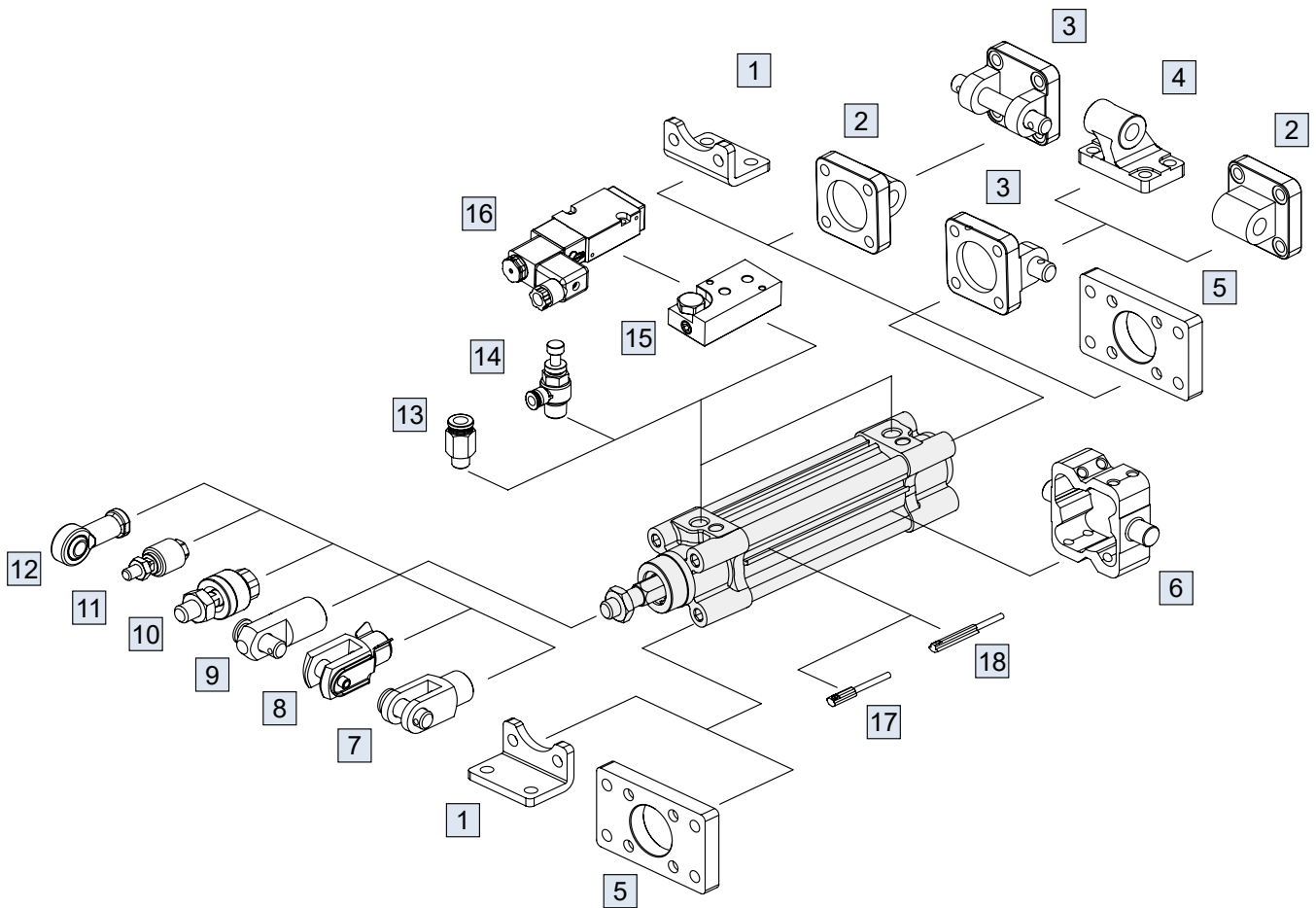

No.	Accessories	Material	Page link
1	Mounting accessories LB	Carbon steel	🔗
2	Mounting accessories CA	Cast iron	🔗
	Mounting accessories CA2	Aluminum alloy	🔗
3	Mounting accessories CB+PIN	Cast iron / *1	🔗 , 🔗
	Mounting accessories CB2+PIN	Aluminum alloy	🔗 , 🔗
4	Mounting accessories CDB	Cast iron	🔗
	Mounting accessories CDB2	Aluminum alloy	🔗
5	Mounting accessories FAC/FBC	Carbon steel	🔗
	Mounting accessories FAC2/FBC2	Aluminum alloy	🔗
6	Mounting accessories TA/TB/TC	Cast iron	🔗
7	Accessories Y+PIN	Cast iron / *1	🔗
8	Accessories YS (Y+Floating pin)	Carbon steel	🔗

No.	Accessories	Material	Page link
9	Accessories I+PIN	Carbon steel	🔗
10	Floating joint MFC	Carbon steel	🔗
11	Floating joint MFCS	Carbon steel	🔗
12	Female rod ends PHS	Carbon steel	🔗
13	Fitting PC (PISCO)	—	🔗
14	Speed controller JSC (PISCO)	—	🔗
15	Cylinder link seats MVSN-300-C *3	Aluminum alloy	🔗
16	Solenoid valve MVSN-220 / 300 *3	—	🔗 , 🔗
17	Sensor switch R*T	—	🔗
18	Sensor switch RCI	—	🔗

*1. PIN material is carbon steel. *2. Bronze alloy.
*3. Only for tube I.D. ø40.

MCKQI3 Inside structure & Parts list / Dimensions



ISO 15552 **STANDARD PROFILE CYLINDER WITH NON-ROTATING ROD**

mindman

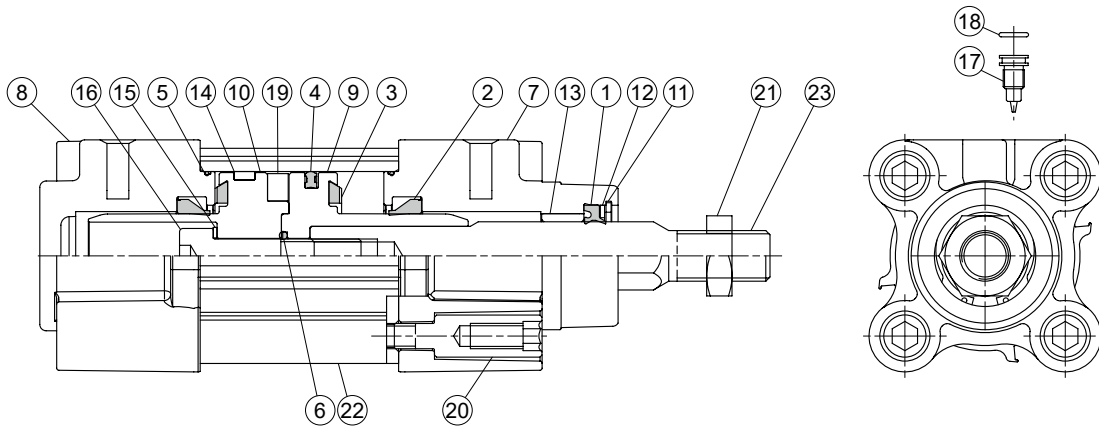

Material

No.	Part name	Material	Q'y	Component parts (inclusion)	Repair kits (inclusion)
1	Rod packing	NBR	1	●	●
2	Cushion packing	NBR	2	●	●
3	Cushion pad	NBR	2	●	●
4	Piston packing	NBR	1	●	●
5	O-ring	NBR	2	●	●
6	O-ring	NBR	1	●	●
7	Rod cover	Aluminum alloy	1	●	
8	Head cover	Aluminum alloy	1	●	
9	Piston-R	Aluminum alloy	1	●	
10	Piston-H	Aluminum alloy	1	●	
11	Snap ring	Spring steel	1	●	
12	Washer	Carbon steel	1	●	
13	Bush	Bearing alloy	1	●	
14	Wear ring	Resin	1	●	
15	Washer	Carbon steel	1	●*	
16	Bolt	Carbon steel	1	●	
17	Needle valve	Copper alloy	2	●	
18	O-ring	NBR	2	●	
19	Magnet ring	Magnet material	1	●	
20	Screw	Carbon steel	8	●	
21	Rod nut	Carbon steel	1	●	
22	Cylinder tube	Aluminum alloy	1		
23	Piston rod	Stainless steel	1		

* Only for ø40.

Order example of component parts

CP – MCKQI3 – □ – 40 M

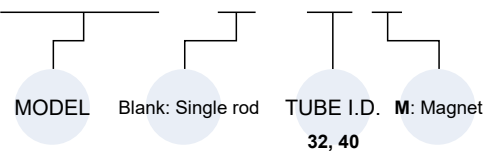

* Rc or NPT thread are also available, please contact us.

Order example of repair kits

PS – MCKQI3 – □ – 40

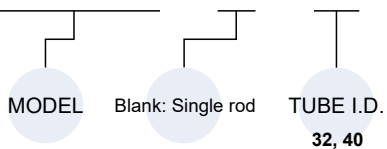

Dimensions

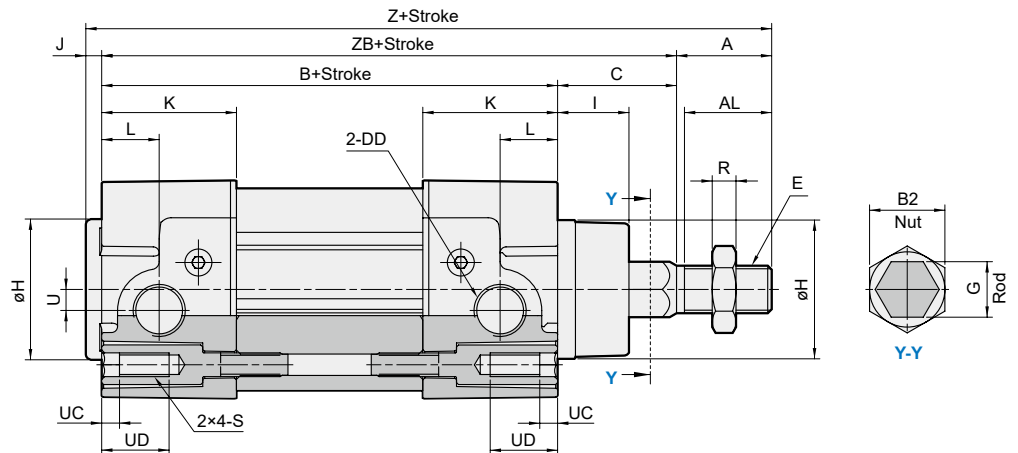
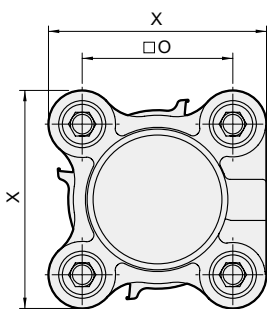

Code Tube I.D.	A	AL	B	B2	C	DD	E	G	H	I	J	K	L	O	R	S	U	UC	UD	X	Z	ZB
32	22	19.5	94	17	26	G1/8	M10×1.25	12	30	15	4	30.5	20	32.5	5	M6×1.0	4.5	4.5	16	47	146	120
40	24	22	105	19	30	G1/4	M12×1.25	14	35	18	4	34	14.5	38	6	M6×1.0	5.3	4.5	16	55	163	135



Locking unit



Technical data



Caution for safety
(Read before installing)

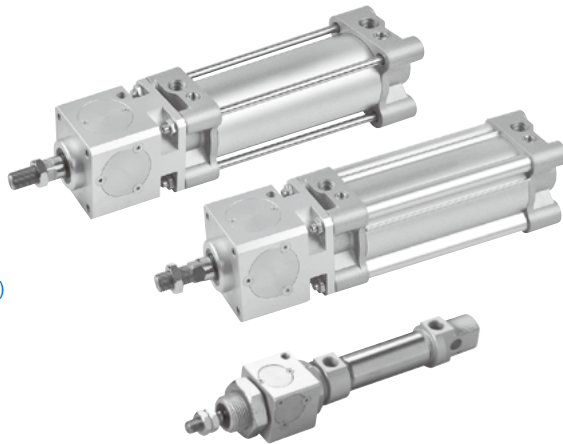

Table for standard stroke

Tube I.D.	Stroke (mm)	Max. stroke (mm)
ø20,25	10,25,50,75,100,125,150,200,300,400,500	800
ø32,40	50,75,100,125,150,175,200,250,300,350,400,450,500	1600
ø50,63		1800
ø80,100		2300
ø125		1800

* Intermediate stroke are available, please contact us.

Order example

MCBQV3 – 11 – 40 – 100M – S

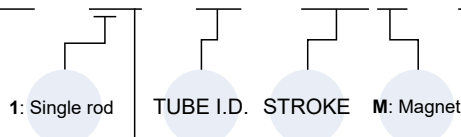

STYLE

Code	Symbol	Description
1 1		Double acting / Male thread

MODEL

MODEL	Tube I.D.	Blank: Cushion pad	A: Cushion air (Adjustable)
MCBBI	ø20, ø25	●	●
MODEL	Tube I.D.	Blank: Cushion air (Adjustable)	S: Cushion air (Automatic)
MCBQV3	ø32~ø100	●	●
MCBQI3	ø32~ø100	●	●
MCBQV	ø125	●	

CUSHION TYPE

* Rc or NPT thread are also available, please contact us.

Features

Multi-specification

MCB unit is applicable in 9 different bore sizes (ø20~125), piston rod can be locked at any position within the stroke range.

Brake function

Brake function is applicable in both directions.

Non lubrication

No lubricant is required for the piston rod. Utilize oil-containing alloys and special bearing bush to eliminate the necessity of lubrication on piston rod.

High quality long service life

Hard anodized aluminum tube and stainless steel tube allows cylinder to have better corrosion and abrasion resistance.

ISO 15552 & ISO 6432 standard specification

Conform to ISO 15552 & ISO 6432 standards. Unified design, most parts and mounting accessories are interchangeable.

Cylinder mountings

Variety of mounting accessories are available for different applications.

Specification

Model	MCBBI		MCBQI3					
	20	25	32	40	50	63	80	100
Tube I.D. (mm)								
Medium	Air							
Operating perssure range	0.3~0.6 MPa							
Proof pressure	1.5 MPa							
Ambient temperature	-5~+60°C (No freezing)							
Min. working pressure	0.3 MPa							
Available speed range	50~750		50~500 mm/sec					
Locking mode	Secure locking of piston rod in any position							
Lock retention forces (N)	490	490	790	1240	1930	3060	5400	7700
Sensor switch	RDC,RQC RDT,RQT RCM		RDT, RQT, RCI					
Sensor switch band	R*C/R*T	BKC-1/BKT-1	-					
	RCM	BM20	BM25	-				

* BKC-1 is not for R*CV vertical cable.

Model	MCBQV3						MCBQV
	32	40	50	63	80	100	125
Tube I.D. (mm)							
Medium	Air						
Operating perssure range	0.3~0.6 MPa						
Proof pressure	1.5 MPa						
Ambient temperature	-5~+60°C (No freezing)						
Min. working pressure	0.3 MPa						
Available speed range	50~500 mm/sec						
Locking mode	Secure locking of piston rod in any position						
Lock retention forces (N)	790	1240	1930	3060	5400	7700	12040
Sensor switch	RDC(V), RQC(V), RDT, RQT, RCA						
Sensor switch holder	R*C(V)	DT7-1		DT7-2		DT7-3	
	R*T	DT-1		DT-2		DT-3	
	RCA	HV1	HV2		HV3		HV4

ROD LOCKING CYLINDER

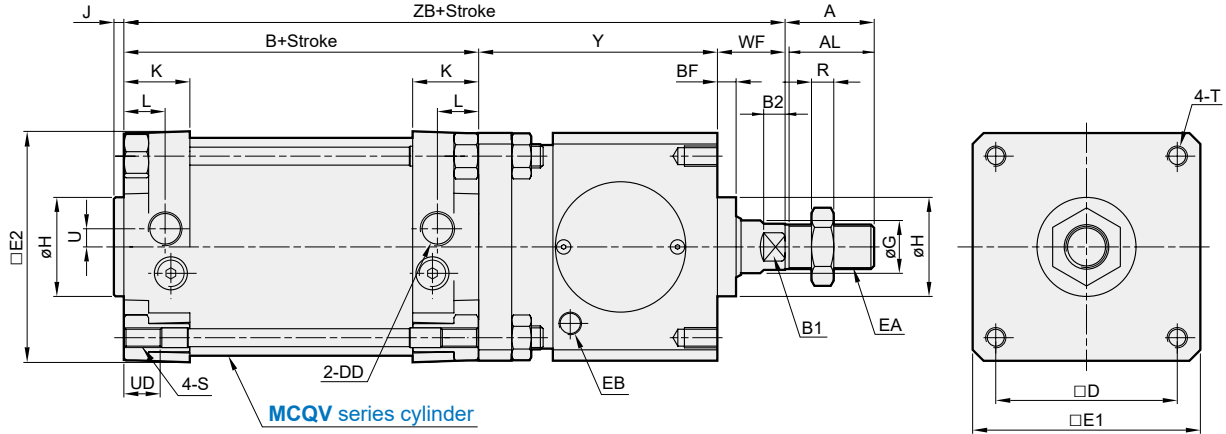

MCBQV













Code Tube I.D.	A	AL	B	B1	B2	BF	D	DD	E1	E2	EA	EB	G	H	J	K	L	R	S	T	U	UD	WF	Y	ZB
125	54	52	160	27	13	16	110	G1/2	138	140	M27×2.0	G1/4	32	60	6	40	25	13.5	M12×1.75	M12×20L	11	22	65	140	365



Cylinder weight

Unit: kg

Model	Basic weight (magnet) MCBMI-11	Stroke 25 mm MCBMI-11
Tube I.D.		
ø20	0.422	0.028
ø25	0.758	0.050

Model	Basic weight MCBQV3-11	Basic weight (magnet) MCBQV3-11	Basic weight MCBQV3-11-S	Basic weight (magnet) MCBQV3-11-S	Stroke 25 mm MCBQV3-11(-S)
Tube I.D.					
ø32	0.960	0.966	0.9	0.906	0.050
ø40	1.417	1.429	1.397	1.409	0.068
ø50	2.414	2.431	2.401	2.418	0.108
ø63	3.389	3.409	3.373	3.393	0.125
ø80	5.434	5.461	5.415	5.442	0.187
ø100	7.552	7.587	7.483	7.518	0.210

Model	Basic weight MCBQI3-11	Basic weight (magnet) MCBQI3-11	Basic weight MCBQI3-11-S	Basic weight (magnet) MCBQI3-11-S	Stroke 25 mm MCBQI3-11(-S)
Tube I.D.					
ø32	0.984	0.99	0.981	0.987	0.062
ø40	1.489	1.501	1.483	1.495	0.088
ø50	2.6	2.617	2.593	2.61	0.120
ø63	3.485	3.505	3.474	3.494	0.129
ø80	5.623	5.65	5.608	5.635	0.185
ø100	7.819	7.854	7.755	7.79	0.236

Model	Basic weight MCBQV-11	Basic weight (magnet) MCBQV-11	Stroke 25 mm MCBQV-11
Tube I.D.			
ø125	13.845	13.888	0.372



With cylinder



Technical data



Caution for safety
(Read before installing)



Features

- Locking unit is a mechanical device to apply to cylinders ISO 15552 and ISO 6432 whose scope is to block cylinder's rod in any position. This solution allows to block the race of the cylinder anytime takes place an unexpected fall of pressure.
- The blocking force is always and however greater of the one developed from the respective cylinder at 1 MPa.

Specification

Model	MCB									
Tube I.D. (mm)	20	25	32	40	50	63	80	100	125	
Rod diameter (mm)	8	10	12	16	20	20	25	25	32	
Medium	Air									
Operating pressure range	0.3~0.6 MPa									
Proof pressure	1.5 MPa									
Ambient temperature	-5~+80°C (No freezing)									
Min. working pressure	0.3 MPa									
Locking mode	Secure locking of piston rod in any position									
Lock retention forces (N) Max. static loading- Horizontal mounting	490	490	790	1240	1930	3060	5400	7700	12040	
Weight (kg)	0.19	0.19	0.40	0.60	1.10	1.50	2.60	3.50	6.50	

Order example

MCB – 40

MODEL

TUBE I.D.

Other examples of locking unit applications

For slides

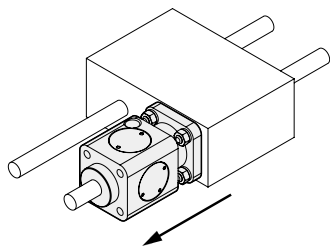

For piling

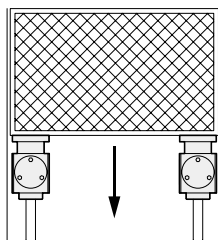

Chromium-plated shaft

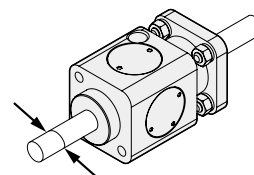

Tolerance	f7
Rod diameter	8,10,12,16,20,25,32

LOCKING UNIT

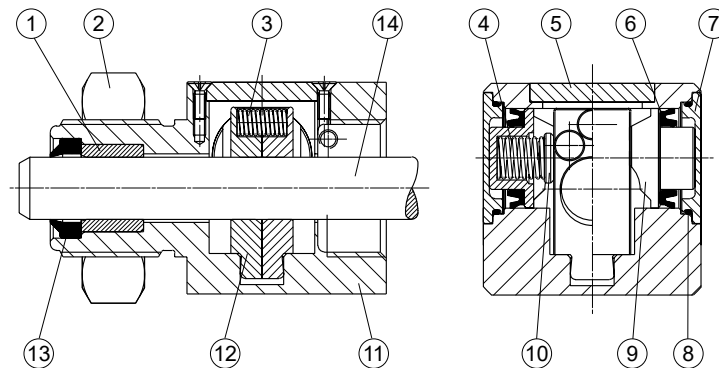

Attention

- Locking unit functioning is static type (cylinder's rod stopped).
- Before using the brake, take care to stop cylinder's rod.

Assemble attention

- Unlocking the locking unit by supplying air to the ⑩ body of locking unit. Please don't take out the ⑭ support pin after unlocking the locking unit.
- Using piston rod to push the ⑭ support pin off until the piston rod replaces the position of the ⑭ support pin. Finally you can lock the piston rod by removing the air supply.

* When the ⑩ body of locking unit is removed the air supply, if there is no ⑭ support pin or piston rod to support inside structure, it will cause the ⑭ jaws deviation. The piston rod can't be mounted anymore.

Material

No.	Part name	Material
1	Guida bush	Igolidur
2	Nut	Steel
3	Spring	Steel
4	Spring	Steel
5	Superior cover	Aluminum alloy
6	Seal piston	NBR
7	Lateral cover	Aluminum alloy
8	O-ring	NBR
9	Piston	Delrin
10	Spring cover	Delrin
11	Body	Aluminum alloy
12	Jaws	Bronze
13	Rod seal	NBR
14	Support pin	Carbon steel

Connection scheme

Pneumatic control

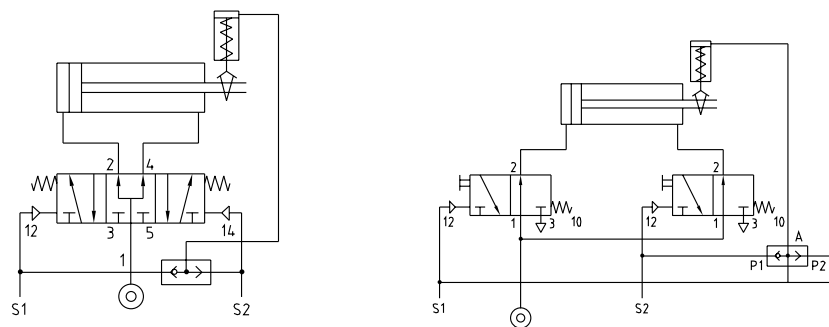

Electropneumatic control

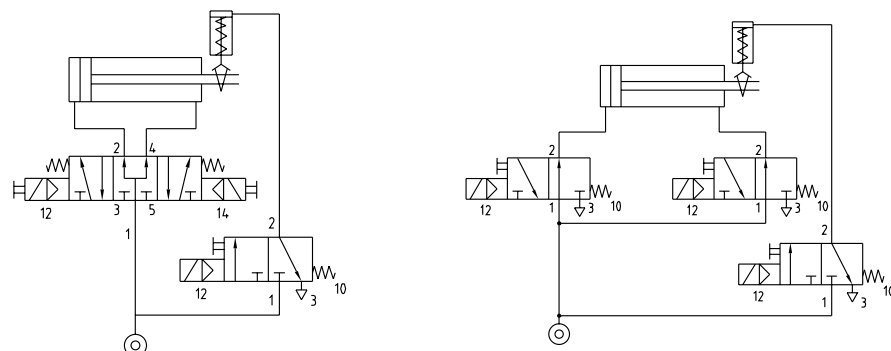

LOCKING UNIT

$\phi 20, \phi 25$

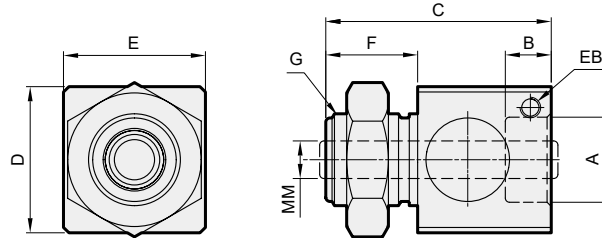

Code Tube I.D.	A	B	C	D	E	EB	F	G	MM
20	M22×1.5	11	54	35	34	M5	22	M22×1.5	$\phi 8^{T7}$
25	M22×1.5	11	54	35	34	M5	22	M22×1.5	$\phi 10^{T7}$

$\phi 32 \sim \phi 125$

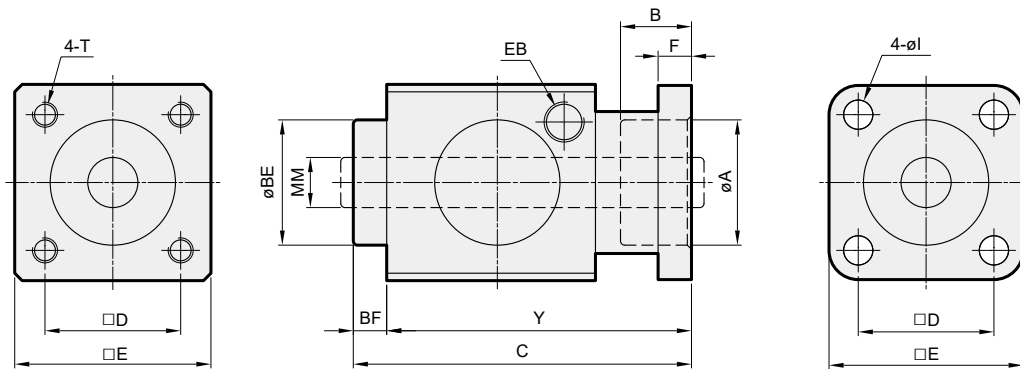

Code Tube I.D.	A	B	BE	BF	C	D	E	F	EB	I	MM	T	Y
32	30.5	20.5	30	7.5	67.5	32.5	47	6	G1/8	6.5	$\phi 12^{T7}$	M6×8L	60
40	35.5	22.5	34.9	10	80	38	54	6	G1/8	6.5	$\phi 16^{T7}$	M6×8L	70
50	40.5	29	40	10	100	46.5	65	8	G1/8	9	$\phi 20^{T7}$	M8×12L	90
63	45.5	29	45	10	100	56.5	75	8	G1/8	9	$\phi 20^{T7}$	M8×12L	90
80	45.5	37	45	10	120	72	95	12	G1/4	11	$\phi 25^{T7}$	M10×16L	110
100	55.5	39	55	10	120	89	114	12	G1/4	11	$\phi 25^{T7}$	M10×16L	110
125	60.5	51.5	60	16	156	110	138	20	G1/4	13	$\phi 32^{T7}$	M12×20L	140



Technical data



Caution for safety
(Read before installing)

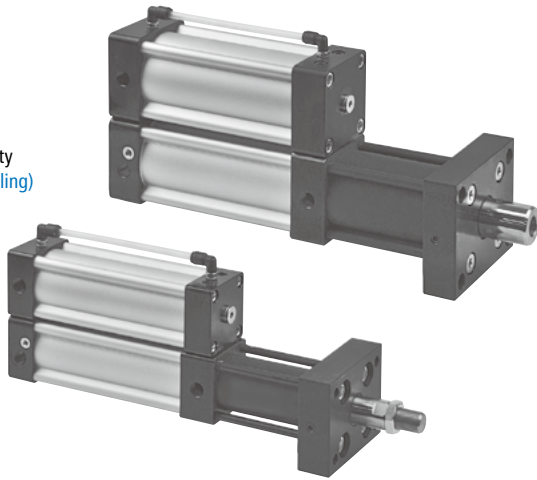

Features

- Hydro-pneumatic solution provides high power in confined space.
- Simple construction make these units ideal in many applications where previously hydraulics were the only option.
- Quiet in operation.
- Only requires a pneumatic valve to make the system operate.
- Wide range of working strokes and output forces available.

Specification

Model	MHPD
Pressure boost model	1T, 3T, 5T, 8T, 10T
Total stroke (mm)	50, 75, 100, 150, 200
Working stroke (mm)	5, 10, 15, 20
Medium	Filtered air with or without lubrication
Operating pressure range	0.3 ~ 0.8 MPa
Ambient temperature	-10~+60 °C (No freezing)

MHPD

Hole in rod end type



MHPD-Z

Male thread in rod end type

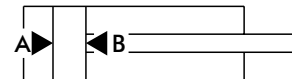

Order example

MHPD — 3T × 100 — 10 — Z

MODEL

THRUST MODEL

1T
3T
5T
8T
10T

TOTAL STROKE

50: 50mm
75: 75mm
100: 100mm
150: 150mm
200: 200mm

WORKING STROKE

5: 5mm
10: 10mm
15: 15mm
20: 20mm

ROD END TYPE



Blank: Hole



Z: Male thread

Power cylinders theoretic force

Unit: N

Thrust model		1T	3T	5T	8T	10T	
Tube I.D. (mm)		ø50	ø70	ø80	ø100	ø125	
Rod (mm)		ø30	ø40	ø50	ø60	ø70	
Operating pressure (MPa)	0.3	A	7,216	18,473	30,054	46,959	67,630
		B	377	778	919	1,508	2,527
	0.4	A	9,621	24,630	40,072	62,612	90,174
		B	503	1,037	1,225	2,011	3,369
	0.5	A	12,026	30,788	50,090	78,265	112,717
		B	628	1,296	1,532	2,513	4,212
	0.6	A	14,432	36,945	60,108	93,918	135,261
		B	754	1,555	1,838	3,016	5,054
	0.7	A	16,837	43,103	70,126	109,571	157,804
		B	880	1,814	2,144	3,519	5,896
	0.8	A	19,242	49,260	80,143	125,224	180,347
		B	1,005	2,073	2,450	4,021	6,739

1. Quick traverse

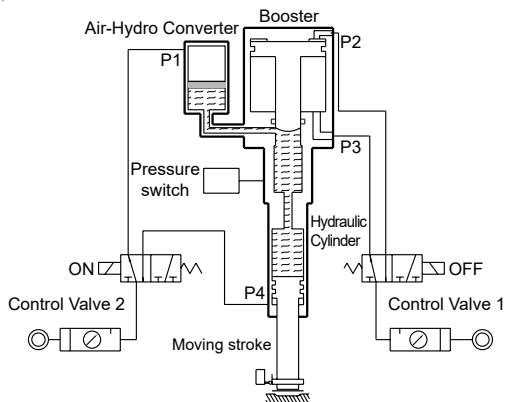

When the air is charged from the port P1, the oil in the tank will forward the hydraulic cylinder quickly. The pressure is the same as the air pressure, but the inflow of oil is large in volume.

2. Intensified feeding

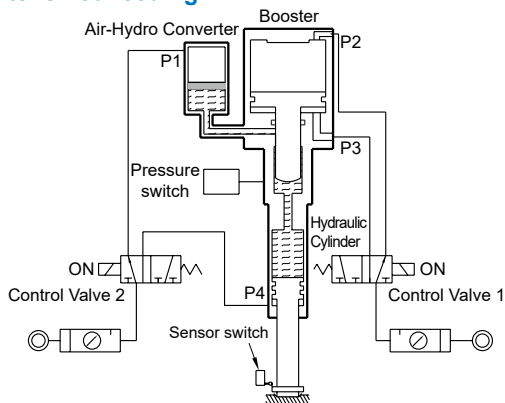

When the air is charged from the port P2, a ram will advance. the highly pressured fluid will come in to the hydraulic cylinder which will be forwarded by large thrust.

3. Swift reverse

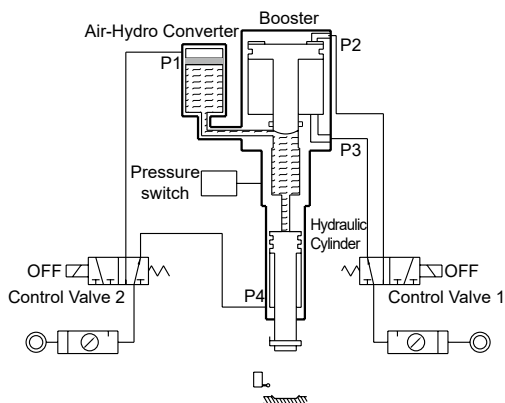

When the air is send into port P4 and P3. the hydraulic cylinder is swiftly reversed. and at the same time the ram goes back.

Points in usage

- The booster must be levelled. The booster must be higher than the work cylinder.
- Standard booster are designed for use with petroleum base hydraulic oil.
- Before working, the rod of booster and hydraulic must return.
- Frequency of use should be 20 times/min or lower.

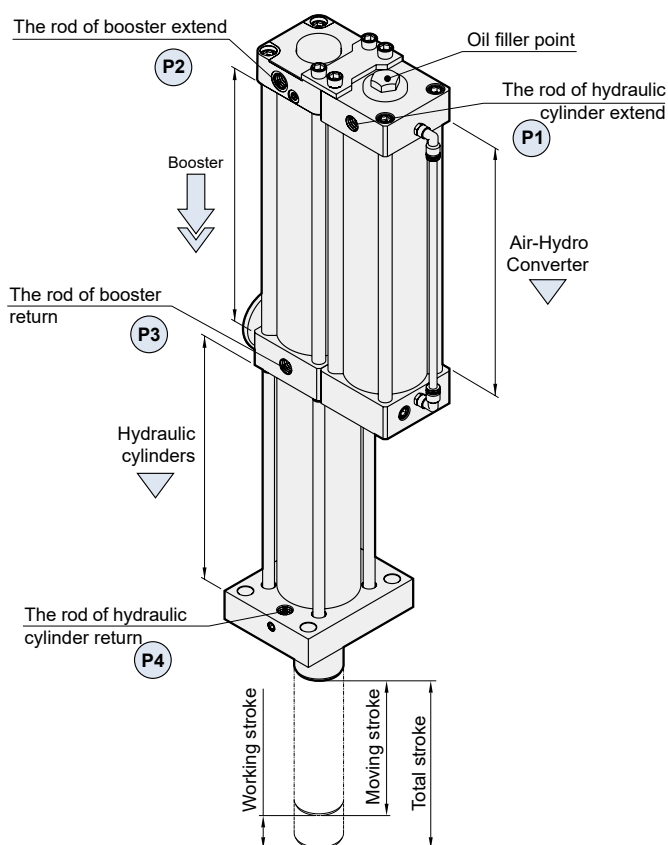

Power Cylinders bore and stroke

Type	Working stroke (mm)					
	1T	3T	5T	8T	10T	
MHPD	50mm	⑤⑩⑮	⑤⑩	⑤⑩	⑤⑩	⑤⑩⑮
	75mm	⑤⑩⑮⑳	⑤⑩⑮	⑤⑩⑮	⑤⑩⑮	⑤⑩⑮
	100mm	⑤⑩⑮⑳	⑤⑩⑮	⑤⑩⑮	⑤⑩⑮	⑤⑩⑮
	125mm	⑤⑩⑮⑳	⑩⑮	⑤⑩⑮	⑩⑮	⑩⑮⑳
	150mm	⑩⑮⑳	⑩⑮⑳	⑩⑮⑳	⑩⑮⑳	⑩⑮⑳
	200mm	⑩⑮⑳	⑩⑮⑳	⑩⑮⑳	⑩⑮⑳	⑩⑮⑳
MHPD-Z	50mm	⑤⑩⑮	⑤⑩	⑤⑩⑮	⑤⑩⑮	⑤⑩⑮
	75mm	⑤⑩⑮⑳	⑤⑩⑮	⑤⑩⑮	⑤⑩⑮	⑤⑩⑮⑳
	100mm	⑤⑩⑮⑳	⑤⑩⑮⑳	⑤⑩⑮	⑤⑩⑮⑳	⑤⑩⑮⑳
	125mm	⑤⑩⑮⑳	⑩⑮⑳	⑤⑩⑮⑳	⑩⑮⑳	⑩⑮⑳
	150mm	⑩⑮⑳	⑩⑮⑳	⑩⑮⑳	⑩⑮⑳	⑩⑮⑳
	200mm	⑩⑮⑳	⑩⑮⑳	⑩⑮⑳	⑩⑮⑳	⑩⑮⑳

Note. ⑤ = Working stroke 5mm, ⑩ = Working stroke 10mm;
⑮ = Working stroke 15mm, ⑳ = Working stroke 20mm;
Short stroke: ⑤⑩⑮⑳, Long stroke: ⑤⑩⑮⑳

MHPD / MHPD-Z

Standard stroke (Short stroke)

Type	Working stroke			
	5	10	15	20
1T	50~75	50~125	50~150	75~200
3T	50	50~100	75~150	150~200
5T	50~75	50~150	75~200	150~200
8T	50~75	50~150	75~200	150~200
10T	50	50~125	50~200	125~200
1T-Z	50~75	50~125	50~150	50~200
3T-Z	50	50~100	75~150	100~200
5T-Z	50~75	50~150	50~200	125~200
8T-Z	50~75	50~150	50~200	100~200
10T-Z	50	50~125	50~200	75~200

Working stroke

Type	W			
	5	10	15	20
1T	108	146	184	222
3T	126	187	248	309
5T	135	199	263	327
8T	150	214	278	342
10T	148	212	276	340

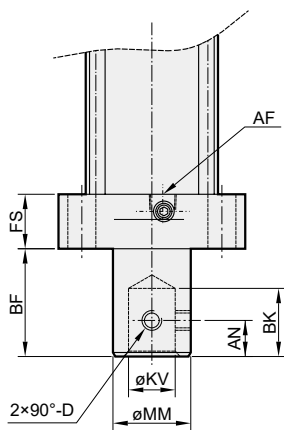

Female thread

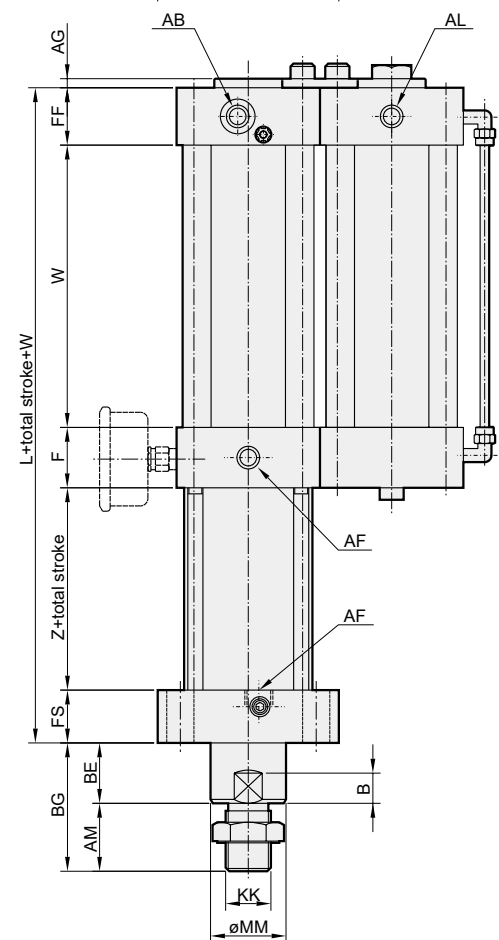
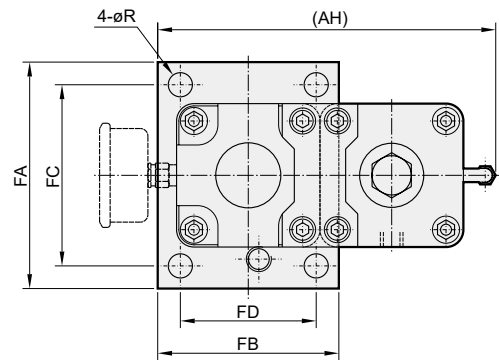
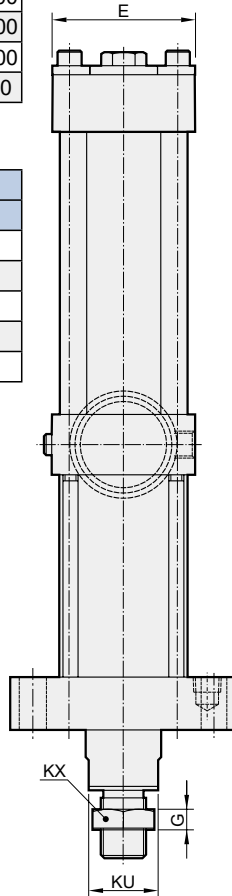

Code Type	AB	AF	AG	AH	AL	AM	AN	B	BE	BF	BG	BK	D	E	F
1T	G3/8	G3/8	5	187	G3/8	35	12	12	25	40	60	28	M6×1.0	75	40
3T	G3/8	G3/8	6	227	G3/8	45	15	20	40	50	85	35	M6×1.0	95	40
5T	G1/2	G1/2	6	262	G1/2	60	20	20	40	60	100	40	M10×1.5	115	40
8T	G1/2	G1/2	6	315	G1/2	70	25	20	50	70	120	60	M10×1.5	140	45
10T	G3/4	G3/4	6	381	G3/4	80	30	27	60	85	140	50	M10×1.5	174	55

Code Type	FA	FB	FC	FD	FF	FS	G	KK	KU	KV	KX	L	MM	R	Z
1T	130	100	100	70	32	35	11	M22×1.5	27	16	32	167	30	11	60
3T	150	120	120	90	38	35	13	M30×1.5	36	20	41	187	40	16	74
5T	185	130	155	100	40	45	15	M40×2.0	46	25	57	199	50	17	74
8T	230	160	190	120	45	45	15	M48×2.0	55	30	65	218	60	22	83
10T	270	190	220	140	55	50	20	M56×2.0	65	40	80	243	70	26	83

MHPD / MHPD-Z

Standard stroke (Long stroke)

Type	Working stroke		
	5	10	15
1T	80~125	130~200	155~200
3T	55~100	105~200	155~200
5T	80~125	155~200	–
8T	80~100	155~200	–
10T	75~100	130~200	–
1T-Z	80~125	130~200	155~200
3T-Z	55~100	105~200	155~200
5T-Z	80~125	155~200	–
8T-Z	80~100	155~200	–
10T-Z	55~100	130~200	–

Type	W		
	5	10	15
1T	108	146	184
3T	126	187	248
5T	135	199	263
8T	150	214	278
10T	148	212	276

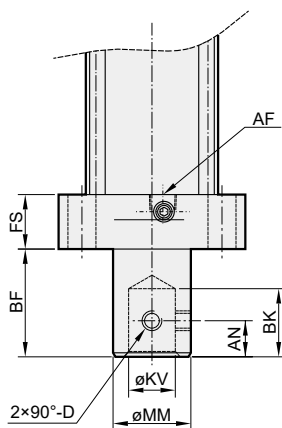

Female thread

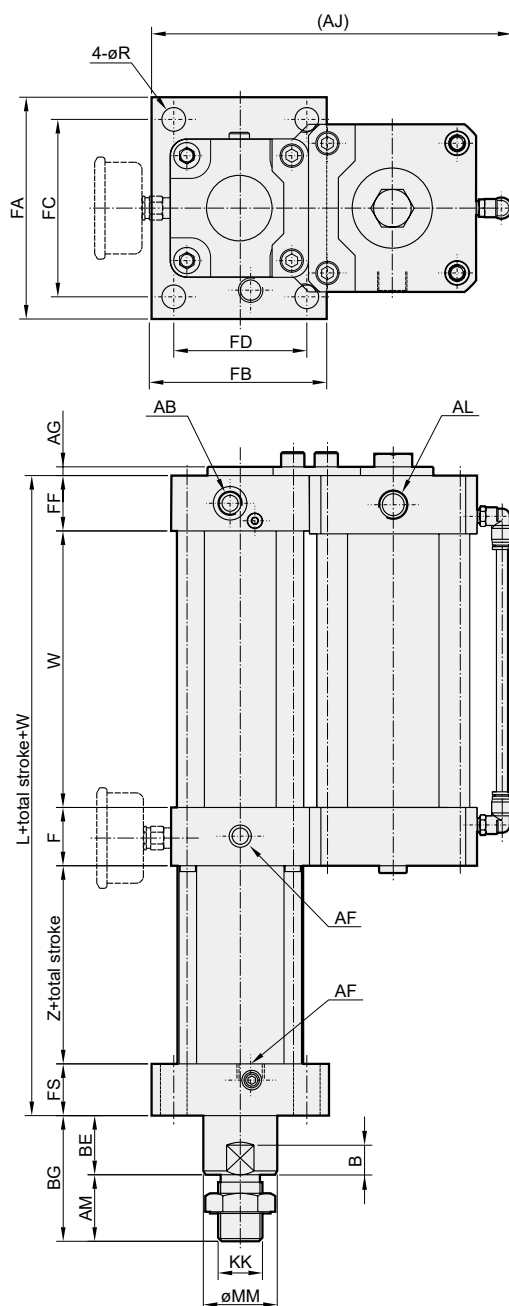
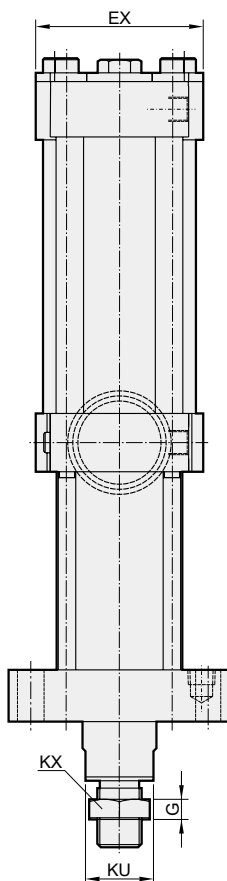

Code Type	AB	AF	AG	AJ	AL	AM	AN	B	BE	BF	BG	BK	D	EX	F
1T	G3/8	G3/8	5	207	G3/8	35	12	12	25	40	60	28	M6×1.0	95	40
3T	G3/8	G3/8	6	247	G1/2	45	15	20	40	50	85	35	M6×1.0	115	40
5T	G1/2	G1/2	6	287	G1/2	60	20	20	40	60	100	40	M10×1.5	140	40
8T	G1/2	G1/2	6	341	G3/4	70	25	20	50	70	120	60	M10×1.5	174	45
10T	G3/4	G3/4	6	411	G3/4	80	30	27	60	85	140	50	M10×1.5	204	55

Code Type	FA	FB	FC	FD	FF	FS	G	KK	KU	KV	KX	L	MM	R	Z
1T	130	100	100	70	32	35	11	M22×1.5	27	16	32	167	30	11	60
3T	150	120	120	90	38	35	13	M30×1.5	36	20	41	187	40	16	74
5T	185	130	155	100	40	45	15	M40×2.0	46	25	57	199	50	17	74
8T	230	160	190	120	45	45	15	M48×2.0	55	30	65	218	60	22	83
10T	270	190	220	140	55	50	20	M56×2.0	65	40	80	243	70	26	83

