

AIR TREATMENT UNIT

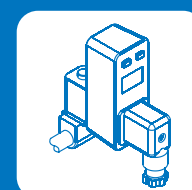
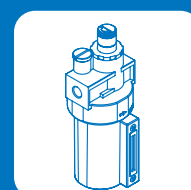
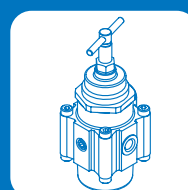
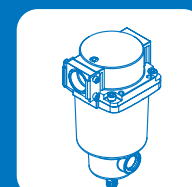
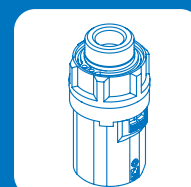
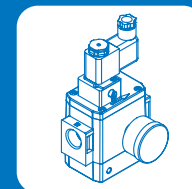
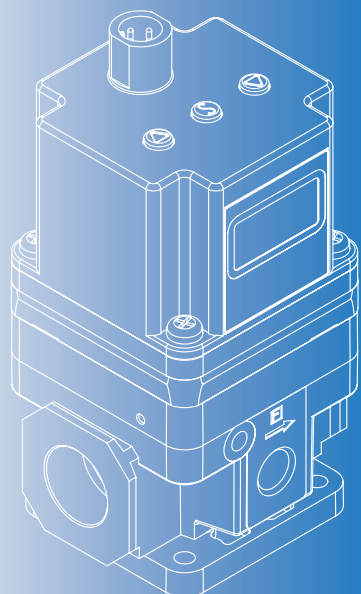

	ELECTRO PNEUMATIC REGULATOR	
MAER	Features	4-86
	Precautions	4-87
	MAER200	4-90
	MAER210	4-94
	MAER300	4-98
	MAER310	4-102
	PRECISION REGULATOR	
MAIR	Features	4-106
	Precautions	4-107
	MAIR100	4-108
	MAIR200	4-110
	MAIR300	4-112
	LUBRICATOR	
MAL	MAL200 / 200L	4-114
	MAL302	4-115
	MAL400	4-116
	MAL401	4-117
	MAL403	4-118
	MAL501	4-119
	MAL900	4-120
	FLOAT SWITCH (for L.UNIT)	
MLF	MLF300/400	4-121
	AIR / MIST / MICRO MIST FILTER	
MA*	Selector Table	4-122

	MAF200D/M	4-123
	MAF200LD/M	4-123
	MAF302D/M	4-124
	MAF401A/D/M	4-126
	MAFF401AD/DM	4-128
	MAFRF401	4-129
	MATFR401	4-130
	MAF403A/D/M	4-131
	MAF501D/M	4-133
MAM*	Features	4-136
	MAMG25/35/45/55	4-140
	MAMB25/35/45/55	4-142
	MAMD25/35/45/55	4-144
	MAMM25/35/45/55	4-146
	MAMF25/35/45/55	4-148
	SOFT START-UP VALVE	
MAVS	MAVS	4-152
	HIGH EFFICIENCY COMPRESSED AIR FILTER	
MJ*	MJF/MJL	4-156
	DIGITAL CONDENSATION REMOVAL TIMER	
M**	MBS/MCS/MBD	4-159
	BOOSTER REGULATOR	
MVBA	4-160
MVBAT	with air tank	4-164
MHB*	MHBS / MHBD	4-166

Family

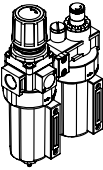
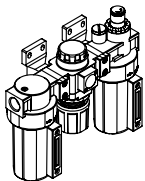
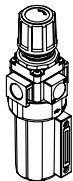
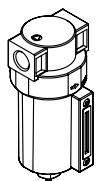
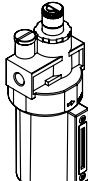
Model	MACP	MACT	MAFR	MAF	MAL
Pictures					
100			●		
200	●	●	●	●	●
200L	●	●	●	●	●
302	●	●	●	●	●
400	●	●	●	●	●
401	●	●	●	●	●
403	●	●	●	●	●
501	●	●	●	●	●
900				●	●
901				●	

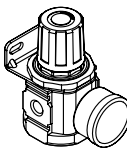
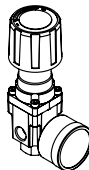
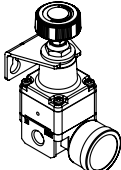
Model	MAR	MAHR	MAIR
Pictures			
100	●		●
200	●	●	●
300			●
302	●		
400	●		
401	●		
403	●		
501	●		
900	●		
901	●		

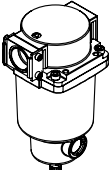
Model	MAM*
Pictures	
25	●
35	●
45	●
55	●

Selector table

● Standard type ◎ Option

Port size									Series	Drain type		
M5	6A	8A	10A	15A	20A	25A	40A	50A		Manual	Semi-automatic	Automatic
●									100		●	
	●	●							200		●	
	●	●							200L		●	
		●	●	●					302		●	◎
		●	●	●					400		●	◎
		●	●	●					401		●	◎
		●	●	●					403		●	◎
					●	●			501		●	◎
							●		900	●		◎
								●	901	●		◎
		●	●						25		●	◎
			●	●					35		●	◎
				●	●				45		●	◎
					●	●			55		●	◎

Selector table

● Standard type ◎ Option

MAR Regulation (Adjustable pressure)						Series	MAF / MAM* Filter (Filter element)							
1K	2K	3K	4K	8.5K	15K		0.01 μ	0.3 μ	3 μ	5 μ	20 μ	40 μ	50 μ	Water separator
				●		100			●		◎			
◎	◎	◎	◎	●		200	◎	◎	◎		●			
				●		200L	◎	◎	◎		●			
				●		302	◎	◎	●		◎		●	
				●		400			◎		●			
				●	◎	401	◎	◎	◎		●			
				●		403			◎		●			
				●		501	◎	◎			●			
				●		900						●		
				●		901						●		
						25	●	●	●				●	●
						35	●	●	●				●	●
						45	●	●	●				●	●
						55	●	●	●				●	●

MAHR / MAIR Regulation (Adjustable pressure)					Series
2K	4K	8K	10K	27K	
			●	◎	MAHR200
●	●	●			MAIR100
●	●	●			MAIR200
●	●	●			MAIR300

Bowl assembly (MAFR, MAF, MAFV series)

● Standard type ◎ Option

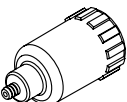
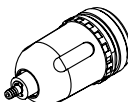
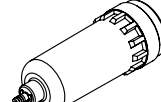
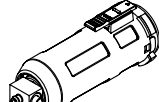
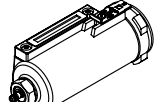
Series	100	200	200L	302	302
Fig					
Order example	BOWL-MAFR100	BOWL-MAF200-1 2	BOWL-MAF200L-1	BOWL-MAF302-1 2 3	BOWL-MAF302-M3
Applicable model	MAFR100	MAFR200, MAF200	MAFR200L, MAF200L	MAFR302, MAF302	MAFR302, MAF302
1 Bowl	PC	-	●	●	
	Metal	M		◎	●
	Nylon	N	◎	◎	
2 Bowl Guard	None	-	◎	◎	
	U		●	●	
3 Drain valve	-	●	●	●	●
	D2			◎	◎

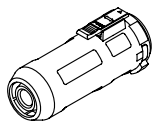
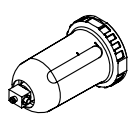
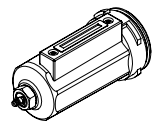
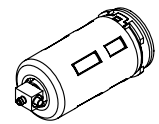
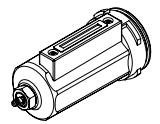
Series	302	400	401	403	501
Fig					
Order example	BOWL-MAFV302-NU	BOWL-MAF400-1 2 3	BOWL-MAF401(-W)-3	BOWL-MAF403-1 2 3	BOWL-MAF401-W-3
Applicable model	MAFV302	MAFR400, MAF400	MAFR401(-W), MAF401(-W)	MAFR403, MAF403	MAFR501-M, MAF501-M
1 Bowl	PC	-		●	
	Metal	M			●
	Nylon	N	◎		◎
2 Bowl Guard	None	-	◎	◎	
	U		●	●	
3 Drain valve	-		●	●	●
	D2		◎	◎	◎
	D3		◎	◎	◎
	D4		◎	◎	◎

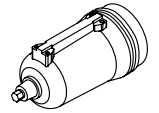
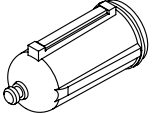
Series	900	901
Fig		
Order example	BOWL-MAF900-3	BOWL-MAF901-3
Applicable model	MAF900	MAF901
1 Bowl	PC	-
	Metal	M
	Nylon	N
2 Bowl Guard	None	-
	U	
3 Drain valve	-	●
	D2	
	D3	
	D4	
	D7	◎

Drain valve (for MAFR, MAF series)

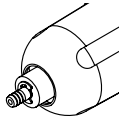
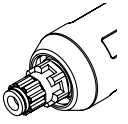
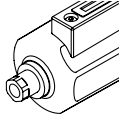
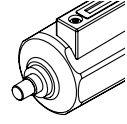
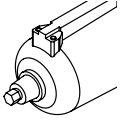
	Blank	D2
Fig		
Description	Semi-auto drain	
	D3	D4
Fig		
Description	MADV400-WA (Female thread)	MADV400-WB (Male thread)
		D7
		
		SN-2636-01

*Order example: **BOWL-MAF400-NUD2** (N: Nylon, U: Bowl guard, D2: Auto drain valve)

Bowl assembly (MAL series)

● Standard type ◎ Option

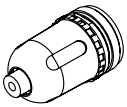
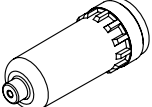
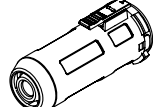
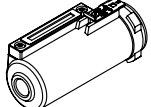
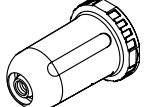
Series			200	200L	302	302	400
Fig							
Order example			BOWL-MAL200-¹²	BOWL-MAL200L-¹	BOWL-MAL302-¹²³	BOWL-MAL302-M³	BOWL-MAL400-¹²
Applicable model			MAL200	MAL200L	MAL302	MAL302-M	MAL400
¹ Bowl	PC	-	●	●	●		●
	Metal	M		◎	◎	●	
	Nylon	N	◎	◎	◎		◎
² Bowl Guard	None	-	◎		◎		◎
	Guard	U	●		●		●
³ Float switch	F1			◎		◎	

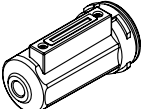
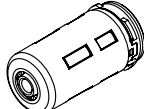
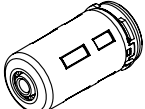
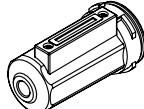
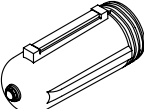
Series			401	403	501		900
Fig							
Order example			BOWL-MAL401(-W)-³	BOWL-MAL403-¹²³	BOWL-MAL403-¹²	BOWL-MAL401-W	BOWL-MAL900
Applicable model			MAL401(-W)	MAL403	MAL501	MAL501-M	MAL900
¹ Bowl	PC	-		●	●		
	Metal	M	●			●	●
	Nylon	N		◎	◎		
² Bowl Guard	None	-		◎	◎		
	Guard	U		●	●		
³ Float switch	F1		◎	◎			

*Order example: **BOWL-MAL302-NU** (N: Nylon, U: Bowl guard)

Bowl material (Caution for safety)

Effects of atmosphere of organic solvents and chemicals, and where these elements are likely to adhere to the equipment. Chemical data for substances causing degradation (Reference)

Type	Chemical name	Application examples	Material	
			Polycarbonate	Nylon
Acid	Hydrochloric acid, Chromic acid Sulfuric acid, Phosphoric acid	Acid washing liquid for metals	△	×
Alkaline	Sodium hydroxide (Caustic soda) Calcium hydroxide (Slack lime) Potash, Ammonia water Carbonate of soda	Degreasing of metals Industrial salts Water-soluble cutting oil	×	○
Inorganic salts	Sodium sulfide, Potassium nitrate Sulfate of soda	—	×	△
Chlorine solvents	Carbon tetrachloride, Chloroform Ethylene chloride, Methylene chloride	Cleansing liquid for metals Printing ink, Dilution	×	△
Aromatic series	Benzene, Toluene, Paint thinner	Coatings, Dry cleaning	×	△
Ketone	Acetone, Cyclohexane Methyl ethyl ketone	Photographic film Dry cleaning, Textile industries	×	×
Alcohol	Ethyl alcohol, IPA, Methyl alcohol	Anti-freeze, Adhesives	△	×
Oil	Gasoline, Kerosene	—	×	○
Ester	Dimethyl phthalate Diethyl phthalate, Acetic acid	Synthetic oil Anti-rust additives	×	○
Ether	Methyl ether, Ethyl ether	Brake oil additives	×	○
Amino	Methyl amino	Cutting oil, Brake oil additives Rubber accelerant	×	×
Others	Thread-lock fluid, Seawater, Leak tester	—	×	△

○ : Essentially safe △ : Some effects may occur. × : Effects will occur.

* When the above factors are present, or there is some doubt, use a metal bowl for safety.

MAL lubrication (Caution for safety)

When supplying lubrication, use class 1 turbine oil (with no additive) ISO VG32, or class 2 turbine oil ISO VG32 in the following table. Without continued lubrication during manufacturing, malfunctions could occur. If turbine oil is used, refer to the Material Safety Data sheet (SDS) of the turbine oil. (Reference)

Lubricant brands	Manufacturer	Viscosity Grades
Super turbine oil 32	Idemitsu Kosan	ISO VG32
Mobil DTE LIGHT	Exxon Mobil Corporation	ISO VG32
Mobil rarus 424	Exxon Mobil Corporation	ISO VG32
GII 32	Formosa Petrochemical Corporation	ISO VG32
Turbo T 32	Royal Dutch Shell	ISO VG32
R32	CPC Corporation	ISO VG32

* Do not add additives. This may affect the operation of the product.

* The name of the lubricant manufacturer and the lubricant brand may change. Please contact each of the companies for details.

Bracket

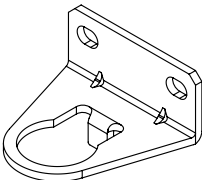
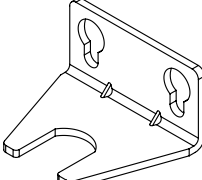
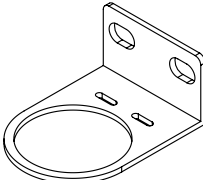
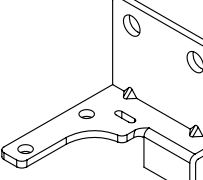
Order example	B1-MAR100	B1-MAIR100	B1-MAR200	B1-MAL200 (*)
Pictures				
Applicable model	MAR100, MAFR100	MAIR100	MACP200, MACT200 MAFR200, MAR200	MAL200

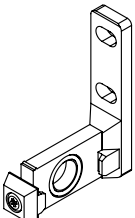
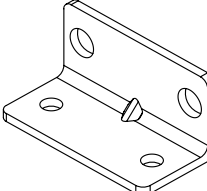
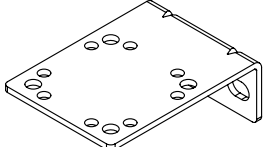
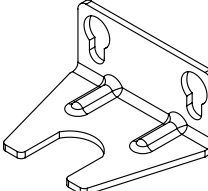
Order example	BL-MACP200	B1-MAF200	B1-MAER200	B1-MAIR200
Pictures				
Applicable model	MACP200, MACT200	MAF200	MAER200, MAER210 MAER300, MAER310	MAIR200

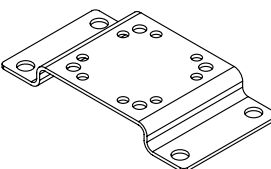
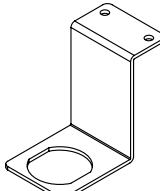
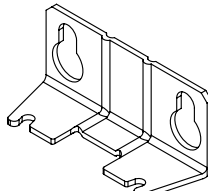
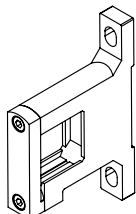
Order example	B2-MAER200	B3-MAR200	B1-MAIR300	BT-MACP302
Pictures				
Applicable model	MAER200, MAER210 MAER300, MAER310	MAFR200, MAR200	MAIR300	MACP302, MACT302 MAIR200, MAER200

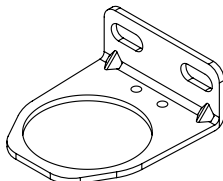
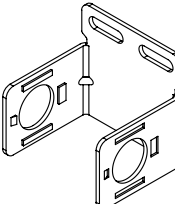
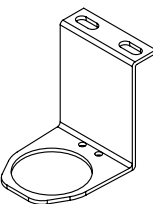
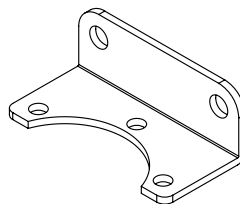
Order example	B1-MAR302	B2-MAF302	B3-MAR302	B1-MAR400
Pictures				
Applicable model	MAFR302, MAR302 MARV302	MAL302, MAF302 MAFV302	MAFR302, MAR302	MACP400, MACT400 MAFR400, MAR400

* For order **B1-MAL200**, please note that the body needs to have fixed threaded holes collocating with bracket.

Bracket

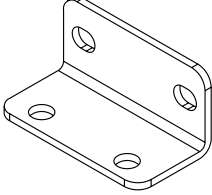
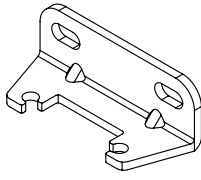
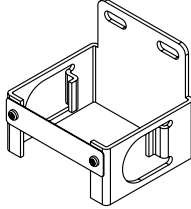
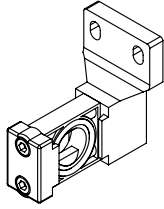
Order example	B1-MAF400	B2-MAR401	B2-MAF401	BL-MACP401
Pictures				
Applicable model	MAF400, MAL400	MAFR401, MAR401 MAFR403, MAR403	MAF401, MAL401 MAF403, MAL403	MACP401, MACT401

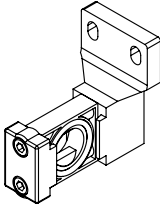
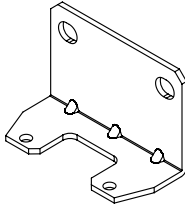
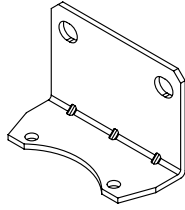
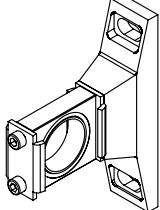
Order example	BL-MACP403	B1-MAR501	B1-MAF501	BT-MACP501
Pictures				
Applicable model	MACP401-W, MACT401-W MACP403, MACT403, MAIR300	MAR501, MAFR501	MAF501, MAL501	MACP501, MACT501

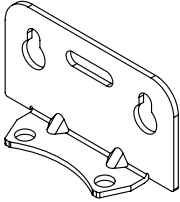
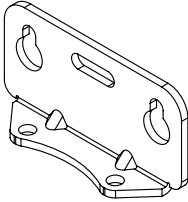
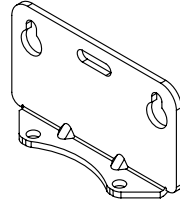
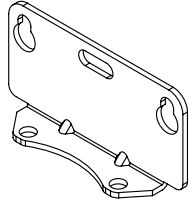
Order example	B1-MAMG25	B1-MAMG35	B1-MAMG45	B1-MAMG55
Pictures				
Applicable model	MAM*25	MAM*35	MAM*45	MAM*55

Joiner set

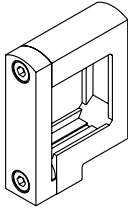
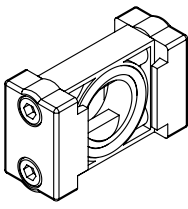
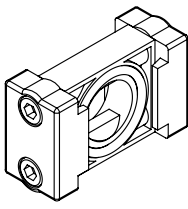
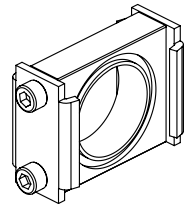
Order example	BS-MACP302	BS-MACP401	BS-MACP403	BS-MACP501
Pictures				
Applicable model	MACP302, MACT302 MAIR200, MAER200	MACP401, MACT401	MACP401-W, MACT401-W MACP403, MACT403, MAM*25, MAM*35	MACP501, MACT501 MAM*45, MAM*55

Gauge adapter set *Order example: A-MAR302-NPT

● Standard type ○ Option

	Applicable model	Order example	Port thread	
			—	NPT
			Rc thread	NPT thread
MAR302, MAFR302	A-MAR302 —□	●	○	
MAR401, MAFR401	A-MAR401 —□	●	○	
MAR401-W, MAFR401-W MAR403, MAFR403 MAR501, MAFR501	A-MAR302 —□ (Shared with 302)	●	○	

* Recommended tightening torque is between 1.5 to 2.5 Nm for the female thread (1/8") and 0.3 to 0.5Nm for the screws(M2.6).

T type module mounting bracket *Order example : T8-MACP302-G

● Standard type ○ Option

	Applicable model	Order example	Port size		Port thread	
			T8,T10	T15	—	G, NPT
			1/4, 3/8	1/2	Rc thread	G,NPT thread
MACP302, MACT302	T8/T10/T15-MACP302 —□	○	○	●	○	
MACP401, MACT401	T8/T10/T15-MACP401 —□	○	○	●	○	
MACP401-W, MACT401-W MACP403, MACT403	T8/T10/T15-MACP403 —□					
MACP501, MACT501	T8/T10/T15-MACP501 —□	○	○	●	○	
MAM*25, MAM*35	T8/T10/T15-MAMG25 —□	○	○	●	○	
MAM*45, MAM*55	T8/T10/T15-MAMG45 —□	○	○	●	○	

Check valve *Order example : K8-MACP401-G

● Standard type ○ Option

	Applicable model	Order example	Port size	Port thread	
			K8,K10	—	G, NPT
			1/4, 3/8	Rc thread	G,NPT thread
MACP302, MACT302	K8/K10-MACP302 —□	○	●	○	
MACP401, MACT401	K8/K10-MACP401 —□				
MACP401-W, MACT401-W MACP403, MACT403	K8/K10-MACP403 —□				
MAM*25, MAM*35	K8/K10-MAMG25 —□	○	●	○	

MEMO

NOTE

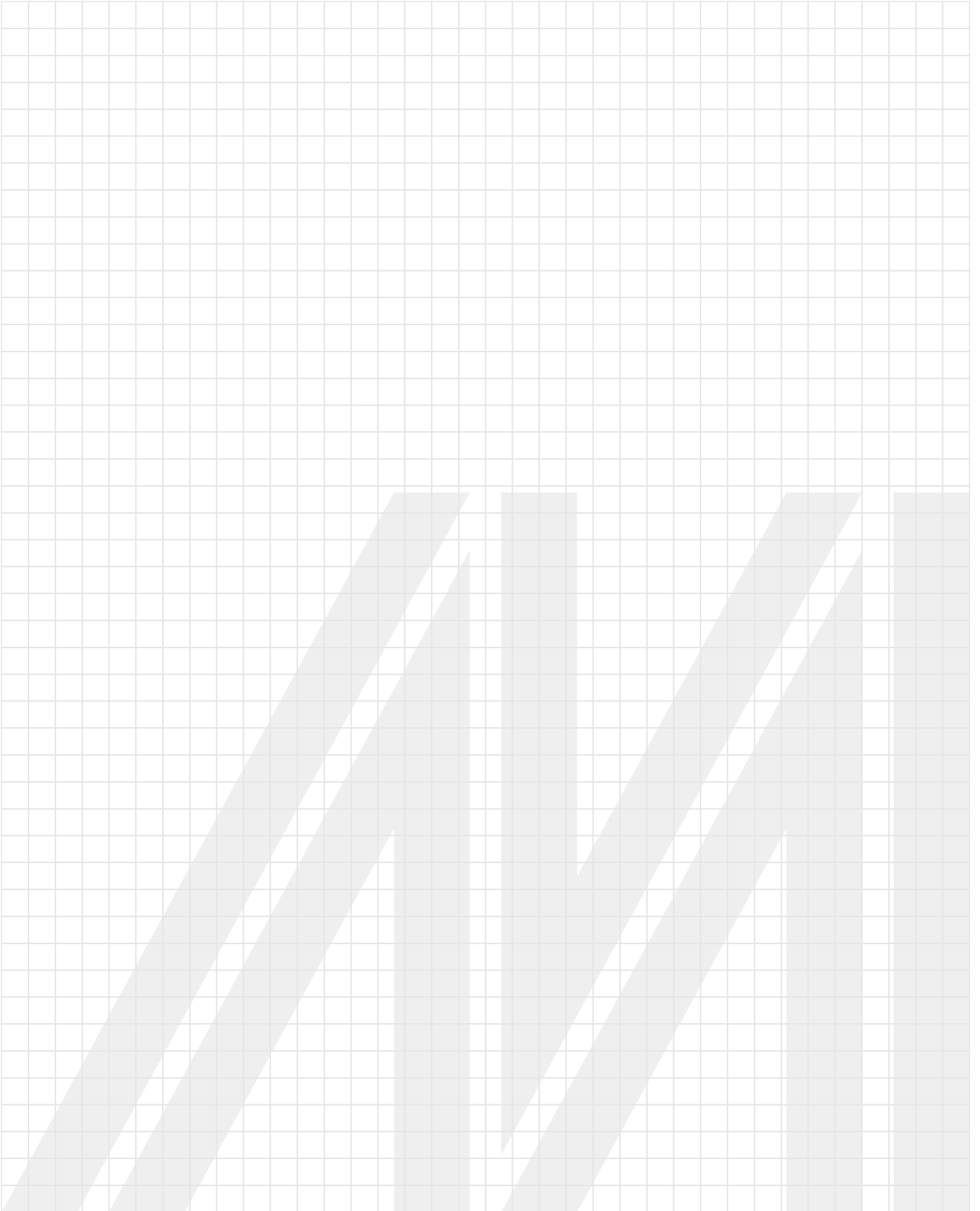

Solenoid Valve

Process Valve

Pilot & Mechanical Valve

Air Treatment Unit

Pressure Switch

Compressed Air Dryer

Auxiliary Equipment

PISCO®

PLC Control System

MACP200 series

AIR UNIT (F.R.L.UNIT)



Technical data



Filter element



T-bracket



User manual



Caution for safety
(Read before installing)



Symbol

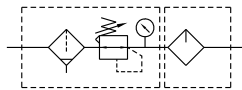

Specification

Model	MACP200	
Components	MAFR200, MAL200	
Bore No.	6A	8A
Port size	1/8	1/4
Medium	Air	
Operating perssure range (*)	0.05~1 MPa	
Proof pressure	1.5 MPa	
Regulated pressure range	0.05~0.85 MPa	
Ambient temperature	- 5~+60°C (No freezing)	
Filter element	Standard: 40μm, Option: 5μm	
Lubricating oil capacity	20c.c, 35c.c (MACP200L)	
Min. flow for oil drip	35 ℓ/min	50 ℓ/min
Recommended lubricating oil	Turbine oil ISO-VG32	
Attachment	Pressure gauge (PG-40), L-type bracket	
Weight	432 g, 380 g (MACP200L)	

* Standard unit contains semi-auto-drain function when operating pressure below 0.05 MPa.

Order example

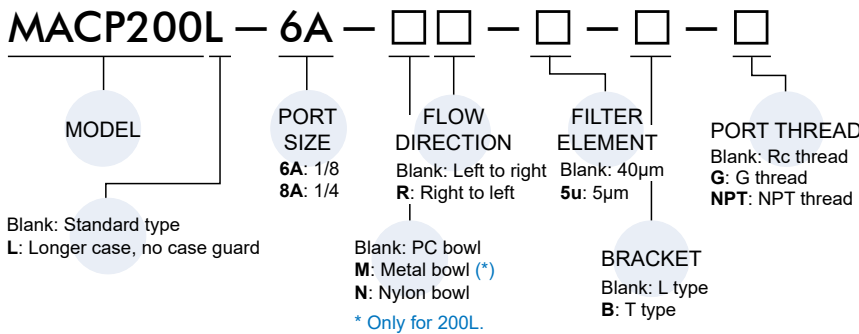

Flow feature

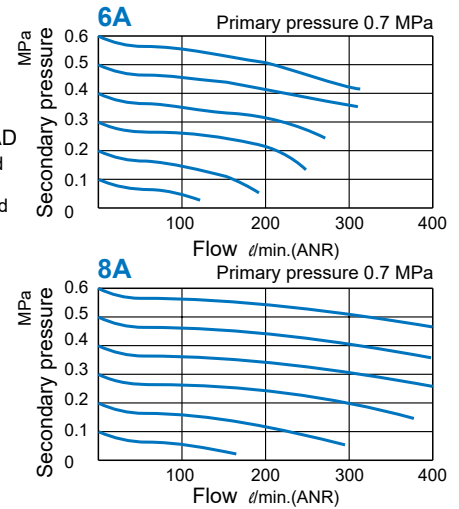

MACP200 Dimensions

AIR UNIT (F.R.L.UNIT)



MACP200-B

T type bracket

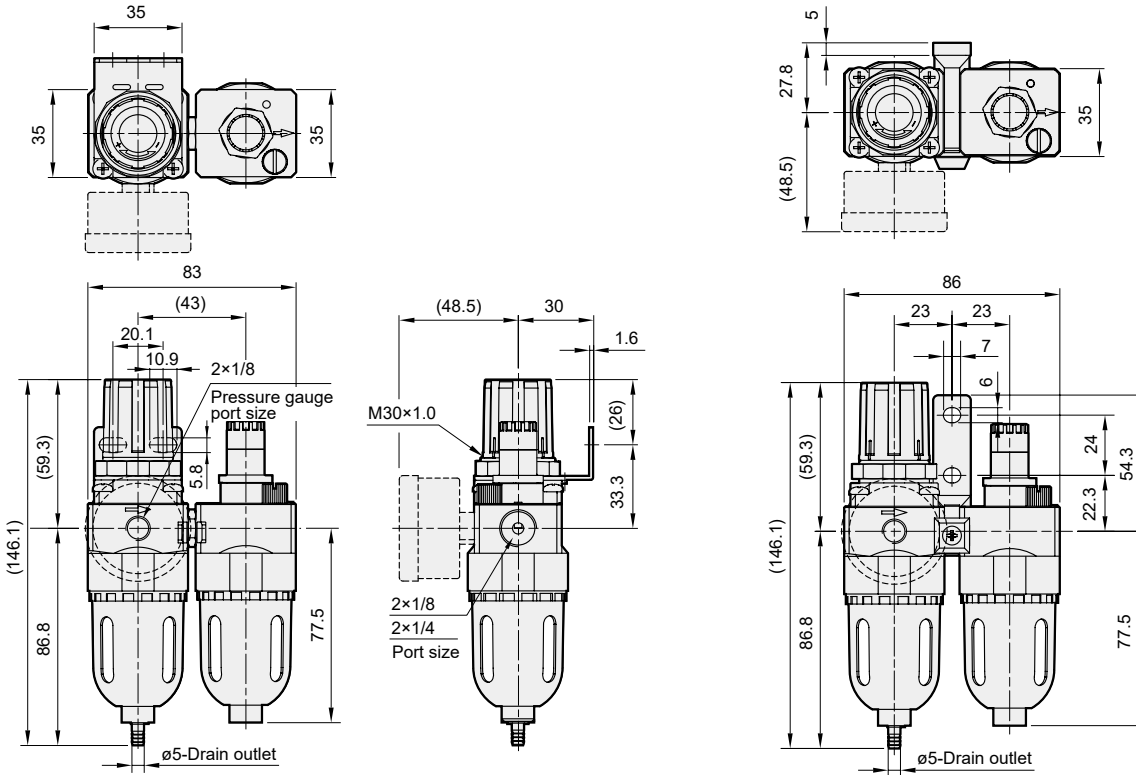

MACP200L-M-B

Metal bowl + T type bracket

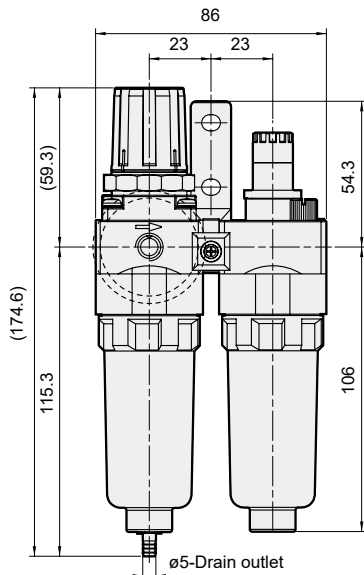

MACP200L-B

T type bracket

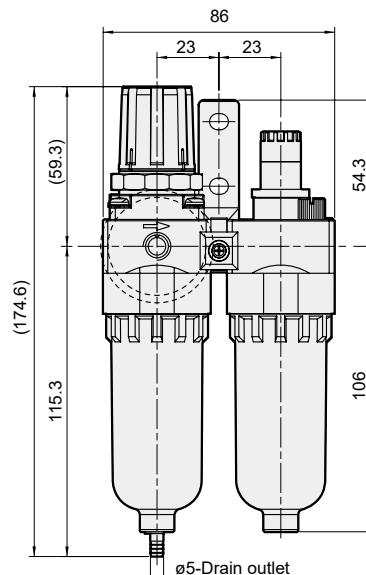

MACP302 series

AIR UNIT (F.R.L.UNIT)



Technical data



Filter element



User manual



Caution for safety
(Read before installing)



Option: **MP41**



Option: **MLF300**

Symbol

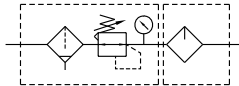

Specification

Model	MACP302		
Components	MAFR302, MAL302		
Bore No.	8A	10A	15A
Port size	1/4	3/8	1/2
Medium	Air		
Operating pressure range (*)	0.05~1 MPa		
Proof pressure	1.5 MPa		
Regulated pressure range	0.05~0.85 MPa		
Ambient temperature	- 5~+60°C (No freezing)		
Filter element	Standard: 5μm, Option: 40μm		
Lubricating oil capacity	65c.c		
Min. flow for oil drip	50 ℓ/min	60 ℓ/min	
Recommended lubricating oil	Turbine oil ISO-VG32		
Attachment	Pressure gauge(PG-20),T-type bracket		
Weight	845 g		

* Standard unit contains semi-auto-drain function when operating pressure below 0.05 MPa.

* Choose auto-drain FMRF300, the pressure range is 0.15~1 MPa.

Order example

MACP302 – 8A – NC□□□ – E1 – □ – T8 – HR – □

MODEL

PORT SIZE

8A: 1/4
10A: 3/8
15A: 1/2

PRESSURE SWITCH

Blank: without
E1: MP41P-022
E2: MP41P-022-QD**
E5: MP41P-042
E6: MP41P-042-QD**

** MOQ required. Please contact us.

FILTER ELEMENT

Blank: 5μm
40u: 40μm

BY-PASS PORT SIZE

	Blank	without
T type bracket	T8: 1/4 T10: 3/8 T15: 1/2	
Check valve (*2)	K8: 1/4 K10: 3/8	

PORT THREAD

Blank: Rc thread
G: G thread
NPT: NPT thread

SHUTOFF VALVE

Blank: without
HR: MVHR-302-3H
1: MVHR-302S-3H-AC110
1L: MVHR-302S-3H-AC110-L
1E: MVHR-302S-3H-AC110-E
2: MVHR-302S-3H-AC220
2L: MVHR-302S-3H-AC220-L
2E: MVHR-302S-3H-AC220-E
4: MVHR-302S-3H-DC24
4L: MVHR-302S-3H-DC24-L
4E: MVHR-302S-3H-DC24-E

* 302: Manual type, 302S: Solenoid type

* MVHR series

Bowl	Pressure gauge (*1)	Drain valve (for MAFR302)	Float switch (for MAL302)	Flow direction
Blank: PC bowl M: Metal bowl N: Nylon bowl	Blank: Pressure gauge (PG-20) C: External pressure gauge (PG-40) + Gauge adapter set (A-MAR302) A: Gauge adapter set (A-MAR302)	Blank: Semi-auto D: Auto (FMRF300)	Blank: without F: with (MLF300)	Blank: Left to right R: Right to left

1.PG-40 (C), A-MAR302 (A) and MP41 (E) can not be selected at the same time.

*2. Be sure to use above check valves when redirecting the air flow on the inlet side of the lubricator.

Flow feature

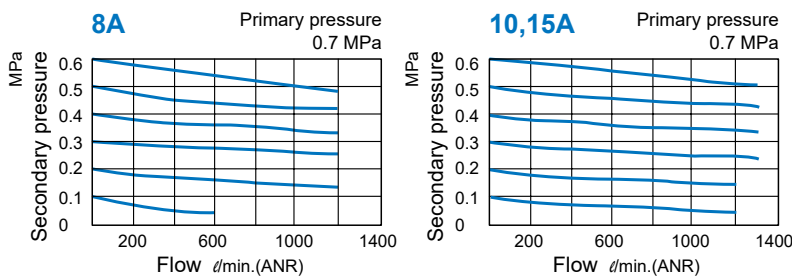

Caution

Metal bowl

Before assembling or disassembling, push the lock plate down to the end, and confirm that is detached from the body then rotate the bowl, otherwise the lock plate will be deformed or the body will be scratched.

- Sliding plate down
- Rotating the bowl

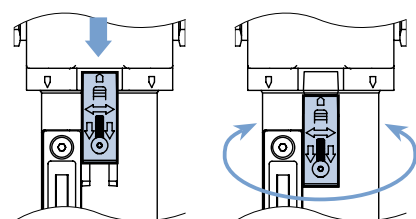

MACP302 Dimensions

AIR UNIT (F.R.L.UNIT)



Accessories

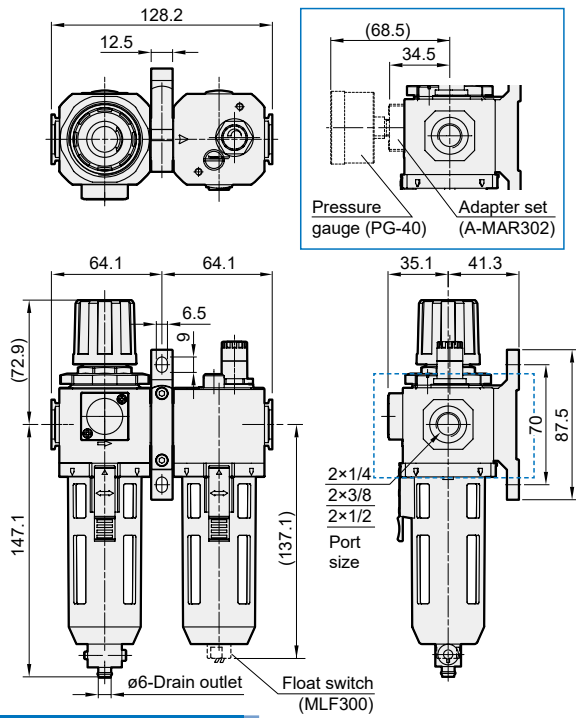

MACP302-T*

T type bracket

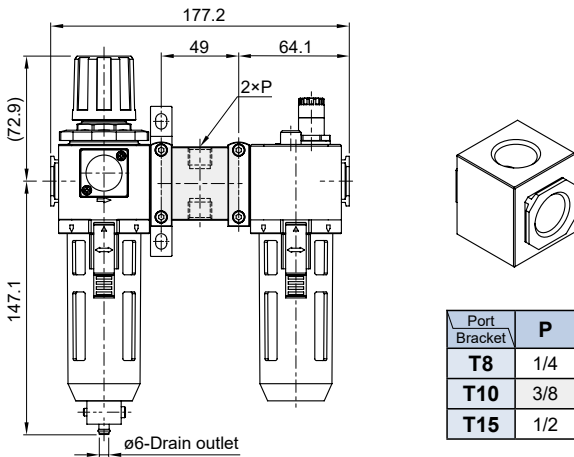

MACP302-K*

Check valve

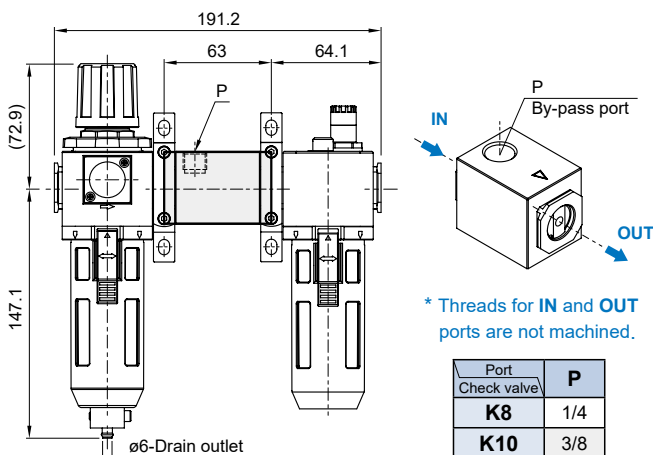

MACP302-D

Auto drain valve

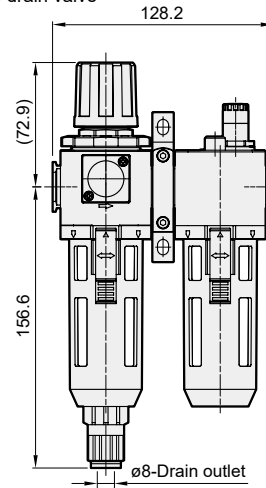

MACP302-M

Metal bowl

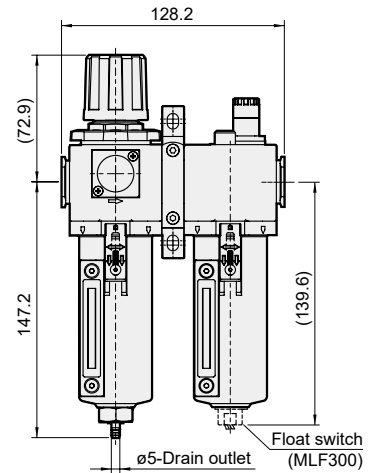

MACP302-MD

Metal bowl + Auto drain valve

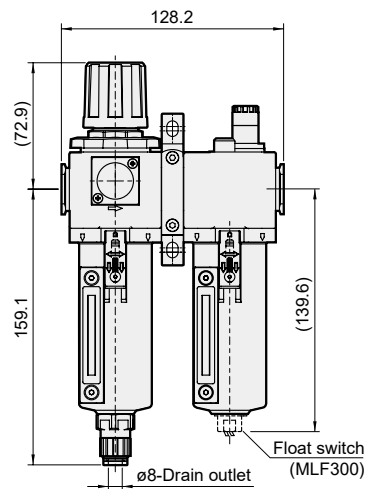

MACP302-HR With shutoff valve

AIR UNIT (F.R.L.UNIT)



MACP302-HR

With shutoff valve (MVHR-302)

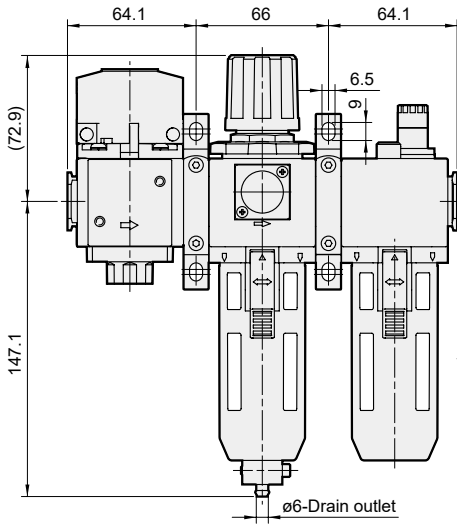
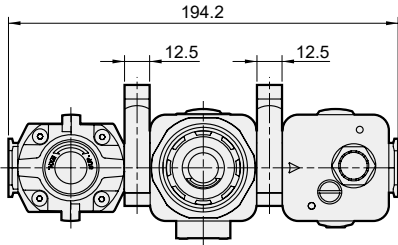

Accessories

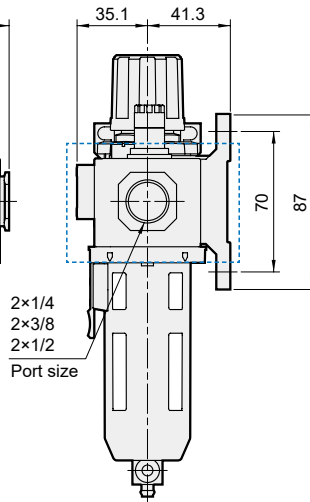
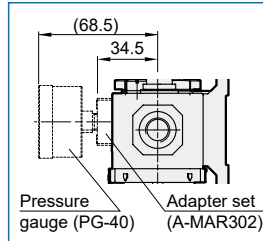

MACP302-1*1/2*/4*

With shutoff valve (MVHR-302S)

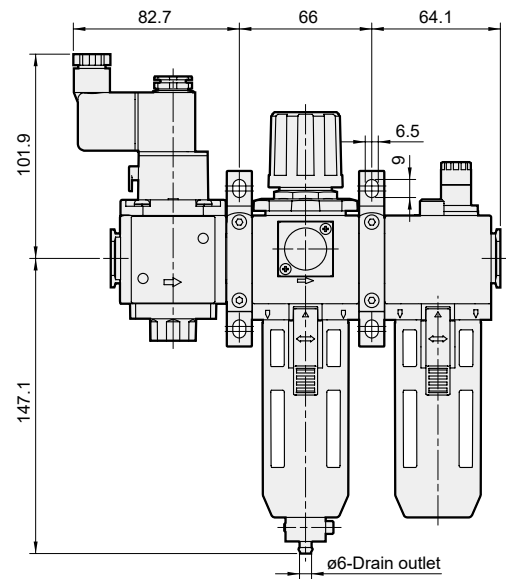
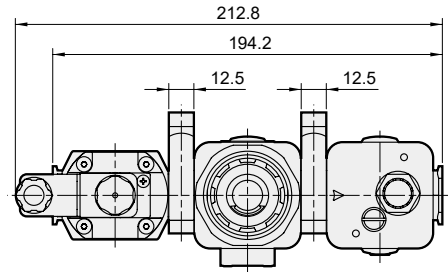

MACP400 series

AIR UNIT (F.R.L.UNIT)



Technical data



Filter element



User manual



Caution for safety
(Read before installing)



Symbol

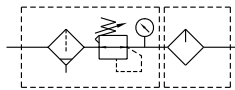

Specification

Model	MACP400		
Components	MAFR400, MAL400		
Bore No.	8A	10A	15A
Port size	1/4	3/8	1/2
Medium	Air		
Operating pressure range (*)	0.05~1 MPa		
Proof pressure	1.5 MPa		
Regulated pressure range	0.05~0.85 MPa		
Ambient temperature	- 5~+60°C (No freezing)		
Filter element	Standard: 40μm, Option: 5μm		
Lubricating oil capacity	200c.c		
Min. flow for oil drip	100 ℓ/min	200 ℓ/min	400 ℓ/min
Recommended lubricating oil	Turbine oil ISO-VG32		
Attachment	Pressure gauge (PG-50), bracket		
Weight	2300 g		

* Standard unit contains semi-auto-drain function when operating pressure below 0.05 MPa.

* Choose auto-drain FMRF300, the pressure range is 0.15~1 MPa.

Order example

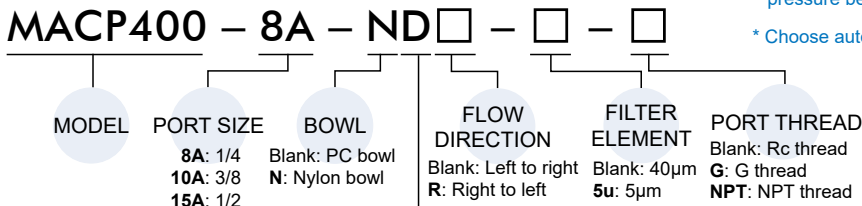

DRAIN VALVE
Blank: Semi-auto
D: Auto (FMRF300)

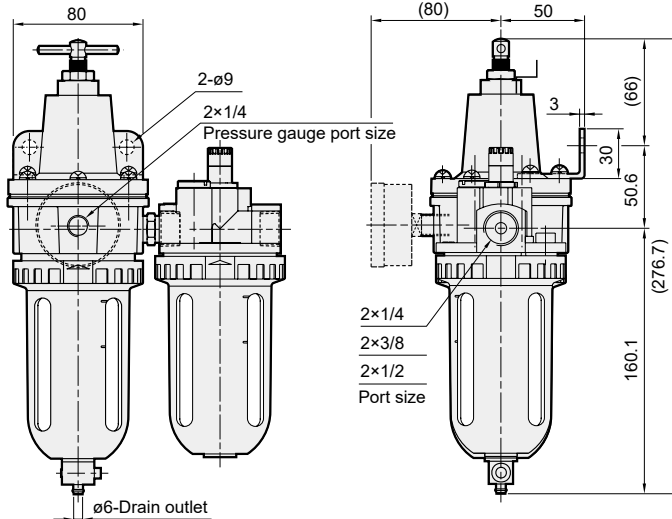
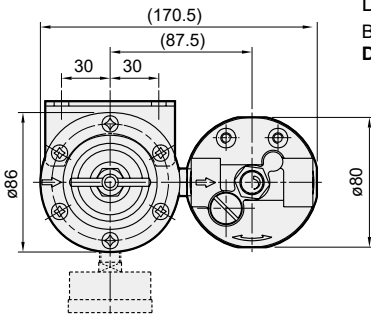

Flow feature

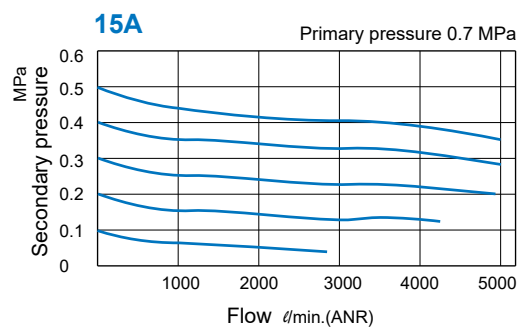
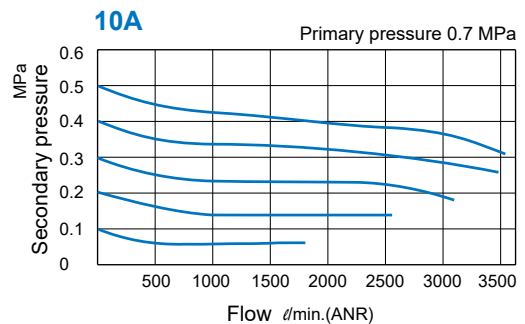

MACP401 series

AIR UNIT (F.R.L.UNIT)



Technical data



Filter element



User manual



Caution for safety
(Read before installing)



Option: **MP41**



Option: **MLF400**

Symbol

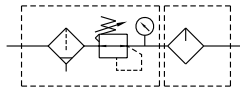

Specification

Model	MACP401		
Components	MAFR401, MAL401		
Bore No.	8A	10A	15A
Port size	1/4	3/8	1/2
Medium	Air		
Operating pressure range (*)	0.05~1.5 MPa		
Proof pressure	2 MPa		
Regulated pressure range	Standard type: 0.1~0.85 MPa High pressure type: 0.1~1.5 MPa		
Ambient temperature	- 5~+60°C (No freezing)		
Filter element	Standard: 40µm, Option: 5µm		
Lubricating oil capacity	200c.c		
Min. flow for oil drip	30 l/min	65 l/min	80 l/min
Recommended lubricating oil	Turbine oil ISO-VG32		
Attachment	Pressure gauge (PG-20), L-type bracket		
Weight	1518 g		

* Standard unit contains semi-auto-drain function when operating pressure below 0.05 MPa.

* Choose auto-drain FMRF300, the pressure range is 0.15~1 MPa.

Order example

MACP401-8A-□-HA□□P□-E1-□-T8-HR-□

MODEL

PORT SIZE

8A: 1/4
10A: 3/8
15A: 1/2

EXTERIOR COLOR

Blank: Black & silver
W: Gray & white

PRESSURE SWITCH

Blank: without
E1: MP41P-022
E2: MP41P-022-QD**
E5: MP41P-042
E6: MP41P-042-QD**

** MOQ required. Please contact us.

FILTER ELEMENT

Blank: 40µm
5u: 5µm

BY-PASS PORT SIZE

	Blank	without
T type bracket		T8: 1/4 T10: 3/8 T15: 1/2
Check valve		K8: 1/4 K10: 3/8

PORT THREAD

Blank: Rc thread
G: G thread
NPT: NPT thread

Type	Pressure gauge	Drain valve (for MAFR401)	Float switch (for MAL401)	Pressure switch	Flow direction
Blank: Standard type	Blank: Pressure gauge (PG-20) C: External pressure gauge (PG-40) + Gauge adapter set (A-MAR401) A: Gauge adapter set (A-MAR401)	Blank: Semi-auto D: Auto (FMRF300)	Blank: without F: with (MLF400)	Blank: without P: Pressure switch (MPS series)	Blank: Left to right R: Right to left
H: High pressure type	C: External pressure gauge (PG-40) + Gauge adapter set (A-MAR401) A: Gauge adapter set (A-MAR401)	Blank: Semi-auto		-	

SHUTOFF VALVE

Blank: without
HR: MVHR-400-3H
1: MVHR-400S-3H-AC110
1L: MVHR-400S-3H-AC110-L
1E: MVHR-400S-3H-AC110-E
2: MVHR-400S-3H-AC220
2L: MVHR-400S-3H-AC220-L
2E: MVHR-400S-3H-AC220-E
4: MVHR-400S-3H-DC24
4L: MVHR-400S-3H-DC24-L
4E: MVHR-400S-3H-DC24-E

* Specification (W) gauge adapter set (A-MAR302).

* PG-40 (C), A-MAR302 (A) and MP41 (E*) can not be selected at the same time.

* Be sure to use above check valves when redirecting the air flow on the inlet side of the lubricator.

* 400: Manual type, 400S: Solenoid type

* MVHR series

Flow feature

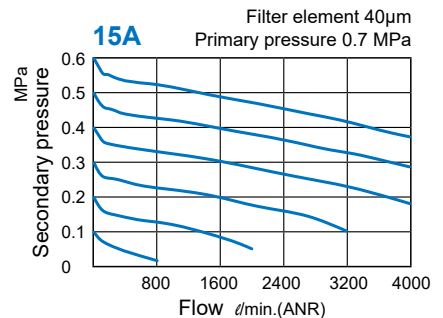
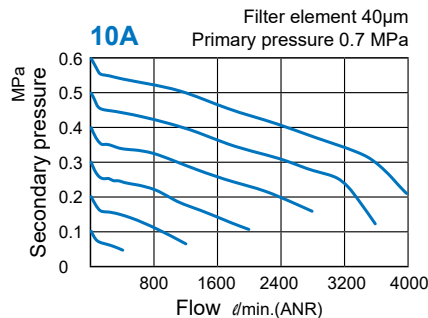
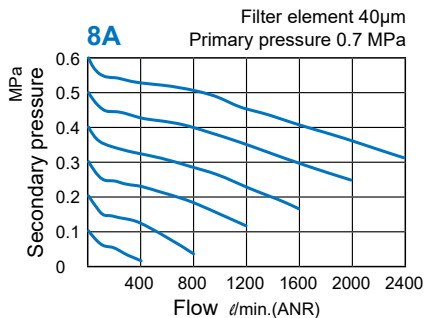

MACP401 Dimensions

AIR UNIT (F.R.L.UNIT)



Accessories

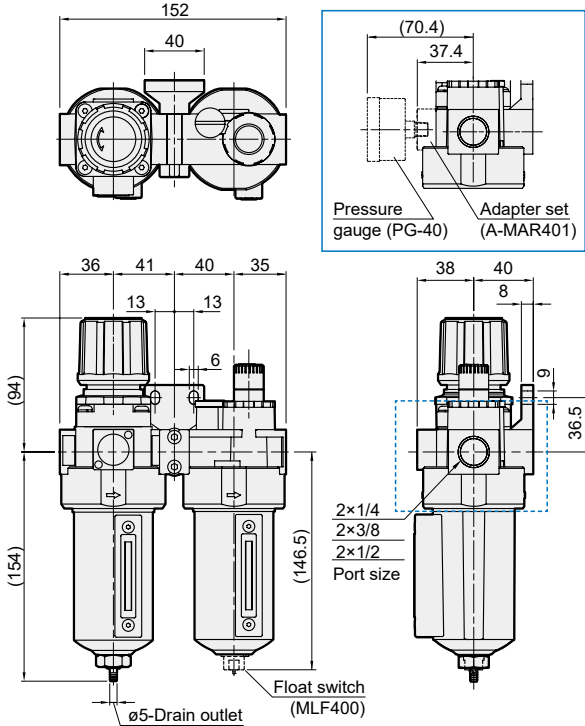

MACP401-D

Auto drain valve

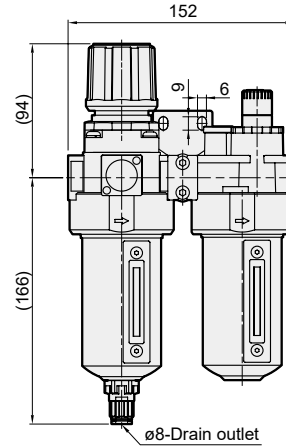

MACP401-T*

T type bracket

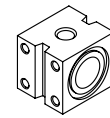
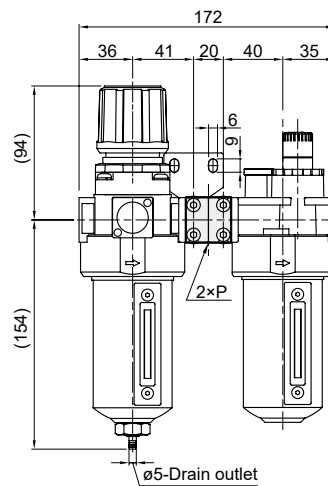

Port Bracket	P
T8	1/4
T10	3/8
T15	1/2

MACP401-K*

Check valve

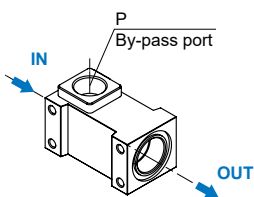
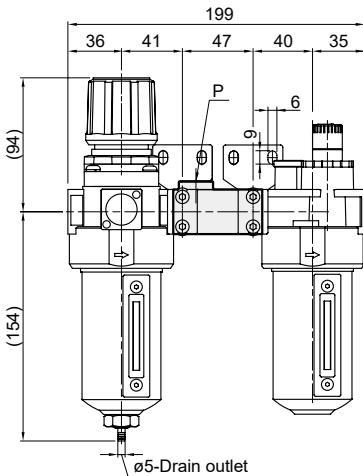

Port Check valve	P
K8	1/4
K10	3/8

* Threads for IN and OUT ports are not machined.

MACP401-P

MPS Series pneumatic pressure switch

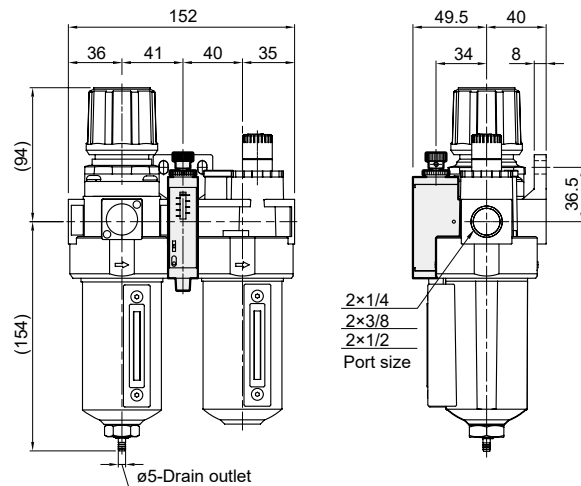

MACP401-HR With shutoff valve

AIR UNIT (F.R.L.UNIT)



MACP401-HR

With shutoff valve (MVHR-400)

MACP401-1*1/2*/4*

With shutoff valve (MVHR-400S)

Accessories

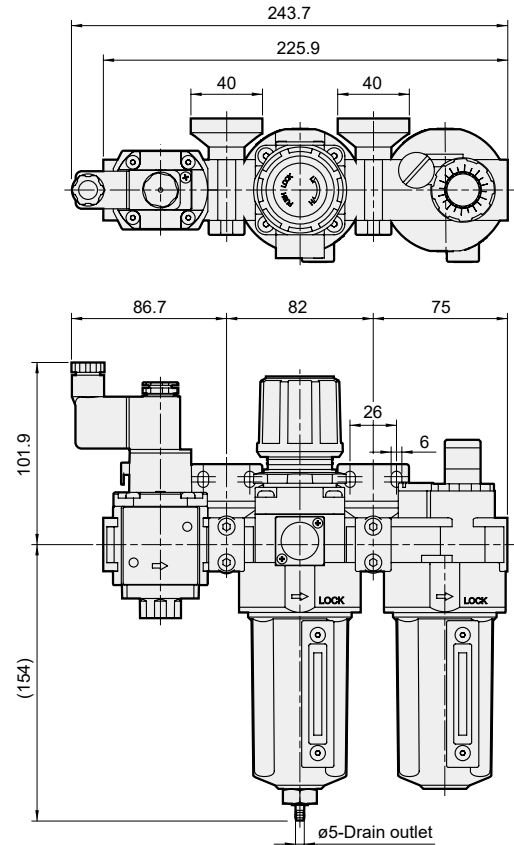
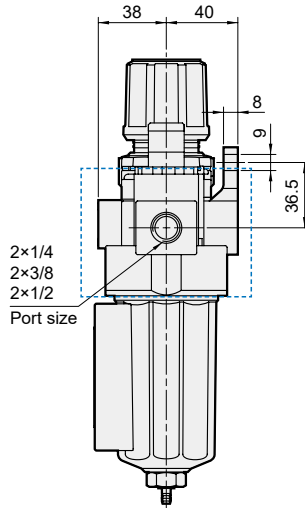
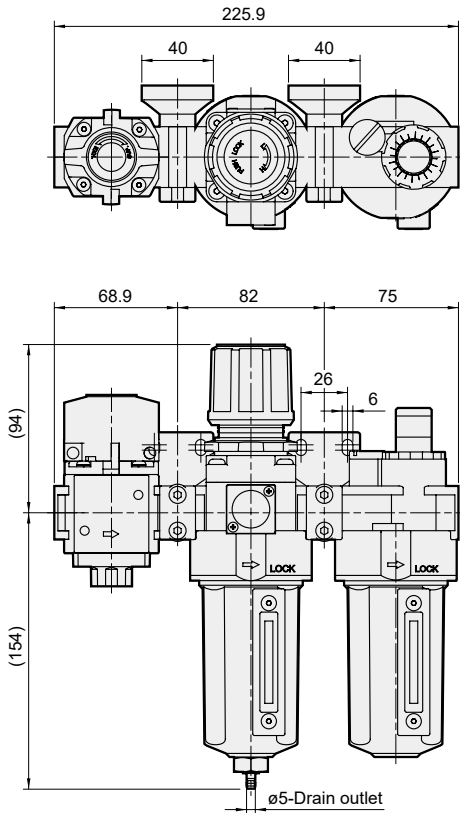
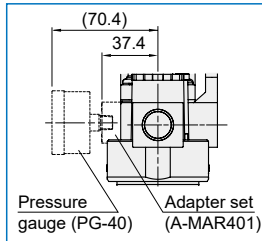

MACP403 series

AIR UNIT (F.R.L.UNIT)



Technical data



Filter element



User manual



Caution for safety
(Read before installing)



Option: **MP41**



Option: **MLF400**

Symbol

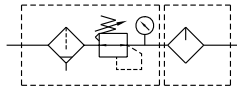

Specification

Model	MACP403		
Components	MAFR403, MAL403		
Bore No.	8A	10A	15A
Port size	1/4	3/8	1/2
Medium	Air		
Operating pressure range (*)	0.05~1 MPa		
Proof pressure	1.5 MPa		
Regulated pressure range	0.1~0.85 MPa		
Ambient temperature	- 5~+60°C (No freezing)		
Filter element	Standard: 40µm, Option: 5µm		
Lubricating oil capacity	200c.c		
Min. flow for oil drip	30 ℓ/min	65 ℓ/min	80 ℓ/min
Recommended lubricating oil	Turbine oil ISO-VG32		
Attachment	Pressure gauge (PG-20), L-type bracket		
Weight	1100 g		

* Standard unit contains semi-auto-drain function when operating pressure below 0.05 MPa.

* Choose auto-drain FMRF300, the pressure range is 0.15~1 MPa.

Order example

MACP403 – 8A – NC□□P□ – E1 – □ – T8 – HR – □

MODEL

PORT SIZE

8A: 1/4
10A: 3/8
15A: 1/2

PRESSURE SWITCH

Blank: without
E1: MP41P-022
E2: MP41P-022-QD**
E5: MP41P-042
E6: MP41P-042-QD**

** MOQ required. Please contact us.

FILTER ELEMENT

Blank: 40µm
5µ: 5µm

BY-PASS PORT SIZE

Blank	without
T type bracket	T8: 1/4 T10: 3/8 T15: 1/2
Check valve	K8: 1/4 K10: 3/8

PORT THREAD

Blank: Rc thread
G: G thread
NPT: NPT thread

SHUTOFF VALVE

Blank: without
HR: MVHR-400-3H
1: MVHR-400S-3H-AC110
1L: MVHR-400S-3H-AC110-L
1E: MVHR-400S-3H-AC110-E
2: MVHR-400S-3H-AC220
2L: MVHR-400S-3H-AC220-L
2E: MVHR-400S-3H-AC220-E
4: MVHR-400S-3H-DC24
4L: MVHR-400S-3H-DC24-L
4E: MVHR-400S-3H-DC24-E

Bowl	Pressure gauge	Drain valve	Float switch (for MAL403)	Pressure switch	Flow direction
Blank: PC bowl N: Nylon bowl	Blank: Pressure gauge (PG-20) C: External pressure gauge (PG-40) + Gauge adapter set (A-MAR302) A: Gauge adapter set (A-MAR302)	Blank: Semi-auto D: Auto (FMRF300)	Blank: without F: with (MLF400)	Blank: without P: Pressure switch (MPS series)	Blank: Left to right R: Right to left

* PG-40 (C), A-MAR302 (A) and MP41 (E*) can not be selected at the same time.

* Be sure to use above check valves when redirecting the air flow on the inlet side of the lubricator.

* 400: Manual type,
400S: Solenoid type.
* MVHR series

Flow feature

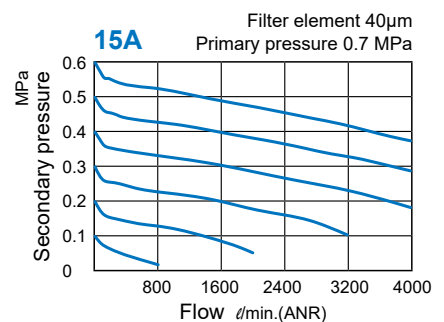
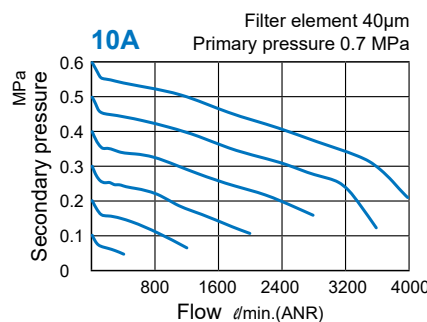
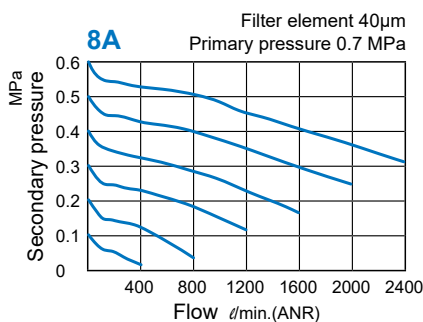

MACP403 Dimensions

AIR UNIT (F.R.L.UNIT)



Accessories

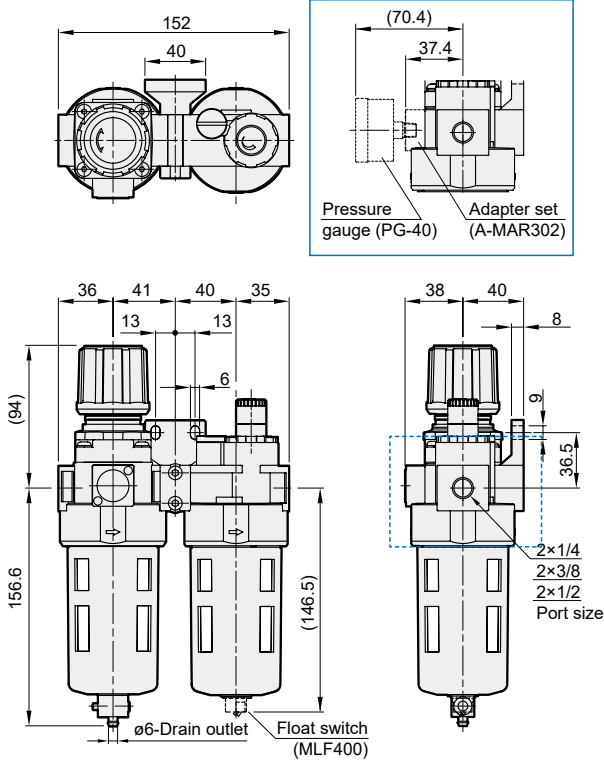

MACP403-D

Auto drain valve

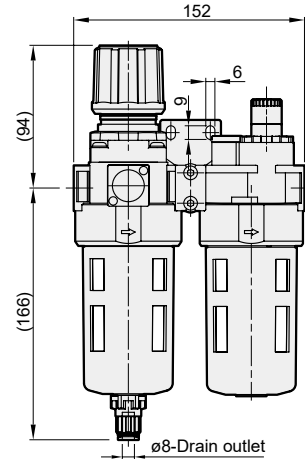

MACP403-T*

T type bracket

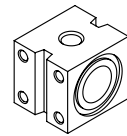
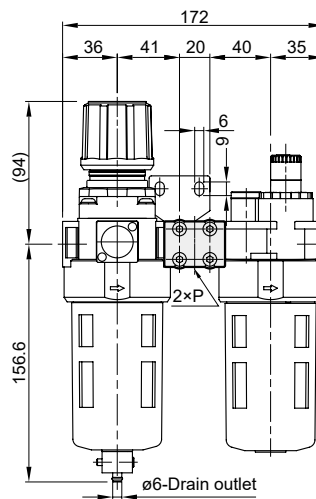

Port Bracket	P
T8	1/4
T10	3/8
T15	1/2

MACP403-K*

Check valve

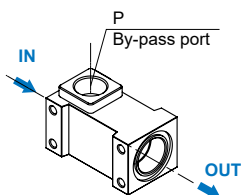
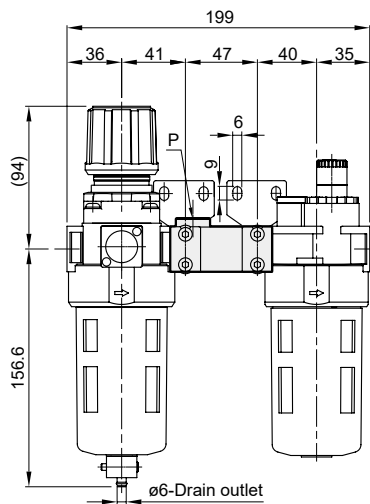

Port Check valve	P
K8	1/4
K10	3/8

MACP403-P

MPS Series pneumatic pressure switch

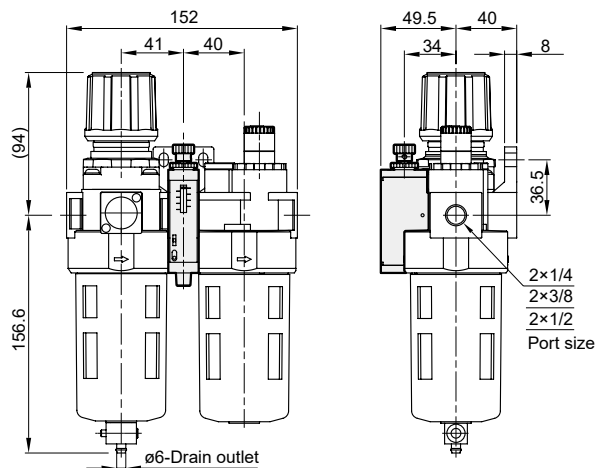

* Threads for IN and OUT ports are not machined.

MACP403-HR With shutoff valve

AIR UNIT (F.R.L.UNIT)



MACP403-HR

With shutoff valve (MVHR-400)

MACP403-1*¹/₂*¹/₄*

With shutoff valve (MVHR-400S)

Accessories

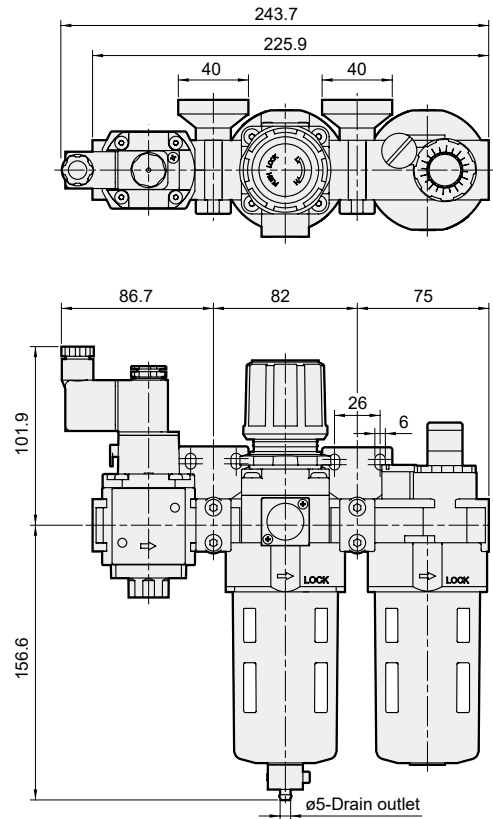
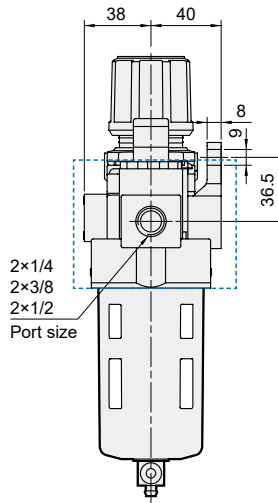
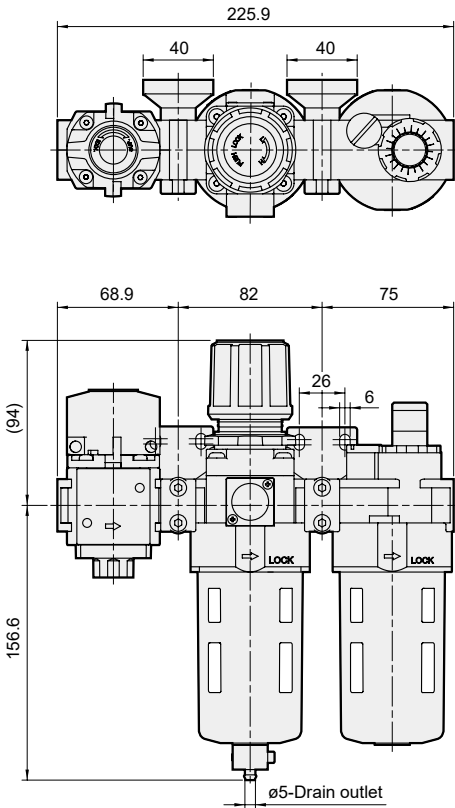
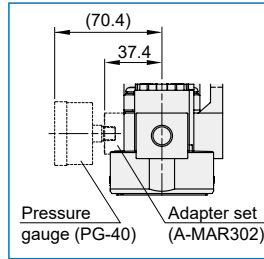

Solenoid Valve

Process Valve

Pilot & Mechanical Valve

Air Treatment Unit

Pressure Switch

Compressed Air Dryer

Auxiliary Equipment

PISCO®

PLC Control System

MACP501 series

AIR UNIT (F.R.L.UNIT)



Technical data



Filter element



User manual



Caution for safety
(Read before installing)



Option: **MP41**

Symbol

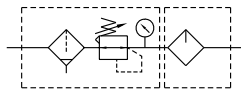

Specification

Model	MACP501	
Components	MAFR501, MAL501	
Bore No.	20A	25A
Port size	3/4	1
Medium	Air	
Operating pressure range (*)	PC, Nylon	0.05~1 MPa
	Metal bowl	0.05~1.5 MPa
Proof pressure	PC, Nylon	1.5 MPa
	Metal bowl	2 MPa
Regulated pressure range	0.05~0.85 MPa	
Ambient temperature	- 5~+60°C (No freezing)	
Filter element	40µm	
Lubricating oil capacity	200c.c	
Min. flow for oil drip	25 ℓ/min	33 ℓ/min
Recommended lubricating oil	Turbine oil ISO-VG32	
Attachment	Pressure gauge (PG-20), bracket	
Weight	Nylon bowl, PC bowl: 3480 g	
	Metal bowl: 3720 g	

* Standard unit contains semi-auto-drain function when operating pressure below 0.05 MPa.

** Choose auto-drain FMRF300, the pressure range is 0.15~1 MPa.

Order example

MACP501 – 20A – MC□□ – E1 – T8 – □

MODEL

PORT SIZE

20A: 3/4
25A: 1

PRESSURE SWITCH

Blank: without
E1: MP41P-022
E2: MP41P-022-QD**
E5: MP41P-042
E6: MP41P-042-QD**

** MOQ required. Please contact us.

MODULE MOUNTING BRACKET

Blank: without
T8: 1/4
T10: 3/8
T15: 1/2

PORT THREAD

Blank: Rc thread
G: G thread
NPT: NPT thread

Bowl	Pressure gauge	Drain valve	Flow direction
Blank: PC bowl M: Metal bowl N: Nylon bowl	Blank: Pressure gauge (PG-20) C: External pressure gauge (PG-40) + Gauge adapter set (A-MAR302) A: Gauge adapter set (A-MAR302)	Blank: Semi-auto D: Auto (FMRF300)	Blank: Left to right R: Right to left

* PG-40 (C), A-MAR302 (A) and MP41 (E*) can not be selected at the same time.

Flow feature

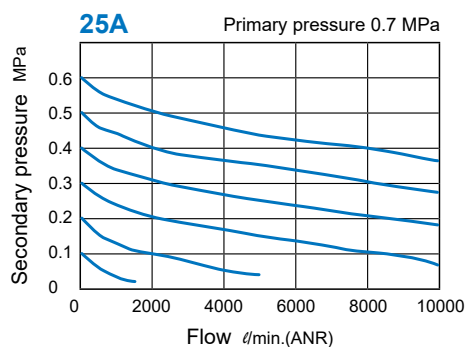
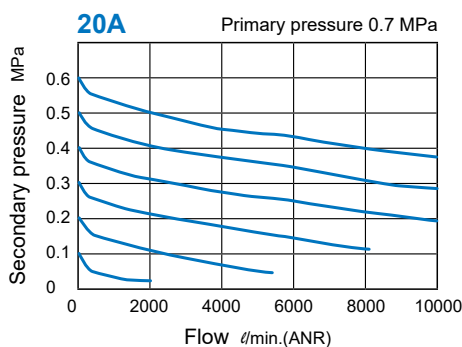

MACP501 Dimensions

AIR UNIT (F.R.L.UNIT)



Accessories

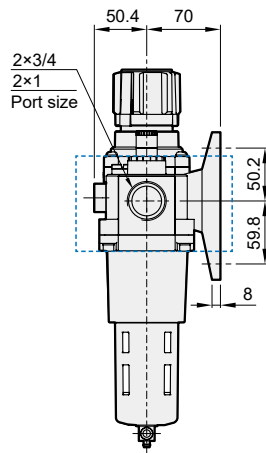
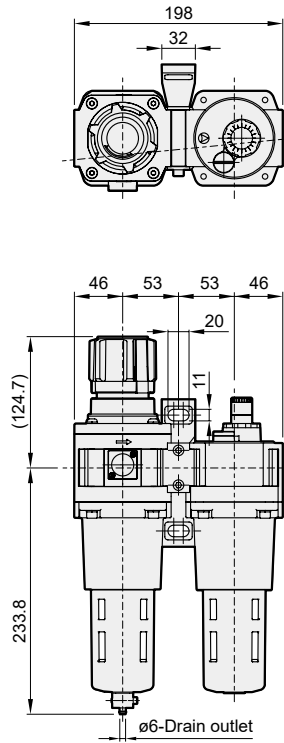
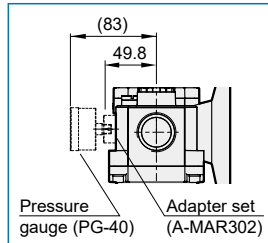

MACP501-M

Metal bowl

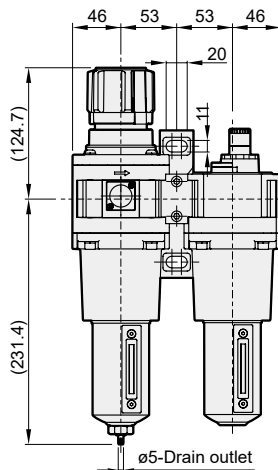
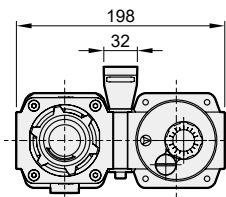

MACP501-D

Auto drain valve

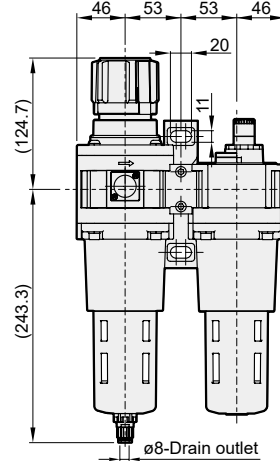

MACP501-T*

T type bracket

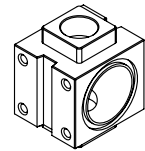
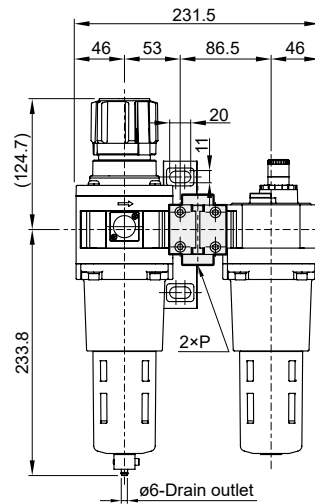

Port Bracket	P
T8	1/4
T10	3/8
T15	1/2

MACP501-MD

Metal bowl + auto drain valve

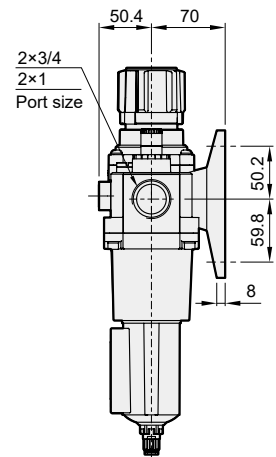
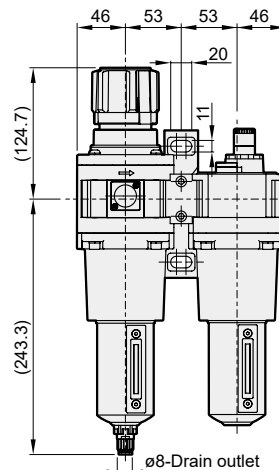

MACT200 series

AIR UNIT (F.R.L.UNIT)



Technical data



Filter element



T-bracket



User manual



Caution for safety
(Read before installing)



MACT200L

Symbol

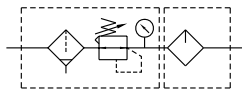

Specification

Model	MACT200	
Components	MAF200, MAR201, MAL200	
Bore No.	6A	8A
Port size	1/8	1/4
Medium	Air	
Operating pressure range (*)	0.05~1 MPa	
Proof pressure	1.5 MPa	
Regulated pressure range	0.05~0.85 MPa	
Ambient temperature	- 5~+60°C (No freezing)	
Filter element	Standard: 40μm, Option: 5μm	
Lubricating oil capacity	20c.c, 35c.c (MACT200L)	
Min. flow for oil drip	35 ℓ/min	50 ℓ/min
Recommended lubricating oil	Turbine oil ISO-VG32	
Attachment	Pressure gauge(PG-40), L-type bracket	
Weight	505 g, 465 g (MACT200L)	

* Standard unit contains auto-drain function when operating pressure below 0.05 MPa.

Order example

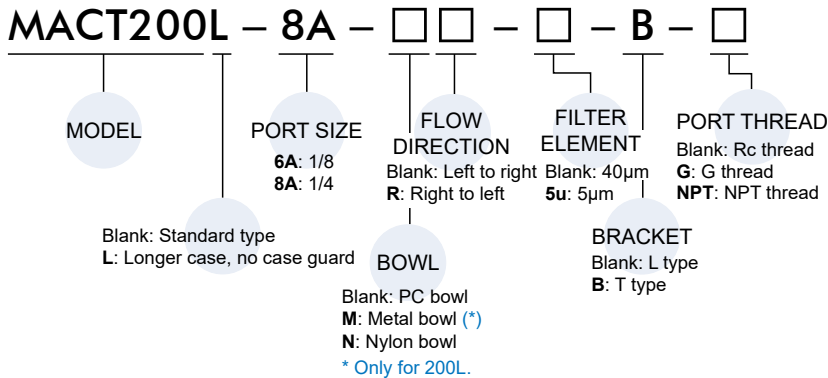

Flow feature

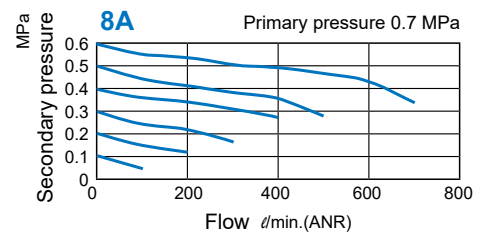
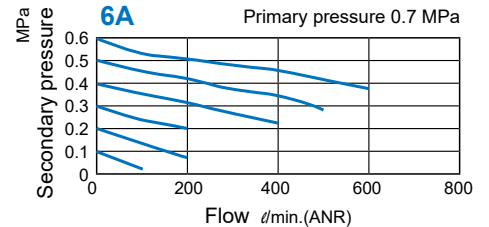

MACT200 Dimensions

AIR UNIT (F.R.L.UNIT)



MACT200-B

T type bracket

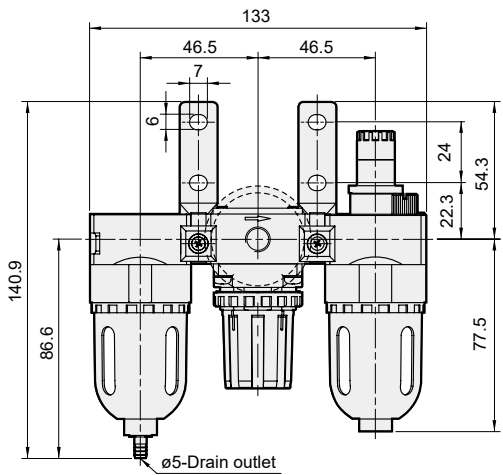
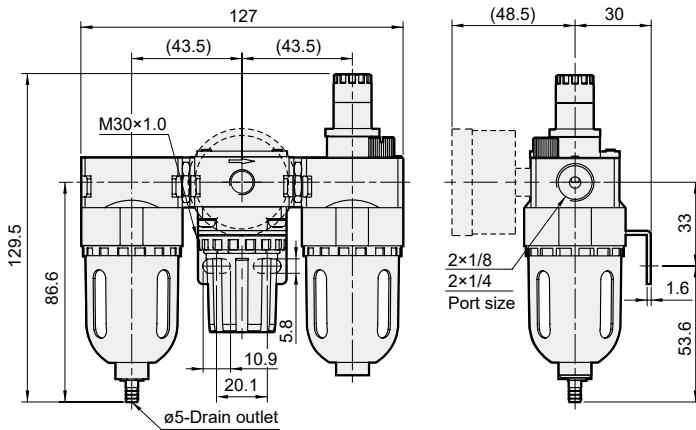
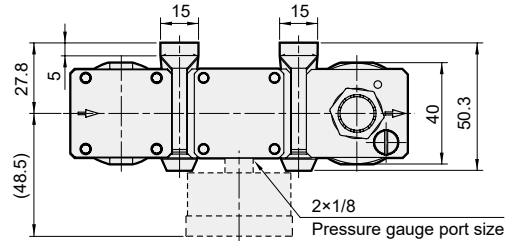
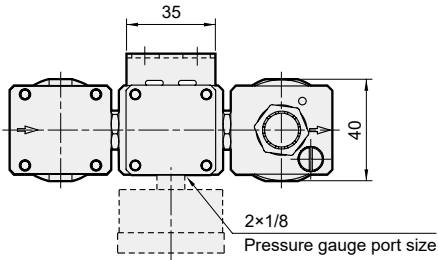

MACT200L-M-B

Metal bowl + T type bracket

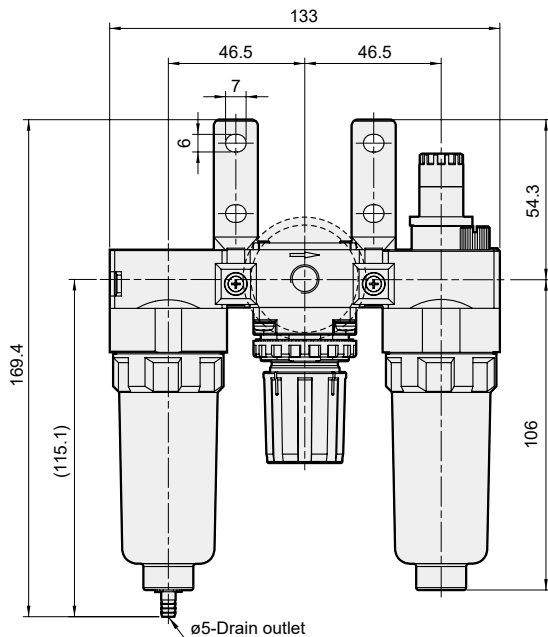

MACT200L-B

T type bracket

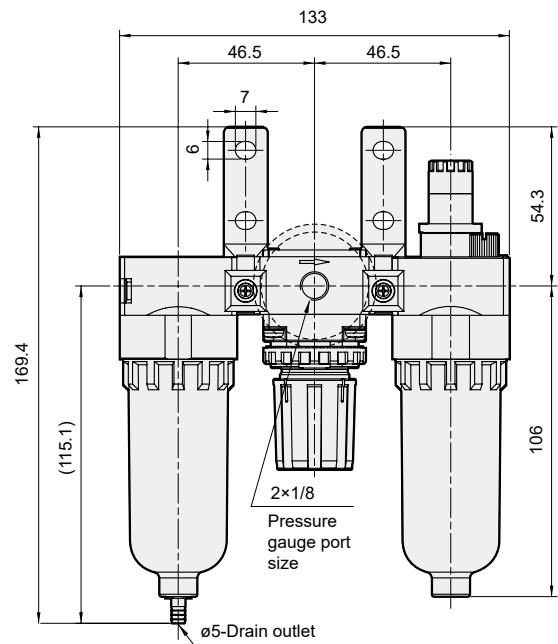

MACT302 series

AIR UNIT (F.R.L.UNIT)



Specification

Model	MACT302		
Components	MAF302, MAR302, MAL302		
Bore No.	8A	10A	15A
Port size	1/4	3/8	1/2
Medium	Air		
Operating pressure range (*)	0.05~1 MPa		
Proof pressure	1.5 MPa		
Effective orifice	32mm ²	34mm ²	
Regulated pressure range	0.05~0.85 MPa		
Ambient temperature	- 5~+60°C (No freezing)		
Filter element	Standard: 5µm, Option: 40µm		
Lubricating oil capacity	65c.c		
Min. flow for oil drip	50 l/min	60 l/min	
Recommended lubricating oil	Turbine oil ISO-VG32		
Attachment	Pressure gauge (PG-20), T-type bracket		
Weight	1115 g		

* Standard unit contains semi-auto-drain function when operating pressure below 0.05 MPa.

* Choose auto-drain FMRF300, the pressure range is 0.15~1 MPa.



Technical data



Filter element



User manual



Caution for safety
(Read before installing)



Option: **MP41**



Option: **MLF300**

Symbol

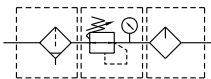

Order example

MACT302 – 8A – NC□□□ – E1 – □ – T8 – □

MODEL

PORT SIZE

8A: 1/4
10A: 3/8
15A: 1/2

PRESSURE SWITCH

Blank: without
E1: MP41P-022
E2: MP41P-022-QD**
E5: MP41P-042
E6: MP41P-042-QD**
** MOQ required.
Please contact us.

FILTER ELEMENT

Blank: 5µm
40u: 40µm

BY-PASS PORT SIZE

Blank	without
T type bracket	T8: 1/4 T10: 3/8 T15: 1/2
Check valve (*2)	K8: 1/4 K10: 3/8

PORT THREAD

Blank: Rc thread
G: G thread
NPT: NPT thread

Bowl	Pressure gauge (*1)	Drain valve (for MAF302)	Float switch (for MAL302)	Flow direction
Blank: PC bowl M: Metal bowl N: Nylon bowl	Blank: Pressure gauge (PG-20) C: External pressure gauge (PG-40) + Gauge adapter set (A-MAR302) A: Gauge adapter set (A-MAR302)	Blank: Semi-auto D: Auto (FMRF300)	Blank: without F: with (MLF300)	Blank: Left to right R: Right to left

1. PG-40 (C), A-MAR302 (A) and MP41 (E) can not be selected at the same time.

*2. Be sure to use above check valves when redirecting the air flow on the inlet side of the lubricator.

Caution

Flow feature

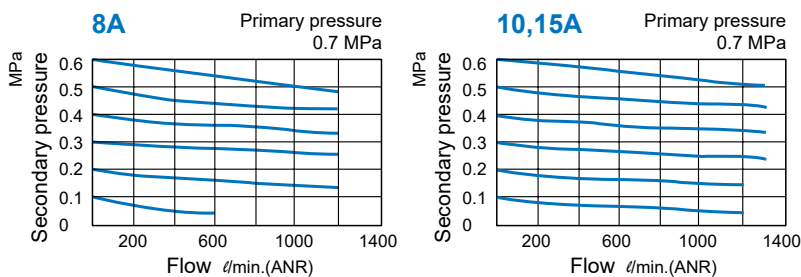

Metal bowl

Before assembling or disassembling, push the lock plate down to the end, and confirm that is detached from the body then rotate the bowl, otherwise the lock plate will be deformed or the body will be scratched.

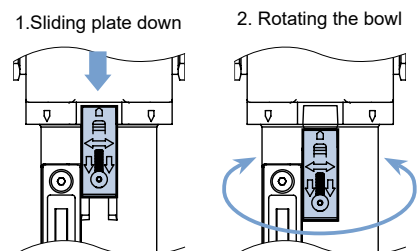

MACT302 Dimensions

AIR UNIT (F.R.L.UNIT)



Accessories

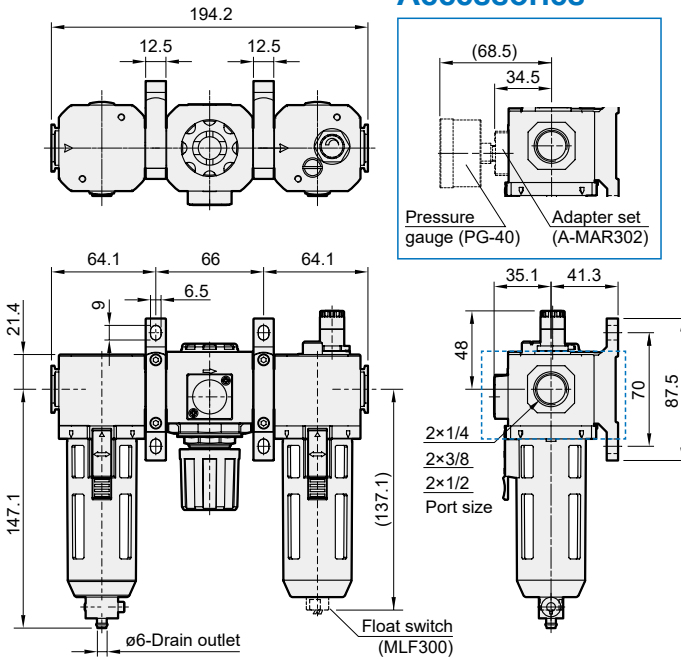

MACT302-D

Auto drain valve

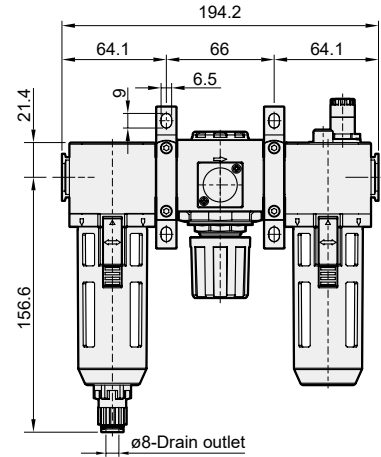

MACT302-M

Metal bowl

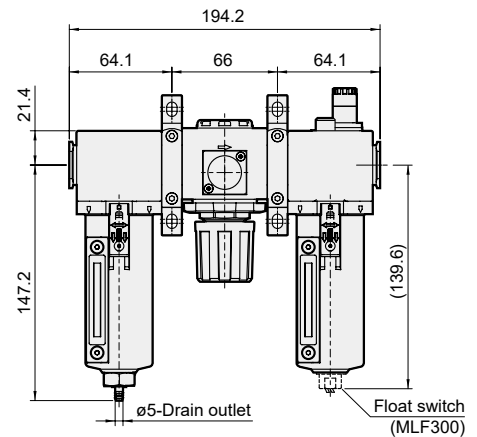

MACT302-T*

T type bracket

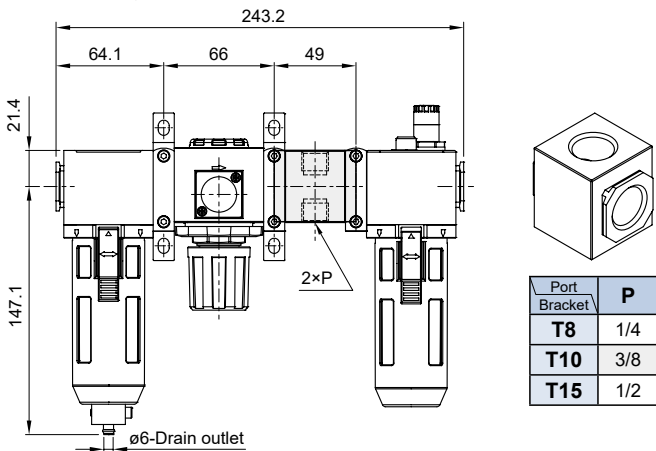

MACT302-MD

Metal bowl + Auto drain valve

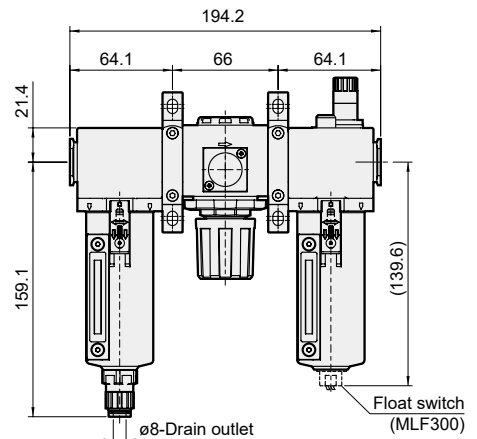

MACT302-K*

Check valve

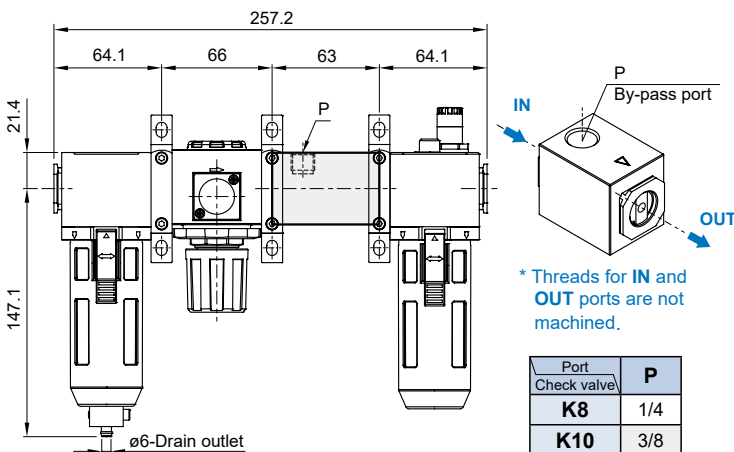

MACT400 series

AIR UNIT (F.R.L.UNIT)



Technical data



Filter element



User manual



Caution for safety
(Read before installing)



Specification

Model	MACT400		
Components	MAF400, MAR400, MAL400		
Bore No.	8A	10A	15A
Port size	1/4	3/8	1/2
Medium	Air		
Operating pressure range (*)	0.05~1 MPa		
Proof pressure	1.5 MPa		
Effective orifice	24mm ²	35mm ²	40mm ²
Regulated pressure range	0.05~0.85 MPa		
Ambient temperature	- 5~+60°C (No freezing)		
Filter element	Standard: 40μm, Option: 5μm		
Lubricating oil capacity	200c.c		
Min. flow for oil drip	100 ℓ/min	200 ℓ/min	400 ℓ/min
Recommended lubricating oil	Turbine oil ISO-VG32		
Attachment	Pressure gauge (PG-50), bracket		
Weight	2000 g		

Symbol

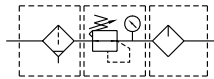

Order example

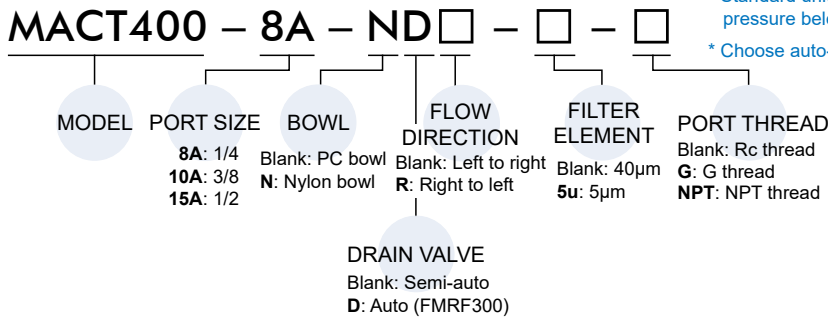

* Standard unit contains semi-auto-drain function when operating pressure below 0.05 MPa.

* Choose auto-drain FMRF300, the pressure range is 0.15~1 MPa.

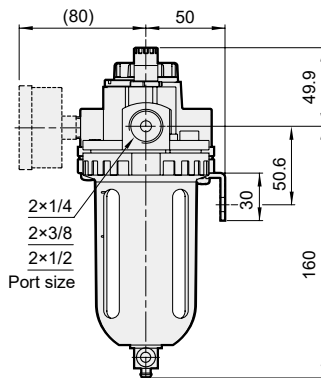
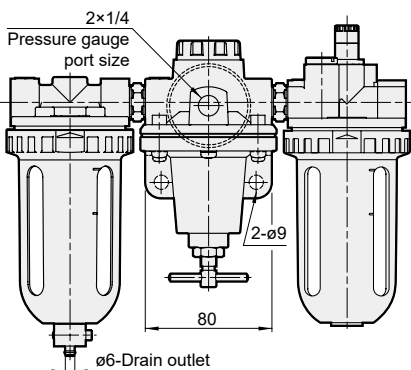
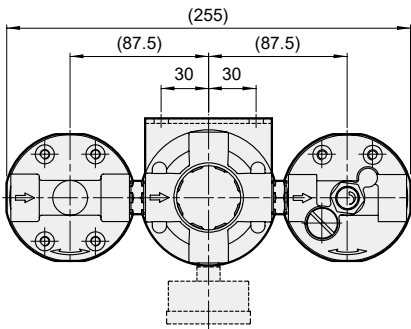

Flow feature

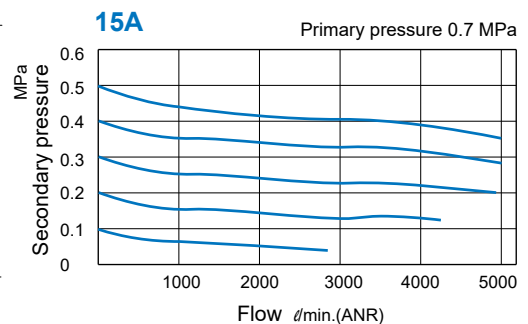
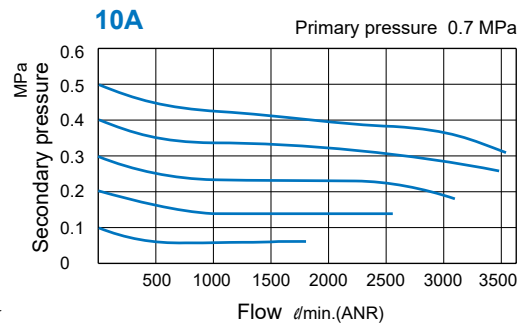

MACT401 series

AIR UNIT (F.R.L.UNIT)



Technical data



Filter element



User manual



Caution for safety
(Read before installing)



Option: **MP41**



Option: **MLF400**

Symbol

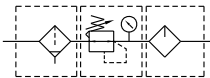

Specification

Model	MACT401		
Components	MAF401, MAR401, MAL401		
Bore No.	8A	10A	15A
Port size	1/4	3/8	1/2
Medium	Air		
Operating pressure range (*)	0.05~1.5 MPa		
Proof pressure	2 MPa		
Regulated pressure range	Standard: 0.1~0.85 MPa High pressure: 0.1~1.5 MPa		
Ambient temperature	- 5~+60°C (No freezing)		
Filter element	Standard: 40µm, Option: 5µm		
Lubricating oil capacity	200c.c		
Min. flow for oil drip	30 l/min	65 l/min	80 l/min
Recommended lubricating oil	Turbine oil ISO-VG32		
Attachment	Pressure gauge (PG-20), L-type bracket		
Weight	1812 g		

* Standard unit contains semi-auto-drain function when operating pressure below 0.05 MPa.

* Choose auto-drain FMRF300, the pressure range is 0.15~1 MPa.

Order example

MACT401 - 8A - [] - HA[][]P[] - E1 - [] - T8 - []

MODEL	PORT SIZE	EXTERIOR COLOR	PRESSURE SWITCH	FILTER ELEMENT	BY-PASS PORT SIZE	PORT THREAD
8A: 1/4 10A: 3/8 15A: 1/2	Blank: Black & silver W: Gray & white	Blank: without E1: MP41P-022 E2: MP41P-022-QD** E5: MP41P-042 E6: MP41P-042-QD** ** MOQ required. Please contact us.	Blank: 40µm 5u: 5µm	Blank T type bracket Check valve	without T8: 1/4 T10: 3/8 T15: 1/2 K8: 1/4 K10: 3/8	Blank: Rc thread G: G thread NPT: NPT thread

Type	Pressure gauge	Drain valve (for MAF401)	Float switch (for MAL401)	Pressure switch	Flow direction
Blank: Standard type	Blank: Pressure gauge (PG-20) C: External pressure gauge (PG-40) + Gauge adapter set (A-MAR401) A: Gauge adapter set (A-MAR401)	Blank: Semi-auto D: Auto (FMRF300)	Blank: without F: with (MLF400)	Blank: without P: Pressure switch (MPS series)	Blank: Left to right R: Right to left
H: High pressure type	C: External pressure gauge (PG-40) + Gauge adapter set (A-MAR401) A: Gauge adapter set (A-MAR401)	Blank: Semi-auto		-	

* PG-40 (C), A-MAR302 (A) and MP41 (E*) can not be selected at the same time.

* Specification (W) gauge adapter set (A-MAR302).

* Be sure to use above check valves when redirecting the air flow on the inlet side of the lubricator.

Flow feature

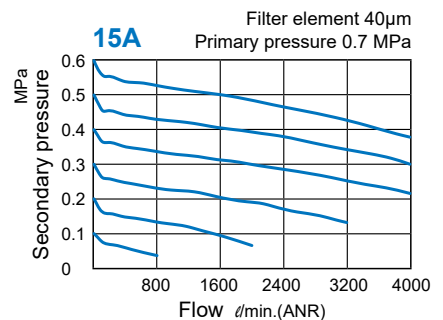
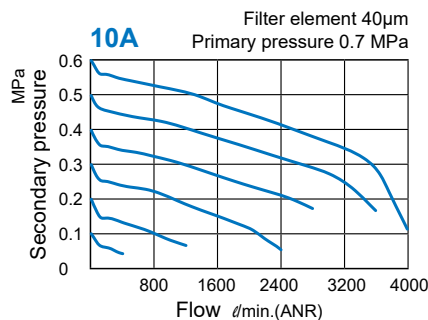
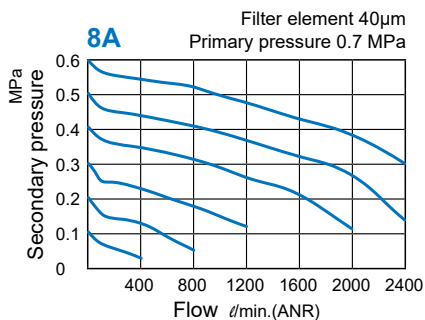

MACT401 Dimensions

AIR UNIT (F.R.L.UNIT)



Accessories

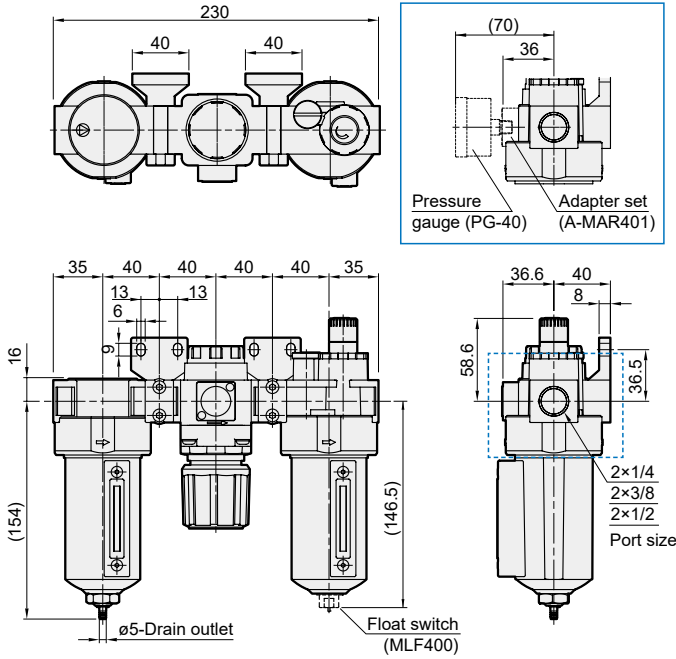

MACT401-D

Auto drain valve

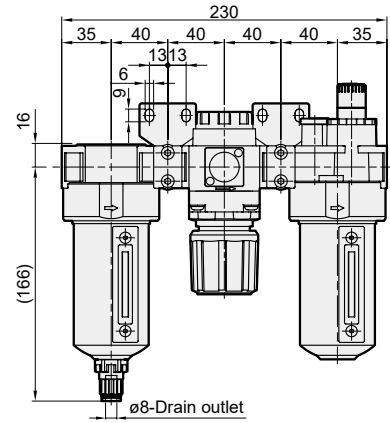

MACT401-T*

T type bracket

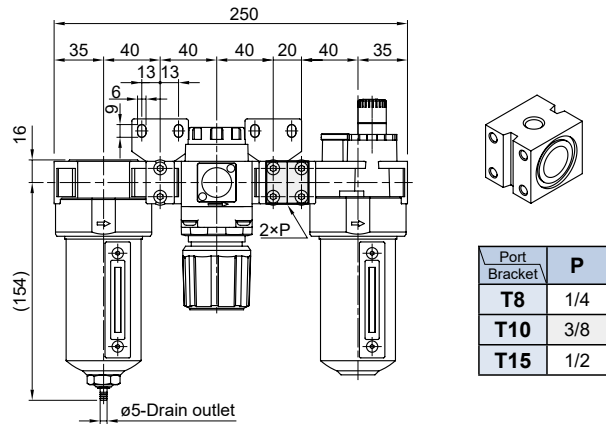

MACT401-K*

Check valve

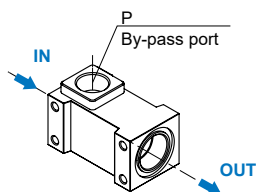
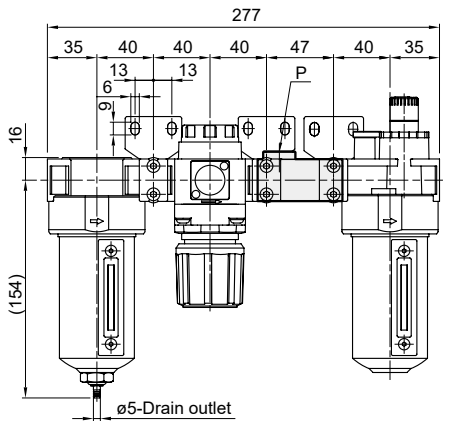

Port Check valve	P
K8	1/4
K10	3/8

* Threads for IN and OUT ports are not machined.

MACT401-P

MPS Series
pneumatic pressure switch

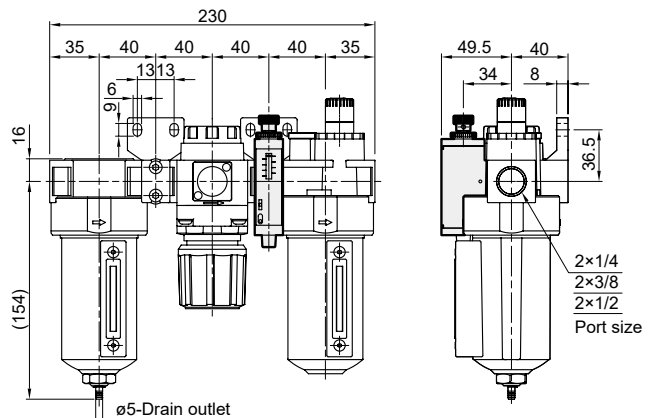

MACT403 series

AIR UNIT (F.R.L.UNIT)



Technical data



Filter element



User manual



Caution for safety
(Read before installing)



Option: **MP41**



Option: **MLF400**

Specification

Model	MACT403		
Components	MAF403, MAR403, MAL403		
Bore No.	8A	10A	15A
Port size	1/4	3/8	1/2
Medium	Air		
Operating pressure range (*)	0.05~1 MPa		
Proof pressure	1.5 MPa		
Regulated pressure range	0.1~0.85 MPa		
Ambient temperature	- 5~+60°C (No freezing)		
Filter element	Standard: 40μm, Option: 5μm		
Lubricating oil capacity	200c.c		
Min. flow for oil drip	30 l/min	65 l/min	80 l/min
Recommended lubricating oil	Turbine oil ISO-VG32		
Attachment	Pressure gauge (PG-20), L-type bracket		
Weight	1345 g		

* Standard unit contains semi-auto-drain function when operating pressure below 0.05 MPa.

* Choose auto-drain FMRF300, the pressure range is 0.15~1 MPa.

Symbol

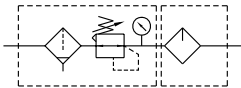

Order example

MACT403 – 8A – NC□□P□ – E1 – □ – T8 – □

MODEL

PORT SIZE

8A: 1/4
10A: 3/8
15A: 1/2

PRESSURE SWITCH

Blank: without
E1: MP41P-022
E2: MP41P-022-QD**
E5: MP41P-042
E6: MP41P-042-QD**
** MOQ required.
Please contact us.

FILTER ELEMENT

Blank: 40μm
5u: 5μm

BY-PASS PORT SIZE

Blank	without
T type bracket	T8: 1/4 T10: 3/8 T15: 1/2
Check valve	K8: 1/4 K10: 3/8

PORT THREAD

Blank: Rc thread
G: G thread
NPT: NPT thread

Bowl	Pressure gauge	Drain valve	Float switch (for MAL403)	Pressure switch	Flow direction
Blank: PC bowl N: Nylon bowl	Blank: Pressure gauge (PG-20) C: External pressure gauge (PG-40) + Gauge adapter set (A-MAR302) A: Gauge adapter set (A-MAR302)	Blank: Semi-auto D: Auto (FMRF300)	Blank: without F: with (MLF400)	Blank: without P: Pressure switch (MPS series)	Blank: Left to right R: Right to left

* PG-40 (C), A-MAR302 (A) and MP41 (E*) can not be selected at the same time.

* Be sure to use above check valves when redirecting the air flow on the inlet side of the lubricator.

Flow feature

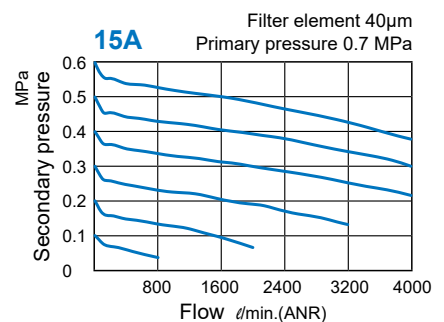
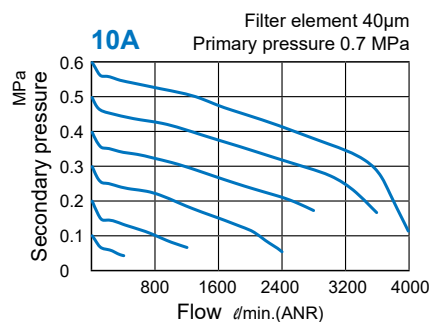
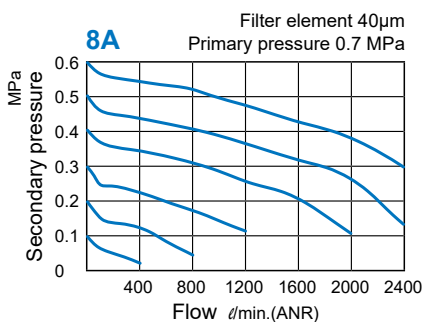

MACT403 Dimensions

AIR UNIT (F.R.L.UNIT)



Accessories

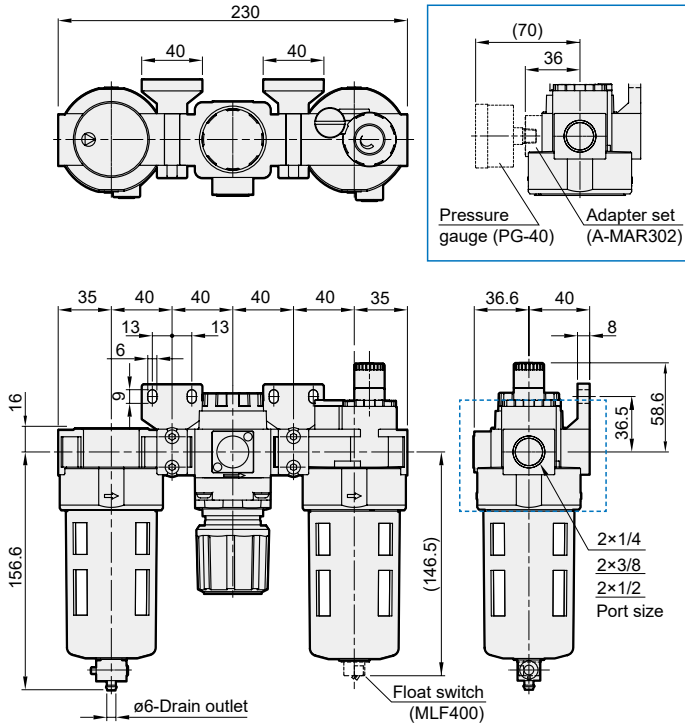

MACT403-D

Auto drain valve

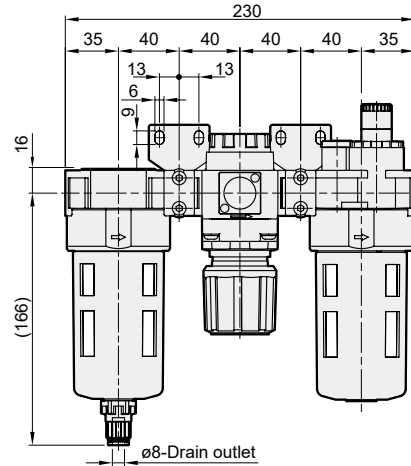

MACT403-T*

T type bracket

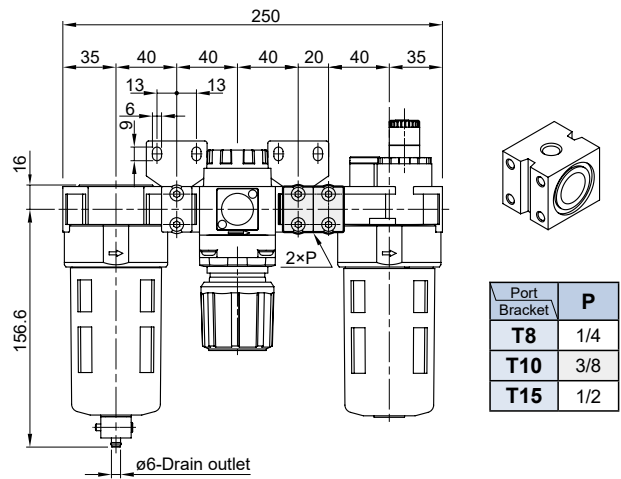

MACT403-K*

Check valve

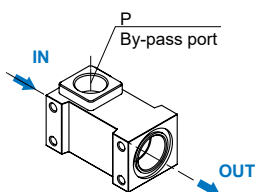
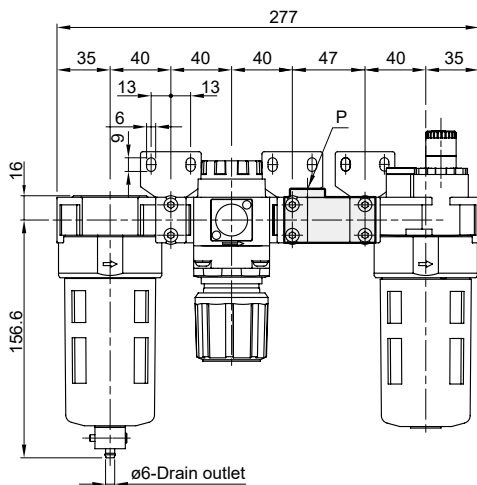

Port Check valve	P
K8	1/4
K10	3/8

* Threads for IN and OUT ports are not machined.

MACT403-P

MPS Series pneumatic pressure switch

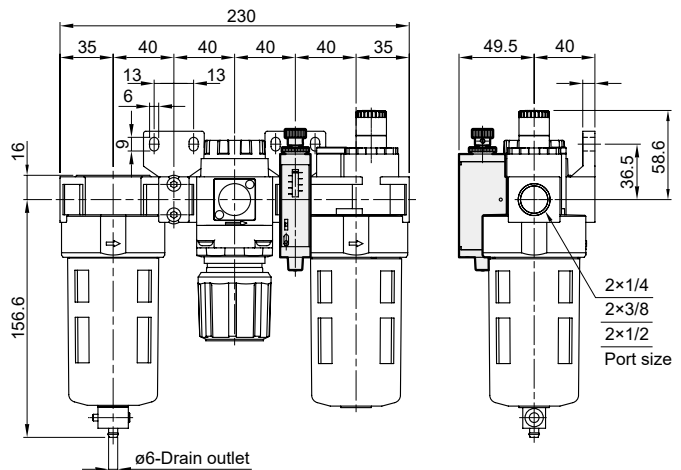

MACT501 series

AIR UNIT (F.R.L.UNIT)



Technical data



Filter element



User manual



Caution for safety
(Read before installing)



Option: MP41

Specification

Model		MACT501	
Components		MAF501, MAR501, MAL501	
Bore No.	20A	25A	
Port size	3/4	1	
Medium		Air	
Operating pressure range (*)	PC, Nylon	0.05~1 MPa	
	Metal bowl	0.05~1.5 MPa	
Proof pressure	PC, Nylon	1.5 MPa	
	Metal bowl	2 MPa	
Regulated pressure range		0.05~0.85 MPa	
Ambient temperature		- 5~+60°C (No freezing)	
Filter element		40µm	
Lubricating oil capacity		200c.c	
Min. flow for oil drip	25 ℓ/min	33 ℓ/min	
Recommended lubricating oil		Turbine oil ISO-VG32	
Attachment		Pressure gauge (PG-20), bracket	
Weight	Nylon bowl, PC bowl: 4200 g		
	Metal bowl: 4440 g		

* Standard unit contains semi-auto-drain function when operating pressure below 0.05 MPa.

* Choose auto-drain FMRF300, the pressure range is 0.15~1 MPa.

Symbol

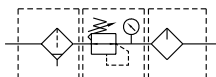

Order example

MACT501 – 20A – MC□□ – E1 – T8 – □

MODEL

PORT SIZE
20A: 3/4
25A: 1

PRESSURE SWITCH

Blank: without
E1: MP41P-022
E2: MP41P-022-QD**
E5: MP41P-042
E6: MP41P-042-QD**
** MOQ required.
Please contact us.

MODULE MOUNTING BRACKET

Blank: without
T8: 1/4
T10: 3/8
T15: 1/2

PORT THREAD

Blank: Rc thread
G: G thread
NPT: NPT thread

Bowl	Pressure gauge	Drain valve	Flow direction
Blank: PC bowl M: Metal bowl N: Nylon bowl	Blank: Pressure gauge (PG-20) C: External pressure gauge (PG-40) + Gauge adapter set (A-MAR302) A: Gauge adapter set (A-MAR302)	Blank: Semi-auto D: Auto (FMRF300)	Blank: Left to right R: Right to left

* PG-40 (C), A-MAR302 (A) and MP41 (E*) can not be selected at the same time.

Flow feature

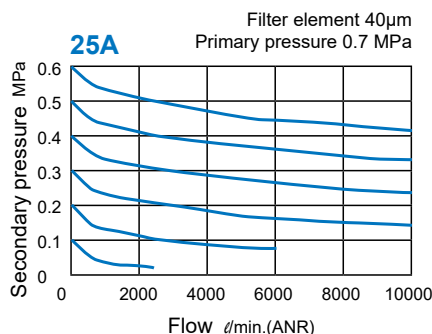
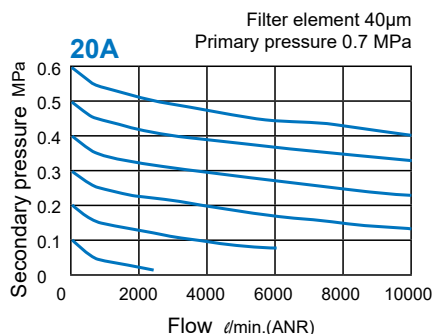

MACT501 Dimensions

AIR UNIT (F.R.L.UNIT)



Accessories

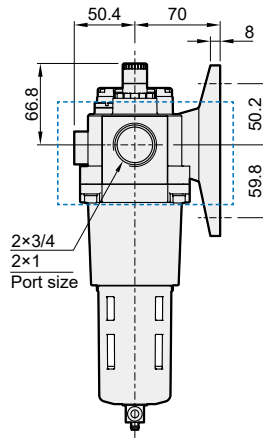
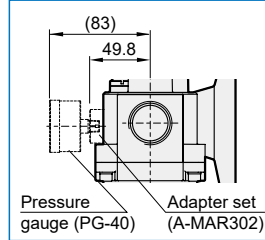

MACT501-D

Auto drain valve

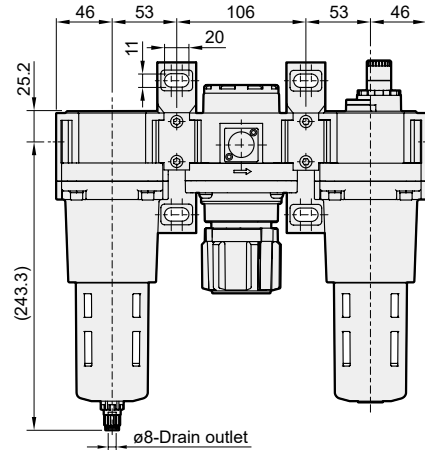

MACT501-T*

T type bracket

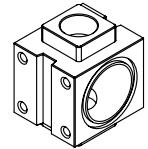
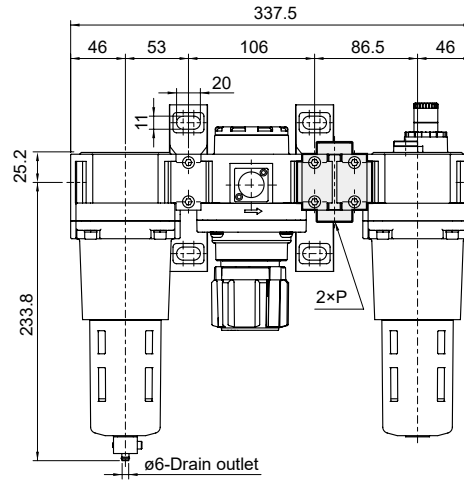

Port Bracket	P
T8	1/4
T10	3/8
T15	1/2

MACT501-M

Metal bowl

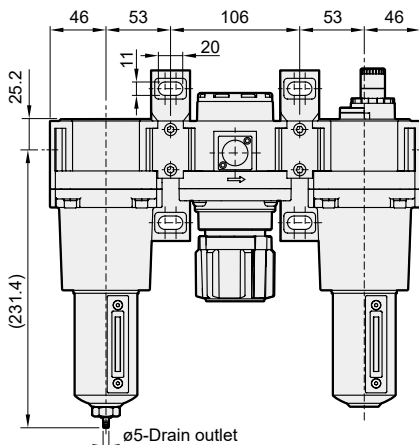
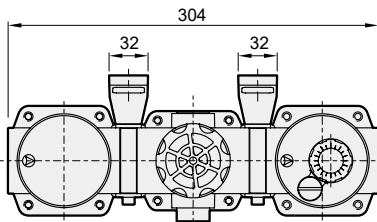

MACT501-MD

Metal bowl + auto drain valve

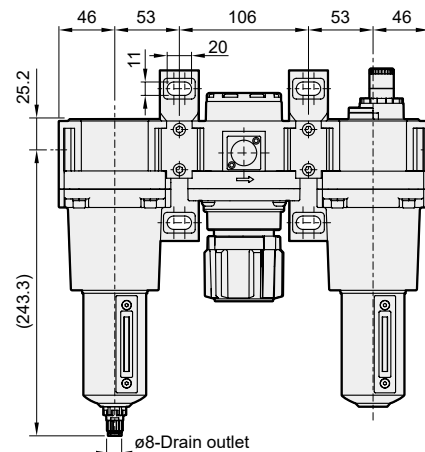
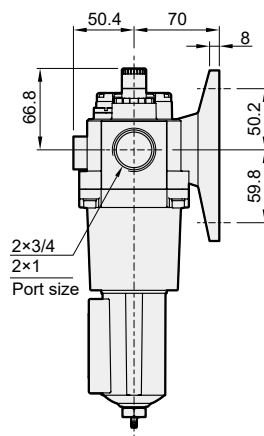

MAFR100 series

AIR UNIT (F.R.UNIT)



Technical data



Filter element



User manual



Caution for safety
(Read before installing)



Symbol

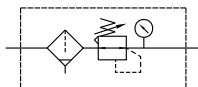

Specification

Model	MAFR100
Port size	M5×0.8
Medium	Air
Operating pressure range (*)	0.05~1 MPa
Proof pressure	1.5 MPa
Regulated pressure range	0.05~0.7 MPa
Ambient temperature	- 5~+60°C (No freez ing)
Filter element	Standard: 5µm, Option: 40µm
Drain capacity	3.5 cm ³
Attachment	Pressure gauge (PG-25), bracket
Weight	130 g

*Standard unit contains semi-auto-drain function when operating pressure below 0.05 MPa.

Order example

MAFR100 — M5 — □ — □

MODEL PORT SIZE FLOW DIRECTION FILTER ELEMENT

Blank: Left to right Blank: 5µm
R: Right to left 40u: 40µm

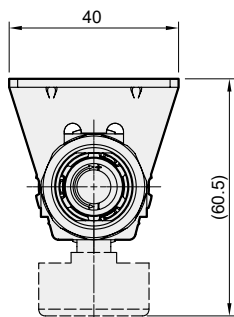

Panel mounting hole

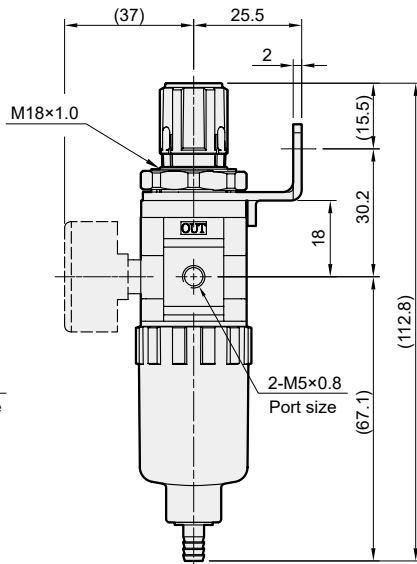
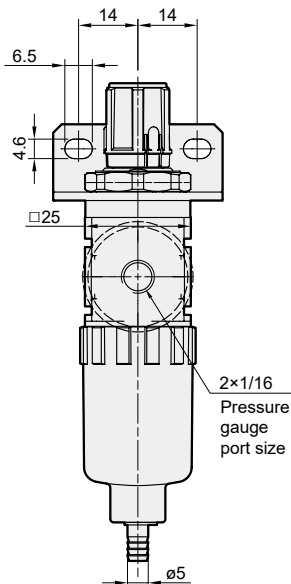
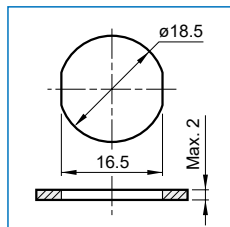

Flow feature

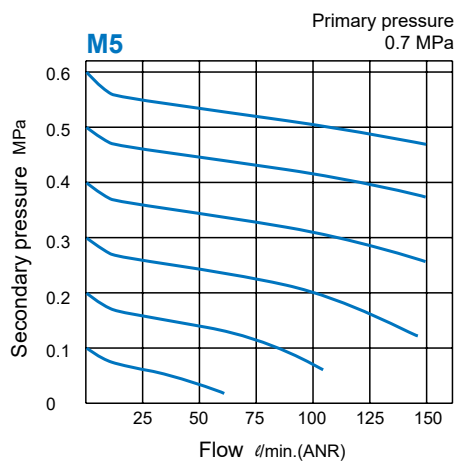

MAFR200 series

AIR UNIT (F.R.UNIT)



Technical data



Filter element



User manual



Caution for safety
(Read before installing)



Symbol

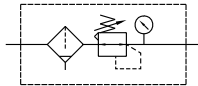

Specification

Model	MAFR200	
Bore No.	6A	8A
Port size	1/8	1/4
Medium	Air	
Operating pressure range (*)	0.05~1 MPa	
Proof pressure	1.5 MPa	
Regulated pressure range	Standard: 0.05~0.85 MPa	
Ambient temperature	- 5~+60°C (No freezing)	
Filter element	Standard: 40µm, Option: 5 µm	
Drain capacity	9.5 cm ³ , 25 cm ³ (MAFR200L)	
Attachment	Pressure gauge (PG-40), L-type bracket	
Weight	257 g, 226 g (MAFR200L)	

* Standard unit contains semi-auto-drain function when operating pressure below 0.05 MPa.

Order example

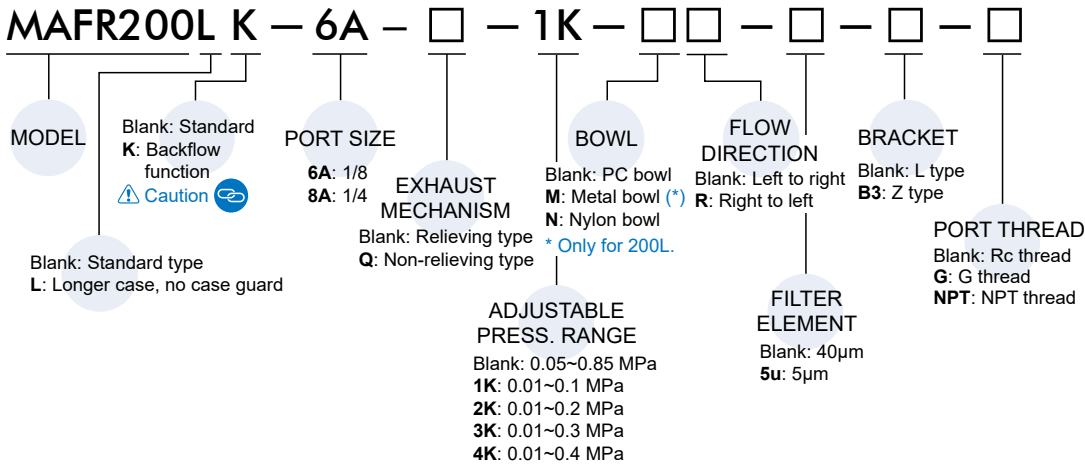

* Standard type regulator can not release the outlet pressure completely, even if inlet pressure was cut off, and the backflow function (K) must be applied to completely remove the residual pressure.

* The (Q) non-relieving type regulator is used. When the output pressure is higher than the set pressure, the output pressure will not flow out through the exhaust hole.

Flow feature

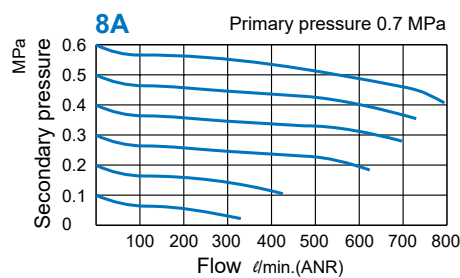
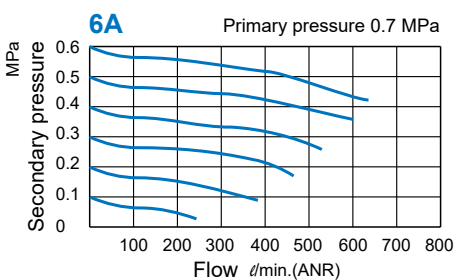

MAFR200 Dimensions

AIR UNIT (F.R.UNIT)



MAFR200-B3

Z type bracket

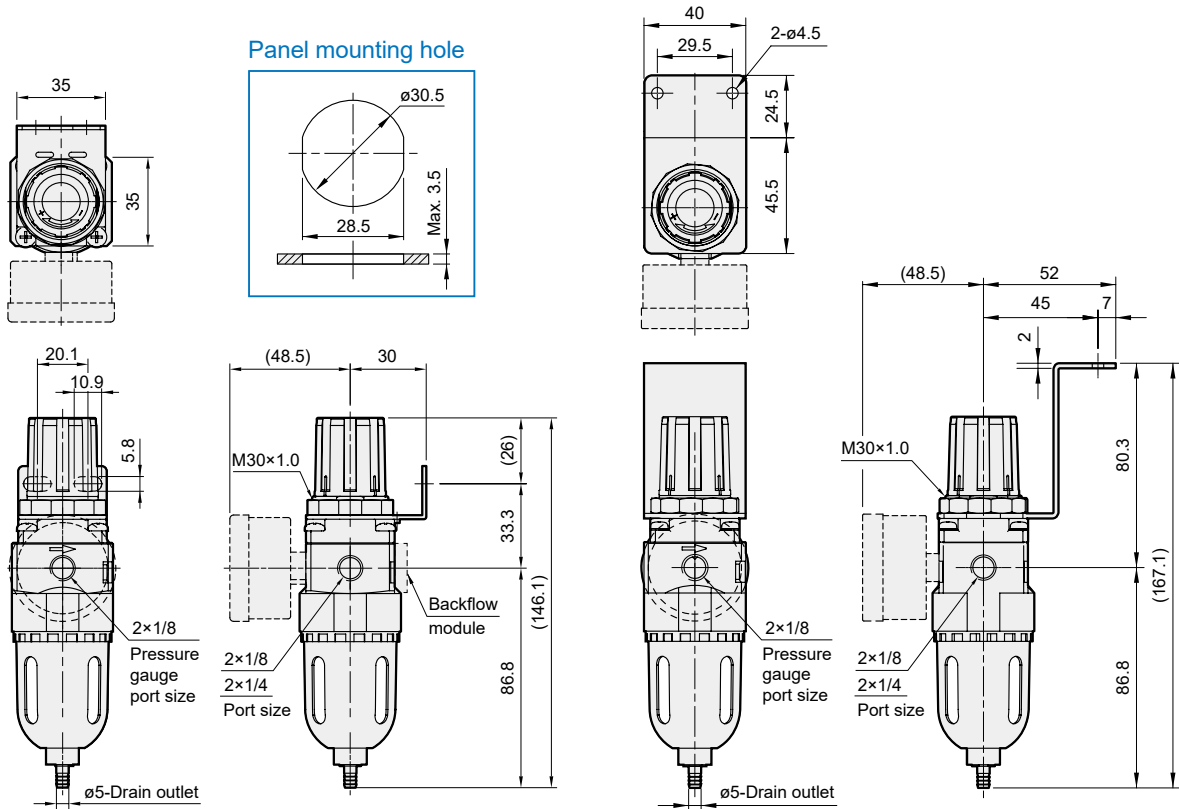

MAFR200L-M

Metal bowl + L type bracket

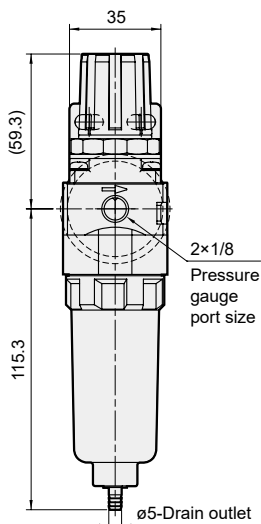

MAFR200L

L type bracket

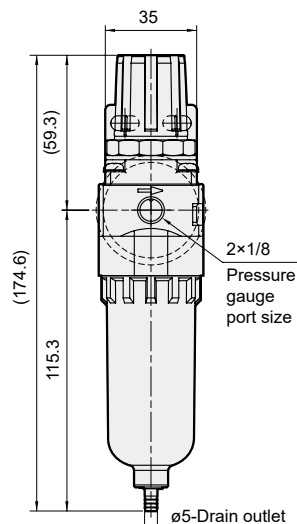

MAFR200L-B3

Z type bracket

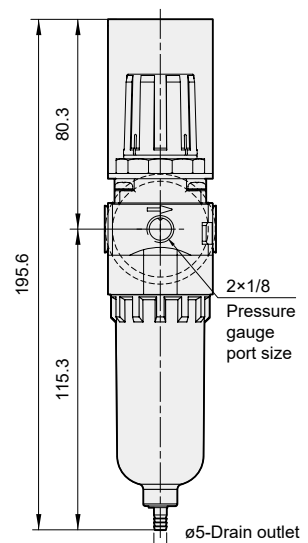

MAFR302 series

AIR UNIT (F.R.UNIT)



Technical data



Filter element



User manual



Caution for safety
(Read before installing)



Option: **MP41**

Symbol

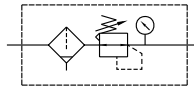

Specification

Model	MAFR302		
Bore No.	8A	10A	15A
Port size	1/4	3/8	1/2
Medium	Air		
Operating pressure range (*)	0.05~1 MPa		
Proof pressure	1.5 MPa		
Regulated pressure range	0.05~0.85 MPa		
Ambient temperature	- 5~+60°C (No freezing)		
Filter element	Standard: 5μm, Option: 40μm		
Drain capacity	35 cm ³		
Attachment	Pressure gauge (PG-20), L type bracket		
Weight	490 g		

* Standard unit contains semi-auto-drain function when operating pressure below 0.05 MPa.

* Choose auto-drain FMRF300, the pressure range is 0.15~1 MPa.

Order example

MAFR302 K - 8A - □ - NC□□ - E1 - □ - HR - □

MODEL

PORT SIZE

8A: 1/4
10A: 3/8
15A: 1/2

EXHAUST MECHANISM

Blank: Relieving type
Q: Non-relieving type

PRESSURE SWITCH

Blank: without
E1: MP41P-022
E2: MP41P-022-QD**
E5: MP41P-042
E6: MP41P-042-QD**

FILTER ELEMENT

Blank: 5μm
40u: 40μm

BRACKET
Blank: L type
B3: Z type

SHUTOFF VALVE

Blank: without
HR: MVHR-302-3H
1: MVHR-302S-3H-AC110
1L: MVHR-302S-3H-AC110-L
1E: MVHR-302S-3H-AC110-E
2: MVHR-302S-3H-AC220
2L: MVHR-302S-3H-AC220-L
2E: MVHR-302S-3H-AC220-E
4: MVHR-302S-3H-DC24
4L: MVHR-302S-3H-DC24-L
4E: MVHR-302S-3H-DC24-E

PORT THREAD
Blank: Rc thread
G: G thread
NPT: NPT thread

Blank: Standard

K: Backflow function ⚠ Caution

** MOQ required.
Please contact us.

T type bracket

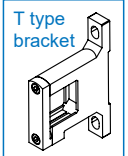

Bowl	Pressure gauge	Drain valve	Flow direction
Blank: PC bowl M: Metal bowl N: Nylon bowl	Blank: Pressure gauge (PG-20) C: External pressure gauge (PG-40) + Gauge adapter set (A-MAR302) A: Gauge adapter set (A-MAR302)	Blank: Semi-auto D: Auto (FMRF300)	Blank: Left to right R: Right to left

* Standard type regulator can not release the outlet pressure completely, even if inlet pressure was cut off, and the backflow function (K) must be applied to completely remove the residual pressure.

* The (Q) non-relieving type regulator is used. When the output pressure is higher than the set pressure, the output pressure will not flow out through the exhaust hole.

* PG-40 (C), A-MAR302 (A) and MP41 (E*) can not be selected at the same time.

* Be sure to use above check valves when redirecting the air flow on the inlet side of the lubricator.

Flow feature

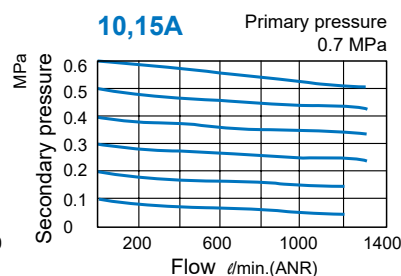
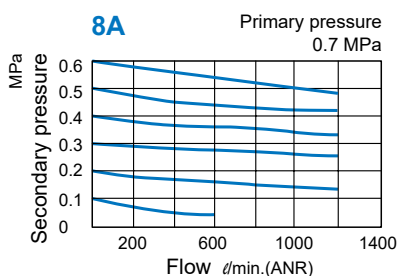

Caution

Metal bowl

Before assembling or disassembling, push the lock plate down to the end, and confirm that is detached from the body then rotate the bowl, otherwise the lock plate will be deformed or the body will be scratched.

1. Sliding plate down

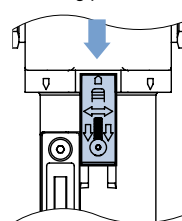

2. Rotating the bowl

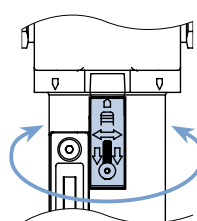

MAFR302 Dimensions

AIR UNIT (F.R.UNIT)



Panel mounting hole

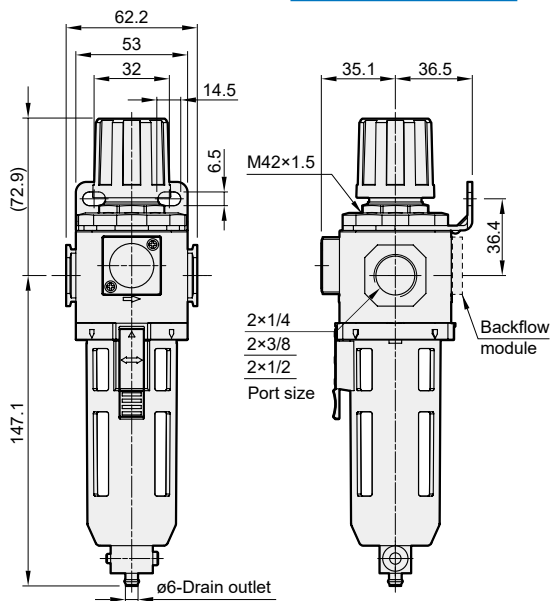
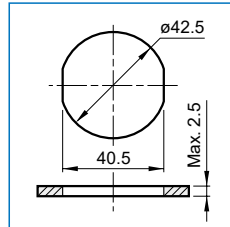

MAFR302-D

Auto drain valve

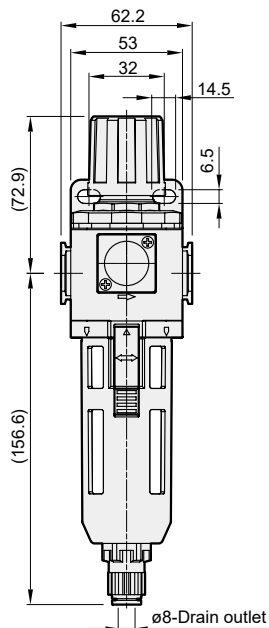

MAFR302-M

Metal bowl

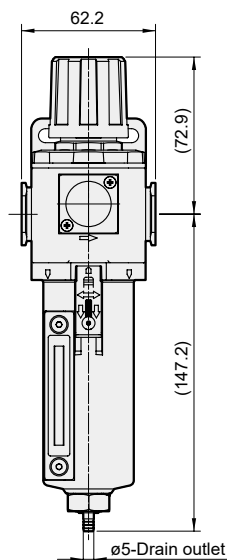

MAFR302-MD

Metal bowl + Auto drain valve

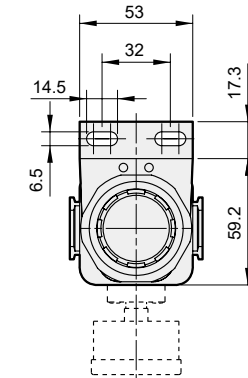
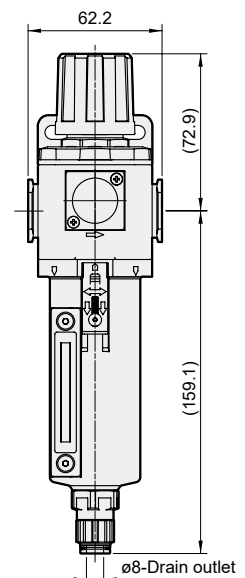

MAFR302-B3

Z type bracket

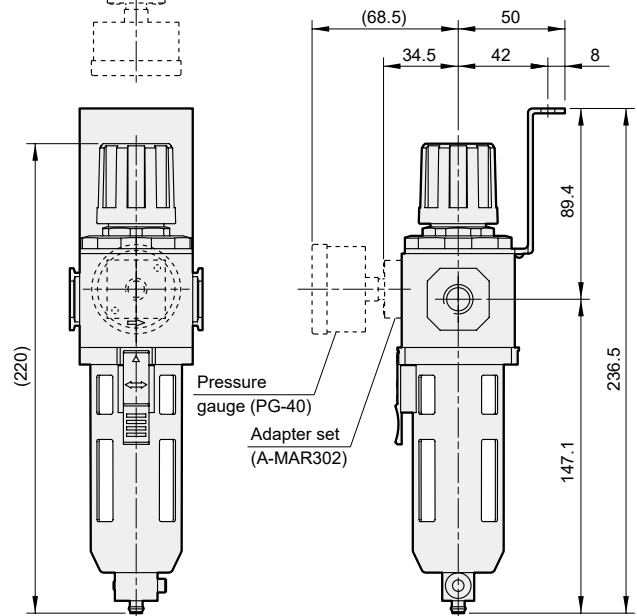

MAFR302-HR with shutoff valve

AIR UNIT (F.R.UNIT)



MAFR302-HR

With shutoff valve (MVHR-302)

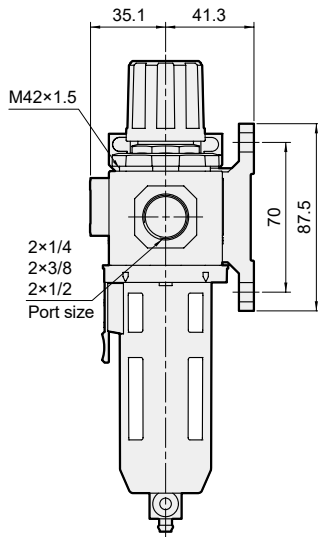
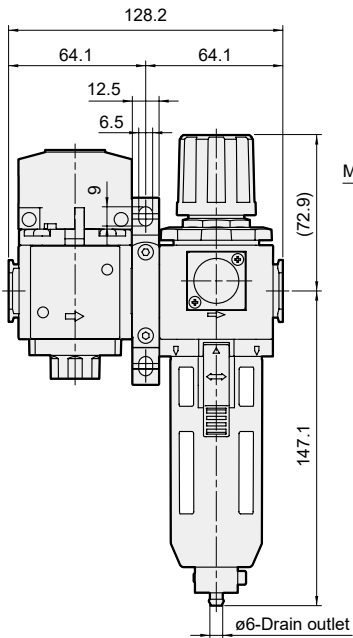

MAFR302-1*/2*/4*

With shutoff valve (MVHR-302S)

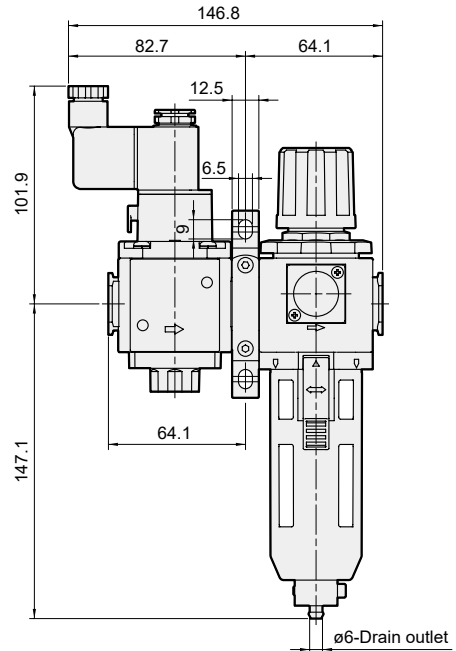

Accessories

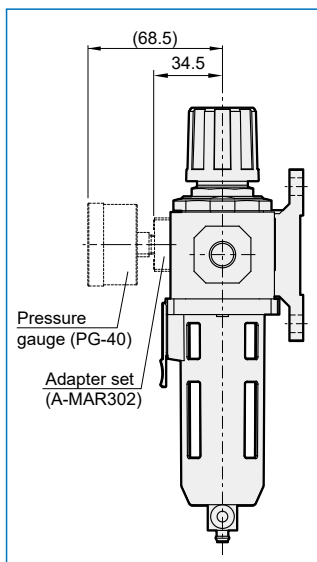

MAFR400 series

AIR UNIT (F.R.UNIT)



Technical data



Filter element



User manual



Caution for safety
(Read before installing)



Symbol

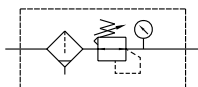

Specification

Model	MAFR400		
Bore No.	8A	10A	15A
Port size	1/4	3/8	1/2
Medium	Air		
Operating pressure range (*)	0.05~1 MPa		
Proof pressure	1.5 MPa		
Regulated pressure range	0.05~0.85 MPa		
Ambient temperature	- 5~+60°C (No freezing)		
Filter element	Standard: 40μm, Option: 5μm		
Drain capacity	100 cm ³		
Attachment	Pressure gauge (PG-50), bracket		
Weight	1350 g		

* Standard unit contains semi-auto-drain function when operating pressure below 0.05 MPa.

* Choose auto-drain FMRF300, the pressure range is 0.15~1 MPa.

Order example

MAFR400 - 8A - ND□ - □ - □

MODEL

8A: 1/4
10A: 3/8
15A: 1/2

BOWL
Blank: PC bowl
N: Nylon bowl

FLOW DIRECTION

Blank: Left to right
R: Right to left

FILTER ELEMENT

Blank: 40μm
5u: 5μm

DRAIN VALVE

Blank: Semi-auto
D: Auto (FMRF300)

PORT THREAD

Blank: Rc thread
G: G thread
NPT: NPT thread

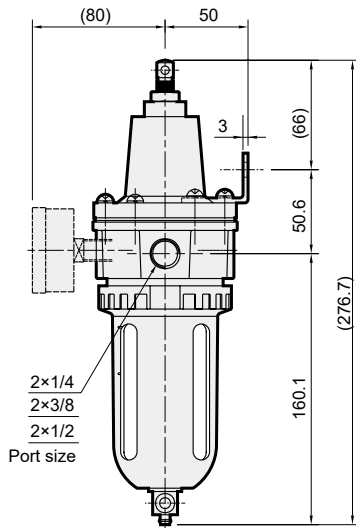
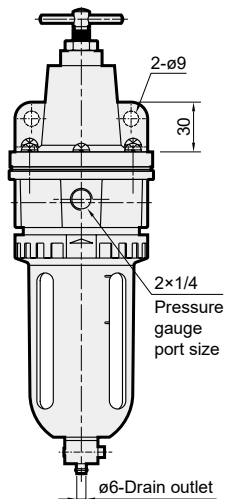
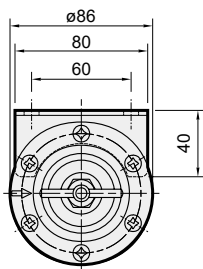

Flow feature

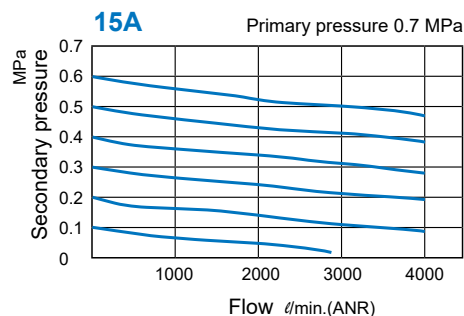
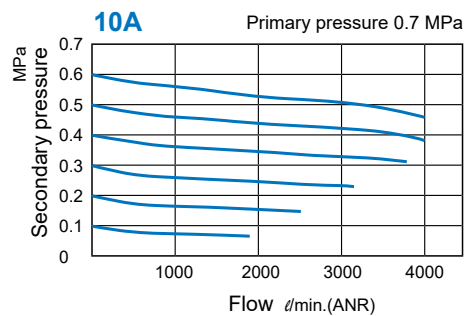
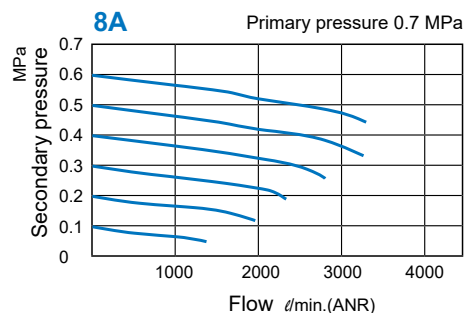

MAFR401 series

AIR UNIT (F.R.UNIT)



Technical data



Filter element



User manual



Caution for safety
(Read before installing)



Option: **MP41**

Symbol

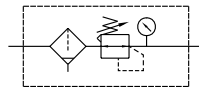

Specification

Model	MAFR401		
Bore No.	8A	10A	15A
Port size	1/4	3/8	1/2
Medium	Air		
Operating pressure range (*)	0.05~1.5 MPa		
Proof pressure	2 MPa		
Regulated pressure range	Standard type: 0.1~0.85 MPa		
	High pressure type: 0.1~1.5 MPa		
Ambient temperature	- 5~+60°C (No freezing)		
Filter element	Standard: 40µm, Option: 5µm		
Drain capacity	70 cm ³		
Attachment	Pressure gauge (PG-20)		
Weight	800 g		

* Standard unit contains semi-auto-drain function when operating pressure below 0.05 MPa.

* Choose auto-drain FMRF300, the pressure range is 0.15~1 MPa.

Order example

MAFR401 K - 8A - □ - □ - HA□P□ - E1 - □ - HR - □

MODEL

Blank: Standard
K: Backflow function
Caution

PORT SIZE

8A: 1/4
10A: 3/8
15A: 1/2

EXTERIOR COLOR

Blank: Black & silver
W: Gray & white

EXHAUST MECHANISM

Blank: Relieving type
Q: Non-relieving type

PRESSURE SWITCH

Blank: without
E1: MP41P-022
E2: MP41P-022-QD**
E5: MP41P-042
E6: MP41P-042-QD**
** MOQ required.
Please contact us.

FILTER ELEMENT

Blank: 40µm
5u: 5µm

BRACKET

Blank: without
B2: Screw fixed

PORT THREAD

Blank: Rc thread
G: G thread
NPT: NPT thread

SHUTOFF VALVE

Blank: without
HR: MVHR-400-3H
1: MVHR-400S-3H-AC110
1L: MVHR-400S-3H-AC110-L
2E: MVHR-400S-3H-AC220
2L: MVHR-400S-3H-AC220-L
4: MVHR-400S-3H-DC24
4L: MVHR-400S-3H-DC24-L
4E: MVHR-400S-3H-DC24-E

* 400: Manual type, 400S: Solenoid type
* Shutoff valve with L type bracket, no need to choose another bracket.
* MVHR series

Type	Pressure gauge	Drain valve	Pressure switch	Flow direction
Blank: Standard type	Blank: Pressure gauge (PG-20) C: External pressure gauge (PG-40) + Gauge adapter set (A-MAR401) A: Gauge adapter set (A-MAR401)	Blank: Semi-auto D: Auto (FMRF300)	Blank: without P: Pressure switch (MPS series)	Blank: Left to right R: Right to left
H: High pressure type	C: External pressure gauge (PG-40) + Gauge adapter set (A-MAR401) A: Gauge adapter set (A-MAR401)	Blank: Semi-auto	-	

* Standard type regulator can not release the outlet pressure completely, even if inlet pressure was cut off, and the backflow function (K) must be applied to completely remove the residual pressure.

* The (Q) non-relieving type regulator is used. When the output pressure is higher than the set pressure, the output pressure will not flow out through the exhaust hole.

* PG-40 (C), A-MAR302 (A) and MP41 (E*) can not be selected at the same time.

* Specification (W) gauge adapter set (A-MAR302).

* There is no pressure gauge in option (A), please purchase if necessary.

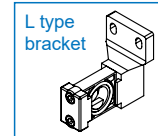

Flow feature

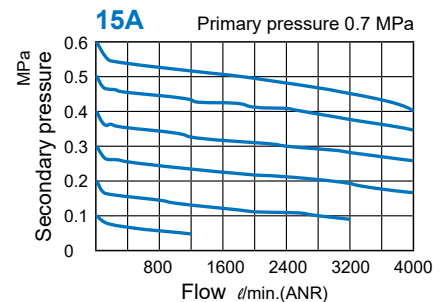
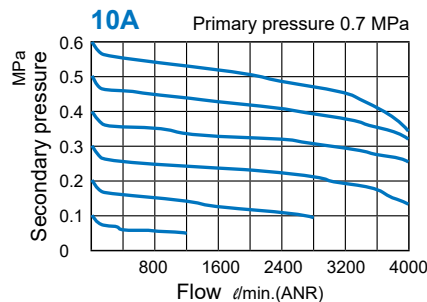
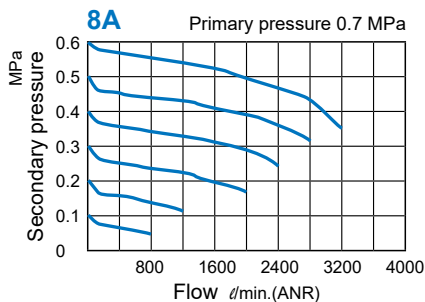

MAFR401 / MAFR401-HR Dimensions

AIR UNIT (F.R.UNIT)



Accessories

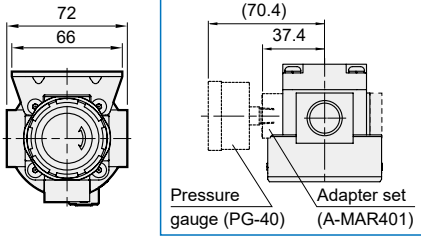

MAFR401-D

Auto drain valve

MAFR401-P

MPS Series
pneumatic pressure switch

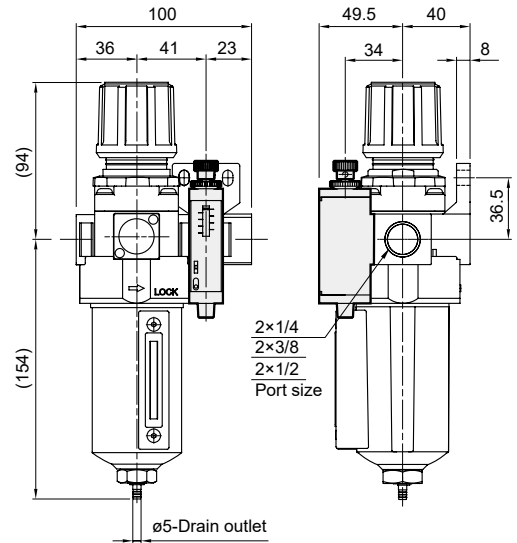
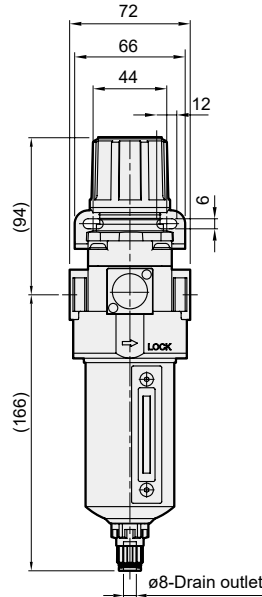
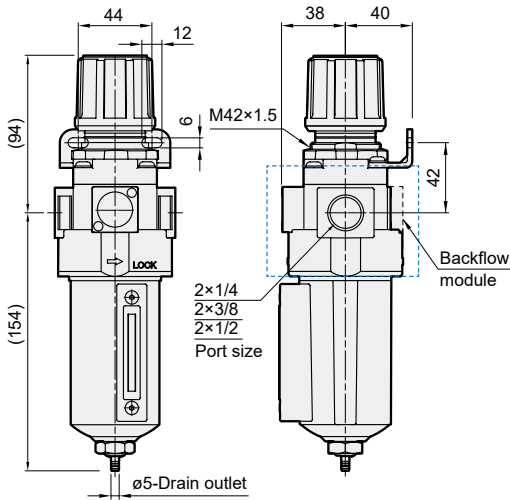

MAFR401-HR

With shutoff valve (MVHR-400)

MAFR401-1*/2*/4*

With shutoff valve (MVHR-400S)

Panel mounting hole

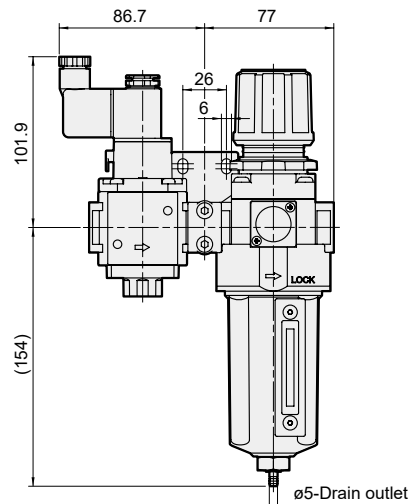
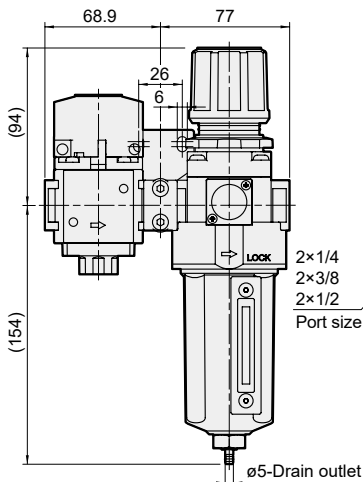
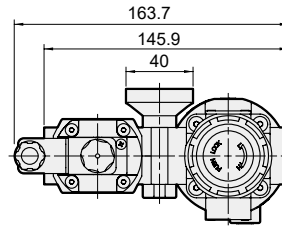
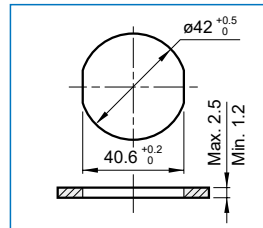
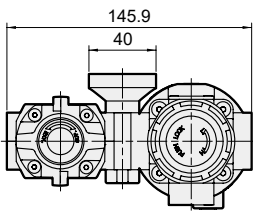

MAFR403 series

AIR UNIT (F.R.UNIT)



Technical data



Filter element



User manual



Caution for safety
(Read before installing)



Option: **MP41**

Specification

Model	MAFR403		
Bore No.	8A	10A	15A
Port size	1/4	3/8	1/2
Medium	Air		
Operating pressure range (*)	0.05~1 MPa		
Proof pressure	1.5 MPa		
Regulated pressure range	0.1~0.85 MPa		
Ambient temperature	- 5~+60°C (No freezing)		
Filter element	Standard: 40μm, Option: 5μm		
Drain capacity	75 cm ³		
Attachment	Pressure gauge (PG-20)		
Weight	620 g		

* Standard unit contains semi-auto-drain function when operating pressure below 0.05 MPa.

* Choose auto-drain FMRF300, the pressure range is 0.15~1 MPa.

Symbol

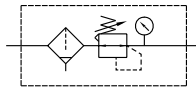

Order example

MAFR403 K - 8A - □ - NC□P□ - E1 - □ - HR - □

MODEL Blank: Standard K: Backflow function 	PORT SIZE 8A: 1/4 10A: 3/8 15A: 1/2	EXHAUST MECHANISM Blank: Relieving type Q: Non-relieving type	PRESSURE SWITCH Blank: without E1: MP41P-022 E2: MP41P-022-QD** E5: MP41P-042 E6: MP41P-042-QD** ** MOQ required. Please contact us.	FILTER ELEMENT Blank: 40μm 5u: 5μm	BRACKET Blank: without B2: Screw fixed	PORT THREAD Blank: Rc thread G: G thread NPT: NPT thread
			SHUTOFF VALVE Blank: without HR: MVHR-400-3H 1: MVHR-400S-3H-AC110 1L: MVHR-400S-3H-AC110-L 1E: MVHR-400S-3H-AC110-E 2: MVHR-400S-3H-AC220 2L: MVHR-400S-3H-AC220-L 2E: MVHR-400S-3H-AC220-E 4: MVHR-400S-3H-DC24 4L: MVHR-400S-3H-DC24-L 4E: MVHR-400S-3H-DC24-E			

Bowl	Pressure gauge	Drain valve	Pressure switch	Flow direction
Blank: PC bowl N: Nylon bowl	Blank: Pressure gauge (PG-20) C: External pressure gauge (PG-40) + Gauge adapter set (A-MAR302) A: Gauge adapter set (A-MAR302)	Blank: Semi-auto D: Auto (FMRF300)	Blank: without P: Pressure switch (MPS series)	Blank: L: Left to right R: Right to left

* Standard type regulator can not release the outlet pressure completely, even if inlet pressure was cut off, and the backflow function (K) must be applied to completely remove the residual pressure.

* The (Q) non-relieving type regulator is used. When the output pressure is higher than the set pressure, the output pressure will not flow out through the exhaust hole.

* PG-40 (C), A-MAR302 (A) and MP41 (E*) can not be selected at the same time.

* There is no pressure gauge in option (A), please purchase if necessary.

* 400: Manual type, 400S: Solenoid type

* Shutoff valve with L type bracket, no need to choose another bracket.

* MVHR series

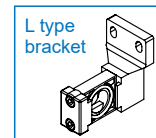

Flow feature

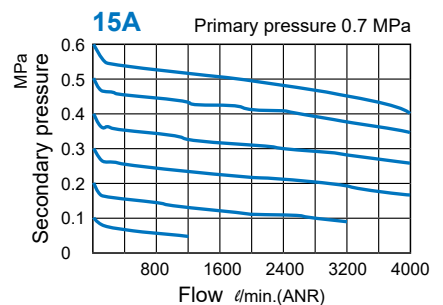
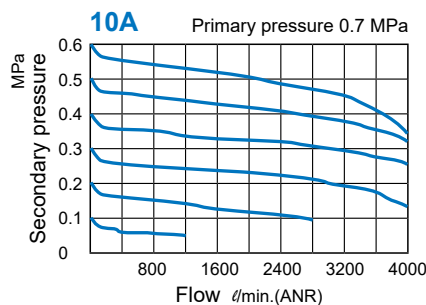
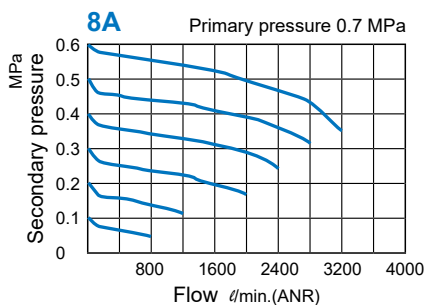

MAFR403 / MAFR403-HR Dimensions

AIR UNIT (F.R.UNIT)



Accessories

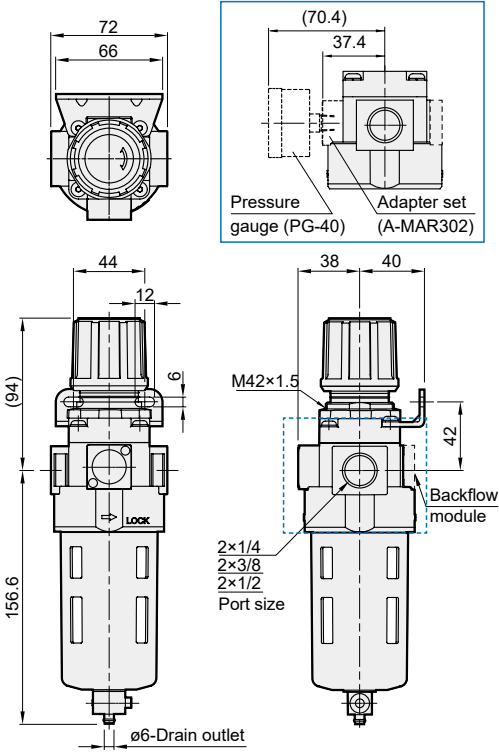

MAFR403-D

Auto drain valve

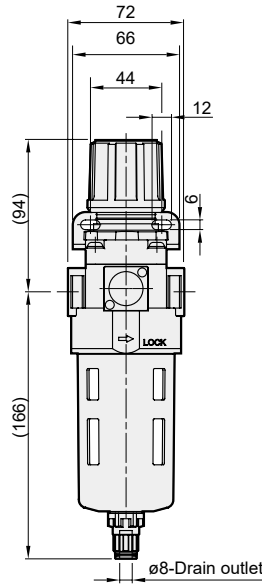

MAFR403-P

MPS Series
pneumatic pressure switch

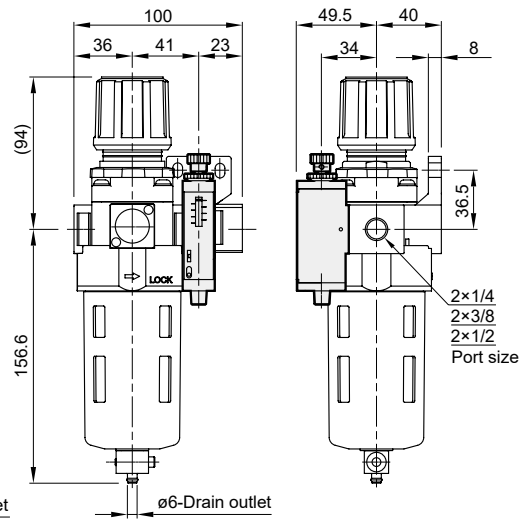

MAFR403-HR

With shutoff valve (MVHR-400)

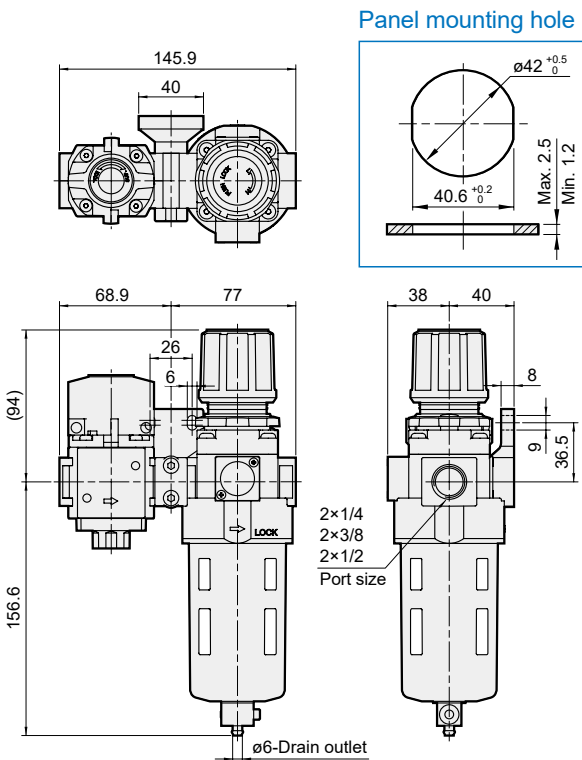

MAFR403-1*1/2*/4*

With shutoff valve (MVHR-400S)

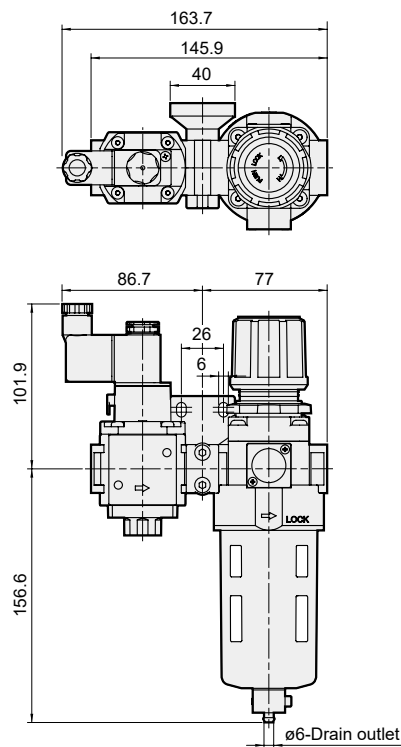

MAFR501 series

AIR UNIT (F.R.UNIT)



Technical data



Filter element



User manual



Caution for safety
(Read before installing)



Option: **MP41**

Symbol

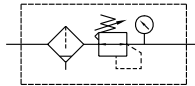

Specification

Model	MAFR501	
Bore No.	20A	25A
Port size	3/4	1
Medium	Air	
Operating perssure range (*)	Nylon bowl, PC bowl: 0.05~1 MPa	
	Metal bowl: 0.05~1.5 MPa	
Proof pressure	Nylon bowl, PC bowl: 1.5 MPa	
	Metal bowl: 2 MPa	
Regulated pressure range	0.1~0.85 MPa	
Ambient temperature	- 5~+60°C (No freezing)	
Filter element	40µm	
Drain capacity	PC, Nylon bowl: 75 cm ³	
	Metal bowl: 70 cm ³	
Attachment	Pressure gauge(PG-20), L-type bracket	
Weight	PC, Nylon bowl: 1940 g	
	Metal bowl: 2060 g	

* Standard unit contains semi-auto-drain function when operating pressure below 0.05 MPa.

* Choose auto-drain FMRF300, the pressure range is 0.15~1 MPa.

Order example

MAFR501 – 20A – MC□J□ – E1 – □

MODEL

PORT SIZE

20A: 3/4
25A: 1

PRESSURE SWITCH

Blank: without
E1: MP41P-022
E2: MP41P-022-QD**
E5: MP41P-042
E6: MP41P-042-QD**

** MOQ required. Please contact us.

PORT THREAD

Blank: Rc thread
G: G thread
NPT: NPT thread

Bowl	Pressure gauge	Drain valve	Panel nuts	Flow direction
Blank: PC bowl M: Metal bowl N: Nylon bowl	Blank: Pressure gauge (PG-20) C: External pressure gauge (PG-40) + Gauge adapter set (A-MAR302) A: Gauge adapter set (A-MAR302)	Blank: Semi-auto D: Auto (FMRF300)	Blank: without J: Panel nuts	Blank: Left to right R: Right to left

* PG-40 (C), A-MAR302 (A) and MP41 (E*) can not be selected at the same time.

Flow feature

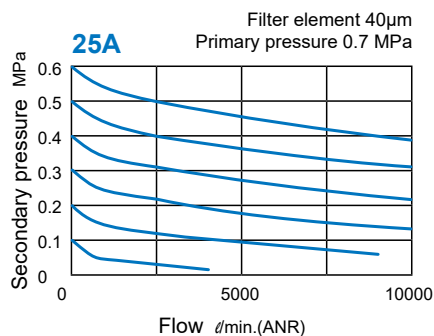
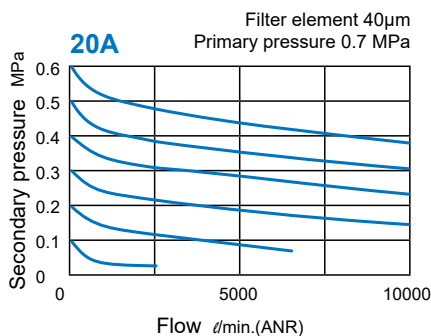

MAFR501 Dimensions

AIR UNIT (F.R.UNIT)



Panel mounting hole

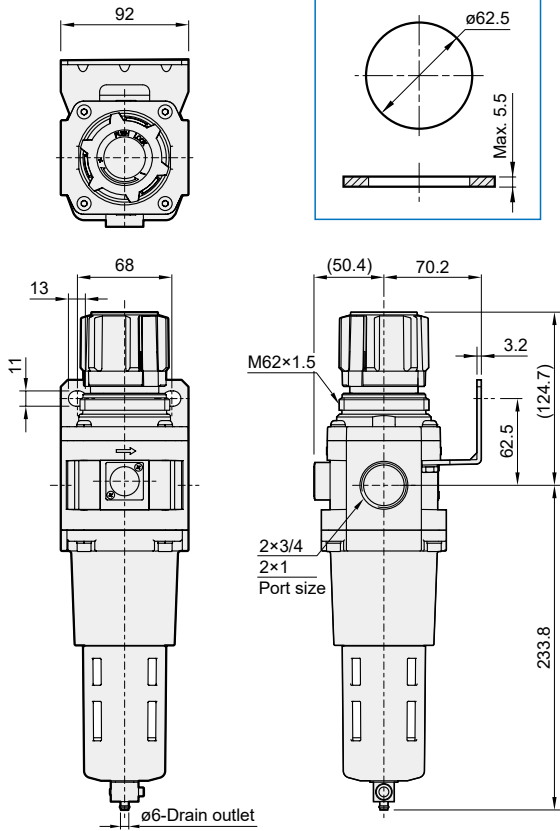

Accessories

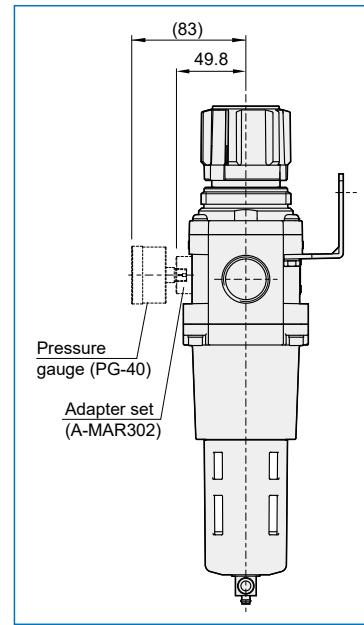

MAFR501-D

Auto drain valve

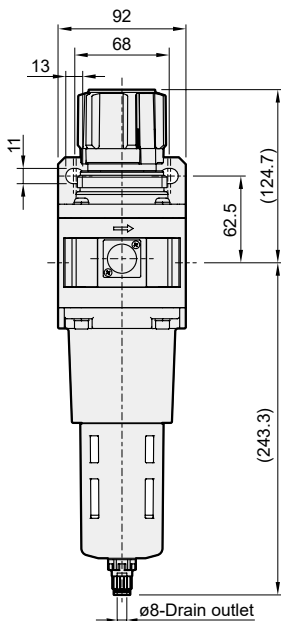

MAFR501-MD

Metal bowl + auto drain valve

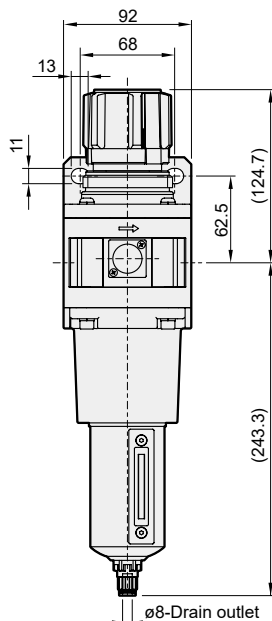

MAFR501-M

Metal bowl

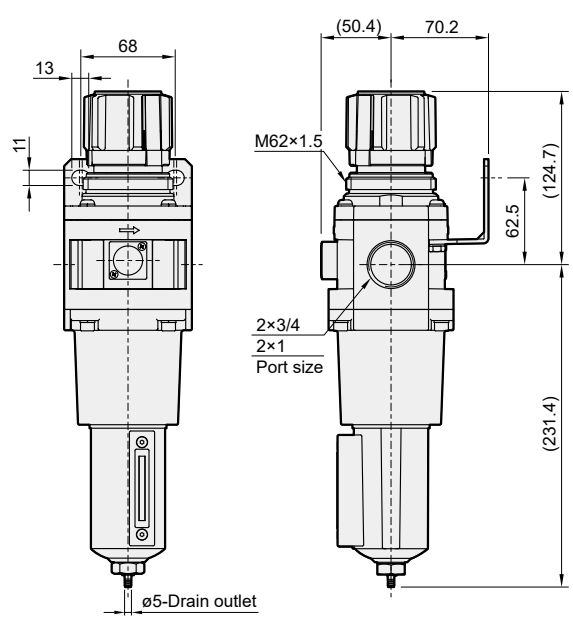

MAF200 series

AIR UNIT (FILTER)



Technical data



Filter element



User manual



Caution for safety
(Read before installing)



Symbol

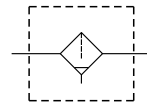

Specification

Model	MAF200	
Bore No.	6A	8A
Port size	1/8	1/4
Medium	Air	
Operating pressure range (*)	0.05~1 MPa	
Proof pressure	1.5 MPa	
Ambient temperature	- 5~+60°C (No freezing)	
Filter element	Standard: 40µm, Option: 5µm	
Drain capacity	9.5 cm ³ , 25 cm ³ (MAF200L)	
Weight	187 g, 155 g (MAF200L)	

* Standard unit contains semi-auto-drain function when operating pressure below 0.05 MPa.

Order example

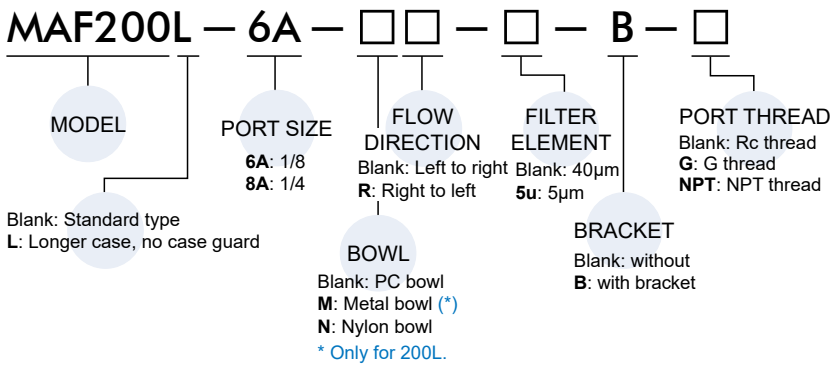

Flow feature

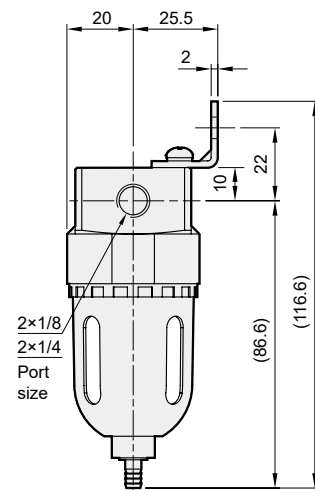
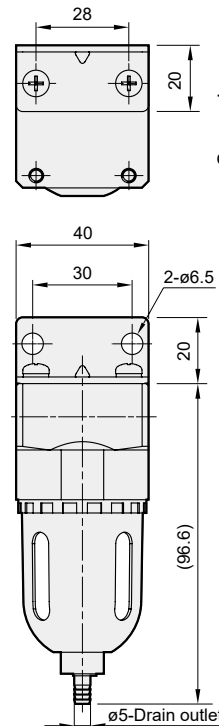
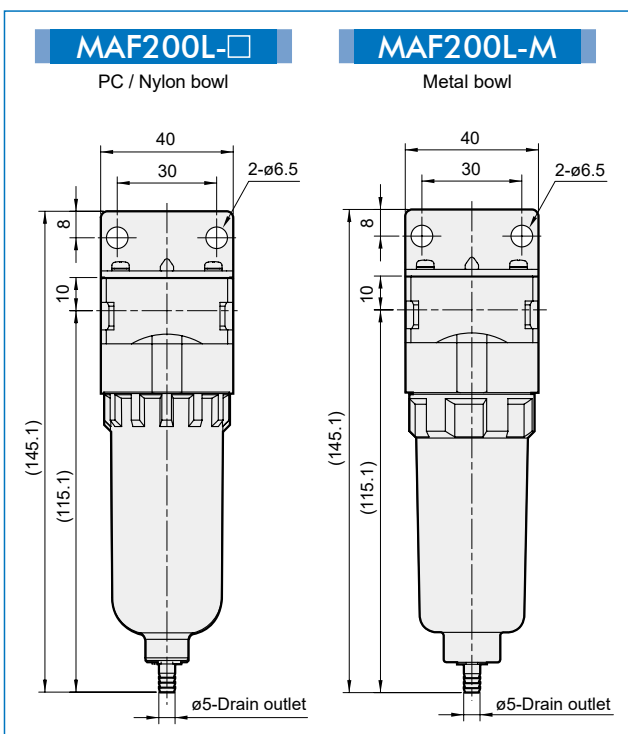
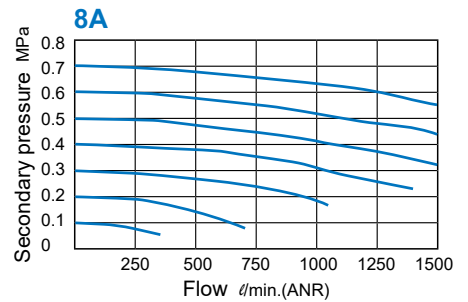
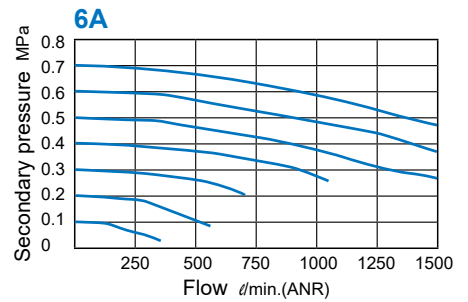

MAF302 series

AIR UNIT (FILTER / WATER SEPARATOR)



Technical data



Filter element



User manual



Caution for safety
(Read before installing)



Symbol

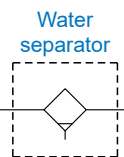
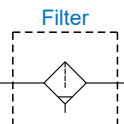

Specification

Model	MAF302		
Bore No.	8A	10A	15A
Port size	1/4	3/8	1/2
Medium	Air		
Operating perssure range (*1)	0.05~1 MPa		
Proof pressure	1.5 MPa		
Ambient temperature	- 5~+60°C (No freezing)		
Drain capacity	35 cm ³		

Filter	MAF302	
Filter element	Standard: 5μm, Option: 40μm	
Weight	335 g	
Water separator	MAF302G	
Water droplet removal ratio (*2)	99±1%	
Rated flow l/min(ANR) (*3)	550	1280
Weight	345 g	

Order example

MAF302G – 8A – ND □ – □ – □ – □

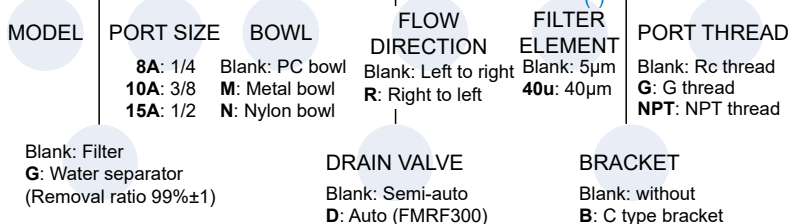

* There is not filter element in MAF302G series.

- *1. Standard unit contains semi-auto-drain function when operating pressure below 0.05 MPa. Choose auto-drain FMRF300, the pressure range is 0.15~1 MPa.
- *2. This shows the water droplet removal ratio at the rated flow.
- *3. Input pressure: 0.7 MPa. When fluid flows exceeding the rated flow, the accumulated condensate may be pulled up and may flow out to outlet side.

Water separator features

- Water droplets are removed by centrifugal force. This product can remove water droplets in the compressed air, but cannot remove moisture content (water vapor).
- Filter element is not needed. Water droplet removal ratio: 99%

Flow feature

MAF302 (Filter)

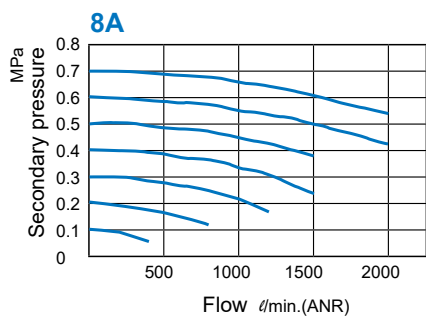

MAF302G (Water separator)

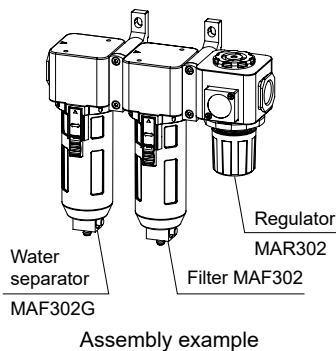
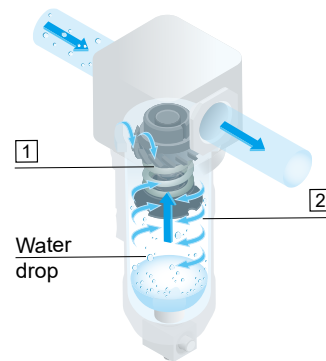
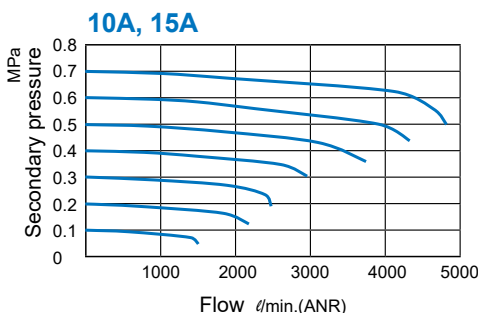
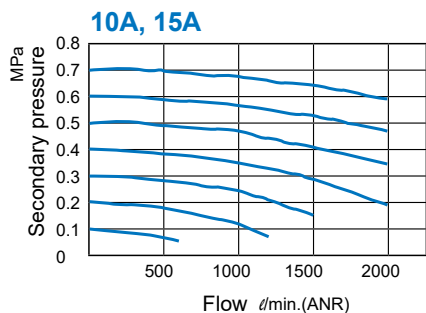
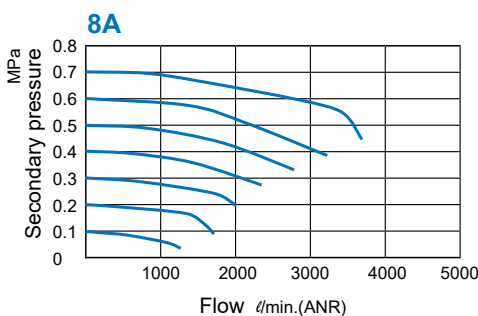

MAF302 Dimensions

AIR UNIT (FILTER / WATER SEPARATOR)

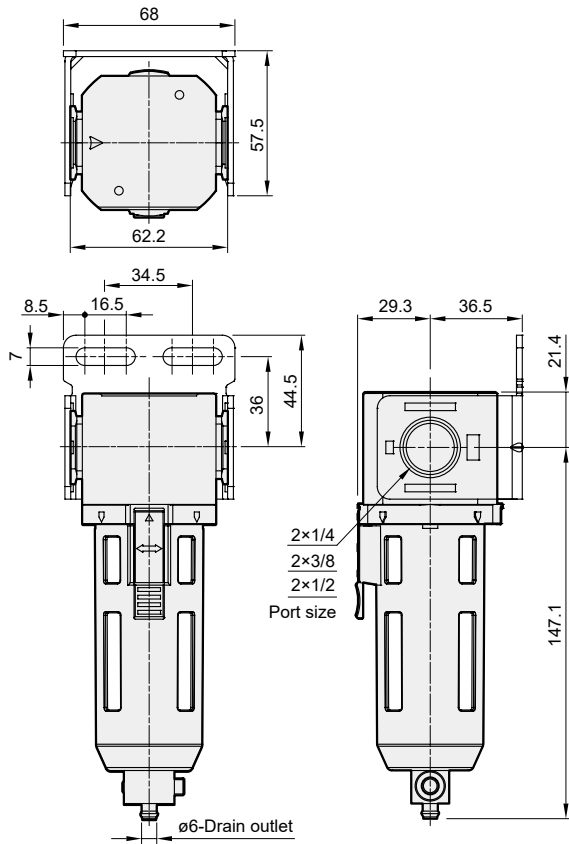

Option accessories

C type bracket

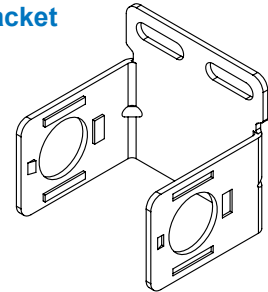

! Caution

Metal bowl

Before assembling or disassembling, push the lock plate down to the end, and confirm that it is detached from the body then rotate the bowl, otherwise the lock plate will be deformed or the body will be scratched.

1. Sliding plate down

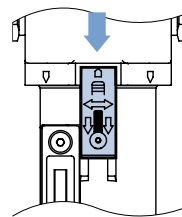

2. Rotating the bowl

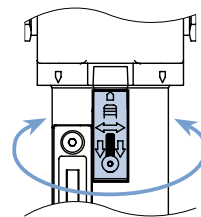

MAF302-D

Auto drain valve

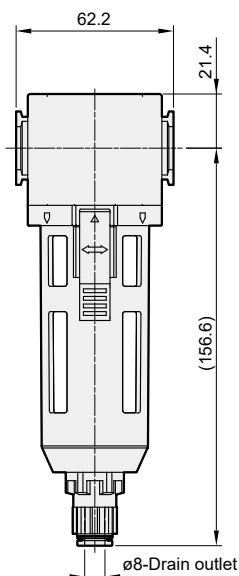

MAF302-M

Metal bowl

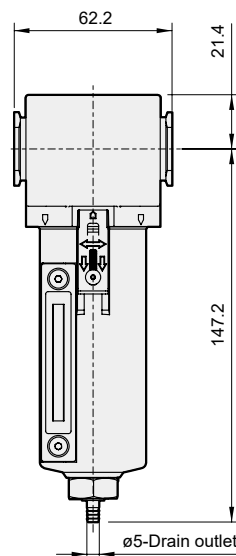

MAF302-MD

Metal bowl + Auto drain valve

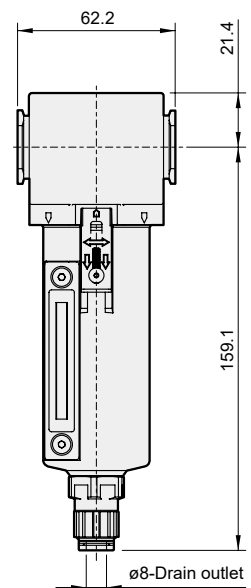

MAFV302 series

AIR UNIT (VACUUM FILTER)



Technical data



Filter element



Caution for safety
(Read before installing)



Symbol

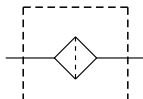

Features

- Remove water droplets and pollutants to ensure the quality of the vacuum gas supply system.
- The maximum flow rate is 240 L/min when the initial pressure loss is 4 kPa.
- Nylon cup body to adapt to a variety of environment needs.

Specification

Model	MAFV302		
Bore No.	8A	10A	15A
Port size	1/4	3/8	1/2
Medium	Air		
Operating pressure range	-100~0 kPa		
Proof pressure	0.5 MPa		
Ambient temperature	- 5~+60°C (No freezing)		
Drain capacity	35 cm ³		
Filter element	5μm		
Weight	333 g		

Order example

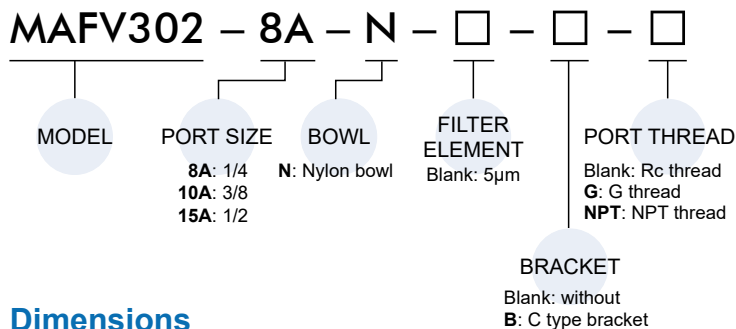

Dimensions

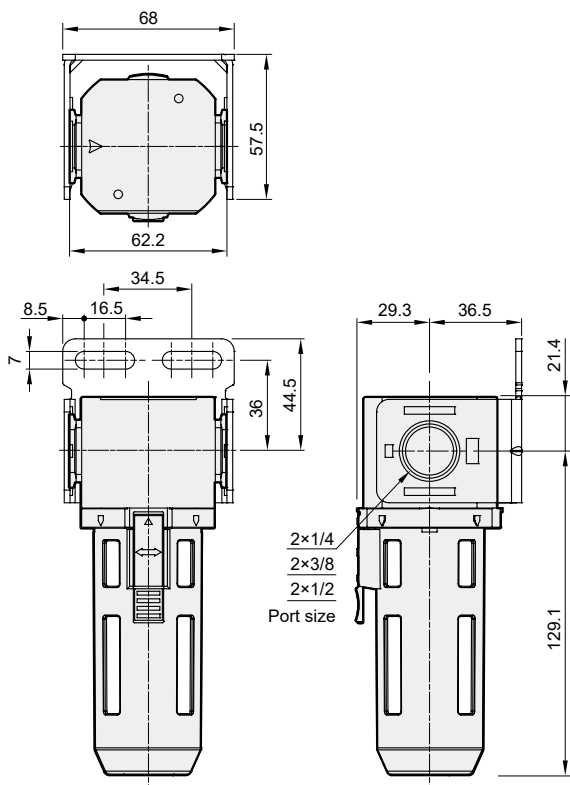

Flow feature

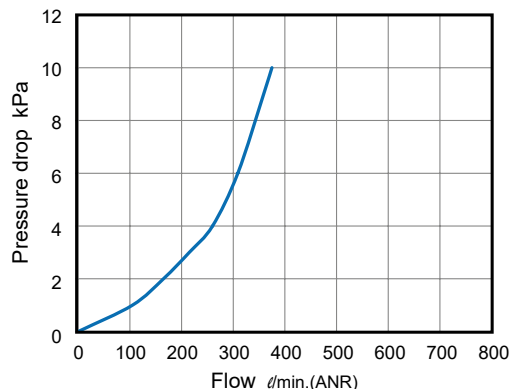

Option accessories

C type bracket

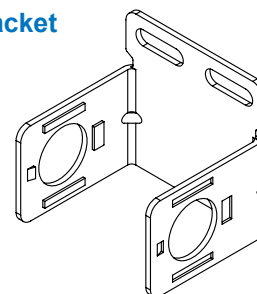

MAF400 series

AIR UNIT (FILTER)



Technical data



Filter element



User manual



Caution for safety
(Read before installing)



Symbol

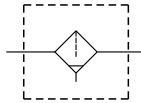

Specification

Model	MAF400		
Bore No.	8A	10A	15A
Port size	1/4	3/8	1/2
Medium	Air		
Operating pressure range (*1.2)	0.05~1 MPa		
Proof pressure	1.5 MPa		
Ambient temperature	- 5~+60°C (No freezing)		
Filter element	Standard: 40μm, Option: 5μm		
Drain capacity	100 cm ³		
Max. flow rate(*3) ℓ/min(ANR)	1500	2000	2200
Weight	550 g		

*1. Standard unit contains semi-auto-drain function when operating pressure below 0.05 MPa.

*2. Choose auto-drain FMRF300, the pressure range is 0.15~1 MPa.

*3. Flow is at pressure P=0.7 MPa with pressure drop ΔP=0.03 MPa.

Order example

MAF400 – 8A – ND – – **B** –

MODEL

PORT SIZE

BOWL

FLOW DIRECTION

FILTER ELEMENT

BRACKET

PORT THREAD

8A: 1/4
10A: 3/8
15A: 1/2

Blank: PC bowl
N: Nylon bowl

Blank: Left to right
R: Right to left

Blank: 40μm
5u: 5μm

Blank: without
B: with bracket

Blank: Rc thread
G: G thread
NPT: NPT thread

DRAIN VALVE

Blank: Semi-auto
D: Auto (FMRF300)

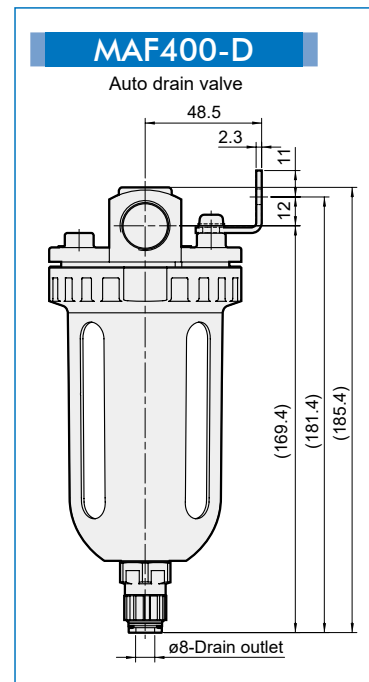
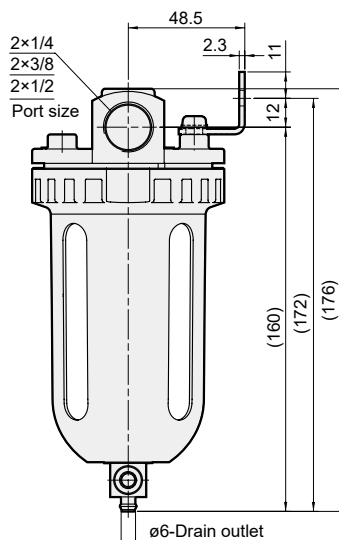
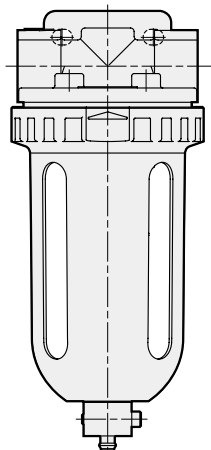
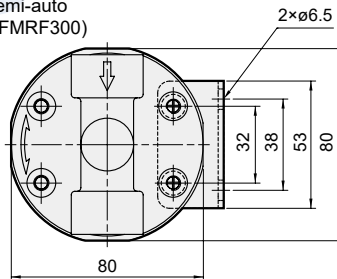

MAF401 series

AIR UNIT (FILTER)



Technical data



Filter element



User manual



Caution for safety
(Read before installing)



Specification

Model	MAF401		
Bore No.	8A	10A	15A
Port size	1/4	3/8	1/2
Medium	Air		
Operating pressure range (*1,2)	0.05~1.5 MPa		
Proof pressure	2 MPa		
Ambient temperature	-5~+60°C (No freezing)		
Filter element	Standard: 40µm, Option: 5µm		
Drain capacity	70 cm ³		
Max. flow rate(*3) ℓ /min(ANR)	1500	2000	2500
Weight	480 g		

Symbol

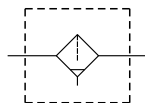

Order example

MAF401 - 8A - □ - D □ - □ - □ - □

MODEL

PORT SIZE

8A: 1/4
10A: 3/8
15A: 1/2

EXTERIOR COLOR

Blank: Black & silver
W: Gray & white

FLOW DIRECTION

Blank: Left to right
R: Right to left

DRAIN VALVE

Blank: Semi-auto
D: Auto (FMRF300)

BRACKET

Blank: without
B: C type bracket

FILTER ELEMENT

Blank: 40µm
5u: 5µm

PORT THREAD

Blank: Rc thread
G: G thread
NPT: NPT thread

Option accessories

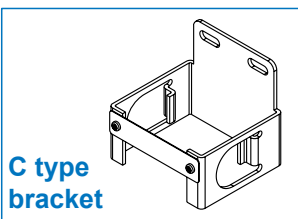

MAF401-D

Auto drain valve

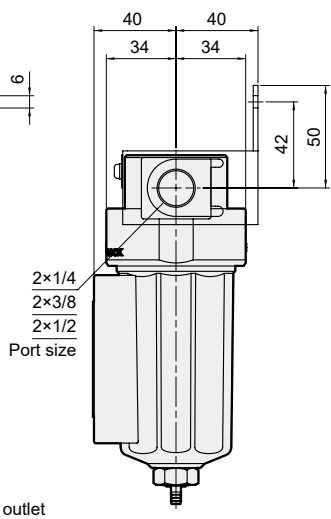
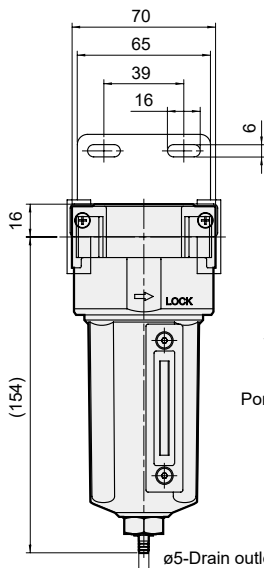
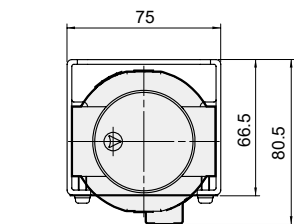
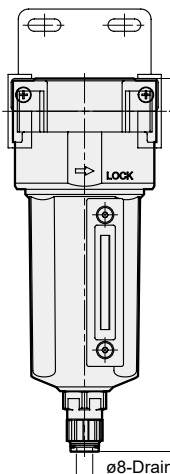

Flow feature

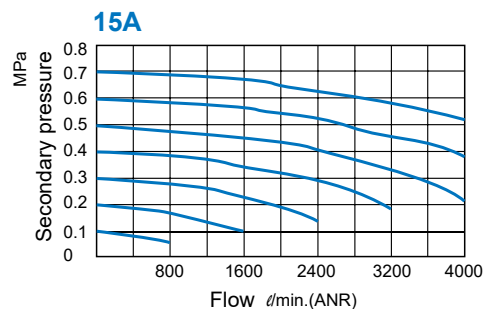
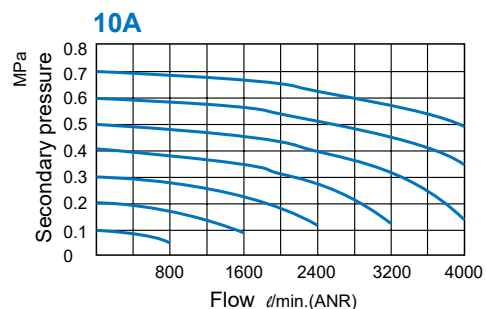
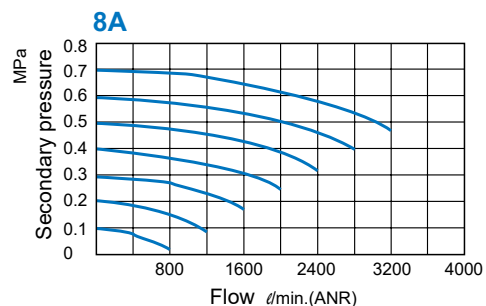

MAF403 series

AIR UNIT (FILTER)



Technical data



Filter element



User manual



Caution for safety
(Read before installing)



Symbol

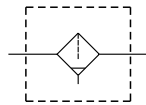

Specification

Model	MAF403		
Bore No.	8A	10A	15A
Port size	1/4	3/8	1/2
Medium	Air		
Operating pressure range (*)	0.05~1 MPa		
Proof pressure	1.5 MPa		
Ambient temperature	- 5~+60°C (No freezing)		
Filter element	Standard: 40μm, Option: 5μm		
Drain capacity	75 cm ³		
Weight	345 g		

* Standard unit contains semi-auto-drain function when operating pressure below 0.05 MPa.

* Choose auto-drain FMRF300, the pressure range is 0.15~1 MPa.

Order example

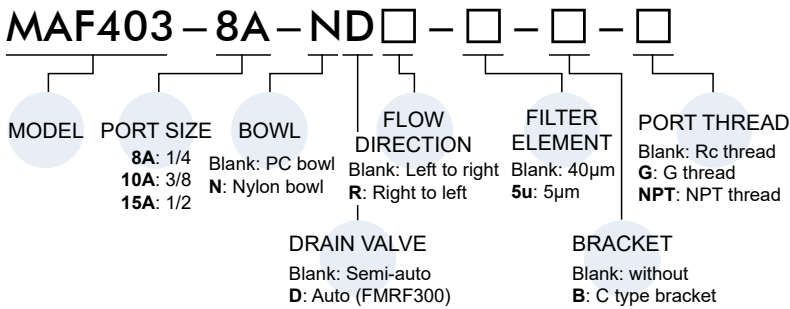

Flow feature

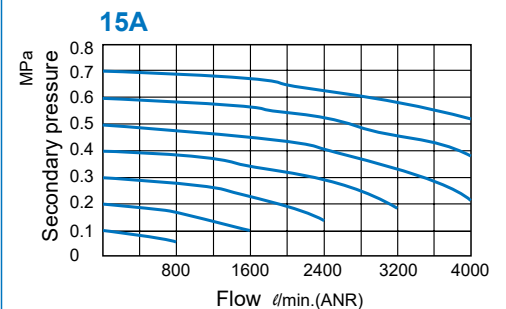
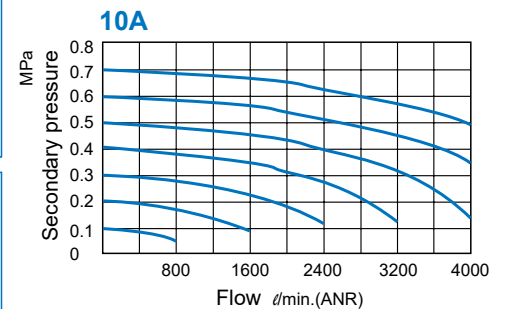
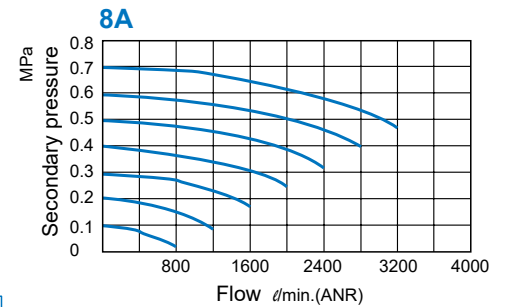

Option accessories

C type bracket

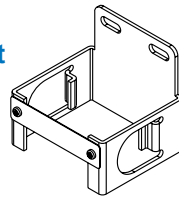

MAF403-D

Auto drain valve

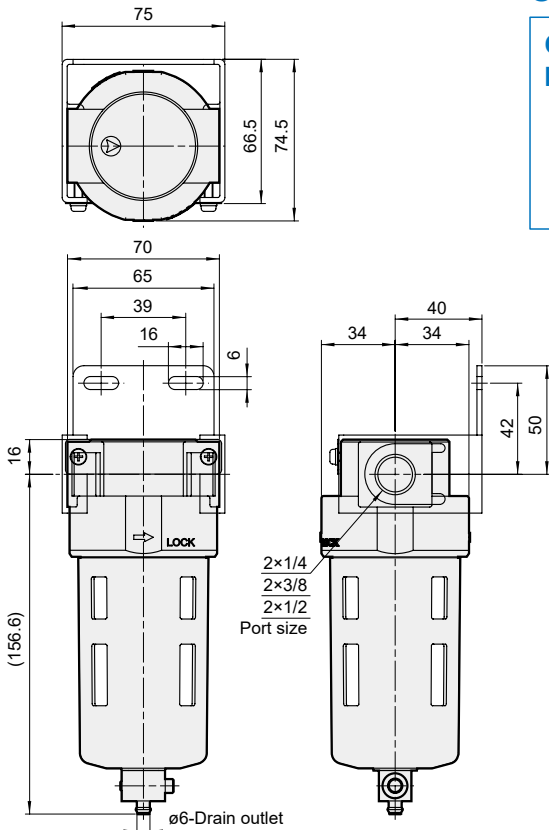
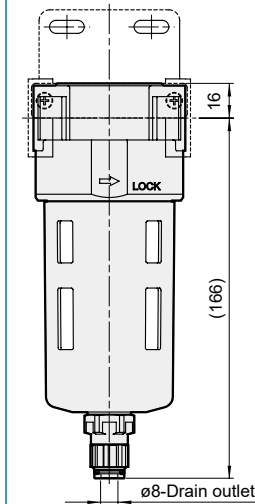

MAF501 series

AIR UNIT (FILTER)



Technical data



Filter element



User manual



Caution for safety
(Read before installing)



Symbol

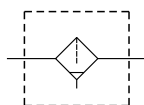

Specification

Model	MAF501	
Bore No.	20A	25A
Port size	3/4	1
Medium	Air	
Operating perssure range (*)	Nylon bowl, PC bowl: 0.05~1 MPa	
	Metal bowl: 0.05~1.5 MPa	
Proof pressure	Nylon bowl, PC bowl: 1.5 MPa	
	Metal bowl: 2 MPa	
Ambient temperature	- 5~+60°C (No freezing)	
Filter element	40 μm	
Drain capacity	Nylon bowl, PC bowl: 75 cm ³	
	Metal bowl: 70 cm ³	
Weight	Nylon bowl, PC bowl: 1180g	
	Metal bowl: 1300g	

* Standard unit contains semi-auto-drain function when operating pressure below 0.05 MPa.

* Choose auto-drain FMRF300, the pressure range is 0.15~1 MPa.

Order example

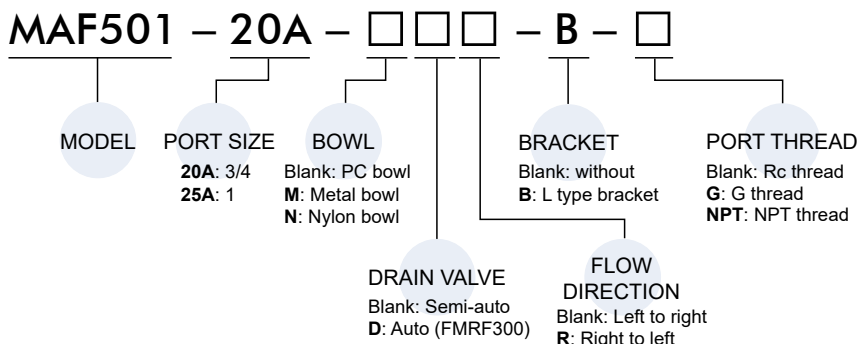

Option accessories

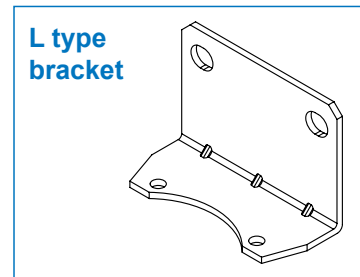

Flow feature

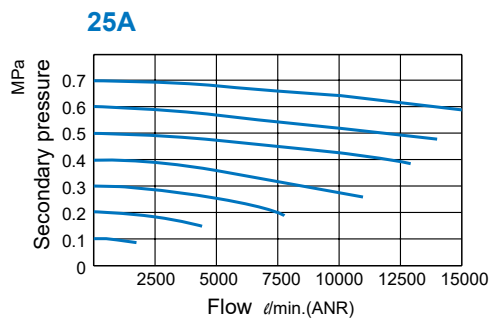
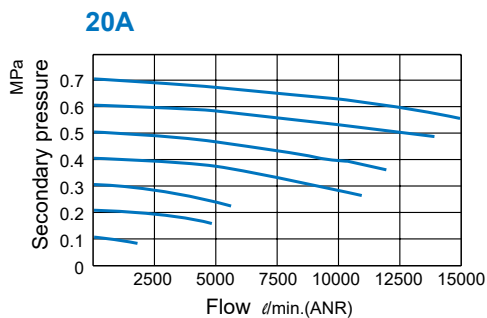

MAF501 Dimensions

AIR UNIT (FILTER)



MAF501-D

Auto drain valve

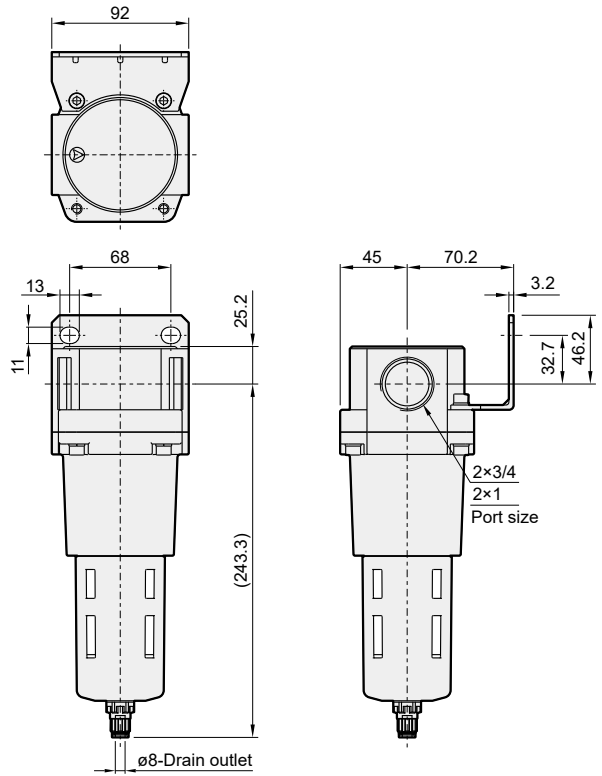
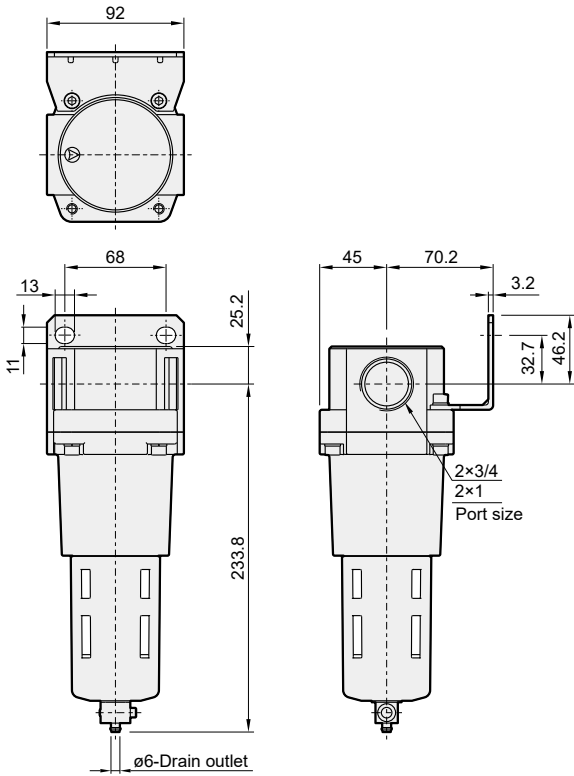

MAF501-M

Metal bowl

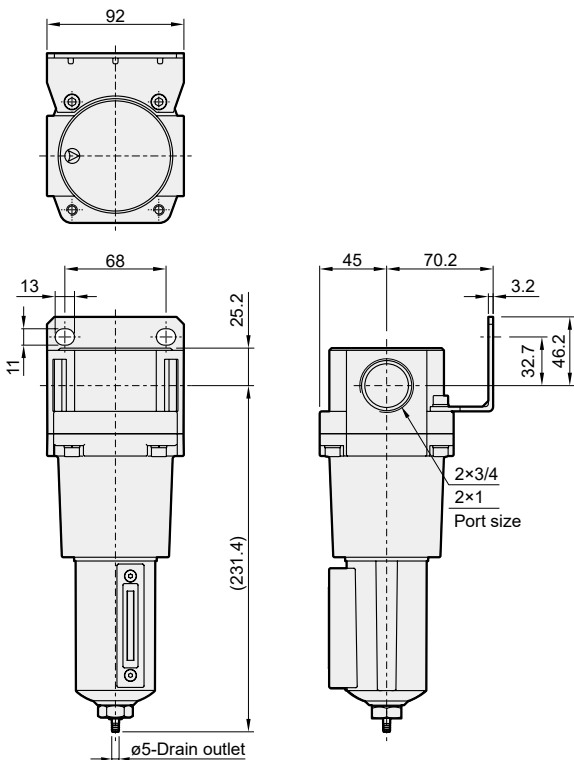

MAF501-MD

Metal bowl + auto drain valve

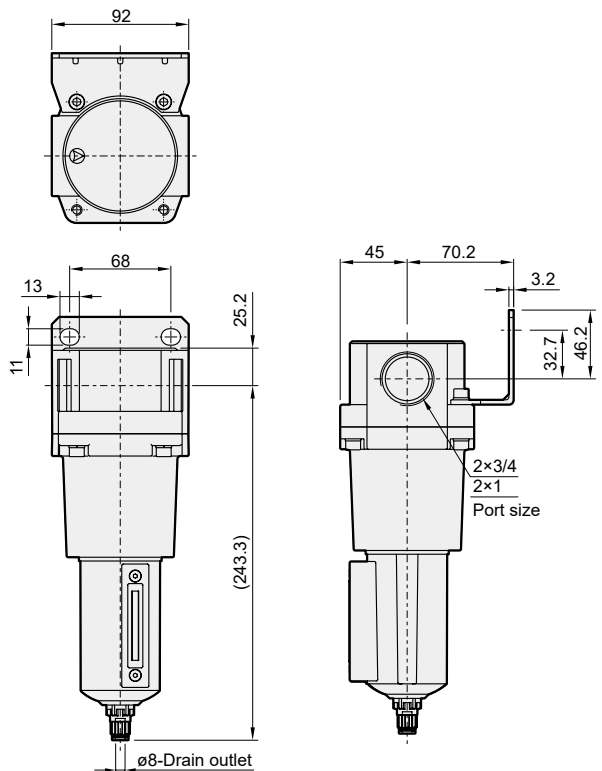

MAF900 series

AIR UNIT (FILTER)



Technical data



User manual



Caution for safety
(Read before installing)



- Removing upto 99% of the liquid water.
- Design of the filter elements gives both surface and depth filtration for cleaner air.
- Ideally suited for header lines and large flow rated tools and cylinder operations.

Symbol

Manual drain

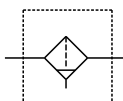

Auto drain

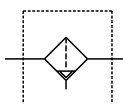

Specification

Model	MAF900
Bore No.	40A
Port size	1 1/2
Medium	Air
Operating pressure range (*1)	0.05~1.75 MPa
Ambient temperature	0~+80°C (No freezing)
Filter element	Standard: 50µm
Standard nominal flow rate (*2)	20000 ℓ /min
Weight	2035 g

*1. Choose auto-drain, the pressure range is 0.15~1 MPa.

*2. Flow is at pressure P= 0.6 MPa with pressure drop ΔP=0.1 MPa.

Order example

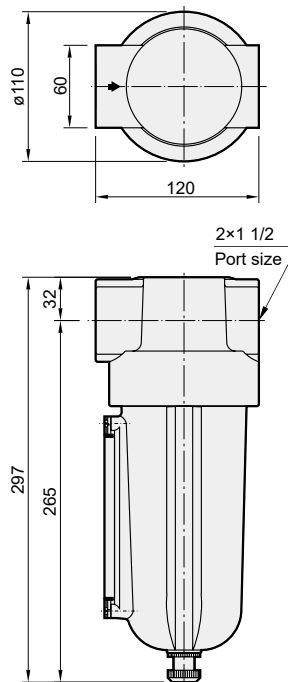
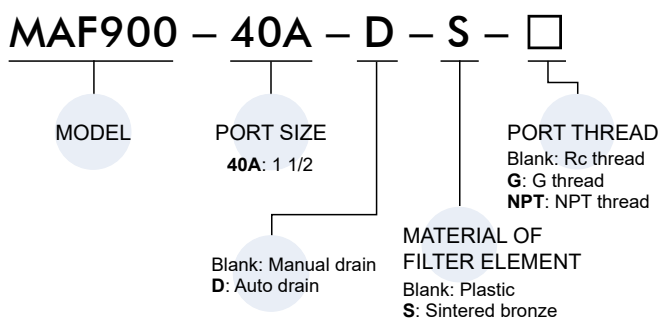

Flow feature

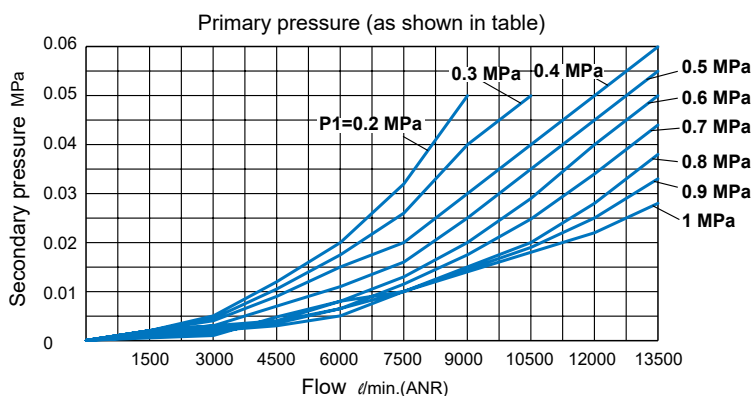

Auto drain

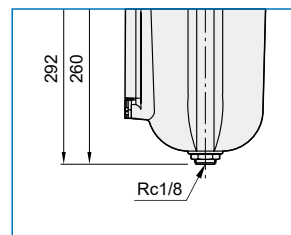

MAF901 series

AIR UNIT (FILITER)



Technical data



User manual



Caution for safety
(Read before installing)



Symbol

Manual drain

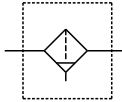

Auto drain

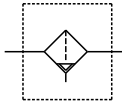

- MAF901 with high water removal efficiency and minimal pressure drop are used for removal of liquids and solid contaminants to protect air tools and equipment.
- Ideally suited for header lines and very high flow applications.

Specification

Model	MAF901
Bore No.	50A
Port size	2
Medium	Air
Operating pressure range (*1)	0.05~1.75 MPa
Ambient temperature	0~+80°C (No freezing)
Filter element	Standard: 50μm
Standard nominal flow rate (*2)	63000 ℓ /min
Weight	6930 g

*1. Choose auto-drain, the pressure range is 0.15~1 MPa.

*2. Flow is at pressure P= 0.6 MPa with pressure drop ΔP=0.1 MPa.

Order example

MAF901 – 50A – D – □

MODEL

PORT SIZE
50A: 2

PORT THREAD
Blank: Rc thread
G: G thread
NPT: NPT thread

Blank: Manual drain
D: Auto drain

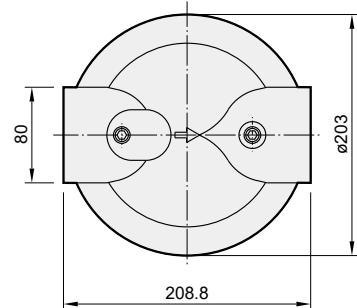

Flow feature

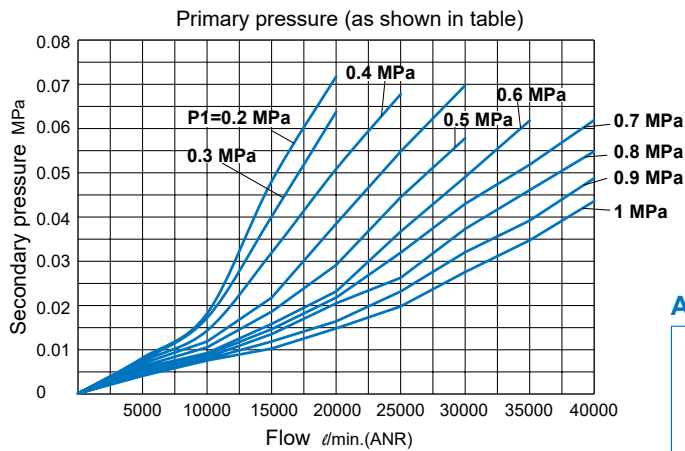

Auto drain

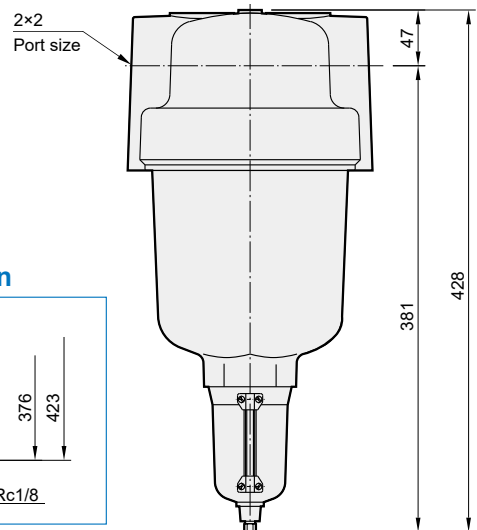
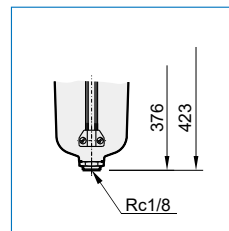

MAD400 series

AUTO DRAINER



Technical data



Auto drain valve



Caution for safety
(Read before installing)



Symbol

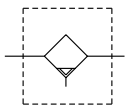

Specification

Model	MAD400		
Bore No.	8A	10A	15A
Port size	1/4	3/8	1/2
Medium	Air		
Operating pressure range (*)	0.15~1 MPa		
Proof pressure	1.5 MPa		
Ambient temperature	- 5~+60°C (No freezing)		
Weight	480 g		

* Standard unit contains semi-auto-drain function when operating pressure below 0.05 MPa.

Order example

MAD400 – 8A – D3 – □

MODEL

PORT SIZE

8A: 1/4
10A: 3/8
15A: 1/2

PORT THREAD

Blank: Rc thread
G: G thread
NPT: NPT thread

AUTO DRAIN VALVE

Blank: Male thread (MADV400-WB)
D3: Female thread (MADV400-WA)

MAD400-D3

Female thread (MADV400-WA)

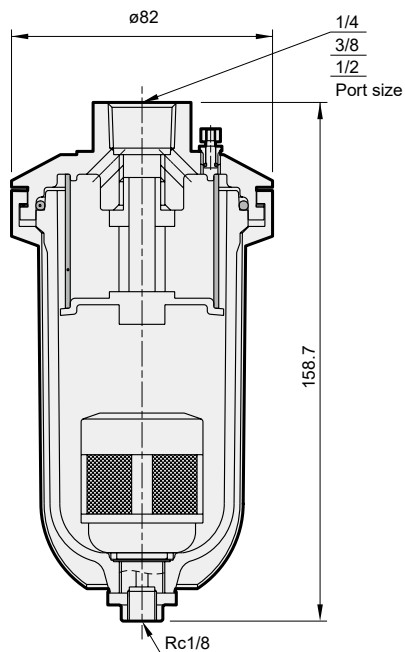

MAD400

Male thread (MADV400-WB)

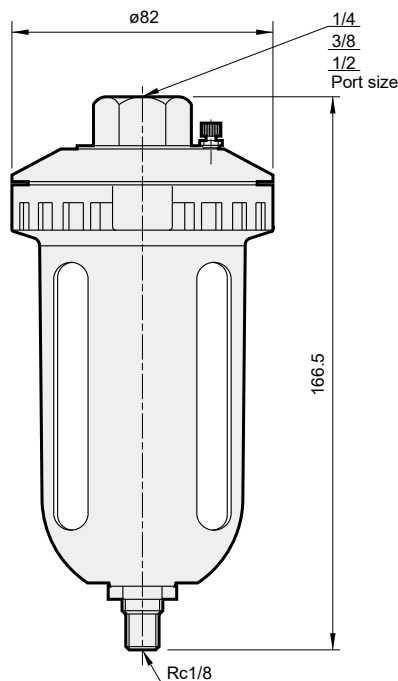

MAD401 series

AUTO DRAINER



Technical data



Caution for safety
(Read before installing)



Symbol

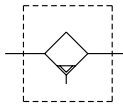

Features

- Max. operating pressure: 1.3 MPa

Specification

Model	MAD401
Bore No.	15A
Port size	1/2
Medium	Air
Operating pressure range (*)	0.1~1.3 MPa
Proof pressure	1.7 MPa
Ambient temperature	-5~+80°C (No freezing)
Weight	745 g

* Standard unit contains semi-auto-drain function when operating pressure below 0.05 MPa.

Order example

MAD401 - 15A - □

MODEL PORT SIZE PORT THREAD

15A: 1/2

Blank: Rc thread
G: G thread
NPT: NPT thread

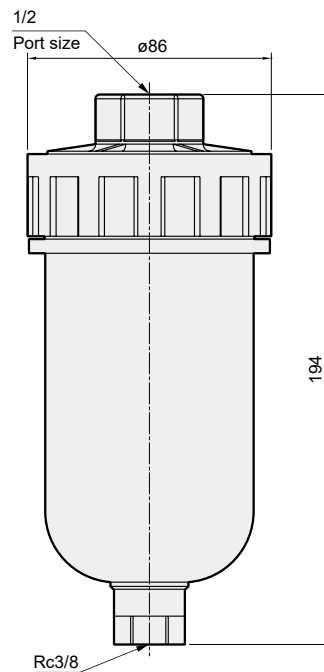

MAD401H series

AUTO DRAINER



Technical data



Caution for safety
(Read before installing)



Symbol

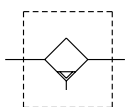

Features

- Max. operating pressure: 1.3 MPa

Specification

Model	MAD401H
Bore No.	15A
Port size	1/2
Medium	Air
Operating pressure range (*)	0.1~1.3 MPa
Proof pressure	2.0 MPa
Ambient temperature	- 5~+60°C (No freezing)
Weight	519 g

* Standard unit contains semi-auto-drain function when operating pressure below 0.05 MPa.

Order example

MAD401H - 15A - □ - □

MODEL

PORT SIZE
15A: 1/2

EXTERIOR COLOR
Blank: Black & silver
W: Gray & white

PORT THREAD
Blank: Rc thread
G: G thread
NPT: NPT thread

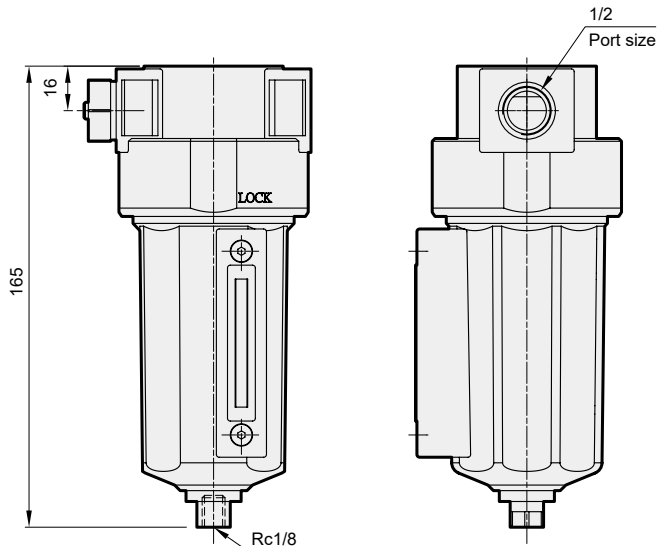
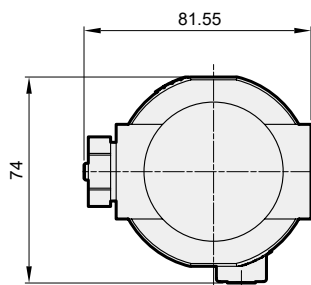



Caution for safety
(Read before installing)



Specification

Model	MAD500	MAD500M
Dimensions	High 18cm (7"), Diameter 10cm(4")	
Inlet	Rc1/2	
Outlet	Rc3/8	
Operating perssure range	0.13~1.3 MPa	
Ambient temperature	2~60°C (36~104°F)	
Weight	780 g	
Discharge per operation	60cc per on time. Max. operation 25 times per minute.	

* Standard unit contains semi-auto-drain function when operating pressure below 0.05 MPa.

Order example * Port thread G. NPT. are also available.

MAD500 – M

MODEL

FILTER BOWL
MATERIAL

Blank: Polycarbonate (PC)
M: Alumium Alloy

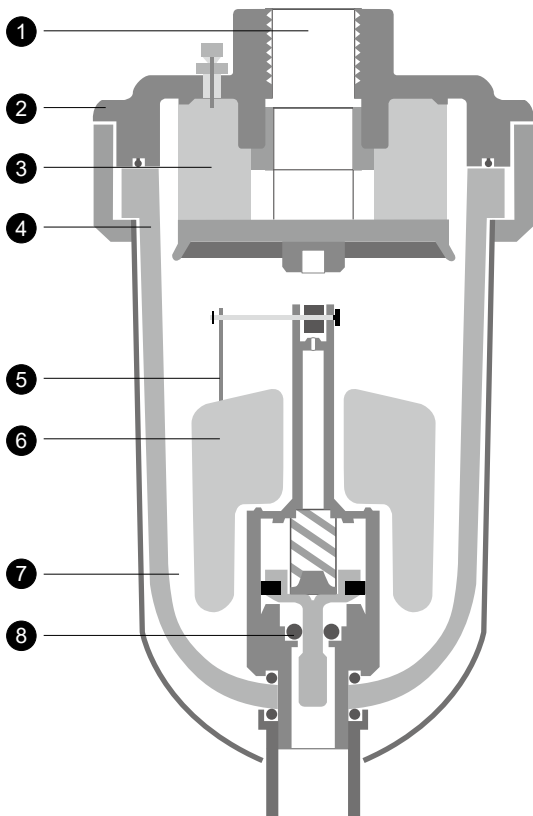

Improve the quality of compressed air

Modern plants use large quantity of compressed air to operate many precise automatic machines. With air pollution getting worse in the environment, polluted air from plants and automobiles have increase in a great deal. As the result, the quality of compressed air is degraded due to the dust, oil mist within plants and the increased temperature of the environment The addition of expensive drying equipment and precise filter can block some water and impurity. But can not block acid chemicals in polluted air such as sulfur dioxide (SO₂), tiny oil mist and dust that are smaller than 0.01micron from entering the compressed air system.

After years of accumulation, these harmful materials can reduce the efficiency and service life of the drying equipment and filter systems. Furthermore, they can corrode the compressed air pipeline and some parts to affect the operation of automatic machines. The only way to prevent these is to use the excellent compressed air automatic drain valve to drain water, oil mist, rust and acid chemicals out of the compressed air system. It will increase the quality of compressed air, smooth the machine operation and increase the production efficiency.

- ① With large diameter sized entrance and path for particles and rust to pass through, no accumulation will occur in dead corners.
- ② Aluminum alloy casting with special anti-corrosion treatment and then coated with high quality baking varnish can withstand acid and alkali without any corrosion occurring.
- ③ Large volume filtered dirt storing compartment can filter and store more rust and dirt than other common automatic drain valve.
- ④ Water collecting bowl, made of optical class transparent plastic material, will not rupture.
- ⑤ Implanted stainless rod for float will never slip off.
- ⑥ Large size float has more buoyancy and is more sensitive to control.
- ⑦ Large size water collecting bowl can store and drain more water thus reduce the draining time and increase the service life of automatic drain valve.
- ⑧ Leakage proof ring, made of high quality VITON rubber, can endure abrasion without leakage. Its service time is ten times longer than NBR rubber.

MAD501 series

AUTO DRAINER



Caution for safety
(Read before installing)



- Clean compressed air, extends the life of pneumatic equipment.
- No electricity required.
- Easy installation not limited by space.

Specification

Model	MAD501	MAD501H
Inlet	Rc1/2	
Manual outlet	Rc1/2	
Automatic outlet	Rc3/8, 5/16"HOSE	
Operating pressure range	0.13~0.88 MPa	0.3~1.27 MPa
Ambient temperature	+2~+60°C	
Min. equipment requirement	180 l/min (about 1 HP)	250 l/min (about 2 HP)
Max. condensate discharge rate	15 gal/hour (57 l/h)	12 gal/hour (46 l/h)
Bowl	Polycarbonate (PC)	Aluminium
Dimensions	160mm×100mm×200mm	
Weight	1.3 kg	1.4 kg

* Standard unit contains semi-auto-drain function when operating pressure below 0.05 MPa.

Order example * Port thread G. NPT. are also available.

MAD501 – H

MODEL

FILTER BOWL MATERIAL

Blank: Polycarbonate (PC)
H: Aluminium Alloy

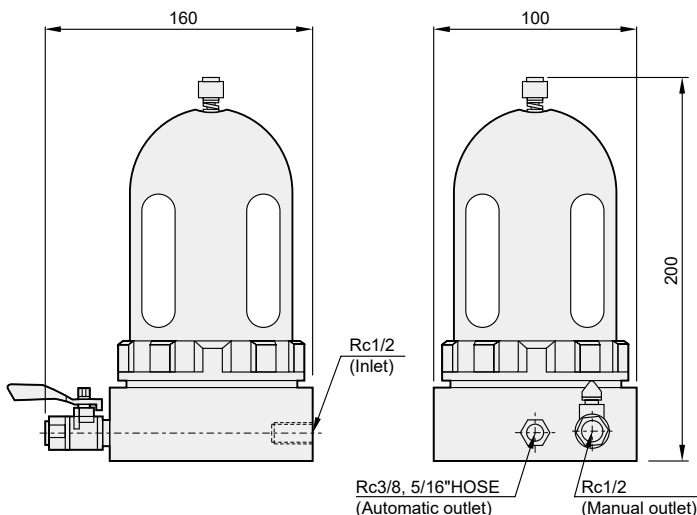

Continuous elimination of water

MAD501(H) automatic drain valve features an advanced design. Through the hose connections, Condensate, oil and sludge are eliminated from the compressed air equipment. The continuous-duty drainer constantly collects contaminants until these are eliminated "on demand" thus keeping a compressed air system clean. When installing the drainer, one is not limited by height nor position; uniquely, it can be installed in any ideal place or position. Since it needs only air pressure to operate, no electrical or outside controlling mechanisms are required. It rapidly and accurately eliminates water and other contaminants.

Solid, liquid and gas separation

The specially designed structure of the **MAD501(H)** separates solid, liquid and air. Since the controlling mechanisms are located in the air section, the moving parts are not affected by water, oil, or sludge-producing years of trouble-free draining.

An integral part of the MAD501(H)'s design is the large cylindrical filter and manual valve (located in the base). Here, solids such as rust and pipe scale collect. In order to eliminate this waste, one need not stop the unit or use any tools; conversely, by briefly opening the manual valve, waste is immediately purged from the unit.

Finally, the liquid water and oil collect in the lower chamber (away from the controlling mechanisms) until purged either automatically or by opening the manual valve.

Applications

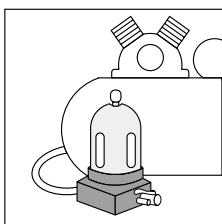

Air compressor

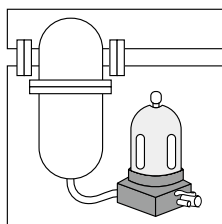

Separator

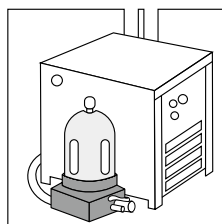

Air dryer

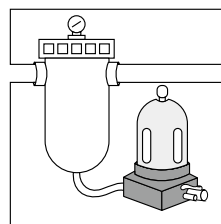

Air filter

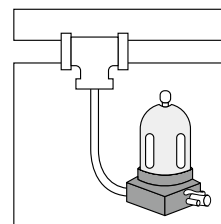

Drop leg

FMRF300 / MADV400 series

AUTO DRAIN VALVE

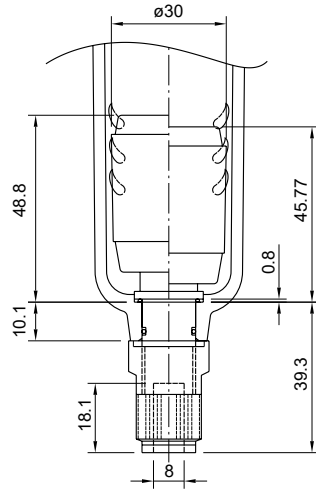

Specification

Model	FMRF300
Operating pressure range	0.15~1 MPa
Proof pressure	1.5 MPa
Ambient temperature	- 5~+60°C (No freezing)

Order example

FMRF300 – AD – U

for AIR UNIT
 MA**302 series
 MA**400 series
 MA**401 / 403 series
 MA**501 series
 * Ordered with filter together.



Specification

Model	MADV400
Operating pressure range	0.05~1.3 MPa
Proof pressure	2.0 MPa
Ambient temperature	- 5~+60°C (No freezing)

Order example

MADV400 – WB

MODEL

TYPE
 WA
 WB

WA

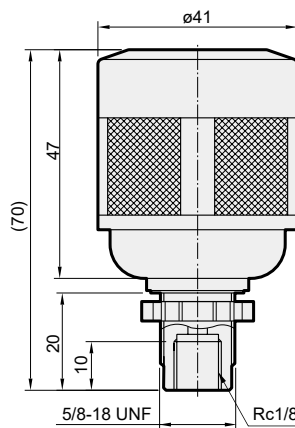

WB

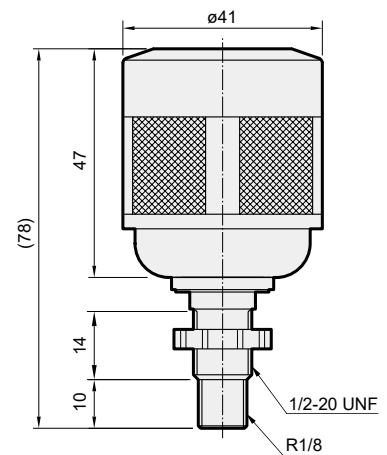

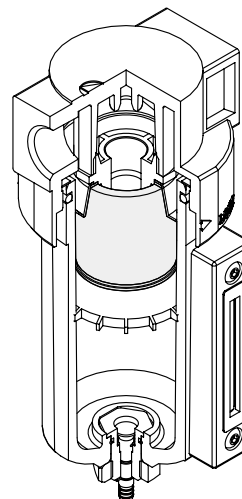

Order example

E40 – 200

FILTER
ELEMENT

SERIES

The table of the symbol

Applicable model						Symbol for order		
series	MACT	MACP	MAFR	MAF	MAFV	E5: 5μ	E20: 20μ	E40: 40μ
100			●			E5-100	–	E40-100
200	●	●	●	●		E5-200	–	E40-200
302	●	●	●	●		E5-302	–	E40-302
					●	E5-302V	–	–
400		●	●			E5-R400	–	E40-R400
400	●			●		E5-400	–	E40-400
401	●	●	●	●		E5-401	–	E40-401
403	●	●	●	●		E5-401	–	E40-401
501	●			●		–	–	E40-501
501		●	●			–	–	E40-R501

EX: If order the 5u element of MACT302, the order symbol is E5-302.

Applicable model	Symbol for order		
	E001: 0.01μ	E03: 0.3μ	E5: 5μ
MAF200(L)D	–	E03-200	–
MAF200(L)M	E001-200	–	–
MAF302D, MAF401D, MAF403D	–	E03-302	–
MAF302M, MAF401M, MAF403M	E001-302	–	–
MAFF401AD, MAFRF401	–	E03-302	E5-401
MAFF401DM	E001-302	E03-302	–
MATFR401	E001-302	E03-302	E5-401
MAF403A	–	–	E5-401
MAF501D	–	E03-501	–
MAF501M	E001-501	–	–

MAR100 series

PRESSURE REGULATOR



Technical data



User manual



Caution for safety
(Read before installing)



Symbol

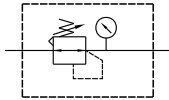

Specification

Model	MAR100
Port size	M5×0.8
Medium	Air
Max. operating pressure	1 MPa
Proof pressure	1.5 MPa
Regulated pressure range	0.05~0.7 MPa
Repeatability	±10% F.S.
Ambient temperature	-5~+60°C (No freezing)
Flow rate (*)	90 ℓ/min
Attachment	Pressure gauge (PG-25), bracket
Weight	100g

* Measured at primary pressure 0.7 MPa, secondary pressure 0.6 MPa and pressure drop 0.1 MPa.

Order example

MAR100 — M5 — B — C □

MODEL

PORT SIZE

BRACKET

Blank: without
B: with bracket

PRESSURE GAUGE

Blank: without
C: with gauge

FLOW DIRECTION

Blank: Left to right
R: Right to left

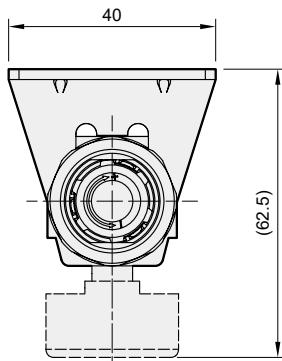

Panel mounting hole

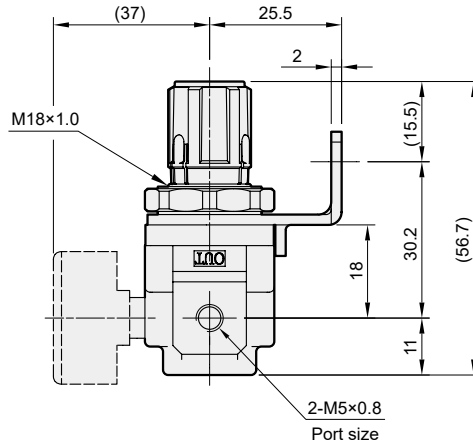
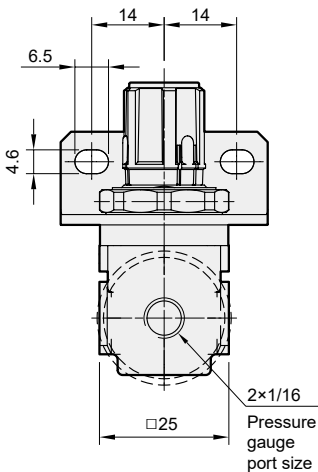
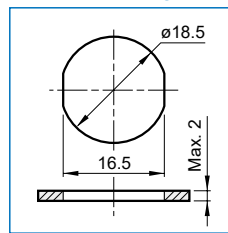

Pressure characteristics

Supply pressure: 0.7 MPa
Secondary pressure: 0.2 MPa
Flow: 20 ℓ/min.(ANR)

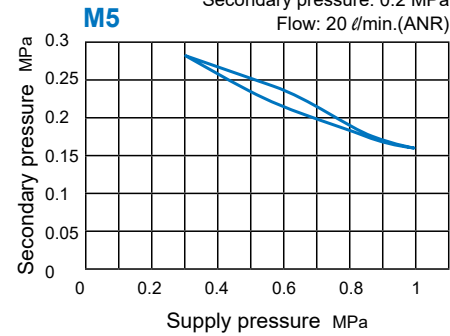

Flow feature

Primary pressure 0.7 MPa

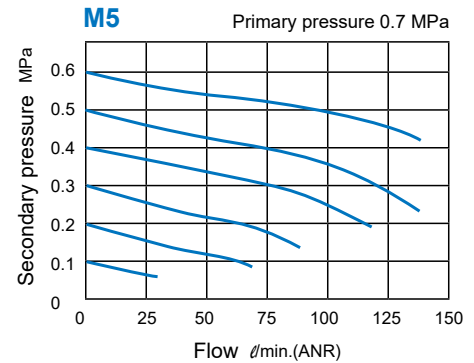

for MAFR302 / 401 / 403

for MAR200 / 201 / 302 / 401 / 403

Installation direction

When choosing the flow direction, the backflow module can not be exchanged with gauge. If you have special order request, please contact our sales department.

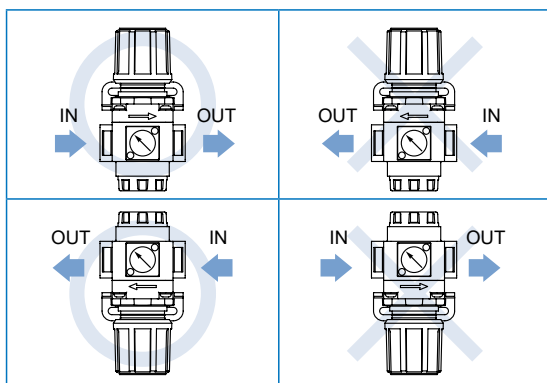

Precautions

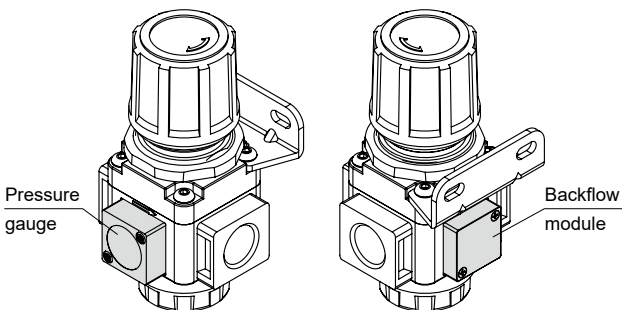

- When the air supply is cut off, the inlet pressure less than outlet pressure, the residual pressure return to the inlet side.
- Please set the inlet pressure to at least 0.05MPa higher than the set pressure.

Working principle of backflow function

Normally, as the inlet pressure (IN) is higher than the setting pressure (pressure of outlet), the backflow valve is closed. If the inlet pressure is cut off, backflow valve will be open and the outlet pressure is exhausted to IN port.

Normal air supply

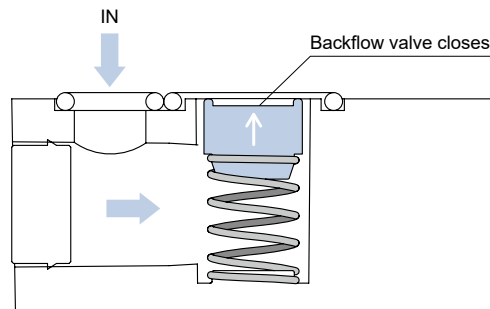

Cut off air source

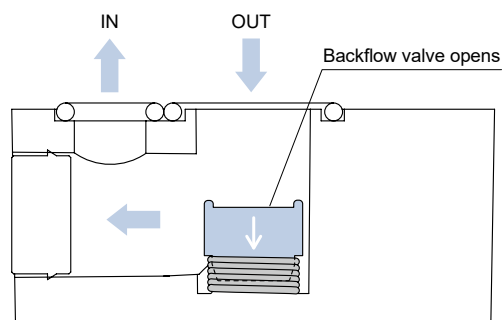

MAR200 series

PRESSURE REGULATOR



Technical data



User manual



Caution for safety
(Read before installing)



Symbol

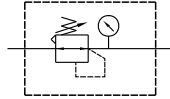

Standard

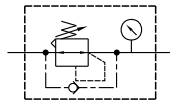

Backflow

Specification

Model	MAR200	
Bore No.	6A	8A
Port size	1/8	1/4
Medium	Air	
Max. operating pressure	1 MPa	
Proof pressure	1.5 MPa	
Regulated pressure range	Standard type: 0.05~0.85 MPa	
Ambient temperature	- 5~+60°C (No freezing)	
Attachment	L type bracket	
Option	Pressure gauge (PG-40), Z-type bracket	
Weight	190 g	

Order example

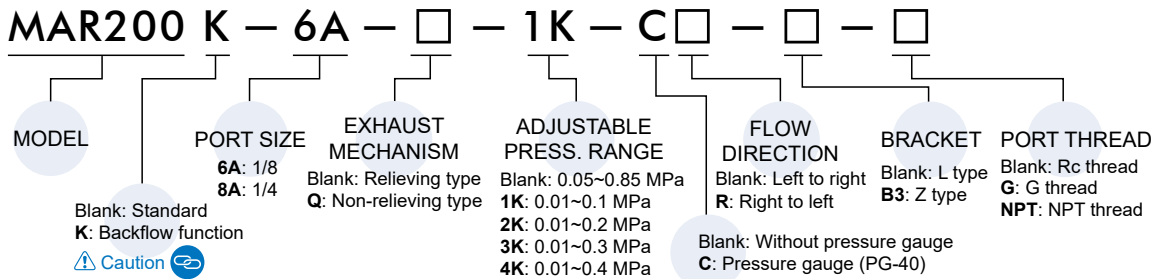

* Standard type regulator can not release the outlet pressure completely, even if inlet pressure was cut off, and the backflow function (K) must be applied to completely remove the residual pressure.

* The (Q) non-relieving type regulator is used. When the output pressure is higher than the set pressure, the output pressure will not flow out through the exhaust hole.

Flow feature

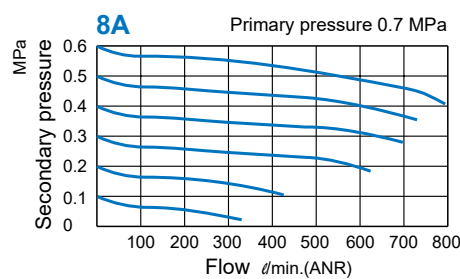
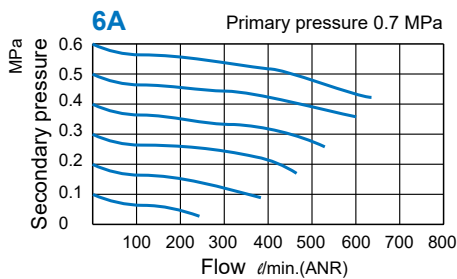

MAR200 Dimensions

PRESSURE REGULATOR



Solenoid Valve

Process Valve

Pilot & Mechanical Valve

Air Treatment Unit

Pressure Switch

Compressed Air Dryer

Auxiliary Equipment

PISCO®

PLC Control System

MAR200

L type bracket

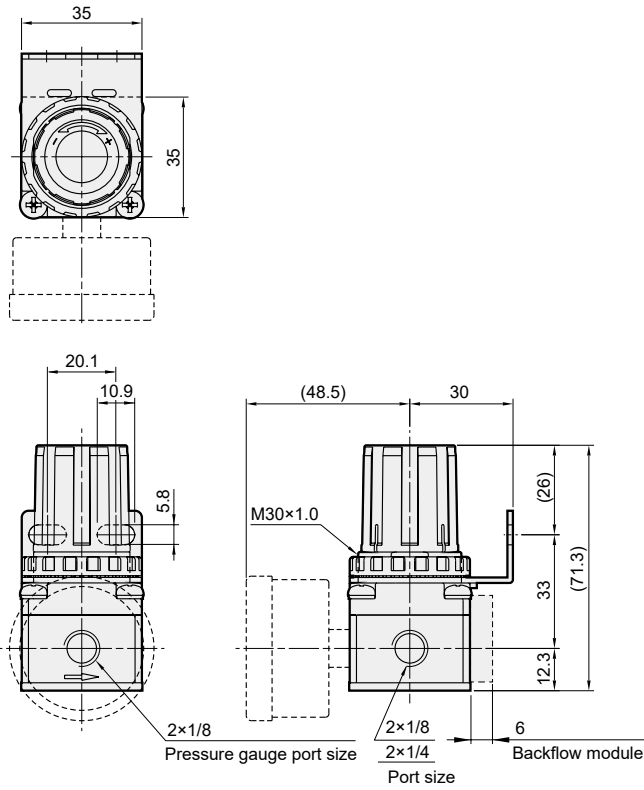

MAR200-B3

Z type bracket

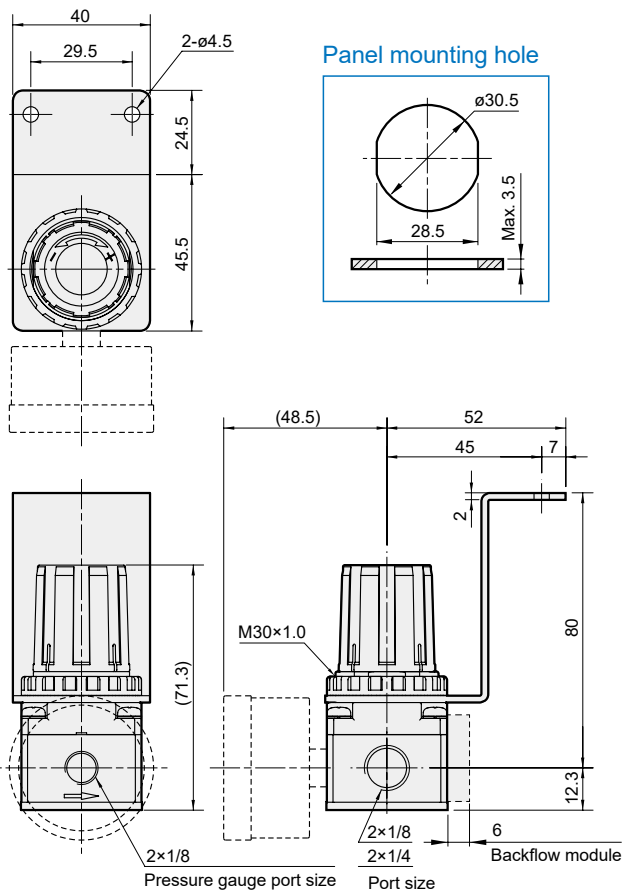

MAR302 series

PRESSURE REGULATOR



Technical data



User manual



Caution for safety
(Read before installing)



Option: **MP41**

Symbol

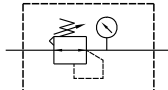

Standard

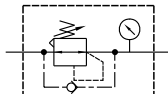

Backflow

Specification

Model	MAR302		
Bore No.	8A	10A	15A
Port size	1/4	3/8	1/2
Medium	Air		
Max. operating pressure	1 MPa		
Proof pressure	1.5 MPa		
Regulated pressure range	0.05~0.85 MPa		
Ambient temperature	- 5~+60°C (No freezing)		
Attachment	Pressure gauge (PG-20), L type bracket		
Weight	400 g		

Order example

MAR302 K - 8A - [] - [] [] - E1 - [] - []

MODEL

Blank: Standard
K: Backflow function
 ⚠ Caution ⚙

EXHAUST MECHANISM

Blank: Relieving type
Q: Non-relieving type

FLOW DIRECTION

Blank: Left to right
R: Right to left

BRACKET

Blank: L type
B3: Z type

PORT THREAD

Blank: Rc thread
G: G thread
NPT: NPT thread

PORT SIZE

8A: 1/4
10A: 3/8
15A: 1/2

PRESSURE GAUGE

Blank: Standard type (PG-20)
C: External pressure gauge (PG-40) +
 Gauge adapter set (A-MAR302)
A: Gauge adapter set (A-MAR302)

PRESSURE SWITCH

Blank: without
E1: MP41P-022
E2: MP41P-022-QD**
E5: MP41P-042
E6: MP41P-042-QD**

** MOQ required. Please contact us.

* Standard type regulator can not release the outlet pressure completely, even if inlet pressure was cut off, and the backflow function (K) must be applied to completely remove the residual pressure.

* The (Q) non-relieving type regulator is used. When the output pressure is higher than the set pressure, the output pressure will not flow out through the exhaust hole.

* PG-40 (C), A-MAR302 (A) and MP41 (E*) can not be selected at the same time.

* Refer to digital pressure switch MP41 (E*).

Flow feature

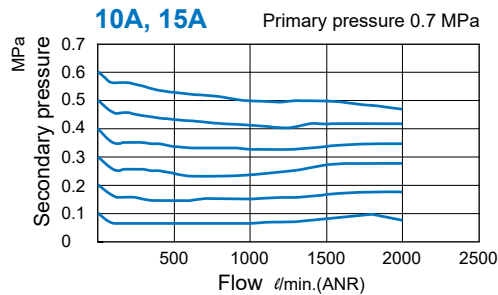
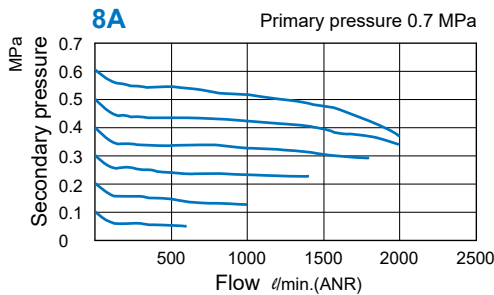

MAR302 Dimensions

PRESSURE REGULATOR



MAR302

L type bracket

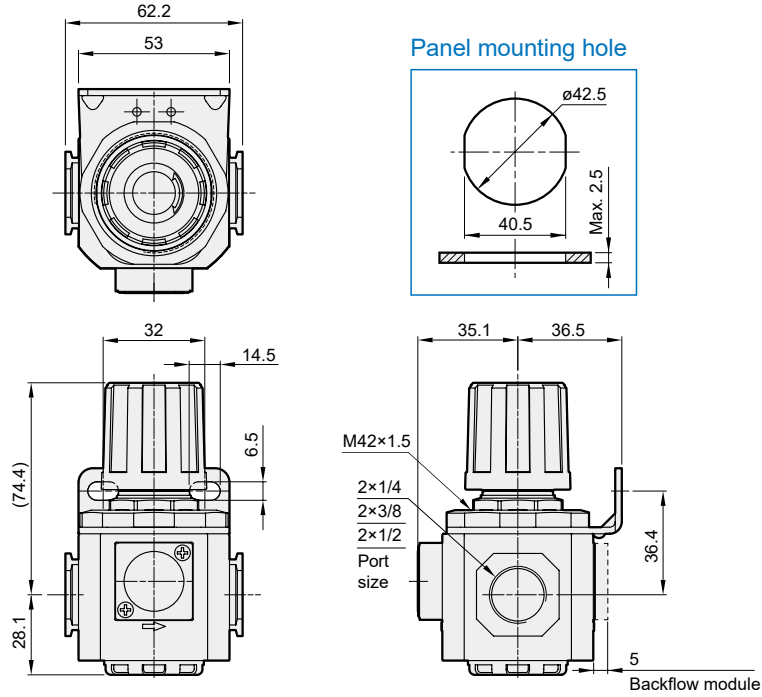

MAR302-B3

Z type bracket

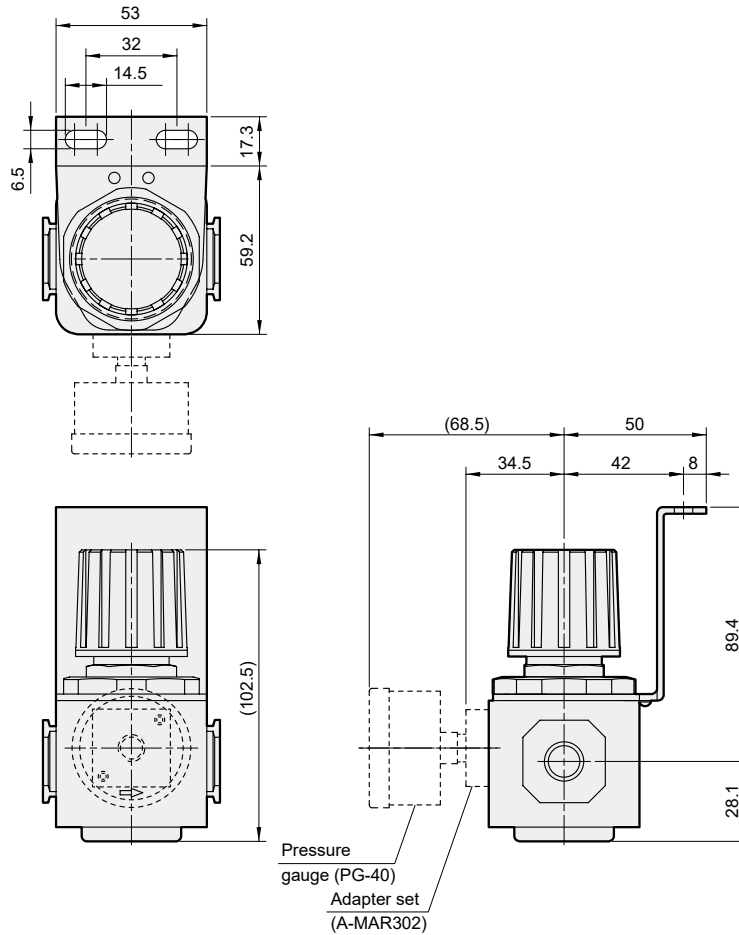

MARV302 series

VACUUM PRESSURE REGULATOR



Technical data



Caution for safety
(Read before installing)



Option: MP48E

Symbol

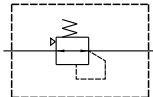

Feature

- Installed after vacuum pump and used to adjust the vacuum pressure for operational requirements of the machine.
- Can be assembled with MAFV302 to achieve modular design.
- High flow rate up to 310 ℓ/min (ANR).
- Accurate vacuum control (resolution within 0.13 kPa) and high stability.

Specification

Model	MARV302		
Bore No.	8A	10A	15A
Port size	1/4	3/8	1/2
Medium	Air		
Proof pressure (*1)	100 kPa		
Setting pressure range (*2)	-100 ~ -1.3 kPa		
Atmospheric intake consumption (*3)	0.6 ℓ/min (ANR) or less		
Knob resolution	0.13 kPa or less		
Ambient temperature	-5~+60°C (No freezing)		
Max. flow rate (*4) ℓ/min (ANR)	275	310	
Option	Pressure gauge (PGV-40S), L type bracket		
Weight	470 g		

Order example

MARV302 – 8A – C – □ – □

MODEL PORT SIZE BRACKET PORT THREAD

8A: 1/4
10A: 3/8
15A: 1/2

Blank: without
B: L type

Blank: Rc thread
G: G thread
NPT: NPT thread

PRESSURE GAUGE

- Blank: without gauge
- C: Pressure gauge (PGV-40S)
- E5: Digital pressure switch (MP48E-010)
- E6: Digital pressure switch (MP48E-011)
- E7: Digital pressure switch (MP48E-02R)

* For piping ports with NPT threads, please contact us if digital pressure sensor (E*) is required.

*1. For vacuum regulator with pressure gauge, the gauge will be damaged if positive pressure is supplied.

*2. Use caution it varies depending on the pressure in vacuum pump side.

*3. Take air from atmosphere all the time.

*4. It is the flow rate when the secondary side is completely close and primary pressure is at -101kPa, and then adjusting secondary pressure at -80kPa, the secondary side is fully opened.

Flow feature

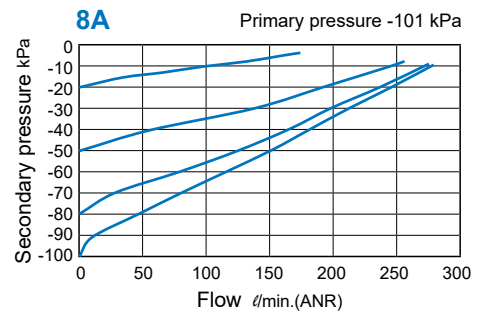

Pressure feature

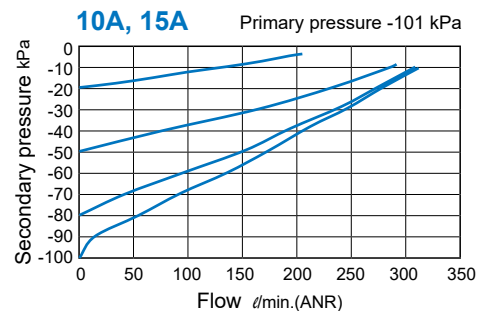
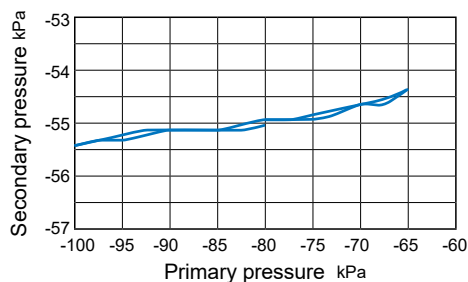

MARV302 Dimensions

VACUUM PRESSURE REGULATOR



MARV302

PGV-40S pressure gauge + L type bracket

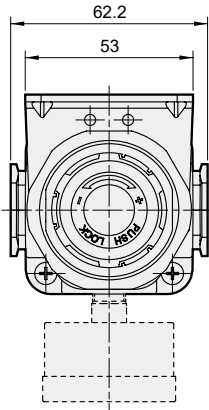

Panel mounting hole

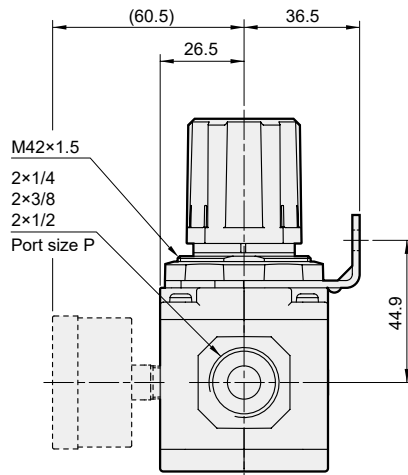
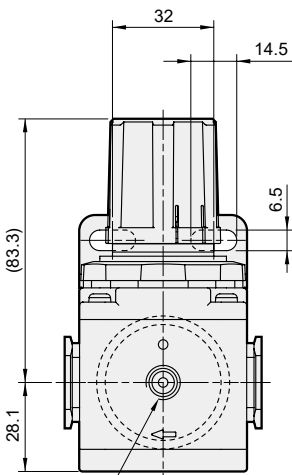
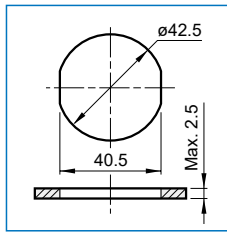

M42x1.5
2x1/4
2x3/8
2x1/2
Port size P

1/8
Gauge port size A

P Port thread	A Gauge port thread
Rc	Rc
G	Rc
NPT	NPT

MARV302-E*

MP48E digital pressure switch

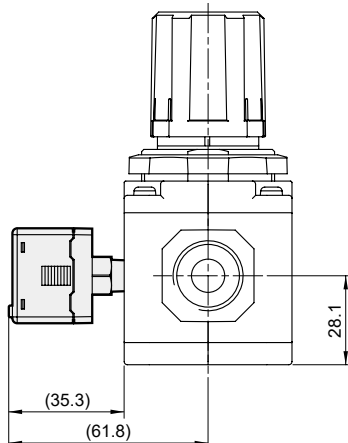
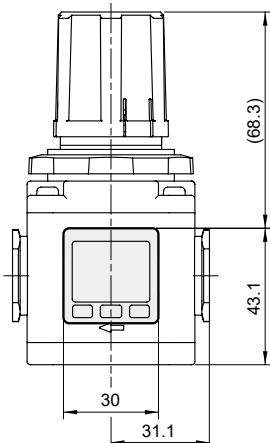

MAR400 series

PRESSURE REGULATOR



Technical data



User manual



Caution for safety
(Read before installing)



Symbol

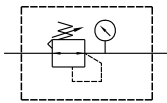

Specification

Model	MAR400		
Bore No.	8A	10A	15A
Port size	1/4	3/8	1/2
Medium	Air		
Max. operating pressure	1 MPa		
Proof pressure	1.5 MPa		
Regulated pressure range	0.05~0.85 MPa		
Ambient temperature	- 5~+60°C (No freezing)		
Attachment	Pressure gauge (PG-50), bracket		
Weight	1000 g		

Order example

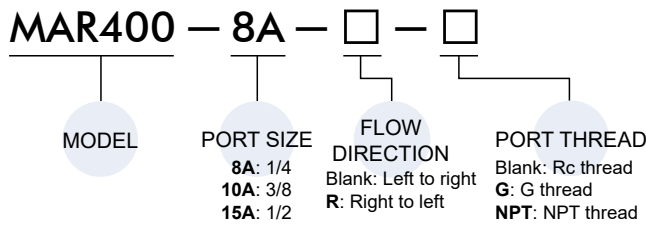

Flow feature

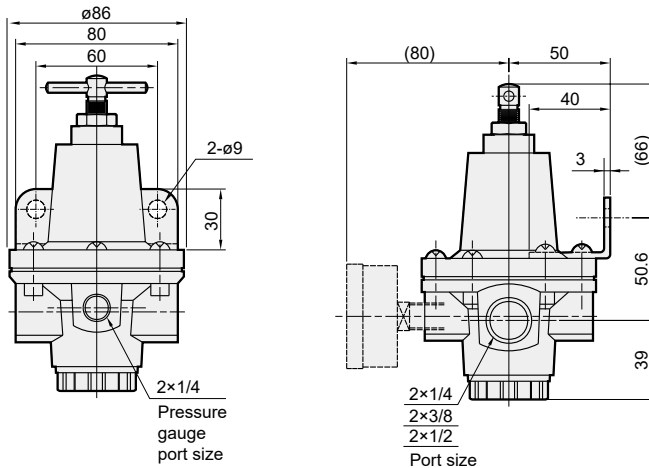
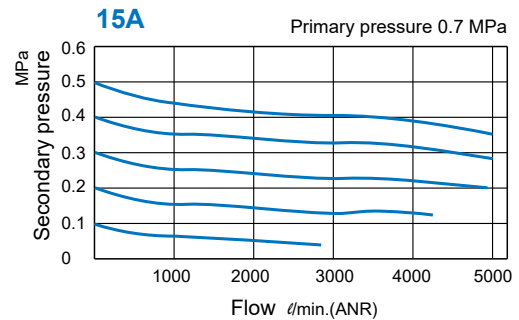
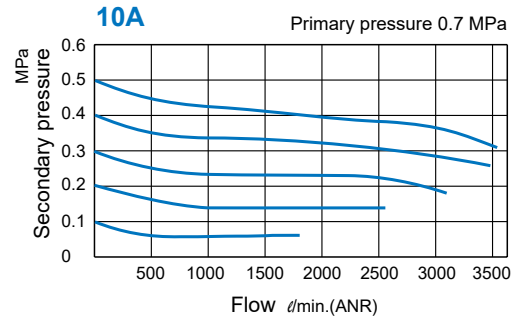
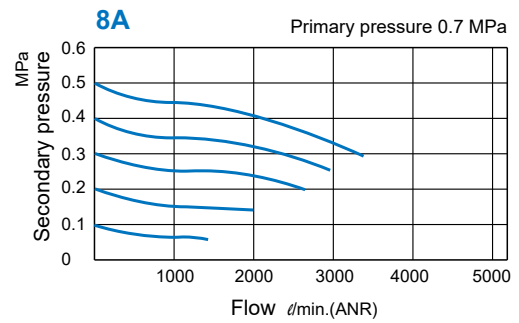

MAR401 series

PRESSURE REGULATOR



Technical data



User manual



Caution for safety
(Read before installing)



Option: **MP41**

Symbol

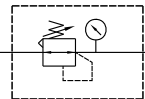

Standard

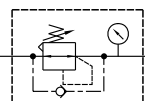

Backflow

Specification

Model	MAR401		
Bore No.	8A	10A	15A
Port size	1/4	3/8	1/2
Medium	Air		
Max. operating pressure	1.5 MPa		
Proof pressure	2 MPa		
Regulated pressure range	Standard type: 0.1~0.85 MPa		
	High pressure type: 0.1~1.5 MPa		
Ambient temperature	- 5~+60°C (No freezing)		
Attachment	Pressure gauge (PG-20)		
Weight	450 g		

Order example

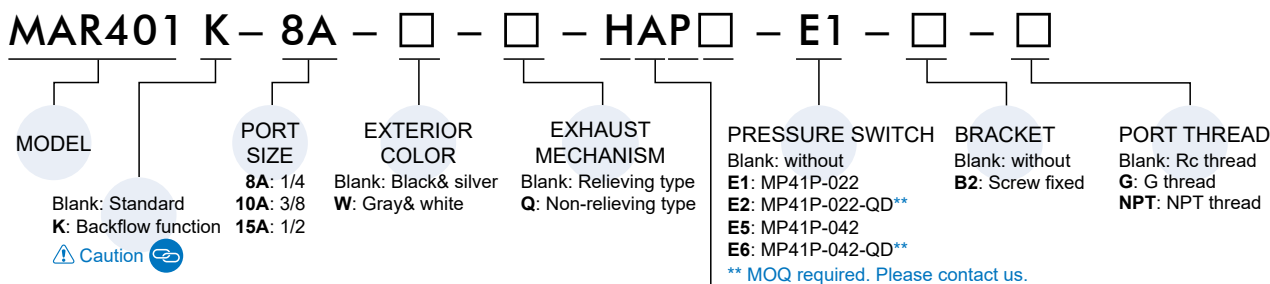

Type	Pressure gauge	Pressure switch	Flow direction
Blank: Standard type	Blank: Pressure gauge (PG-20) C : External pressure gauge (PG-40) + Gauge adapter set (A-MAR401) A : Gauge adapter set (A-MAR401)	Blank: without P : Pressure switch (MPS series)	Blank: Left to right R : Right to left
H : High pressure type	C : External pressure gauge (PG-40) + Gauge adapter set (A-MAR401) A : Gauge adapter set (A-MAR401)	-	

- * PG-40 (C), A-MAR302 (A) and MP41 (E*) can not be selected at the same time.
- * Specification (W) gauge adapter set (A-MAR302).
- * There is no pressure gauge in option (A). Please purchase if necessary.
- * Standard type regulator can not release the outlet pressure completely, even if inlet pressure was cut off, and the backflow function (K) must be applied to completely remove the residual pressure.
- * The (Q) non-relieving type regulator is used. When the output pressure is higher than the set pressure, the output pressure will not flow out through the exhaust hole.

Flow feature

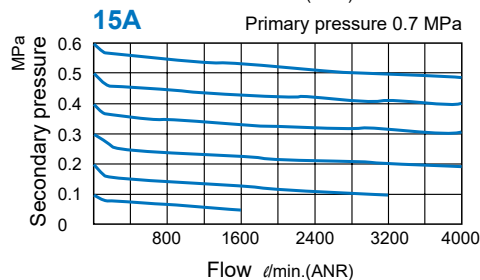
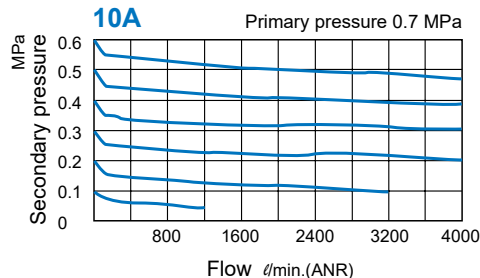
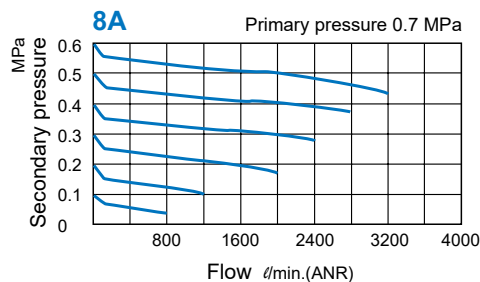

MAR401 Dimensions

PRESSURE REGULATOR



Panel mounting hole

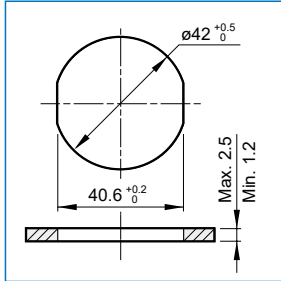

Accessories

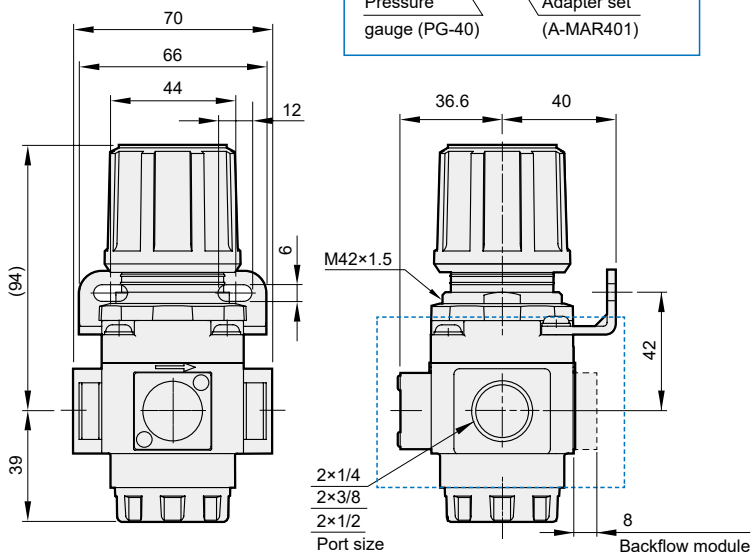
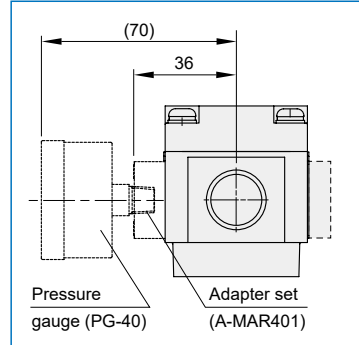

MAR401-P

MPS Series
pneumatic pressure switch

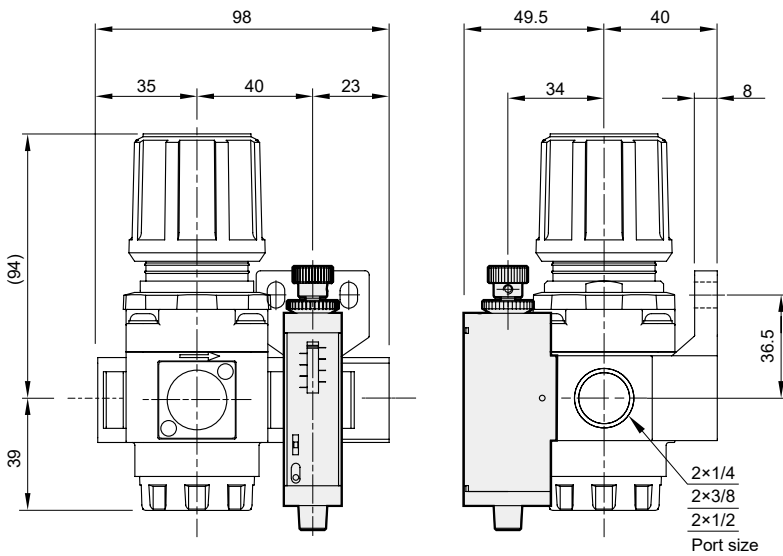

MAR403 series

PRESSURE REGULATOR



Technical data



User manual



Caution for safety
(Read before installing)



Option: MP41

Symbol

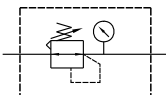

Standard

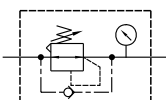

Backflow

Specification

Model	MAR403		
Bore No.	8A	10A	15A
Port size	1/4	3/8	1/2
Medium	Air		
Max. operating pressure	1 MPa		
Proof pressure	1.5 MPa		
Regulated pressure range	0.1~0.85 MPa		
Ambient temperature	- 5~+60°C (No freezing)		
Attachment	Pressure gauge (PG-20)		
Weight	450 g		

Order example

MAR403 K - 8A - [] - [] [] [] - E1 - [] - []

- MODEL**: Blank: Standard; **K**: Backflow function (Caution)
- PORT SIZE**: **8A**: 1/4; **10A**: 3/8; **15A**: 1/2
- EXHAUST MECHANISM**: Blank: Relieving type; **Q**: Non-relieving type
- PRESSURE SWITCH**: Blank: without; **E1**: MP41P-022; **E2**: MP41P-022-QD**; **E5**: MP41P-042; **E6**: MP41P-042-QD**
- BRACKET**: Blank: without; **B2**: Screw fixed
- PORT THREAD**: Blank: Rc thread; **G**: G thread; **NPT**: NPT thread

** MOQ required. Please contact us.

Pressure gauge	Pressure switch	Flow direction
Blank: Pressure gauge (PG-20) C : External pressure gauge (PG-40) + Gauge adapter set (A-MAR302) A : Gauge adapter set (A-MAR302)	Blank: without P : Pressure switch (MPS series)	Blank: Left to right R : Right to left

- * There is no pressure gauge in option (A). Please purchase if necessary.
- * PG-40 (C), A-MAR302 (A) and MP41 (E*) can not be selected at the same time.
- * Standard type regulator can not release the outlet pressure completely, even if inlet pressure was cut off, and the backflow function (K) must be applied to completely remove the residual pressure.
- * The (Q) non-relieving type regulator is used. When the output pressure is higher than the set pressure, the output pressure will not flow out through the exhaust hole.

Flow feature

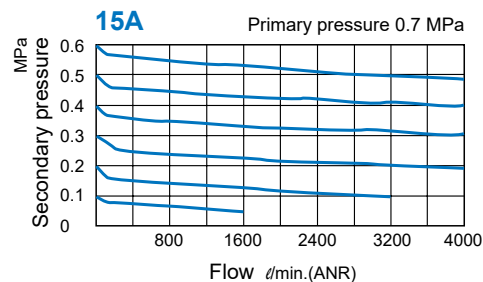
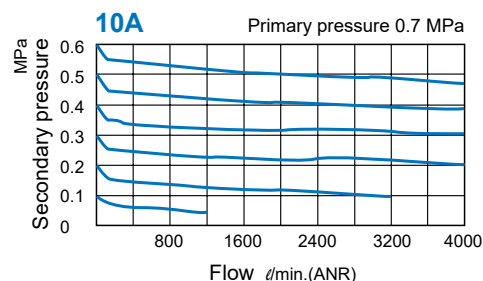
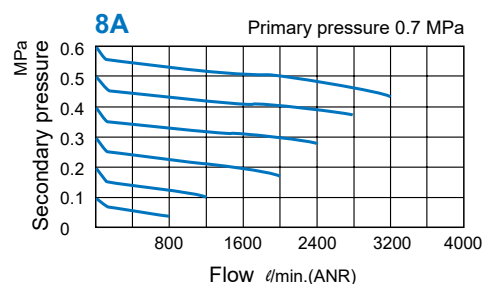

MAR403 Dimensions

PRESSURE REGULATOR

Panel mounting hole

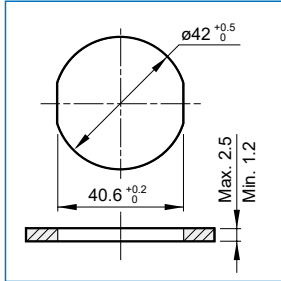

Accessories

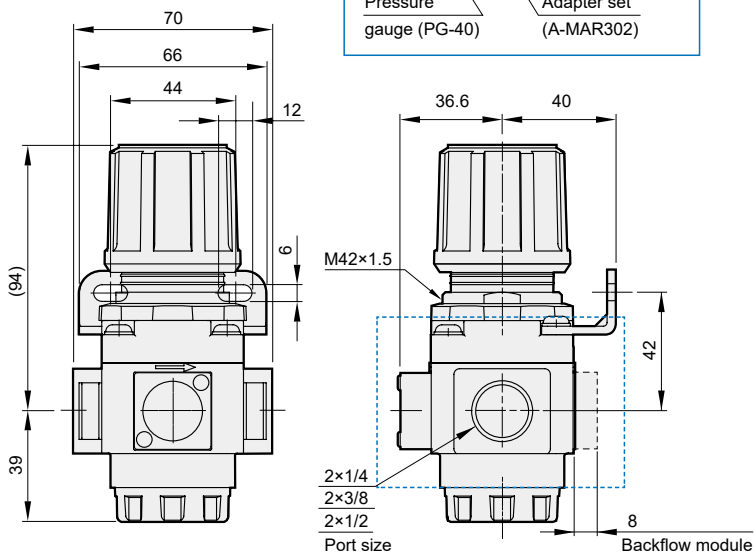
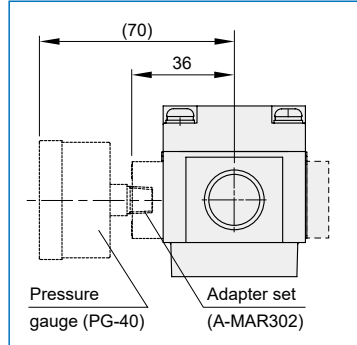

MAR403-P

MPS Series
pneumatic pressure switch

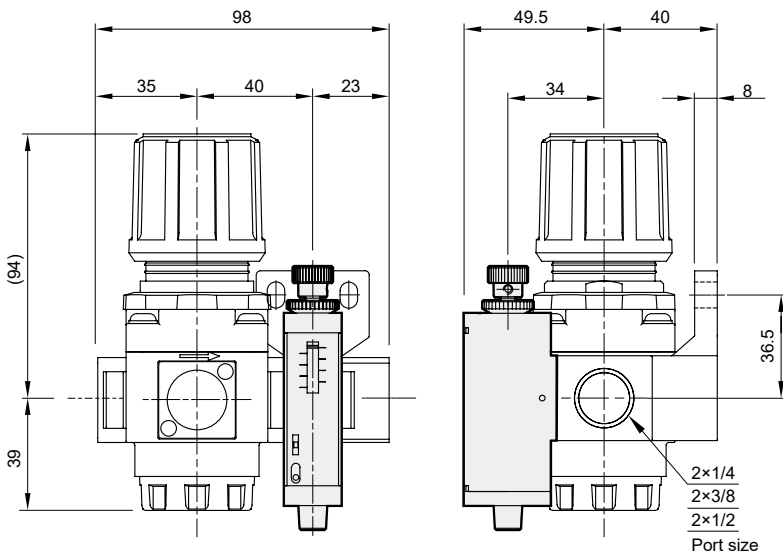

MAR501 series

PRESSURE REGULATOR



Technical data



User manual



Caution for safety
(Read before installing)



Option: **MP41**

Symbol

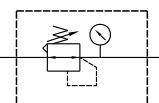

Specification

Model	MAR501	
Bore No.	20A	25A
Port size	3/4	1
Medium	Air	
Max. operating pressure	1.5 MPa	
Proof pressure	2 MPa	
Regulated pressure range	0.05~0.85 MPa	
Repeatability	±7% F.S.	
Ambient temperature	- 5~+60°C (No freezing)	
Attachment	Pressure gauge(PG-20),L-type bracket	
Weight	1460 g	

Order example

MAR501 - 20A - □□□ - E1 - □

MODEL

PORT SIZE

20A: 3/4
25A: 1

PRESSURE SWITCH

Blank: without
E1: MP41P-022
E2: MP41P-022-QD**
E5: MP41P-042
E6: MP41P-042-QD**

** MOQ required. Please contact us.

PORT THREAD

Blank: Rc thread
G: G thread
NPT: NPT thread

Pressure gauge	Panel nuts	Flow direction
Blank: Pressure gauge (PG-20) C: External pressure gauge (PG-40) + Gauge adapter set (A-MAR302) A: Gauge adapter set (A-MAR302)	Blank: without J: Panel nuts	Blank: Left to right R: Right to left

* PG-40 (C), A-MAR302 (A) and MP41 (E*) can not be selected at the same time.

* Refer to the option of digital pressure switch MP41 (E*).

Pressure characteristics

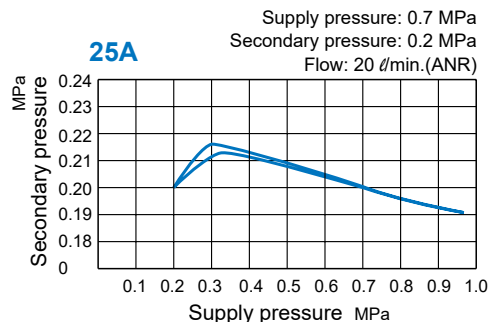
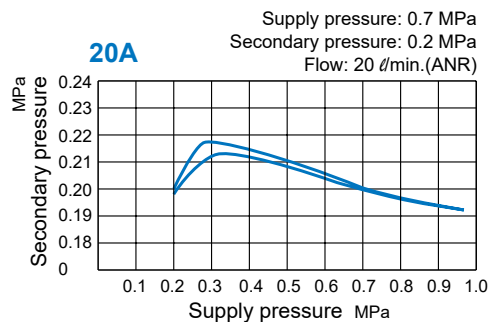

Flow feature

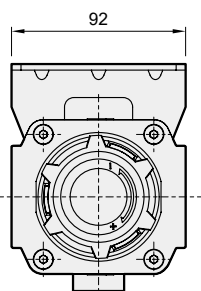
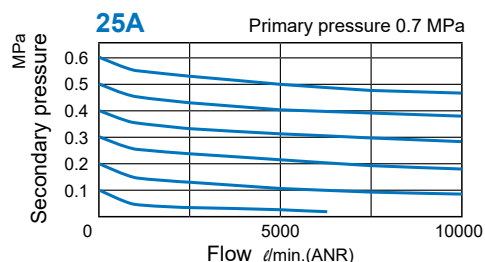
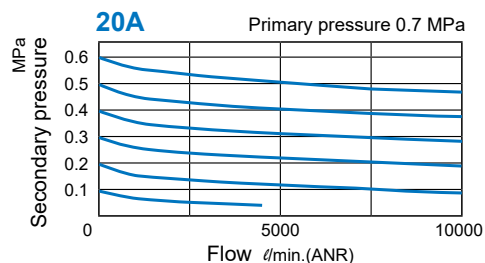

Accessories

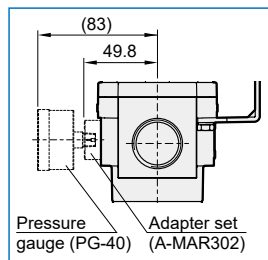

Panel mounting hole

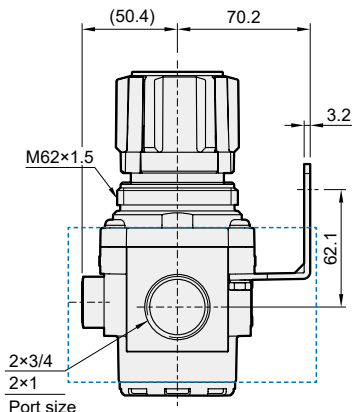
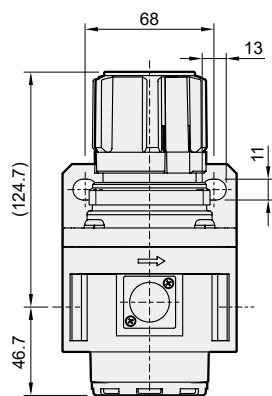
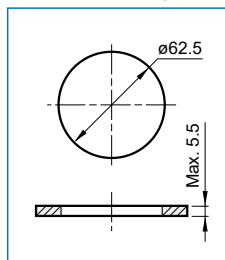

MAR900 series

PRESSURE REGULATOR



Technical data



User manual



Caution for safety
(Read before installing)



Symbol

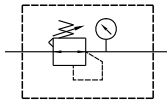

- MAR900 reducing the system pressure to a desired level and maintain it at a constant level despite change in inlet pressure and changes in downstream flow requirements.

Specification

Model	MAR900
Bore No.	40A
Port size	1 1/2
Medium	Air
Max. operating pressure	2.1 MPa
Regulated pressure range	0.09~0.86 MPa
Ambient temperature	0~+80°C (No freezing)
Standard nominal flow rate(*)	11000 ℓ/min
Attachment	Pressure gauge (PG-50)
Weight	1208 g

* Flow is at 1 MPa supply pressure and 0.1 MPa pressure drop of 0.6 MPa of secondary pressure.

Order example

MAR900 – 40A – □ – □

MODEL PORT SIZE FLOW DIRECTION PORT THREAD

40A: 1 1/2 Blank: Left to right Blank: Rc thread

R: Right to left NPT: NPT thread

Flow feature

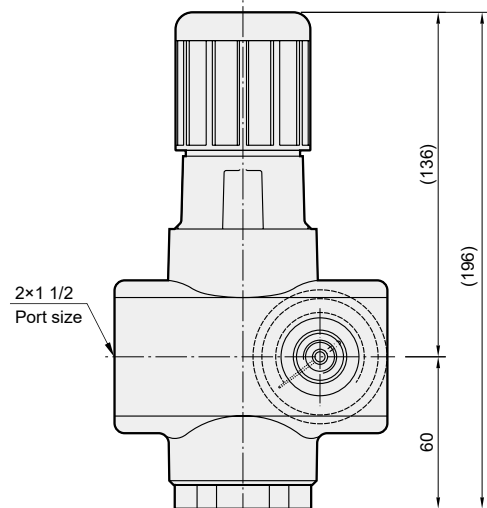
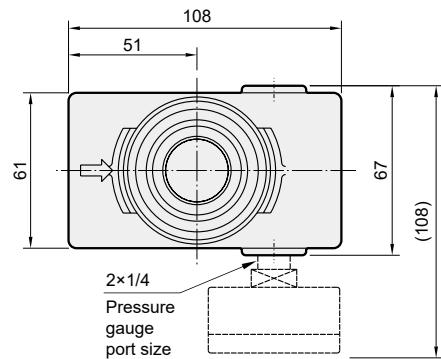
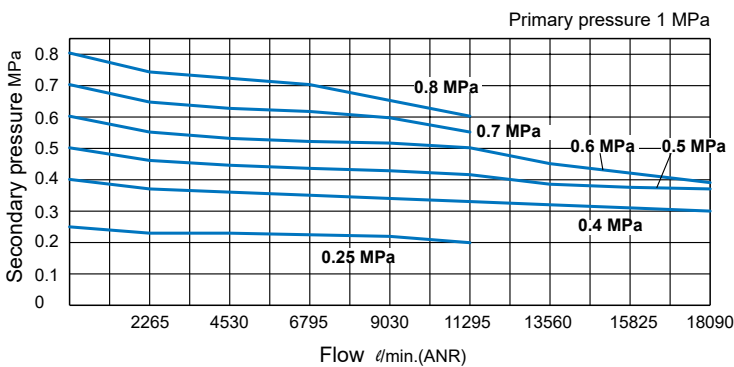

MAR901 series Pilot operated

PRESSURE REGULATOR



Technical data



User manual



Caution for safety
(Read before installing)



Symbol

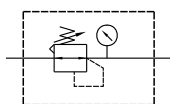

- It allows main regulator to be installed at any point in compressed air system.
- Accurate pressure regulation in a wide range of flow.

Specification

Model	MAR901
Bore No.	50A
Port size	2
Medium	Air
Max. operating pressure	3.1 MPa
Min. pilot pressure (*2)	0.15 MPa
Regulated pressure range	Up to 1.75 MPa (with the help of a pilot regulator)
Ambient temperature	0~+80°C (No freezing)
Standard nominal flow rate (*1)	59000 ℓ/min
Attachment	Pressure gauge (PG-50)
Weight	3055 g

*1. Primary pressure 1 MPa. Secondary pressure 0.6 MPa and $\Delta P = 0.1$ MPa.

*2. Minimum secondary pressure of pilot regulator.

Order example

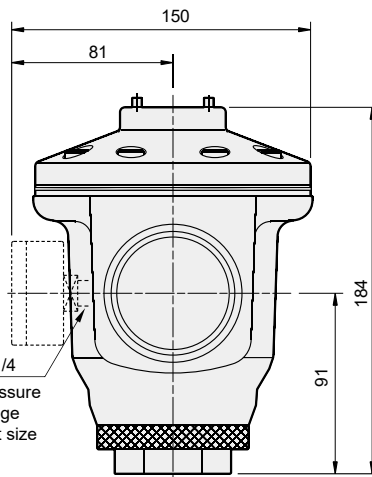
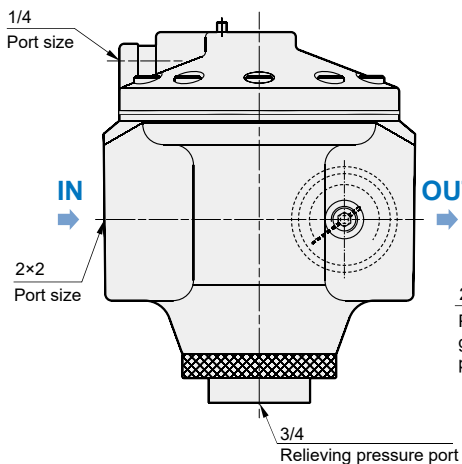
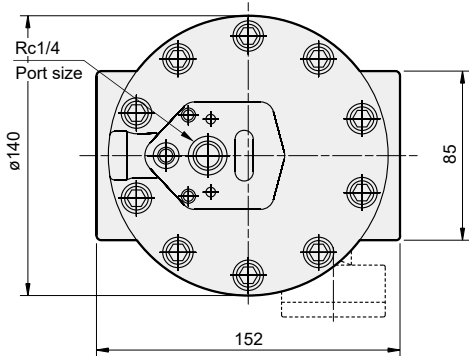
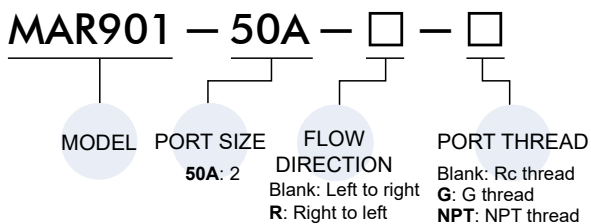

Flow feature

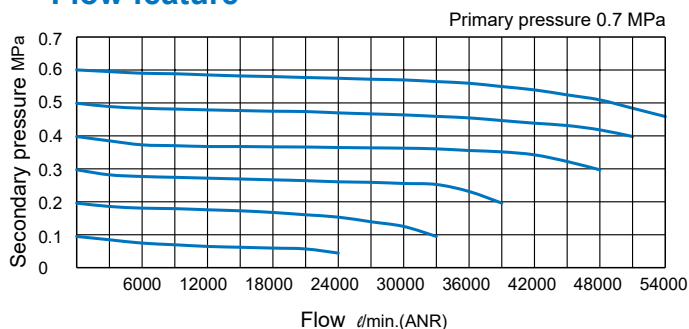

Flow ℓ/min.(ANR)

Pilot operation

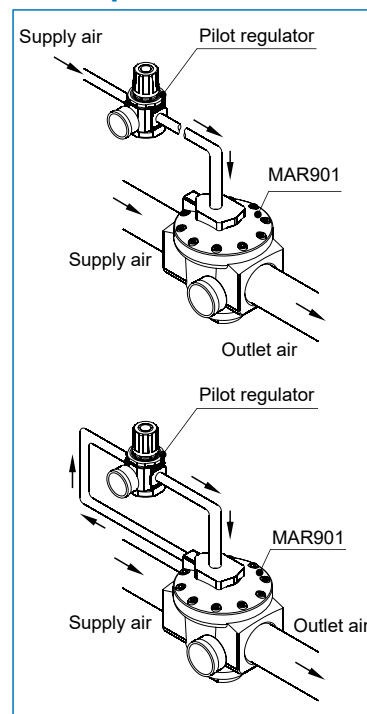

MAHR200 series

PRESSURE REGULATOR



Technical data



User manual



Caution for safety
(Read before installing)



Feature

High pressure type can regulate up to 2.7 MPa.

Specification

Model	MAHR200
Bore No.	8A
Port size	1/4
Medium	Air
Max. operating pressure	3.5 MPa
Proof pressure	5 MPa
Regulated pressure range	Standard: 0~1 MPa
	High pressure: 0~2.7 MPa
Ambient temperature	0~+60°C (No freezing)
Attachment	Standard type pressure gauge: PG-40W-8A High pressure type pressure gauge: PG-40W-8A-30k
Weight	250 g

Symbol

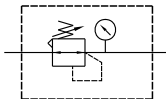

Order example

MAHR200 – 8A – □ – □

MODEL

PORT SIZE
8A: 1/4

Blank: Standard type (Gray cap)
H: High type pressure (Red cap)

PORT THREAD
Blank: Rc thread
G: G thread
NPT: NPT thread

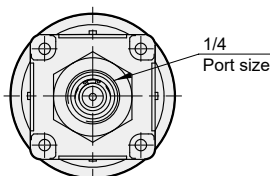
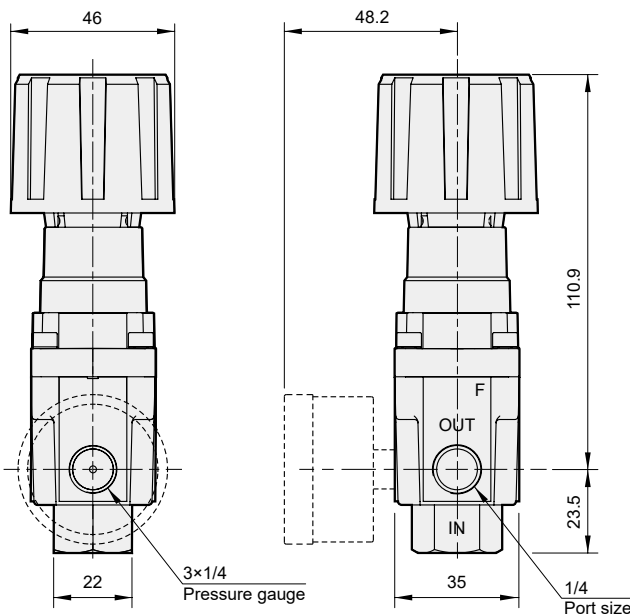

Flow feature

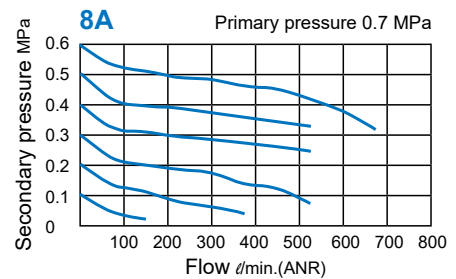

MAR300LK series

HAND-HELD REGULATOR



Features



Caution for safety
(Read before installing)



Symbol



Hand-held regulator could be directly assembled with pneumatic tools. According to the user's applications, you can regulate the pressure of pneumatic tool.

Feature

- Design: No convex shaft, small size and high transportability. Anodized aluminum body to achieve lightweight. (80g around)
- The outlet pressure can be observed through the scale of adjustment knob to determine. The lock mechanism can prevent rotation by accidentally.
- The unique structure of adjustment knob enables the pressure regulation to be completed within one turning round.
- Outlet pressure can be directly exhausted by turning back the adjustment knob.

Order example

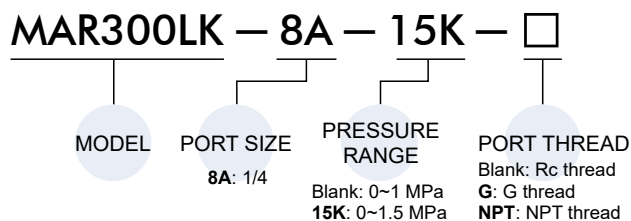

Pressure feature

* The variation in the secondary pressure, with reference to the change in the primary pressure.

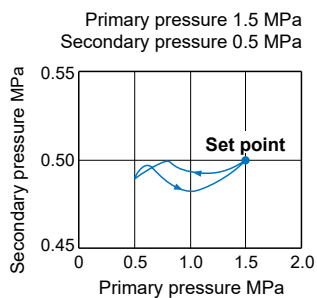
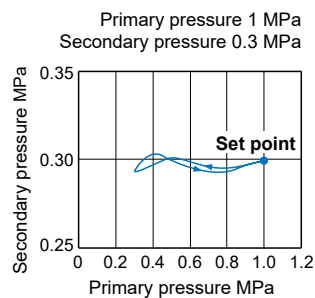

Specification

Model	MAR300LK
Bore No.	8A
Port size	1/4
Medium	Air
Max. operating pressure	1 MPa, 15K: 1.5 MPa
Proof pressure	3.75 MPa
Set pressure range	0.3~0.9 MPa
Ambient temperature	0~+60°C (No freezing)
Weight	80 g

Flow feature

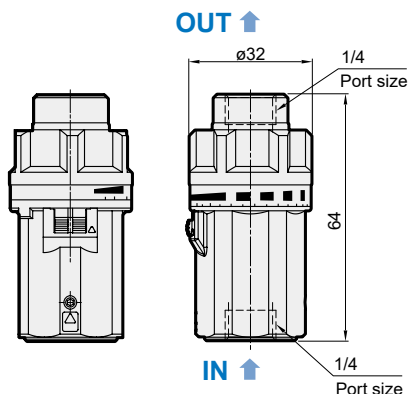
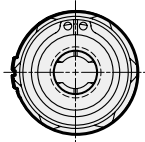
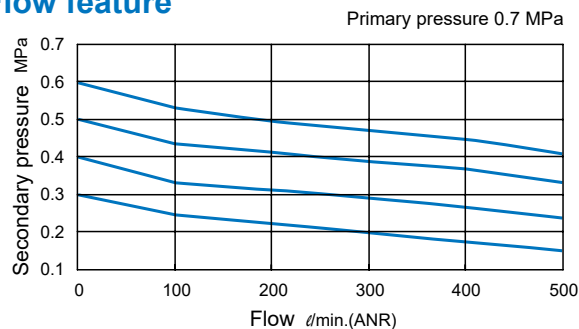

Pressure regulation

Turn the adjustment knob to regulate the pressure

Please lock the knob after regulating the pressure

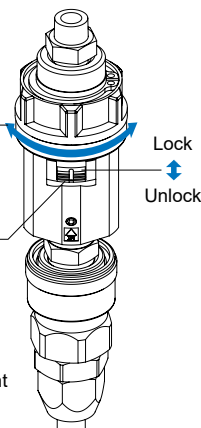

Under 1.0 MPa
General Industrial plant

Under 1.5 MPa
Automobile maintenance plant



- The pressure regulation during painting.
- The pressure regulation for nail gun.
- Torque management for operating air.

1

Stepless control

Stepless control of air pressure proportional to an electrical signal.

High precision pressure control

Achieve high precision pressure control with microcomputer PID.

Certification Comply with IP65 and CE certification.

2

Compatible with modular

MAER200, 210 can be assembled with **MA**302** series.

MAER300, 310 can be assembled with **MA**401/403** series.

1

Regulator Performance

Linearity	± 1% less (F.S.)
Hysteresis	± 0.5% less (F.S.)
Repeatability	± 0.5% less (F.S.)
Sensitivity	± 0.2% less (F.S.)

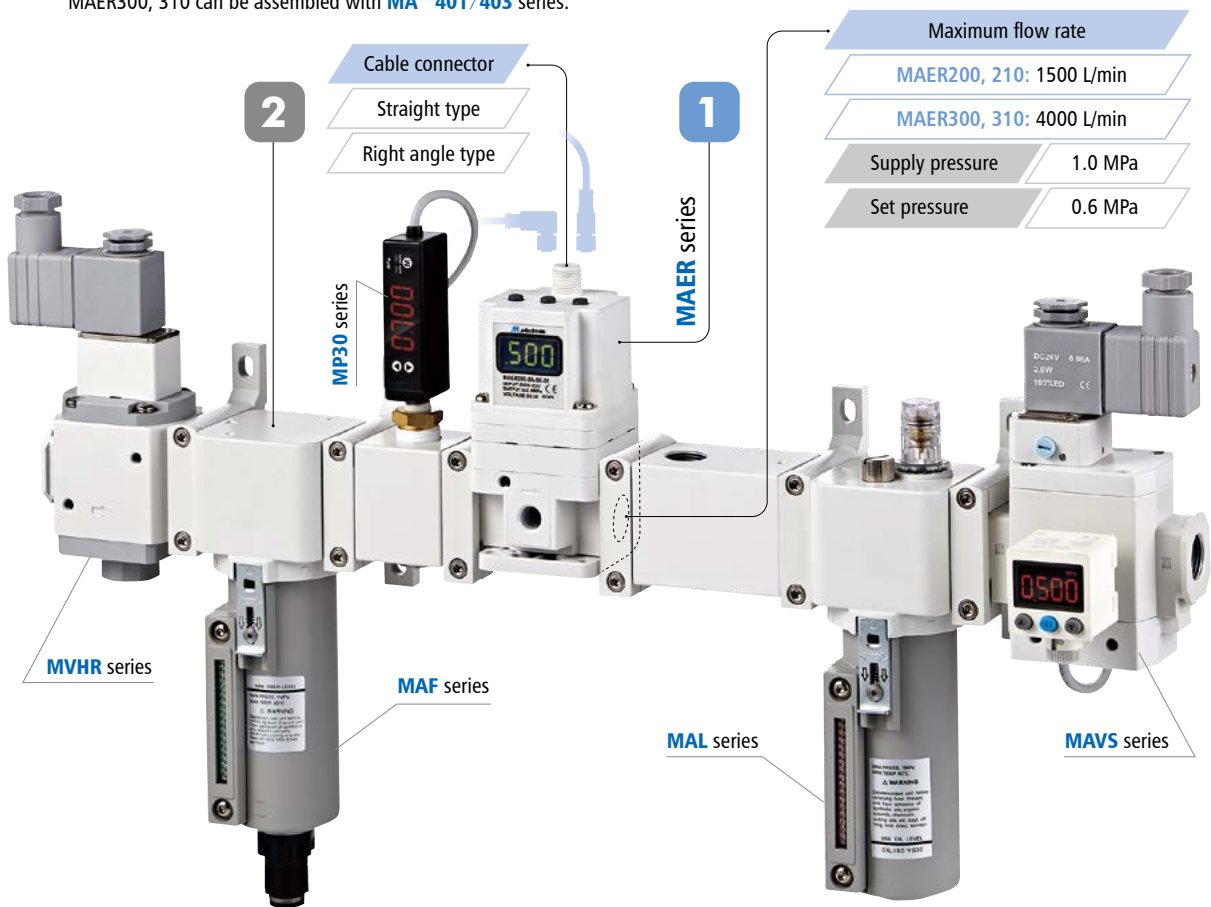

Energy saving piping

Simplify complex pipeline for controlling different pressure. Space saving, Reduce cost, Energy saving.

VS

Tradition piping

Tradition piping for multi-stage air pressure.

MAER

=

MAR + MV*

×

n SET

Pressure setting

- 0.1 MPa
- 0.3 MPa
- 0.5 MPa
- 0.7 MPa
- ...

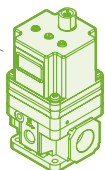

=

Regulator

Solenoid valve

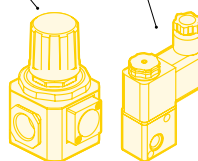

Pressure setting
0.1 MPa

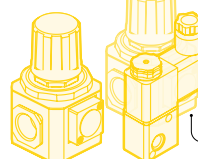

Pressure setting
0.3 MPa

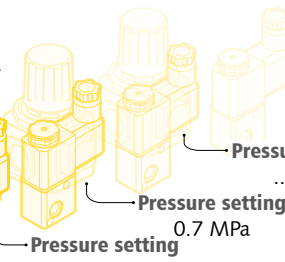

Pressure setting
... MPa

Pressure setting
0.7 MPa

Pressure setting
0.5 MPa

Complex pipeline for controlling different pressure with electrical signal.

Wiring

Connect the cable to the connector on the body with the wiring arranged as shown below.

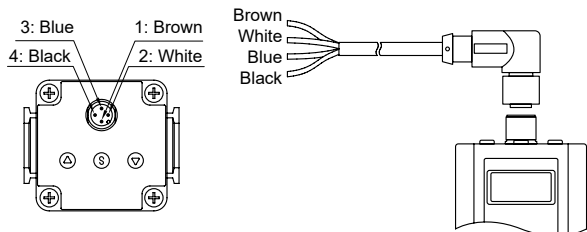

Input signal:

Current, voltage signal type

1	Brown	Power supply
2	White	Input signal
3	Blue	GND(COMMON)
4	Black	Monitor output

Input signal:

Preset input type

1	Brown	Power supply
2	White	Input signal 1
3	Blue	GND(COMMON)
4	Black	Input signal 2

* The cables are available in both straight type and right angle type. A right angle type connector is attached facing left (towards the SUP port). The direction of the straight type arrow is aligned with socket latch.

⚠ Warning

- The color of connector pins and cable conductors must be checked when wiring. Check wire color with handling precaution, since improper wire connection leads to destruction/failure and malfunction.
- When the cable plug is connected to the socket of the body, please correctly align the pins with the socket latch, and then slowly lock it downwards.
Do not force to lock, it may damage the cable plug or casing, causing malfunction or abnormality.
- Do not use power voltage exceeding specifications. The product could malfunction or catch fire if voltage exceeding the working range is applied.
- Short-circuiting the load could result in rupture or fire.

⚠ Caution

- The connection between the cable plug and the wire is weak. Excessive bending may shorten the life of the plug set, causing breakage or damage.
- If you need an anti-bending cable, please contact the sales.

Wiring diagrams

Connect the cable to the connector on the body with the wiring arranged as shown below.

Current, voltage signal type

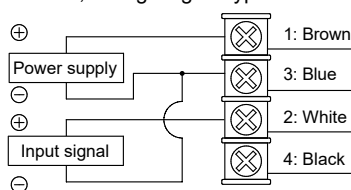

Preset input type

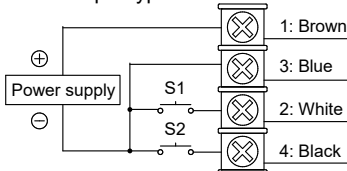

Monitor output wiring diagram

Switch output – NPN type

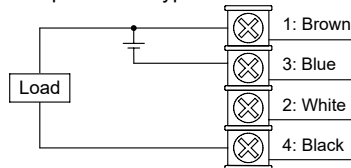

Switch output – PNP type

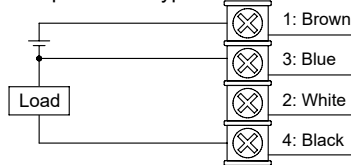

* NPN / PNP output type does not contain overcurrent protection and an error warning display, so the loop current should not exceed 160mA to avoid burning.

DC1~5V Analog output, Voltage type

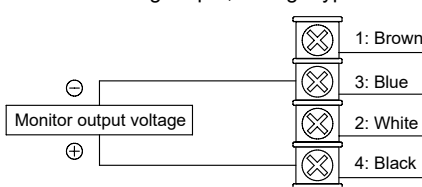

DC4~20mA Analog output, Current type (source type)

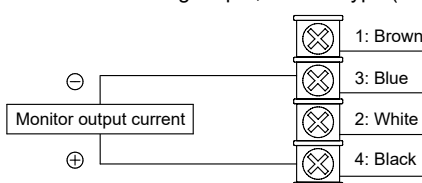

Wiring

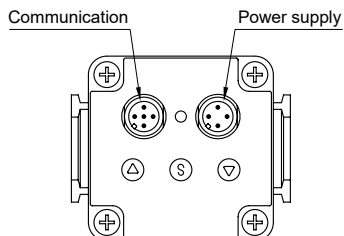

Pin assign of product connector port in RS-232 model

Port	Pin assign	Wire color ^②
Power supply ^①	1 Power supply	Brown
	2 No connect	White
	3 GND	Blue
	4 No connect	Black
Communication connect	1 No connect	Yellow
	2 T×D	Brown
	3 R×D	White
	4 GND	Green
	5 No connect	Gray

Pin assign of product connector port in RS-485 model

Port	Pin assign	Wire color ^②
Power supply ^①	1 Power supply	Brown
	2 No connect	White
	3 GND	Blue
	4 No connect	Black
Communication connect	1 No connect	Yellow
	2 B(-)	Brown
	3 A(+)	White
	4 GND	Green
	5 No connect	Gray

⚠ Warning

- ① The pin-2 and pin-4 of power supply port must be prevent to connect any signal to avoid interference or malfunction.
- ② Wire color is when the option cable is used.
- ③ Do not use power voltage exceeding specifications. The product could malfunction or catch fire if voltage exceeding the working range is applied.
- ④ Please pay attention to shielding the unused pins to avoid malfunction or abnormal function caused by noise.

Operating environment

⚠️ Caution

- ❶ Avoid using this regulator where it will be subject to direct sunlight, water or oil, etc.
- ❷ Use in place where the temperature changes drastically or at high humidity may cause damage due to dew condensation in the product.

Air supply

⚠️ Caution

- ❶ Use clean compressed air that does not contain corrosive gas. Poor air quality adversely affects function and life.
- ❷ For the pneumatic source, use cleaned air from which the solid, water and oil contents were eliminated sufficiently, using an air dryer, filter and oil mist filter. Recommend selecting a filtration precision of 5µm or less.
- ❸ Do not use a lubricator on the supply side of this product, the lubricated air might cause malfunction. When lubrication of terminal equipment is necessary, connect a lubricator on the output side of the equipment and set a check valve.
- ❹ When the secondary pressure is lowered with an input signal, the secondary air passes through the product and is discharged from the EXH port. Contamination on the secondary piping and the inside of the load will have an adverse effect on performance, etc. Keep the inside of the piping as clean as possible.
- ❺ Tighten pipes with the appropriate torque to prevent air leakage and screw damage. First tighten the screw by hand to prevent damage to screw threads, then use a tool.
- ❻ Tighten pipes with the appropriate torque. Pipes must be connected with the appropriate torque to prevent air leakages and screw damage. First tighten the screw by hand to prevent damage to screw threads, then use a tool.

Handling

⚠️ Caution

- ❶ If supply pressure to this product is interrupted while the power is still on, the internal solenoid valve will continue to operate and a humming noise may be generated. Since the life of the product may be shortened, shut off the power supply also when supply pressure is shut off.
- ❷ IF electric power is shut off while pressure is being applied, pressure will be retained on the output side. However, this output pressure is held only temporarily and is not guaranteed.
- ❸ The product characteristics are confined to no flow in the pipeline. When air is consumed on the output side, pressure may become unstable.
- ❹ Refer to the operation manual included with the product for details on its handling.
- ❺ When the appliance set standby with 0 kPa input, please input an offset signal of residual pressure. If not, the inner solenoid valve will overaction to cut down the product lifespan.

- ❻ Even when pressure is set to 0 MPa, secondary side pressure will not be completely released with less than 1%F.S. remaining. If precisely 0 MPa is required, bleed the secondary side or install a 3-way valve on the secondary side to switch the secondary side to atmospheric pressure.

⚠️ Warning

- ❶ Do not use input signal exceeding specifications. This product could malfunction fire if input signal exceeding the working range is applied.
- ❷ This product is adjusted for each specification at the time of shipment from the factory. Disassembling and reformation are prohibited, as this way might lead to malfunction.
- ❸ If an abnormality occurs during operation, immediately turn off the power and air pressure and stop using it.

Terms

- ❶ **Proof pressure:** The value of the maximum pressure that the device can endure and not to malfunction.
- ❷ **Setting pressure range:** The range of the controllable pressures. Control is stopped when the input signal becomes 1% F.S. or lower.

Note. This is different from the accuracy guarantee range. See the item of linearity and hysteresis side.

- ❸ **Linearity:** The error of the linear output relative to the ideal straight line, i.e. the accuracy of the analog output. It is usually expressed as a percentage compared to the entire measurement range (Full Scale: F.S.), such as 1% F.S..
- ❹ **Hysteresis:** Hysteresis is the maximum difference between the rising curve and the falling curve when the input signal is varied from 0% to 100% and 100% to 0%, indicated by the percentage relative to the full scale.
- ❺ **Repeatability:** Repeatability is the maximum deviation of control pressure measured when the same input signal is applied repeatedly in a short time and under the same operating conditions. Repeatability is indicated by the percentage relative to the full scale.
- ❻ **Sensitivity:** Sensitivity is the minimum value of the input signal that changes the control pressure, indicated by the percentage relative to the full scale.
- ❼ **Temperature characteristics:** The difference of the control pressure level made by 1°C difference of the ambient temperature (with reference temperature 25°C) is converted by calculation.

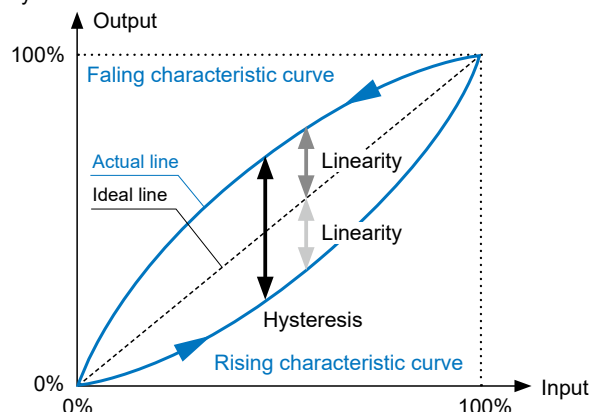



Features



User manual



Caution for safety
(Read before installing)



Feature

- Stepless control of air pressure proportional to an electrical signal.
- Simplify complex pipeline for controlling different pressure.
- MAER200 can be assembled with MA**302 series.
- Achieve high precision pressure control with microcomputer PID.
- Maximum flow rate 1500 L/min (Supply pressure 1.0 MPa, Set pressure 0.6 MPa).
- Comply with IP65 and CE certification.

Symbol

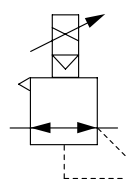

Specification

Model	MAER200		
Pressure range	1K	5K	9K
Bore No.	8A, 10A		
Port size	1/4, 3/8		
Medium	Air		
Proof pressure	0.3 MPa	1.5 MPa	
Ambient temperature	+5~+50°C (No condensation)		
Min. supply pressure	Set pressure +0.1 MPa		
Max. supply pressure	0.2 MPa	0.7 MPa	1 MPa
Setting pressure range (*1)	0.005~0.1 MPa	0.005~0.5 MPa	0.009~0.9 MPa
Power supply	Connector	M12 plug, 4-pin, A-coded	
	Voltage	DC24V±10%	
	Current	DC24V: 80mA or less	
Signal input	Current type	DC4~20 mA	
	Voltage type	DC0~5V, DC0~10V	
	Preset input (*2)	4 points	
Input impedance	Current type	≤ 400Ω	
	Voltage type	Approx. ≤ 50kΩ	
	Preset type	Approx. ≤ 1000kΩ	
Signal output (Monitor output)	Analog output	Voltage type DC1~5V (Load impedance 1kΩ or above) Output accuracy ±6% F.S. or less Current type DC4~20mA (Load impedance 750Ω or less) Output accuracy ±6% F.S. or less	
	Switch output	NPN,PNP: Max. 24V, 160mA	
Linearity	Within ±1% (F.S.)		
Hysteresis	Within 0.5% (F.S.)		
Repeatability	Within ±0.5% (F.S.)		
Sensitivity	Within 0.2% (F.S.)		
Temperature characteristics	Within ±0.2% (F.S.)/°C		
Output pressure display (*3)	Precision	±2% F.S. ±1 digit	
	Min. unit	MPa:0.001, kgf/cm ² :0.01, bar:0.01, psi:0.1, kPa:1	
Enclosure	Equivalent to IP65		
Accessories	Cable with connector: M124A-** 		
Weight	Main: 360 g; Bracket: Approx. 86g(B1), 80g(B2); Cable with connector: Approx. 55g(1m), 130g(3m)		

*1. Minimum setting pressure is equal to 1% F.S..

*2. For safety reasons, it is recommended that one of the preset pressures be set to 0 MPa.

*3. Linearity setting and preset pressure setting value both are set by the minimum unit of the output pressure display.

*4. The above characteristics are confined to no flow in the pipeline. When air is consumed on the output side, pressure may become unstable.

*5. The above characteristics apply for a control pressure of 10% to 90% when power voltage is 24 VDC, ambient temperature is 25±3°C, no-loading and working pressure is maximum control pressure.

MAER200 Order example & Interface pin

AIR UNIT (ELECTRO – PNEUMATIC REGULATOR)



Order example

MAER200 – 8A – 9K – 1 1 1 – B1 S1 – □

MODEL

PORT SIZE

8A: 1/4
10A: 3/8

PRESSURE RANGE

1K: 0.1 MPa (*)
5K: 0.5 MPa
9K: 0.9 MPa

BRACKET

Blank: Without
B1: L type
B2: Flat type

CABLE CONNECTOR

Blank: Without
S1: Straight 1m
S3: Straight 3m
L1: Right angle 1m
L3: Right angle 3m

PORT THREAD

Blank: Rc thread
G: G thread
NPT: NPT thread

SIGNAL INPUT	SIGNAL OUTPUT	PRESSURE DISPLAY UNIT
1: Current DC4~20mA 2: Voltage DC0~10V 3: Voltage DC0~5V (*) 40: Preset input (*)	1: Analog output DC1~5V 2: Switch output NPN 3: Switch output PNP 4: Analog output DC4~20mA (Source type)	1: MPa 2: kgf/cm ² 3: bar 4: psi 5: kPa
	–	

* Made to order.

Exterior

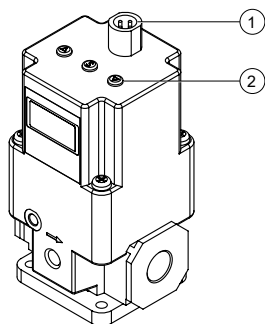

No.	Item	Description
1	Power connector	M12 plug, 4-pin, A-coded (male)
2	Operation button	Mode settings

Interface pin

① Signal input: Current / voltage type

Fig	Pin	Signal
	1	24V
	2	Signal input
	3	0V GND
	4	Monitoring output

① Signal input: Preset input type

Fig	Pin	Signal
	1	24V
	2	Signal input 1
	3	0V GND
	4	Signal input 2

MAER200 Capacity

AIR UNIT (ELECTRO – PNEUMATIC REGULATOR)



MAER200-1K

Linearity

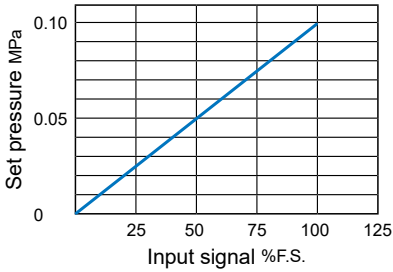

Repeatability

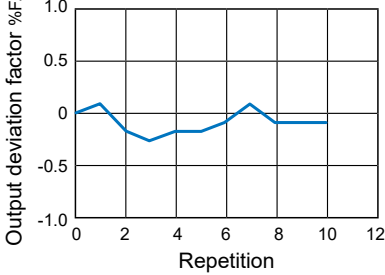

Pressure characteristics

Set pressure 0.05 MPa

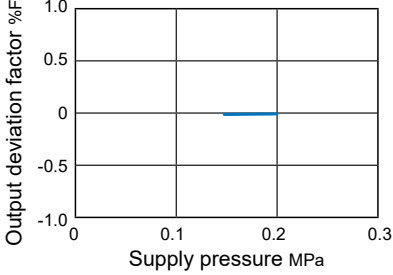

Flow rate characteristics

Supply pressure 0.2 MPa

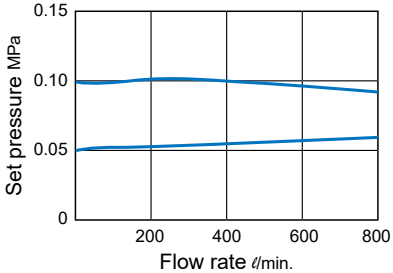

Relief flow characteristics

Back pressure 0.2 MPa

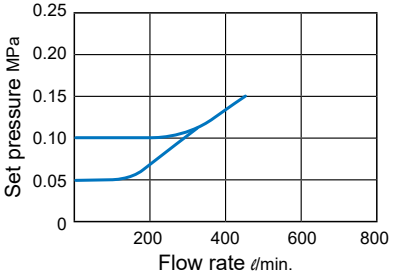

MAER200-5K

Linearity

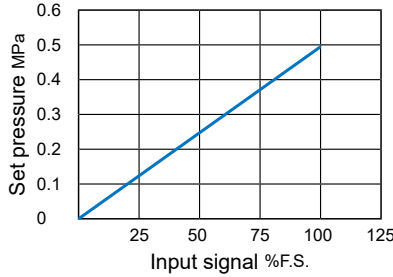

Repeatability

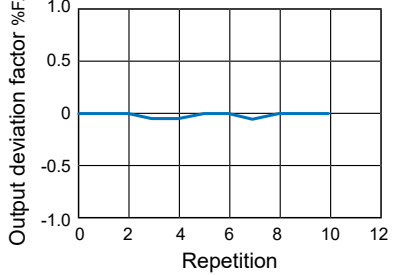

Pressure characteristics

Set pressure 0.2 MPa

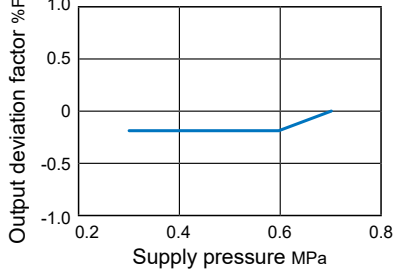

Flow rate characteristics

Supply pressure 0.7 MPa

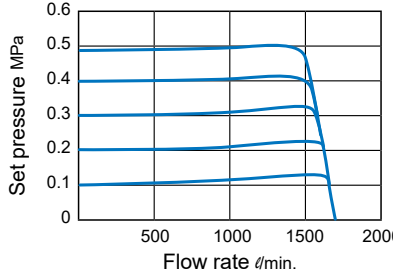

Relief flow characteristics

Back pressure 0.7 MPa

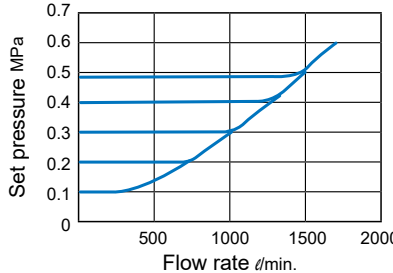

MAER200-9K

Linearity

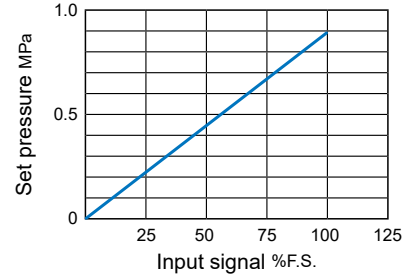

Repeatability

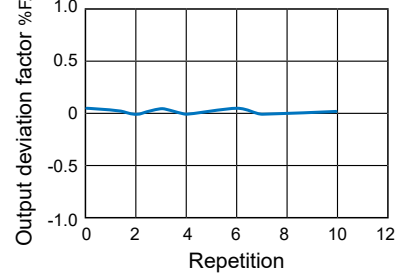

Pressure characteristics

Set pressure 0.4 MPa

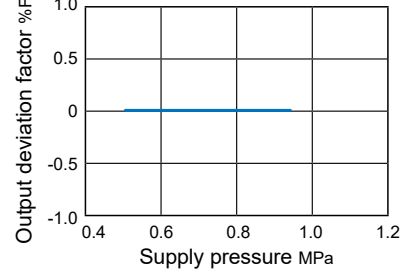

Flow rate characteristics

Supply pressure 1.0 MPa

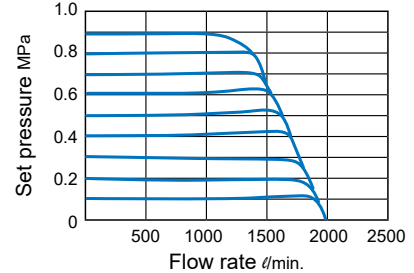

Relief flow characteristics

Back pressure 1.0 MPa

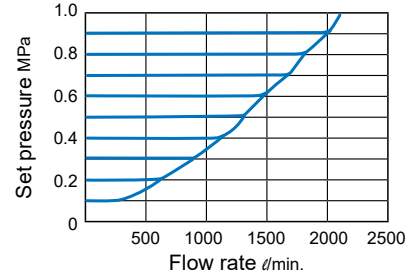

MAER200 Dimensions

AIR UNIT (ELECTRO – PNEUMATIC REGULATOR)



MAER200-* -B1

L type bracket

MAER200-* -B2

Flat type bracket

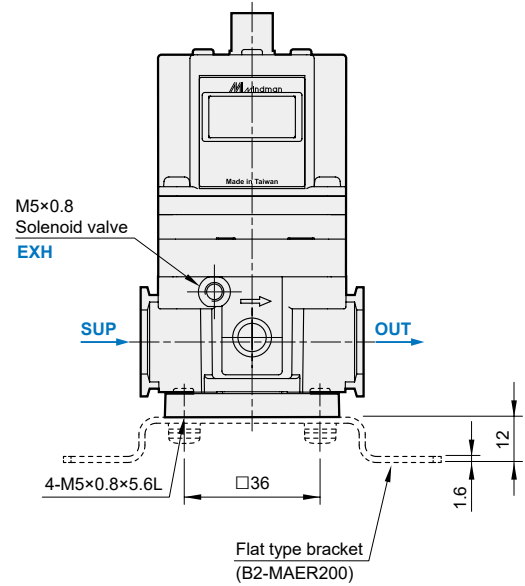
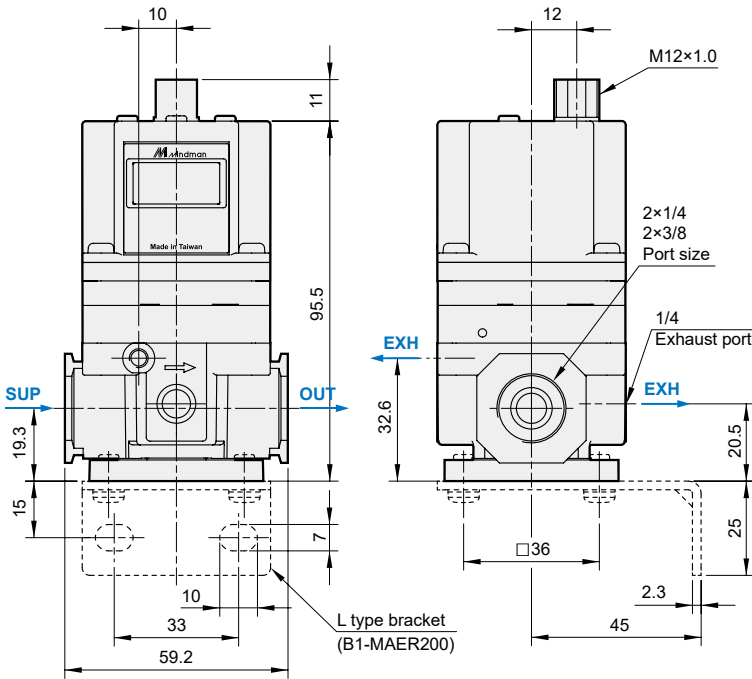
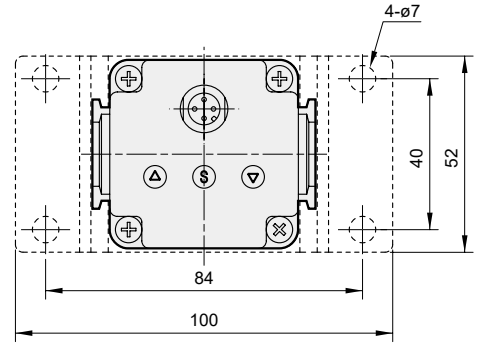
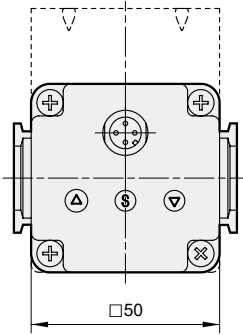

MAER210 series

AIR UNIT (ELECTRO – PNEUMATIC REGULATOR)



Features



RS-232 manual



RS-485 manual



Caution for safety
(Read before installing)



Feature

- Stepless control of air pressure proportional to an electrical signal.
- Simplify complex pipeline for controlling different pressure.
- MAER210 can be assembled with MA**302 series.
- Achieve high precision pressure control with microcomputer PID.
- Maximum flow rate 1500 L/min (Supply pressure 1.0 MPa, Set pressure 0.6 MPa).
- Comply with IP65 and CE certification.

Symbol

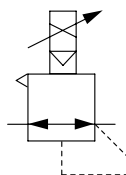

Specification

Model	MAER210		
Pressure range	1K	5K	9K
Bore No.	8A, 10A		
Port size	1/4, 3/8		
Medium	Air		
Proof pressure	0.3 MPa	1.5 MPa	
Ambient temperature	+5~+50°C (No condensation)		
Min. supply pressure	Set pressure +0.1 MPa		
Max. supply pressure	0.2 MPa	0.7 MPa	1 MPa
Setting pressure range (*1)	0.005~0.1 MPa	0.005~0.5 MPa	0.009~0.9 MPa
Power supply	Connector	M12 plug, 4-pin, A-coded	
	Voltage	DC24V±10%	
	Current	180mA or less	
Precision	Linearity	Within ±1% (F.S.)	
	Hysteresis	Within 0.5% (F.S.)	
	Repeatability	Within ±0.5% (F.S.)	
	Sensitivity	Within 0.2% (F.S.)	
Temperature characteristics	Within ±0.2% (F.S.)/°C		
Output pressure display (*2)	Precision	±2% F.S. ±1 digit	
	Min. unit	MPa:0.001, kgf/cm ² :0.01, bar:0.01, psi:0.1, kPa:1	
Enclosure	IP65		
Accessories of cable with connector	Power: M124A-** , Communication: M125A-**		
Weight	Main	410 g	
	Accessories	Bracket: Approx. 86g(B1) , 80g(B2); Power cable with connector: Approx. 130g(3m) Communication cable with connector: Approx. 140g(3m)	

Communication type

Protocol	RS-232	RS-485
Input connector	M12 plug, 5-pin, A-coded	M12 plug, 5-pin, A-coded
Address	1	1~248
Comm. speed	9.6k / 19.2k / 38.4k bps	9.6k / 19.2k / 38.4k bps
Comm. interface	Modbus ASCII	Modbus RTU

*1. Minimum setting pressure is equal to 1% F.S..

*2. Linearity setting and preset pressure setting value both are set by the minimum unit of the output pressure display.

*3. The above characteristics are confined to no flow in the pipeline. When air is consumed on the output side, pressure may become unstable.

*4. The above characteristics apply in a control pressure of 10% to 90% when power voltage is 24 VDC, ambient temperature is 25±3°C, no-loading and working pressure set at the maximum control pressure.

MAER210 Order example & Interface pin



AIR UNIT (ELECTRO – PNEUMATIC REGULATOR)

mindman

Order example

MAER210 – 8A – 9K – 10 1 – B1 S3 CS – □

MODEL

PORT SIZE
8A: 1/4
10A: 3/8

PRESSURE RANGE
1K: 0.1 MPa (*)
5K: 0.5 MPa
9K: 0.9 MPa
* Made to order.

PRESSURE DISPLAY UNIT
1: MPa
2: kgf/cm²
3: bar
4: psi
5: kPa

POWER CABLE
Blank: Without
S3: Straight 3m
L3: Right angle 3m

PORT THREAD
Blank: Rc thread
G: G thread
NPT: NPT thread

COMMUNICATION MODEL
10: RS-232
20: RS-485

BRACKET
Blank: Without
B1: L type
B2: Flat type

COMMUNICATION CABLE
Blank: Without
CS: Straight 3m
CL: Right angle 3m

Exterior

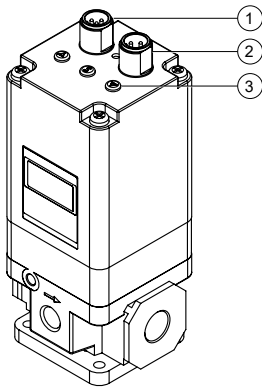

No.	Item	Description
1	Power connector	M12 plug, 4-pin, A-coded (male)
2	Communication connector	M12 plug, 5-pin, A-coded (male)
3	Operation button	Mode settings

Interface pin

RS-232

① Power interface		
Fig	Pin	Signal
	1	24V
	2	-
	3	0V GND
	4	-

② Communication connector		
Fig	Pin	Signal
	1	-
	2	TxD
	3	RxD
	4	GND
	5	-

RS-485

① Power interface		
Fig	Pin	Signal
	1	24V
	2	-
	3	0V GND
	4	-

② Communication connector		
Fig	Pin	Signal
	1	-
	2	B(-)
	3	A(+)
	4	GND
	5	-

MAER210 Capacity

AIR UNIT (ELECTRO – PNEUMATIC REGULATOR)



MAER210-5K

Linearity

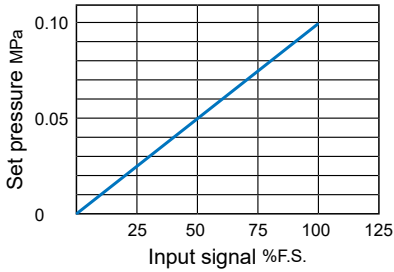

Repeatability

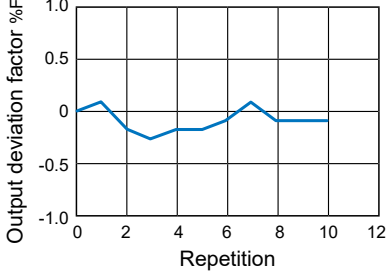

Pressure characteristics

Set pressure 0.05 MPa

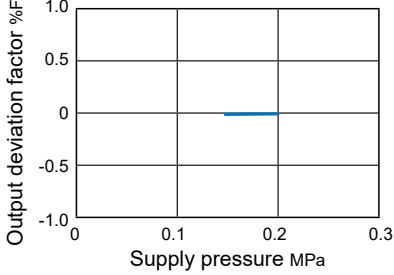

Flow rate characteristics

Supply pressure 0.2 MPa

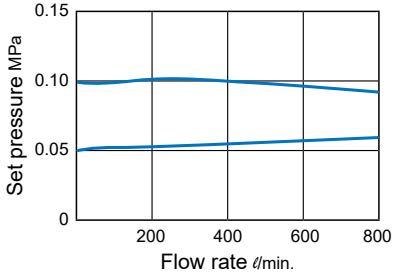

Relief flow characteristics

Back pressure 0.2 MPa

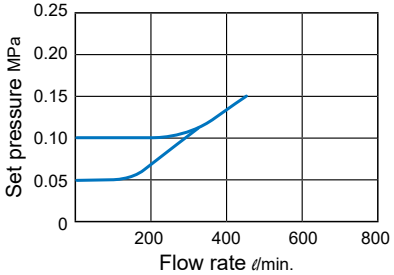

MAER210-9K

Linearity

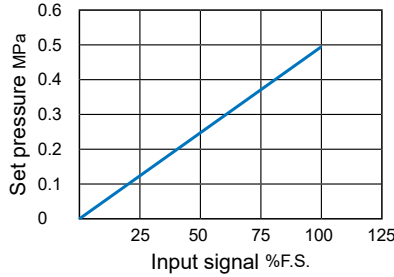

Repeatability

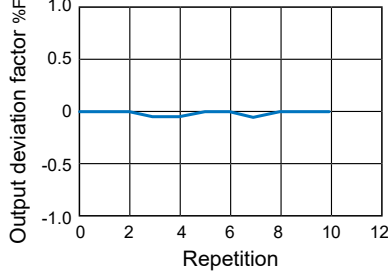

Pressure characteristics

Set pressure 0.2 MPa

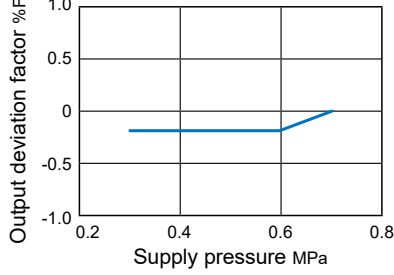

Flow rate characteristics

Supply pressure 0.7 MPa

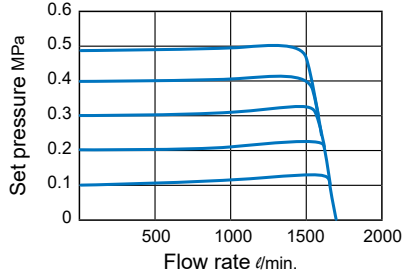

Relief flow characteristics

Back pressure 0.7 MPa

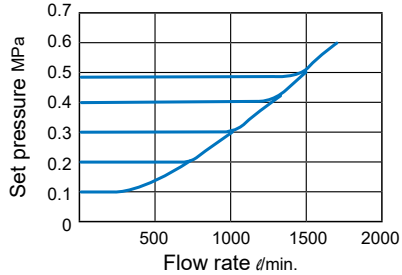

MAER210-1K

Linearity

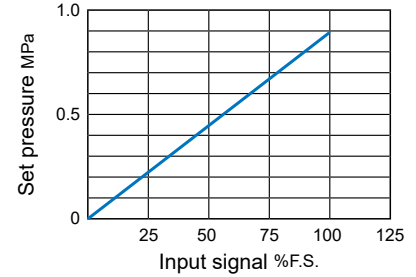

Repeatability

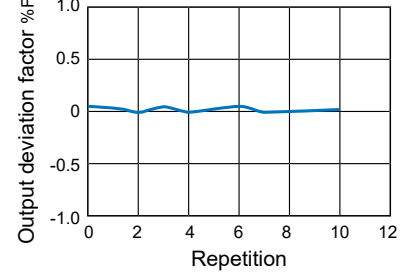

Pressure characteristics

Set pressure 0.4 MPa

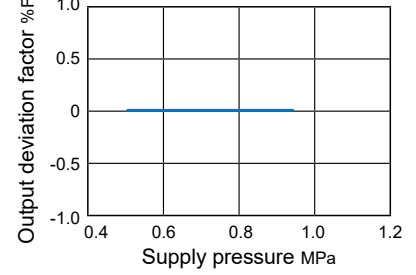

Flow rate characteristics

Supply pressure 1.0 MPa

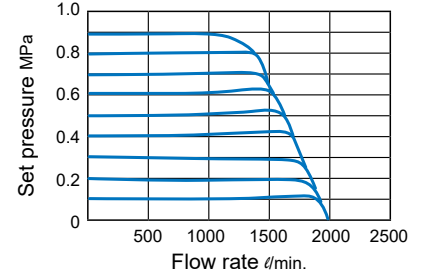

Relief flow characteristics

Back pressure 1.0 MPa

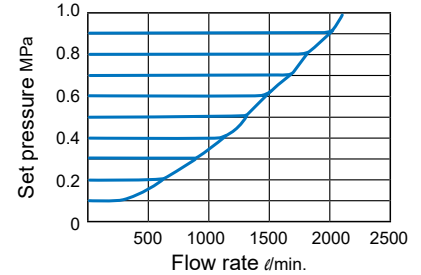

MAER210 Dimensions

AIR UNIT (ELECTRO – PNEUMATIC REGULATOR)



MAER210-* -B1

L type bracket

MAER210-* -B2

Flat type bracket

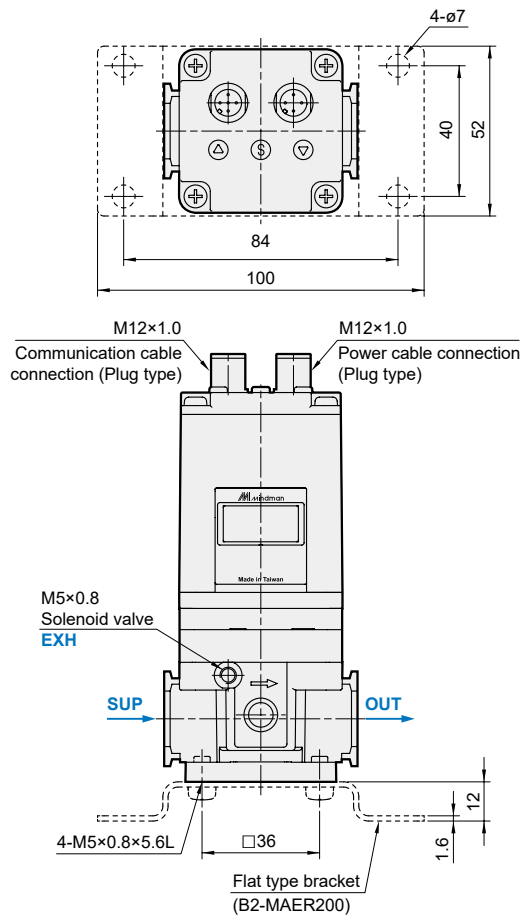
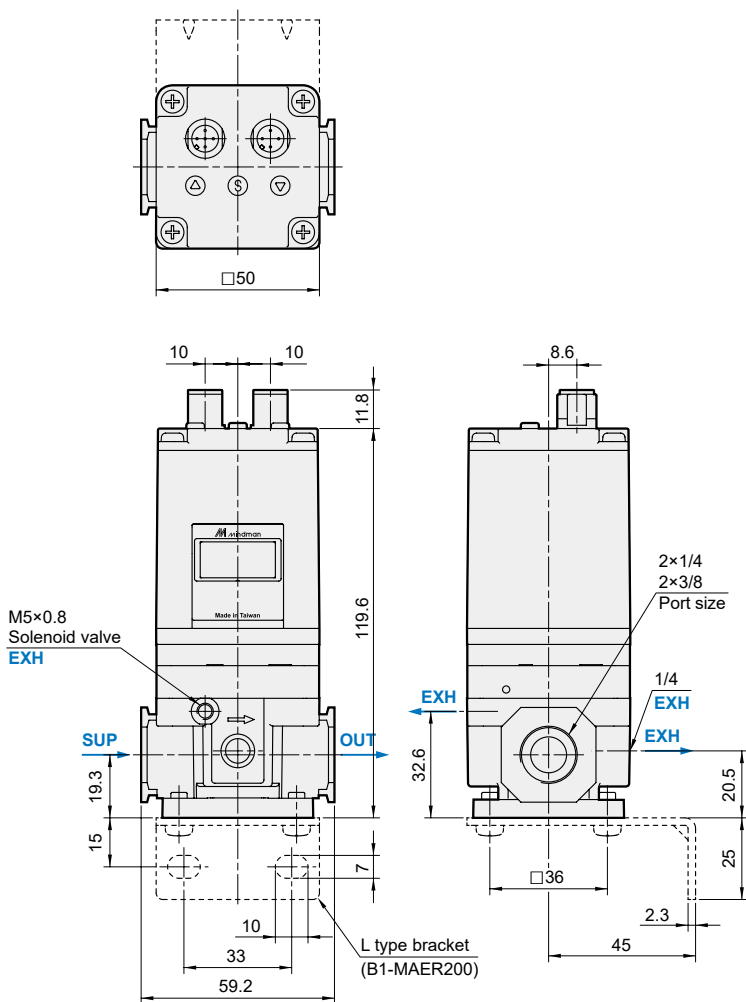

MAER300 series

AIR UNIT (ELECTRO – PNEUMATIC REGULATOR)



Features



User manual



Caution for safety
(Read before installing)



Feature

- Stepless control of air pressure proportional to an electrical signal.
- Simplify complex pipeline for controlling different pressure.
- MAER300 can be assembled with MA**401/403 series.
- Achieve high precision pressure control with microcomputer PID.
- Maximum flow rate 4000 L/min (Supply pressure 1.0 MPa, Set pressure 0.6 MPa).
- Comply with IP65 and CE certification.

Symbol

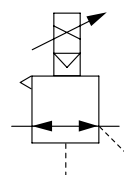

Specification

Model		MAER300		
Pressure range		1K	5K	9K
Bore No.		8A, 10A, 15A		
Port size		1/4, 3/8, 1/2		
Medium		Air		
Proof pressure		0.3 MPa	1.5 MPa	
Ambient temperature		+5~+50°C (No condensation)		
Min. supply pressure		Set pressure +0.1 MPa		
Max. supply pressure		0.2 MPa	0.7 MPa	1 MPa
Setting pressure range (*1)		0.005~0.1 MPa	0.005~0.5 MPa	0.009~0.9 MPa
Power supply	Connector	M12 plug, 4-pin, A-coded		
	Voltage	DC24V±10%		
	Current	DC24V: 80mA or less		
Signal input	Current type	DC4~20 mA		
	Voltage type	DC0~5V, DC0~10V		
	Preset input (*2)	4 points		
Input impedance	Current type	≤ 400Ω		
	Voltage type	Approx. ≤ 50kΩ		
	Preset type	Approx. ≤ 1000kΩ		
Signal output (Monitor output)	Analog output	Voltage type DC1~5V (Load impedance 1kΩ or above) Output accuracy ±6% F.S. or less		
	Switch output	Current type DC4~20mA (Load impedance 750Ω or less) Output accuracy ±6% F.S. or less		
Linearity		NPN,PNP: Max. 24V, 160mA		
Hysteresis		Within ±1% (F.S.)		
Repeatability		Within 0.5% (F.S.)		
Sensitivity		Within ±0.5% (F.S.)		
Temperature characteristics		Within 0.2% (F.S.)/°C		
Output pressure display (*3)	Precision	±2% F.S. ±1 digit		
	Min. unit	MPa:0.001, kgf/cm ² :0.01, bar:0.01, psi:0.1, kPa:1		
Enclosure		Equivalent to IP65		
Accessories		Cable with connector: M124A-**		
Weight	Main	690 g		
	Accessories	Bracket: Approx. 86g(B1) , 80g(B2); Cable with connector: Approx. 55g(1m) , 130g(3m)		

*1. Minimum setting pressure is equal to 1% F.S..

*2. For safety reasons, it is recommended that one of the preset pressures be set to 0 MPa.

*3. Linearity setting and preset pressure setting value both are set by the minimum unit of the output pressure display.

*4. The above characteristics are confined to no flow in the pipeline. When air is consumed on the output side, pressure may become unstable.

*5. The above characteristics apply in a control pressure of 10% to 90% when power voltage is 24 VDC, ambient temperature is 25±3°C, no-loading and working pressure set at the maximum control pressure.

MAER300 Order example & Interface pin

AIR UNIT (ELECTRO – PNEUMATIC REGULATOR)



Order example

MAER300 – 8A – 9K – 1 1 1 – B1 S1 – □

MODEL

PORT SIZE

8A: 1/4
10A: 3/8
15A: 1/2

PRESSURE RANGE

1K: 0.1 MPa (*)
5K: 0.5 MPa
9K: 0.9 MPa

BRACKET

Blank: Without
B1: L type
B2: Flat type

CABLE CONNECTOR

Blank: Without
S1: Straight 1m
S3: Straight 3m
L1: Right angle 1m
L3: Right angle 3m

PORT THREAD

Blank: Rc thread
G: G thread
NPT: NPT thread

SIGNAL INPUT	SIGNAL OUTPUT	PRESSURE DISPLAY UNIT
1: Current DC4~20mA 2: Voltage DC0~10V 3: Voltage DC0~5V (*) 40: Preset input (*)	1: Analog output DC1~5V 2: Switch output NPN 3: Switch output PNP 4: Analog output DC4~20mA (Source type)	1: MPa 2: kgf/cm ² 3: bar 4: psi 5: kPa
	–	

* Made to order.

Exterior

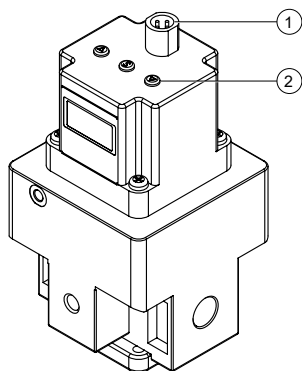

No.	Item	Description
1	Power connector	M12 plug, 4-pin, A-coded (male)
2	Operation button	Mode settings

Interface pin

① Signal input: Current / voltage type

Fig	Pin	Signal
	1	24V
	2	Signal input
	3	0V GND
	4	Monitoring output

① Signal input: Preset input type

Fig	Pin	Signal
	1	24V
	2	Signal input 1
	3	0V GND
	4	Signal input 2

MAER300-1K

Linearity

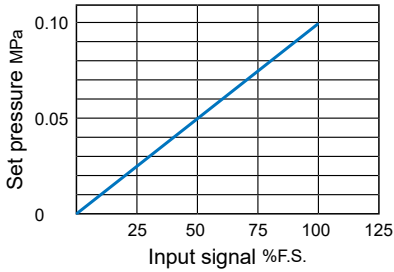

Repeatability

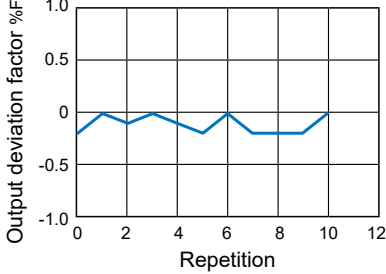

Pressure characteristics

Set pressure 0.05 MPa

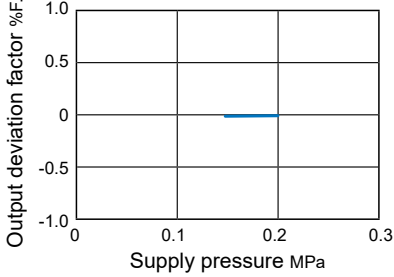

Flow rate characteristics

Supply pressure 0.2 MPa

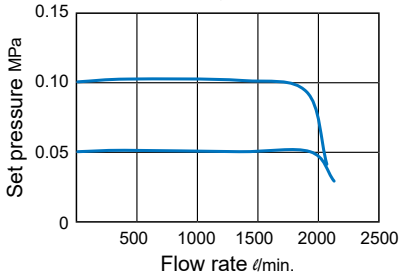

Relief flow characteristics

Back pressure 0.2 MPa

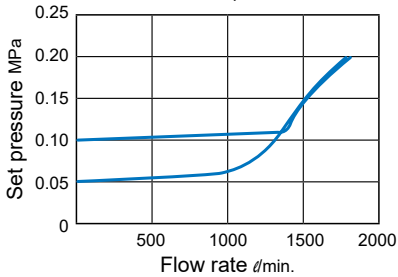

MAER300-5K

Linearity

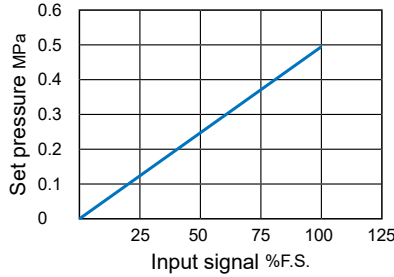

Repeatability

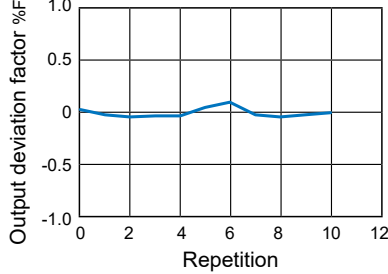

Pressure characteristics

Set pressure 0.2 MPa

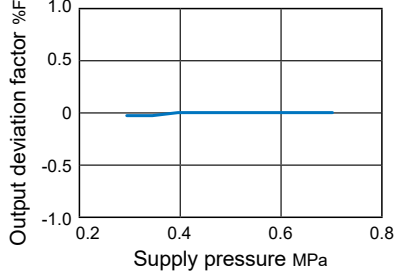

Flow rate characteristics

Supply pressure 0.7 MPa

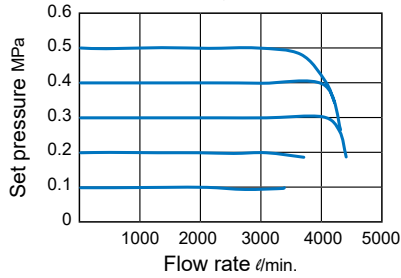

Relief flow characteristics

Back pressure 0.7 MPa

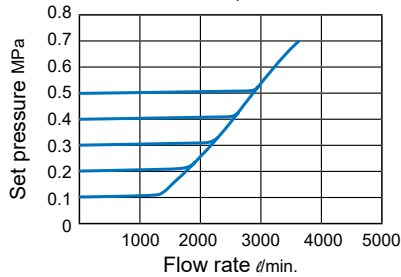

MAER300-9K

Linearity

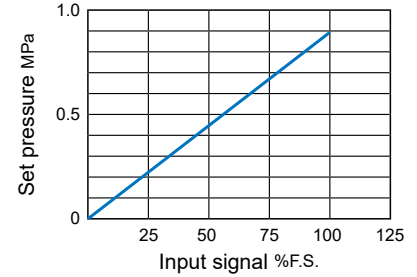

Repeatability

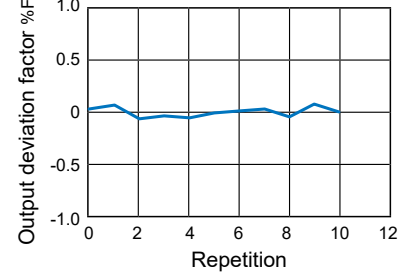

Pressure characteristics

Set pressure 0.4 MPa

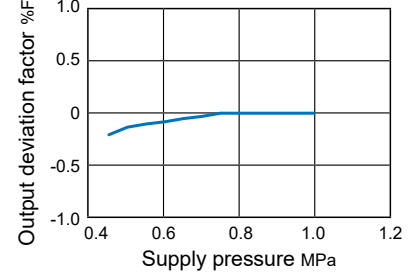

Flow rate characteristics

Supply pressure 1.0 MPa

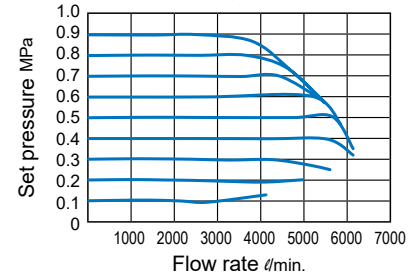

Relief flow characteristics

Back pressure 1.0 MPa

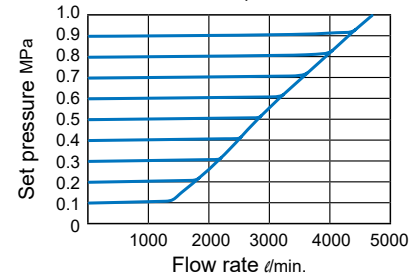

MAER300 Dimensions

AIR UNIT (ELECTRO – PNEUMATIC REGULATOR)



MAER300-* -B1

L type bracket

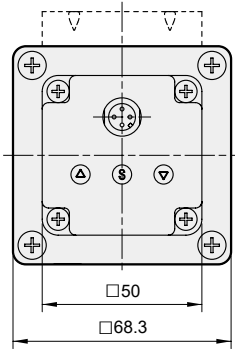

MAER300-* -B2

Flat type bracket

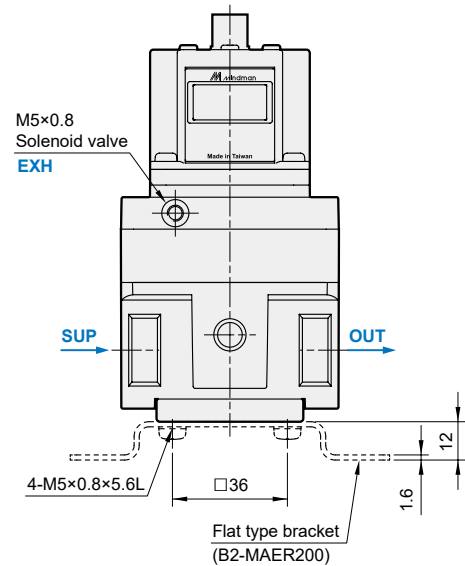
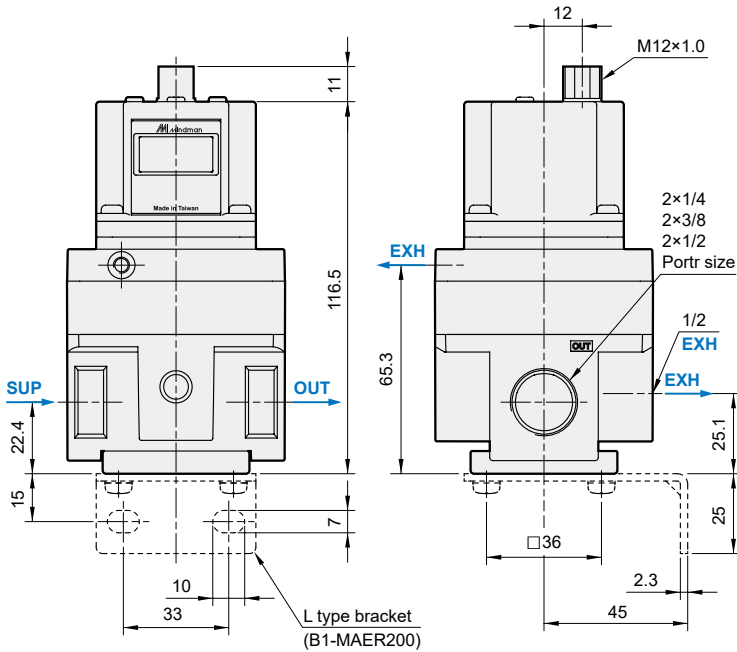
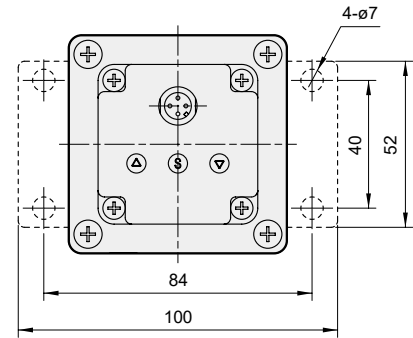



Features



RS-232 manual



RS-485 manual



Caution for safety
(Read before installing)





Feature

- Stepless control of air pressure proportional to an electrical signal.
- Simplify complex pipeline for controlling different pressure.
- MAER310 can be assembled with MA**401/403 series.
- Achieve high precision pressure control with microcomputer PID.
- Maximum flow rate 4000 L/min (Supply pressure 1.0 MPa, Set pressure 0.6 MPa).
- Comply with IP65 and CE certification.

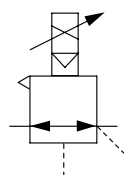
Symbol



Specification

Model		MAER310		
		1K	5K	9K
Pressure range				
Bore No.			8A, 10A, 15A	
Port size			1/4, 3/8, 1/2	
Medium			Air	
Proof pressure		0.3 MPa	1.5 MPa	
Ambient temperature		+5~+50°C (No condensation)		
Min. supply pressure		Set pressure +0.1 MPa		
Max. supply pressure		0.2 MPa	0.7 MPa	1 MPa
Setting pressure range (*1)		0.005~0.1 MPa	0.005~0.5 MPa	0.009~0.9 MPa
Power supply	Connector	M12 plug, 4-pin, A-coded		
	Voltage	DC24V±10%		
	Current	DC24V: 180mA or less		
Precision	Linearity	Within ±1% (F.S.)		
	Hysteresis	Within 0.5% (F.S.)		
	Repeatability	Within ±0.5% (F.S.)		
	Sensitivity	Within 0.2% (F.S.)		
Temperature characteristics		Within ±0.2% (F.S.)/°C		
Output pressure display (*2)	Precision	±2% F.S. ±1 digit		
	Min. unit	MPa:0.001, kgf/cm ² :0.01, bar:0.01, psi:0.1, kPa:1		
Enclosure		IP65		
Accessories of cable with connector		Power: M124A-**  , Communication: M125A-** 		
Weight	Main	740 g		
	Accessories	Bracket: Approx. 86g(B1) , 80g(B2); Power cable with connector: Approx. 130g(3m) Communication cable with connector: Approx. 140g(3m)		

Communication type

Protocol	RS-232	RS-485
Input connector	M12 plug, 5-pin, A-coded	M12 plug, 5-pin, A-coded
Address	1	1~248
Comm. speed	9.6k / 19.2k / 38.4k bps	9.6k / 19.2k / 38.4k bps
Comm. interface	Modbus ASCII	Modbus RTU

*2. Linearity setting and preset pressure setting value both are set by the minimum unit of the output pressure display.

*3. The above characteristics are confined to no flow in the pipeline. When air is consumed on the output side, pressure may become unstable.

*4. The above characteristics apply in a control pressure of 10% to 90% when power voltage is 24 VDC, ambient temperature is 25±3°C, no-loading and working pressure set at the maximum control pressure.

MAER310 Order example & Interface pin

AIR UNIT (ELECTRO – PNEUMATIC REGULATOR)



Order example

MAER310 – 8A – 9K – 10 1 – B1 S3 CS – □

MODEL

PORT SIZE

8A: 1/4
10A: 3/8
15A: 1/2

PRESSURE RANGE

1K: 0.1 MPa (*)
5K: 0.5 MPa
9K: 0.9 MPa

* Made to order.

PRESSURE DISPLAY UNIT

1: MPa
2: kgf/cm²
3: bar
4: psi
5: kPa

POWER CABLE

Blank: Without
S3: Straight 3m
L3: Right angle 3m

PORT THREAD

Blank: Rc thread
G: G thread
NPT: NPT thread

COMMUNICATION MODEL

10: RS-232
20: RS-485

BRACKET

Blank: Without
B1: L type
B2: Flat type

COMMUNICATION CABLE

Blank: Without
CS: Straight 3m
CL: Right angle 3m

Exterior

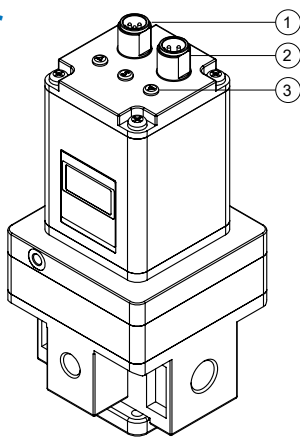

No.	Item	Description
1	Power connector	M12 plug, 4-pin, A-coded (male)
2	Communication connector	M12 plug, 5-pin, A-coded (male)
3	Operation button	Mode settings

Interface pin

RS-232

① Power interface		
Fig	Pin	Signal
	1	24V
	2	-
	3	0V GND
	4	-

② Communication connector		
Fig	Pin	Signal
	1	-
	2	TxD
	3	RxD
	4	GND
	5	-

RS-485

① Power interface		
Fig	Pin	Signal
	1	24V
	2	-
	3	0V GND
	4	-

② Communication connector		
Fig	Pin	Signal
	1	-
	2	B(-)
	3	A(+)
	4	GND
	5	-

MAER310 Capacity

AIR UNIT (ELECTRO – PNEUMATIC REGULATOR)



MAER310-1K

Linearity

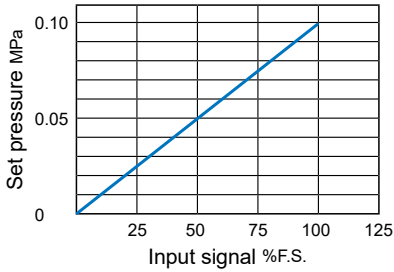

Repeatability

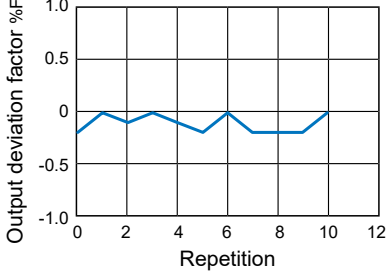

Pressure characteristics

Set pressure 0.05 MPa

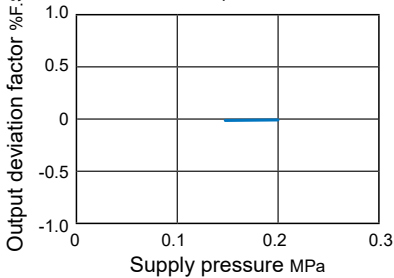

Flow rate characteristics

Supply pressure 0.2 MPa

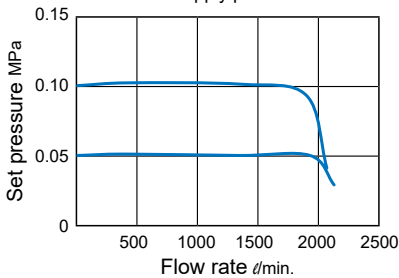

Relief flow characteristics

Back pressure 0.2 MPa

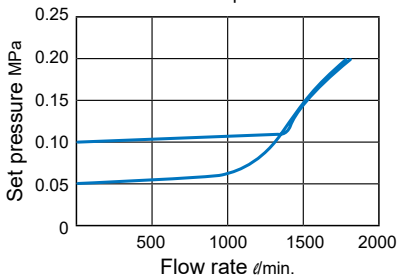

MAER310-5K

Linearity

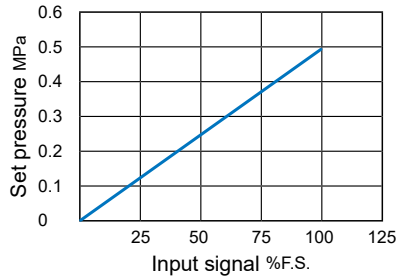

Repeatability

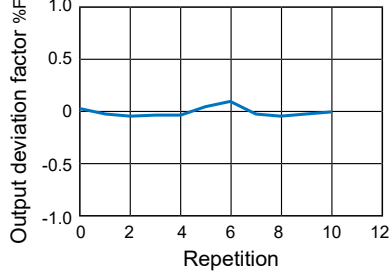

Pressure characteristics

Set pressure 0.2 MPa

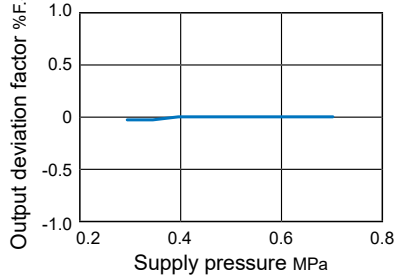

Flow rate characteristics

Supply pressure 0.7 MPa

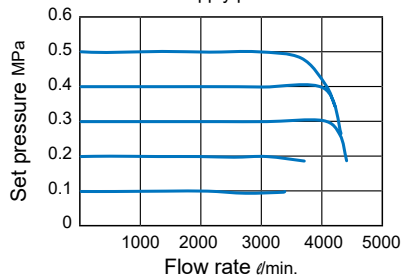

Relief flow characteristics

Back pressure 0.7 MPa

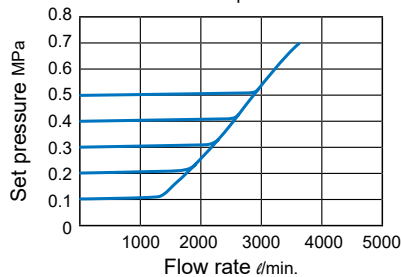

MAER310-9K

Linearity

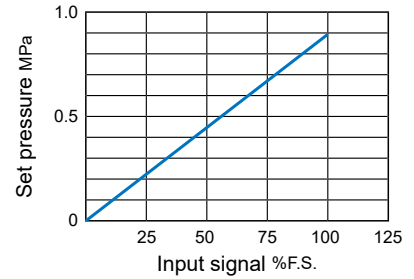

Repeatability

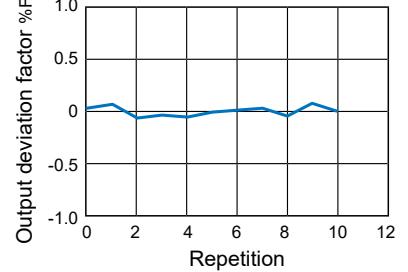

Pressure characteristics

Set pressure 0.4 MPa

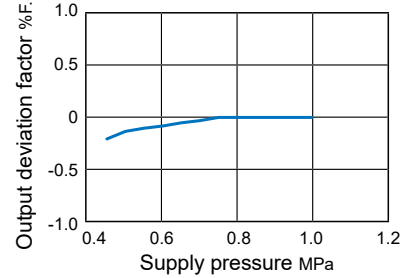

Flow rate characteristics

Supply pressure 1.0 MPa

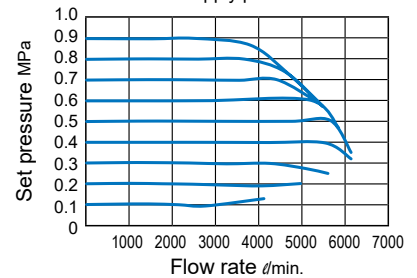

Relief flow characteristics

Back pressure 1.0 MPa

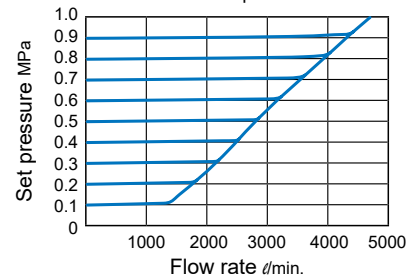

MAER310 Dimensions

AIR UNIT (ELECTRO – PNEUMATIC REGULATOR)



MAER310-* -B1

L type bracket

MAER310-* -B2

Flat type bracket

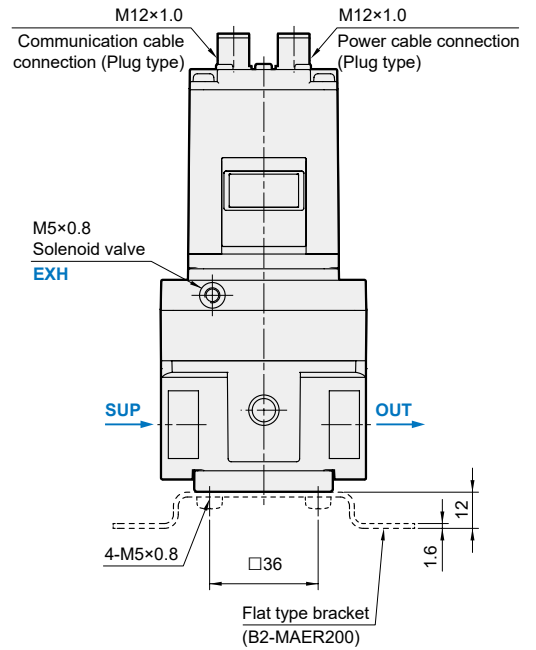
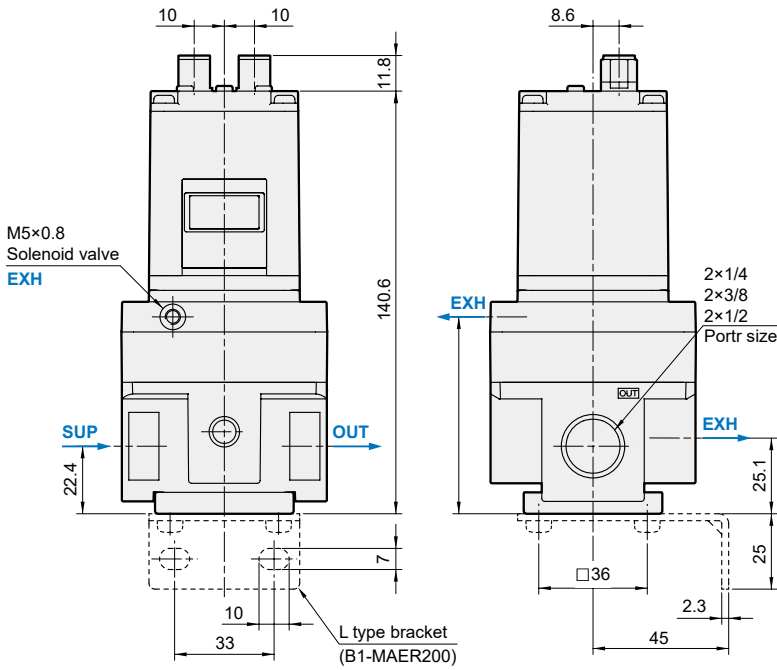
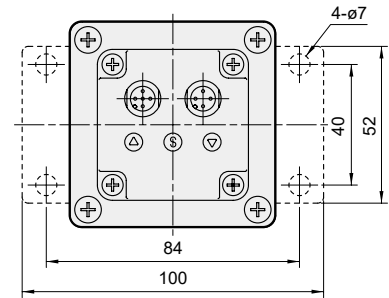
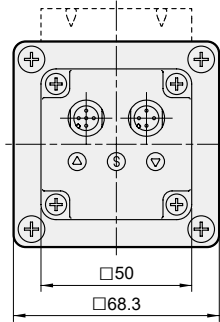

PRECISION REGULATOR MAIR

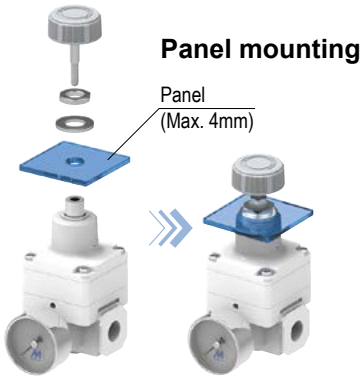

Panel mounting

Panel
(Max. 4mm)

REGULATOR PERFORMANCE

Sensitivity: 0.2% F.S.
Repeatability: $\pm 0.5\%$ F.S.
Set pressure range: 0.005~0.8 MPa

BRACKET

Convenient design, quick mounted bracket, can also be installed on the panel.

COMPATIBLE with MODULAR

MAIR200 can be assembled with MA*302 series.
MAIR300 can be assembled with MA*401/403 series.

STABLE OUTPUT PRESSURE

Compared with the MAR series, low pressure drop problem, better flow characteristics.

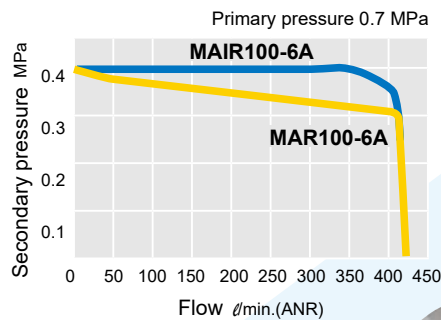

PRESSURE GAUGE

Pressure gauge can be mounted digital pressure switch.

COMPACT & LIGHTWEIGHT

MAIR100 width 35mm, weight 150g
MAIR200 width 50mm, weight 300g
MAIR300 width 68mm, weight 875g



MAIR100

MAIR200

MAIR300

Air Supply

⚠️ Caution

- ❶ If the air supply line contains drain or particulate, etc., the primary pressure fixed throttle can become clogged leading to malfunction, and therefore, be sure to use an air filter (MAF or MAM*) & mist separator.
- ❷ Never use a lubricator on the primary side of the regulator, as this will positively cause the fixed throttle to become clogged and result in a malfunction. If lubrication is required for terminal devices, connect a lubricator on the secondary side.

Maintenance

⚠️ Warning

- ❶ When to be during maintenance, first reduce the precision regulator set pressure to zero, and completely shut off the supply pressure.
- ❷ When a pressure gauge is to be mounted, remove the plug after reducing the regulator pressure set pressure to zero. (Step a→b→c)

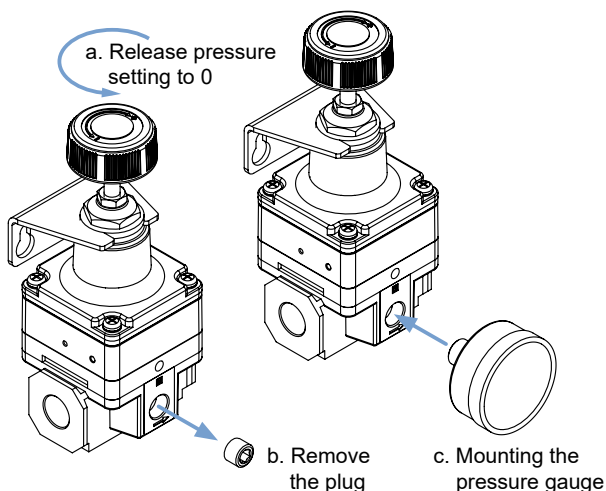

MAIR300 Product Precautions

⚠️ Caution

- ❶ The primary pressure is relatively high (approx. 0.5 MPa or more), the set pressure is low (approx. 0.1 MPa or less), and when operated with the secondary side released to the atmosphere, there may be pulsations in the setting pressure. In this kind of situation, operate with the primary pressure reduced as much as possible, or increase the set pressure somewhat and restrict the secondary side line (add and adjust a stop valve, etc.)
- ❷ When used for the purpose of a relief function, and capacity of the precision regulator is large, the exhaust sound will be loud when being relieved. the operation with a silencer (MSR*) mounted on the exhaust port (EXH port). (Silencer refer to Other Auxiliary Equipment)

Operation

⚠️ Caution

- ❶ Do not use a precision regulator outside the range of its specifications as this can cause failure. (Refer to specifications.)
- ❷ When mounting is performed, make connections while confirming port direction (indications).
- ❸ Screw a panel nut with the proper torque when mounting onto a panel. (be listed as follows)

Model	MAIR100	MAIR200	MAIR300
Torque (kgf)	12.5	21	21

Looseness or faulty sealing will occur if tightening torque is insufficient, while thread damage will result if the torque is excessive.

⚠️ Warning

- ❹ If a directional switching valve (solenoid valve, mechanical valve, etc.) is mounted on the primary side of the the precision regulator and repeatedly switched ON and OFF, wear of the nozzle/diaphragm section will be accelerated and a discrepancy in the setting value may occur. Therefore, avoid using a directional switching valve on the primary side. In the event a directional switching valve will be used, install it on the secondary side of the precision regulator.
- ❺ Air is normally released from the bleed hole (the hole on the side of the body's mid-section). This is a necessary consumption of air based on the construction of the precision regulator, and is not an abnormality.
- ❻ In order to avoid operation mistakes, make sure to tighten the lock nut after pressure adjustment.

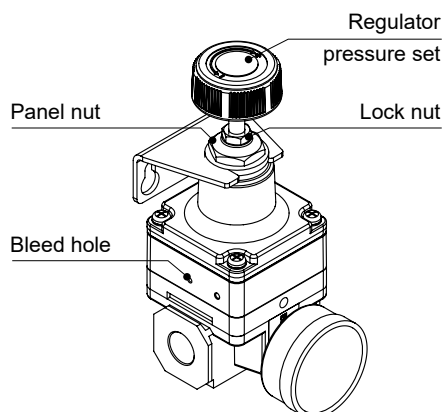

MAIR100 series

AIR UNIT (PRECISION REGULATOR)



Features



Selection table



Caution for safety
(Read before installing)



Symbol

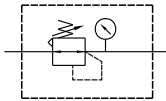

Specification

Model	MAIR100
Bore No.	6A
Port size	1/8
Medium	Air
Max. operating pressure	1 MPa
Min. operating pressure	Setting pressure+0.05 MPa
Proof pressure	1.5 MPa
Regulated pressure range	2K: 0.005~0.2 MPa
	4K: 0.01~0.4 MPa
	8K: 0.01~0.8 MPa
Sensitivity	0.2% F.S.
Repeatability	±0.5% F.S.
Air consumption (*)	4.4 ℓ/min(ANR)
Ambient temperature	- 5~+60°C (No freezing)
Attachment	Bracket
Option	Pressure gauge (PG-33S)
Weight	150 g

Order example

MAIR100 - 6A - 2K - C □ - □

MODEL

PORT SIZE

6A: 1/8

ADJUSTABLE PRESS. RANGE

2K: 0.005~0.2 MPa

4K: 0.01~0.4 MPa

8K: 0.01~0.8 MPa

PRESSURE GAUGE

Blank: without

C: Pressure gauge (PG-33S)

FLOW DIRECTION

Blank: Left to right

R: Right to left

PORT THREAD

Blank: Rc thread

G: G thread

NPT: NPT thread

* For supply pressure 1 MPa.

* Air is normally being discharged to the atmosphere from a bleed hole or an exhaust port.

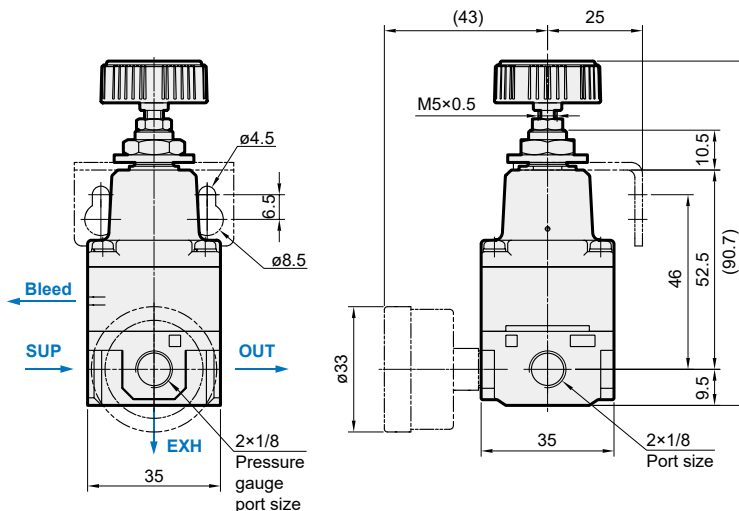
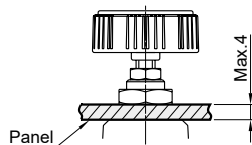
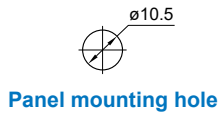
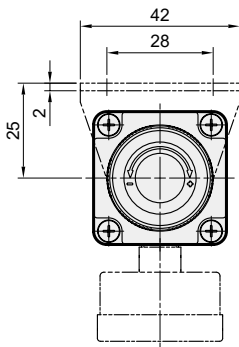

MAIR100 Capacity

AIR UNIT (PRECISION REGULATOR)



Flow feature

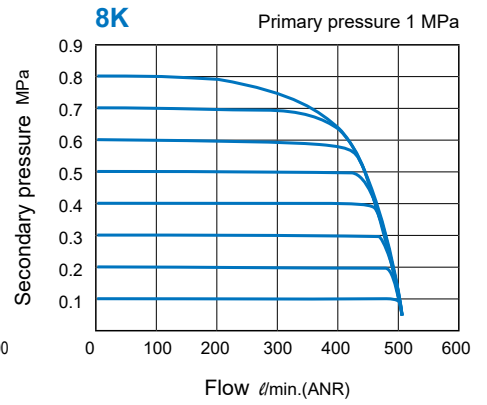
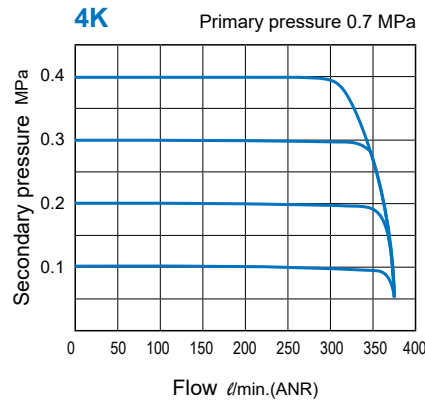
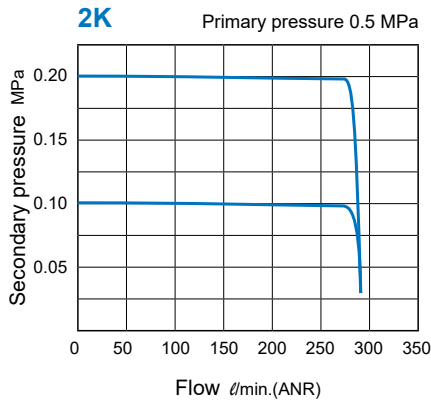

Relief characteristics

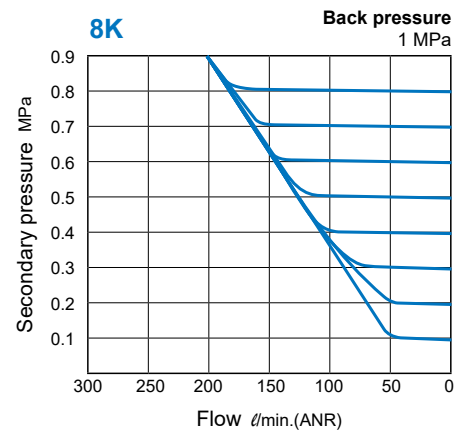
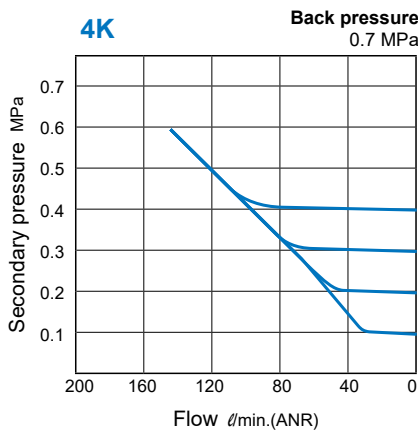
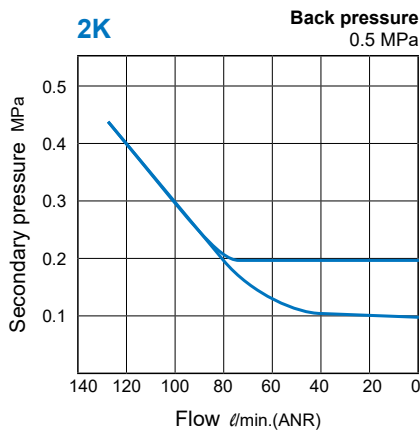

Pressure characteristics

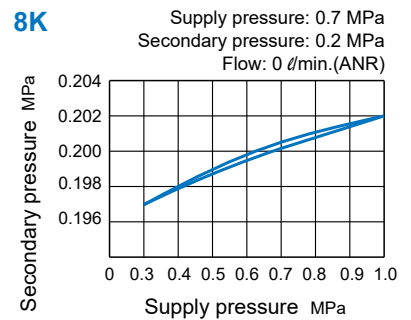
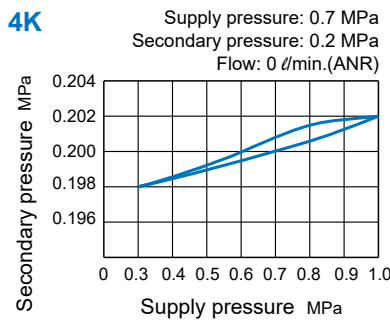
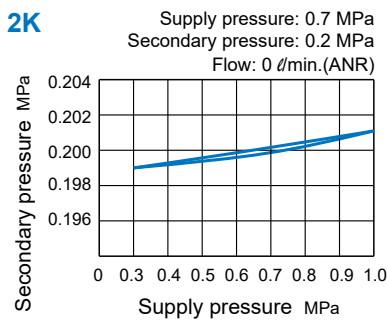

MAIR200 series

AIR UNIT (PRECISION REGULATOR)



Features



Selection table



Caution for safety
(Read before installing)



Symbol

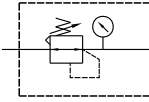

Specification

Model	MAIR200
Bore No.	8A
Port size	1/4
Medium	Air
Max. operating pressure	1 MPa
Min. operating pressure	Setting pressure+0.05 MPa
Proof pressure	1.5 MPa
Regulated pressure range	2K: 0.005~0.2 MPa
	4K: 0.01~0.4 MPa
	8K: 0.01~0.8 MPa
Sensitivity	0.2% F.S.
Repeatability	±0.5% F.S.
Air consumption(*)	4.4 ℓ/min(ANR)
Ambient temperature	- 5~+60°C (No freezing)
Attachment	Bracket
Option	Pressure gauge (PG-40S)
Weight	300 g

Order example

MAIR200 — 8A — 2K — C □ — □

MODEL

PORT SIZE

8A: 1/4

ADJUSTABLE PRESS. RANGE

2K: 0.005~0.2 MPa
4K: 0.01~0.4 MPa
8K: 0.01~0.8 MPa

FLOW DIRECTION

Blank: Left to right
R: Right to left

PORT THREAD

Blank: Rc thread
G: G thread
NPT: NPT thread

PRESSURE GAUGE

Blank: without
C: Pressure gauge (PG-40S)

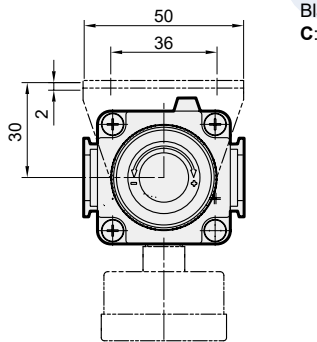

Panel mounting hole

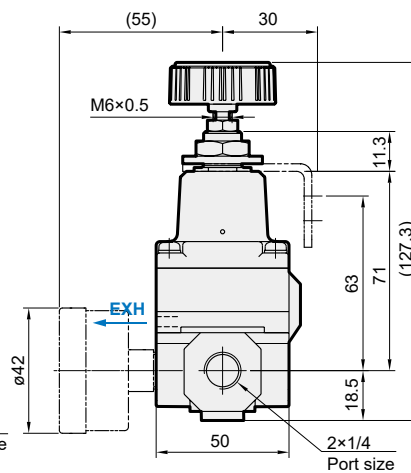
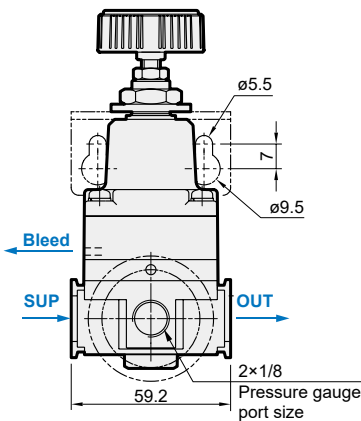
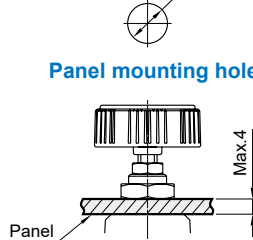

* For supply pressure 1 MPa.

* Air is normally being discharged to the atmosphere from a bleed hole or an exhaust port.

MAIR200 Capacity

AIR UNIT (PRECISION REGULATOR)



Flow feature

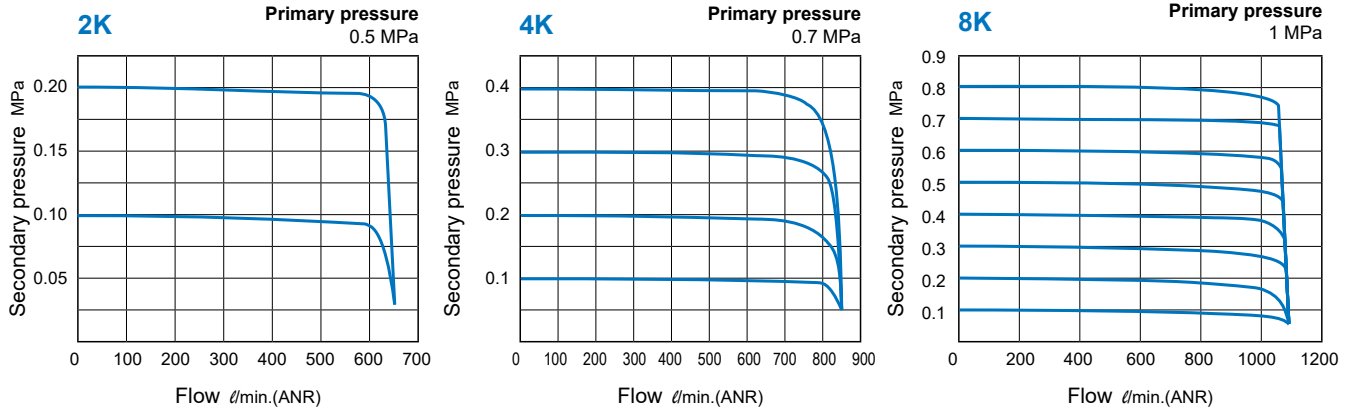

Relief characteristics

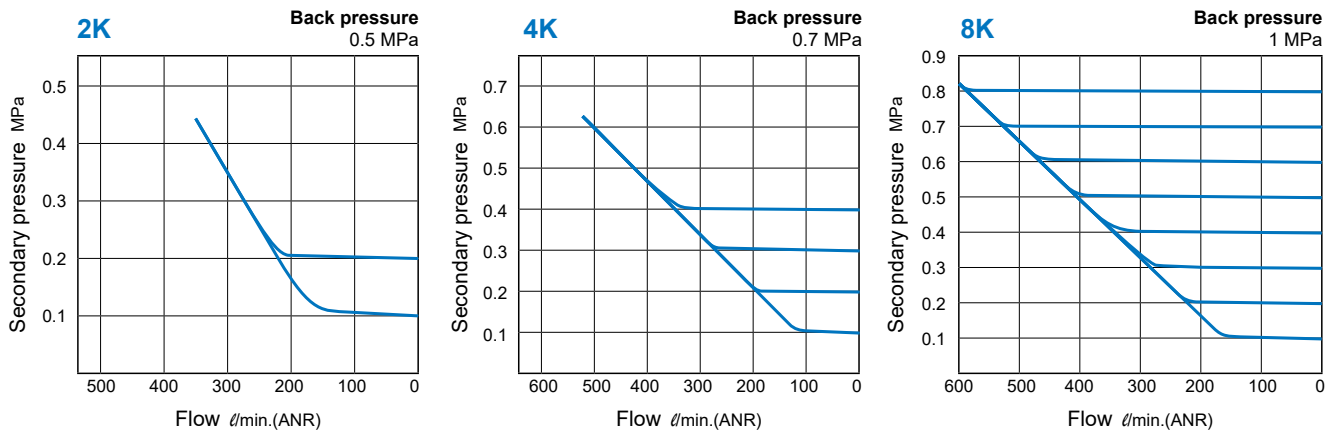

Pressure characteristics

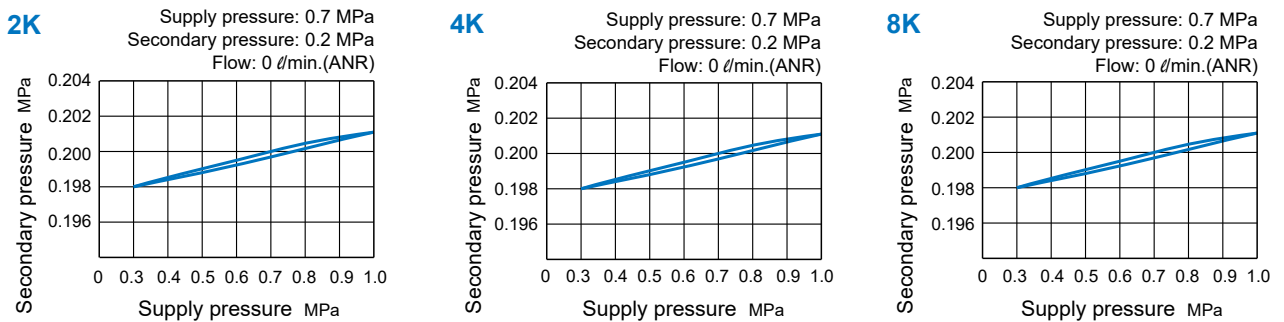

MAIR300 series

AIR UNIT (PRECISION REGULATOR)



mindman



Features



Selection table



Caution for safety
(Read before installing)



Symbol

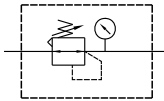

Specification

Model	MAIR300		
Bore No.	8A	10A	15A
Port size	1/4	3/8	1/2
Medium	Air		
Max. operating pressure	1 MPa		
Min. operating pressure	Setting pressure +0.1 MPa		
Proof pressure	1.5 MPa		
Regulated pressure range	2K: 0.005~0.2 MPa		
	4K: 0.01~0.4 MPa		
	8K: 0.01~0.8 MPa		
Sensitivity	0.2h% F.S.		
Repeatability	±0.5% F.S.		
Air consumption (*)	11.5 ℓ/min(ANR)		
Ambient temperature	- 5~+60°C (No freezing)		
Attachment	Bracket		
Option	Pressure gauge (PG-40S)		
Weight	875 g		

Order example

MAIR300 — 8A — 2K — C□ — □

MODEL

PORT SIZE

8A: 1/4
10A: 3/8
15A: 1/2

ADJUSTABLE PRESS. RANGE

2K: 0.005~0.2 MPa
4K: 0.01~0.4 MPa
8K: 0.01~0.8 MPa

FLOW DIRECTION

Blank: Left to right
R: Right to left

PORT THREAD

Blank: Rc thread
G: G thread
NPT: NPT thread

PRESSURE GAUGE

Blank: without
C: Pressure gauge (PG-40S)

* For supply pressure 1 MPa.

* Air is normally being discharged to the atmosphere from a bleed hole or an exhaust port.

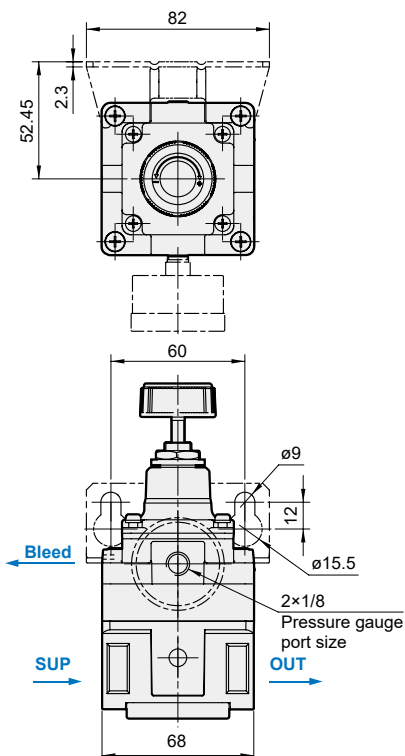

PRESSURE GAUGE
Blank: without
C: Pressure gauge (PG-40S)

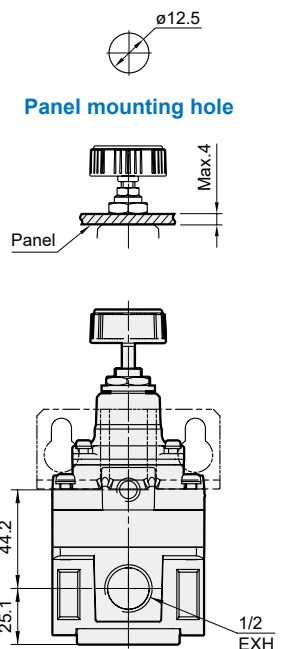

MAIR300 Capacity

AIR UNIT (PRECISION REGULATOR)



Flow feature

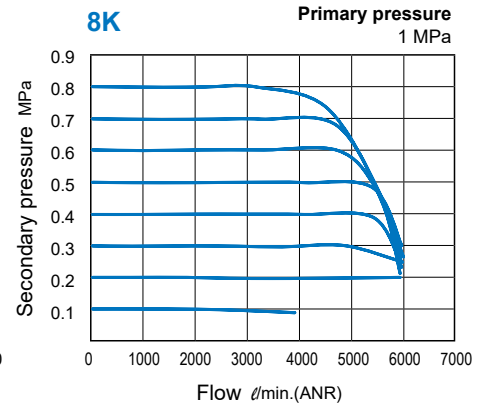
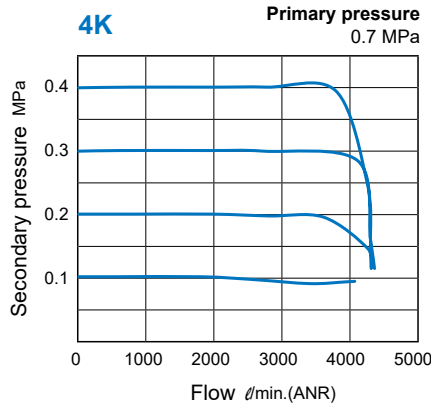
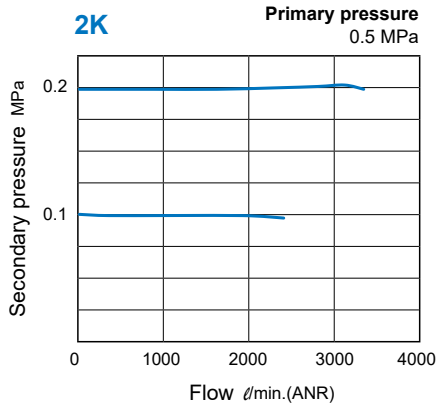

Relief characteristics

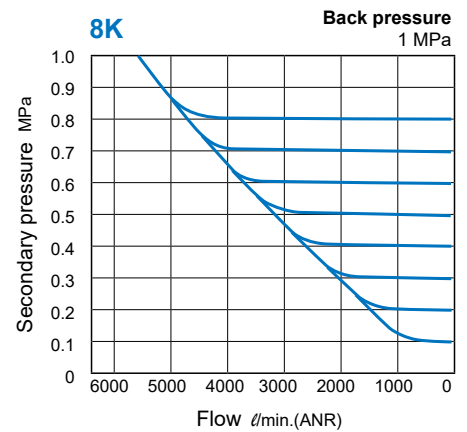
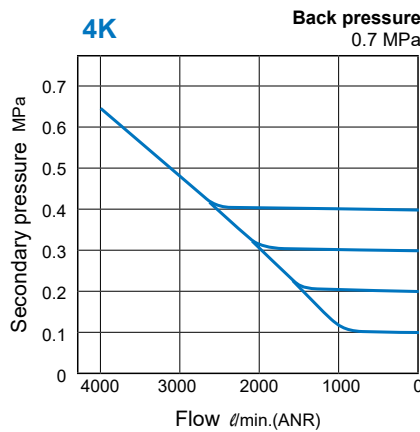
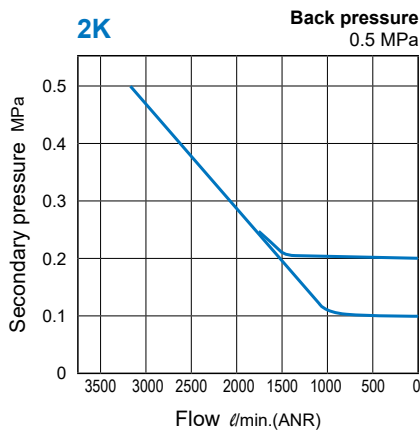

Pressure characteristics

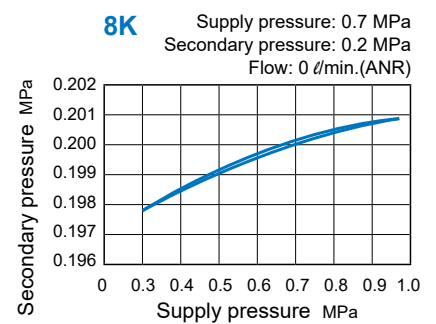
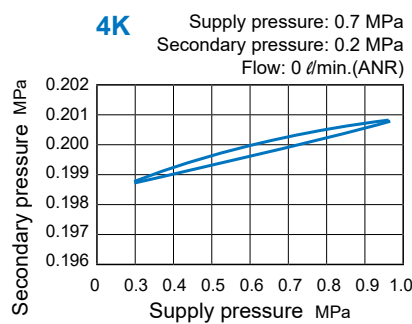
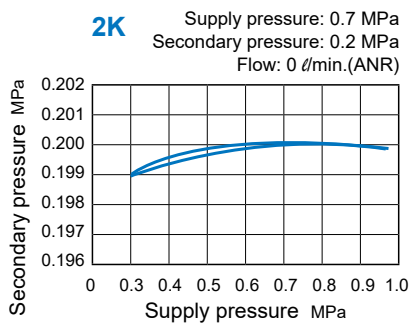

MAL200 series

AIR UNIT (L.UNIT)



Technical data



User manual



Caution for safety
(Read before installing)



Symbol

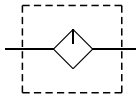

Specification

Model	MAL200	
Bore No.	6A	8A
Port size	1/8	1/4
Medium	Air	
Max. operating pressure	1 MPa	
Proof pressure	1.5 MPa	
Ambient temperature	- 5~+60°C (No freezing)	
Lubricating oil capacity	20 c.c , 35 c.c (MAL200L)	
Min. Flow for oil drip	35 ℓ/min	50 ℓ/min
Recommended lubricating oil	Turbine oil ISO-VG32	
Weight	150 g, 130 g (MAL200L)	

Order example

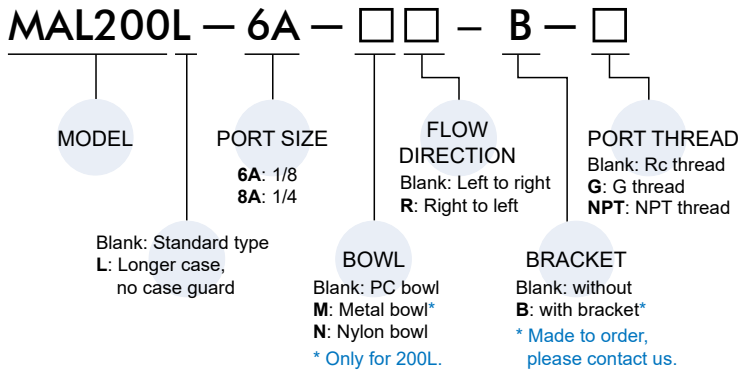

Option accessories

Bracket

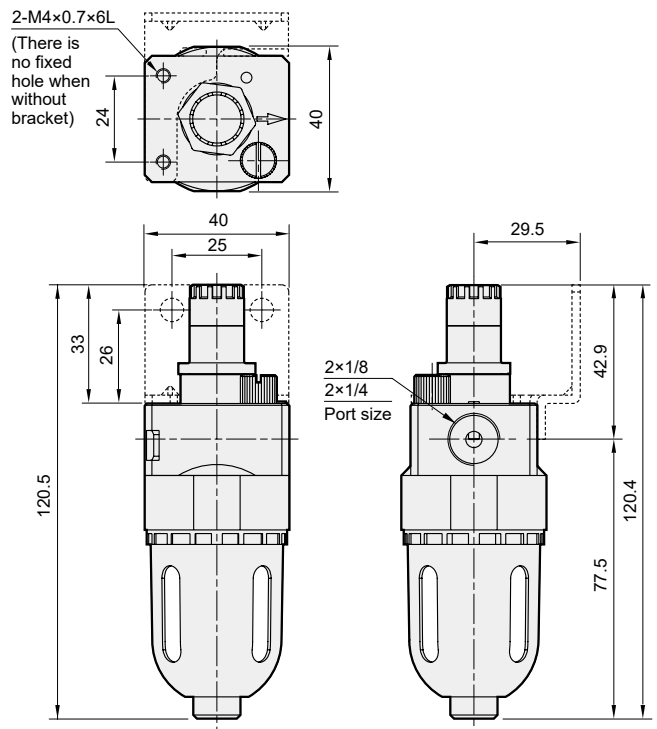
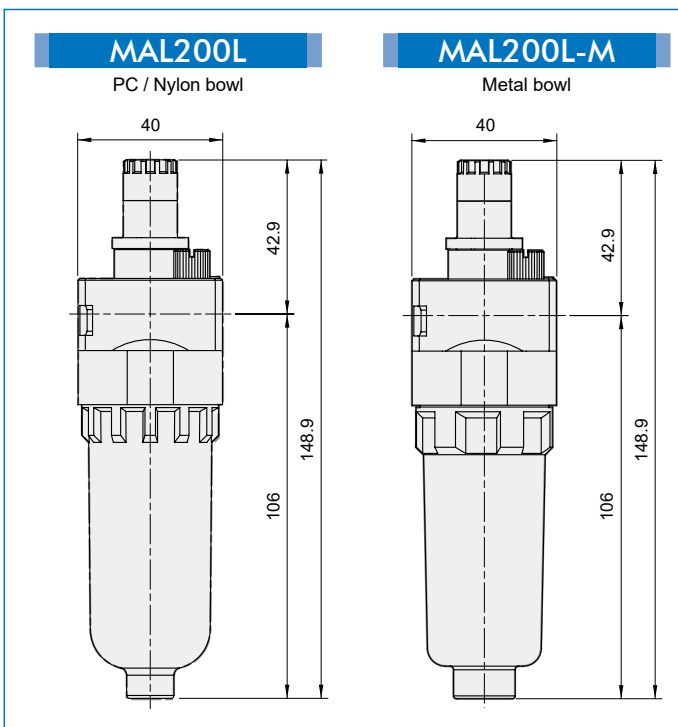
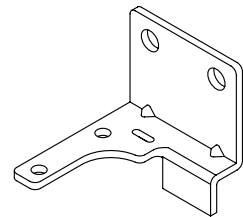

MAL302 series

AIR UNIT (L.UNIT)



Technical data



User manual



Caution for safety
(Read before installing)



Option: **MLF300**

Symbol

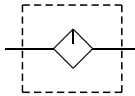

Specification

Model	MAL302		
Bore No.	8A	10A	15A
Port size	1/4	3/8	1/2
Medium	Air		
Max. operating pressure	1 MPa		
Proof pressure	1.5 MPa		
Ambient temperature	- 5~+60°C (No freezing)		
Lubricating oil capacity	65 c.c		
Min. Flow for oil drip	50 ℓ/min	60 ℓ/min	
Recommended lubricating oil	Turbine oil ISO-VG32		
Weight	345 g		

Order example

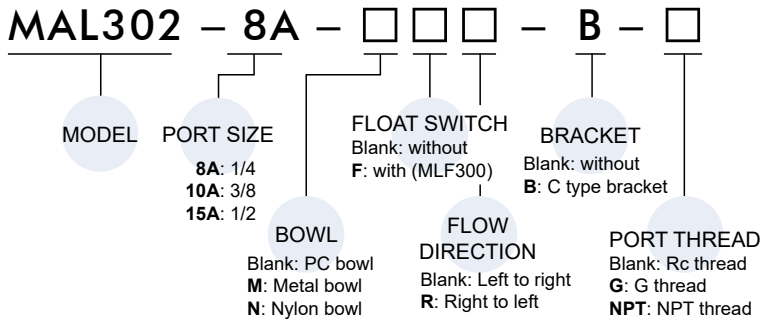

Caution

Metal bowl

Before assembling or disassembling, push the lock plate down to the end, and confirm that is detached from the body then rotate the bowl, otherwise the lock plate will be deformed or the bowl will be scratched.

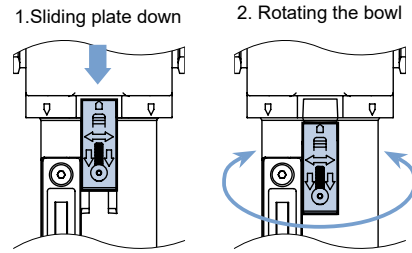

Option ccessories

C type bracket

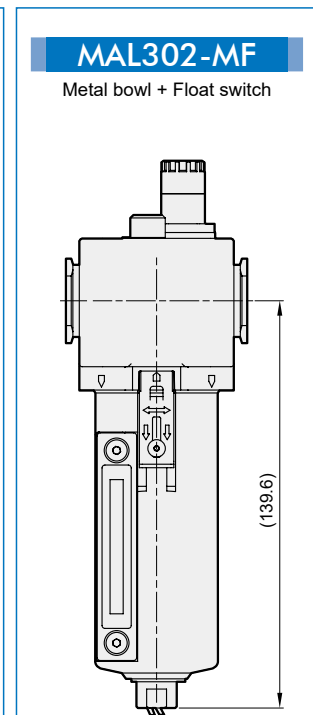
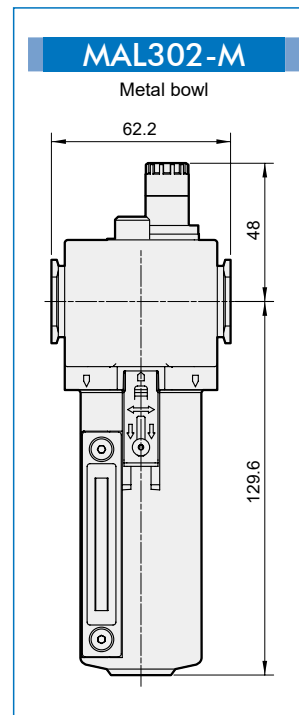
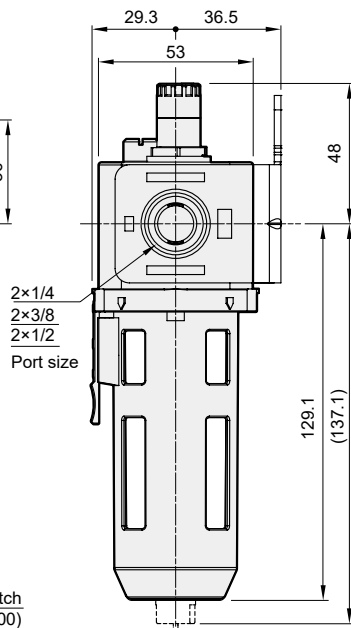
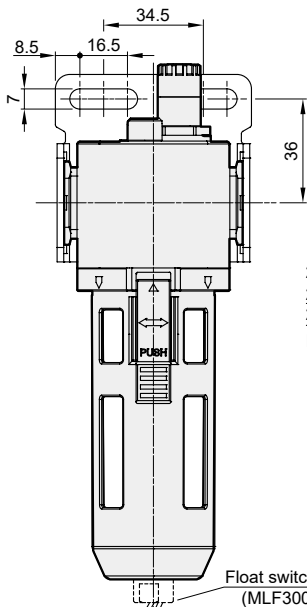
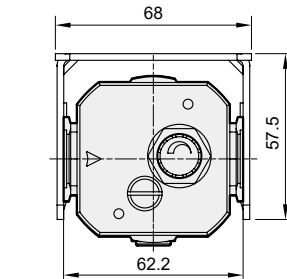
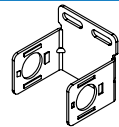

MAL400 series

AIR UNIT (L.UNIT)



Technical data



User manual



Caution for safety
(Read before installing)



Specification

Model	MAL400		
Bore No.	8A	10A	15A
Port size	1/4	3/8	1/2
Medium	Air		
Max. operating pressure	1 MPa		
Proof pressure	1.5 MPa		
Ambient temperature	- 5~+60°C (No freezing)		
Lubricating oil capacity	200 c.c		
Max. flow rate (*) ℓ/min	400	1300	2500
Min. Flow for oil drip	100 ℓ/min	200 ℓ/min	400 ℓ/min
Recommended lubricating oil	Turbine oil ISO-VG32		
Option	Bracket		
Weight	600 g		

Symbol

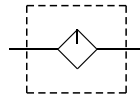

Order example

MAL400 - 8A - □ □ - B - □

MODEL

PORT SIZE

BOWL

BRACKET

PORT THREAD

8A: 1/4
10A: 3/8
15A: 1/2

Blank: PC bowl
N: Nylon bowl

Blank: Without
B: With bracket

Blank: Rc thread
G: G thread
NPT: NPT thread

FLOW

DIRECTION

Blank: Left to right
R: Right to left

* Flow is at pressure P=0.7 MPa with pressure drop ΔP=0.03 MPa. (ANR)

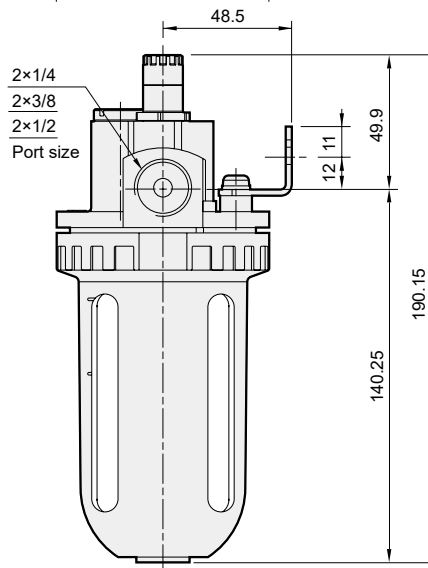
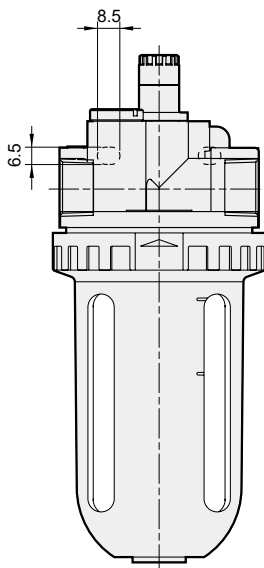
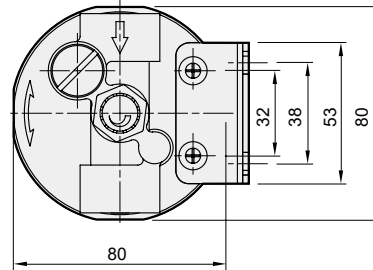

MAL401 series

AIR UNIT (L.UNIT)



Technical data



User manual



Caution for safety
(Read before installing)



Option: **MLF400**

Symbol

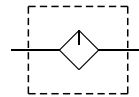

Specification

Model	MAL401		
Bore No.	8A	10A	15A
Port size	1/4	3/8	1/2
Medium	Air		
Max. operating pressure	1.5 MPa		
Proof pressure	2 MPa		
Ambient temperature	- 5~+60°C (No freezing)		
Lubricating oil capacity	200 c.c		
Max. flow rate (*) ℓ/min	1200	2000	2100
Min. Flow for oil drip	30 ℓ/min	65 ℓ/min	80 ℓ/min
Recommended lubricating oil	Turbine oil ISO-VG32		
Weight	545 g		

* Flow is at pressure P=0.7 MPa with pressure drop ΔP=0.03 MPa. (ANR)

Order example

MAL401 - 8A - □ - □ □ - B - □

MODEL

PORT SIZE

8A: 1/4
10A: 3/8
15A: 1/2

FLOAT SWITCH

Blank: without
F: with (MLF400)

BRACKET

Blank: Without
B: C type bracket

EXTERIOR COLOR

Blank: Black & silver
W: Gray & white

FLOW DIRECTION

Blank: Left to right
R: Right to left

PORT THREAD

Blank: Rc thread
G: G thread
NPT: NPT thread

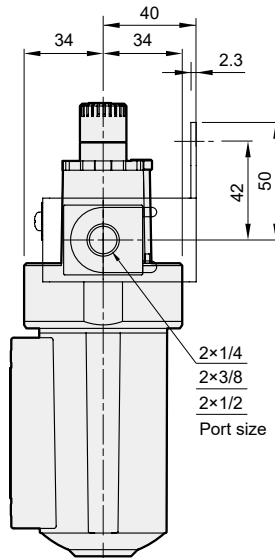
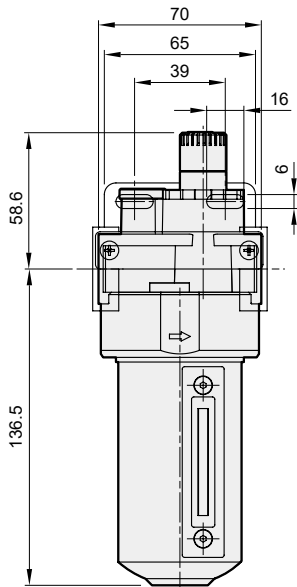
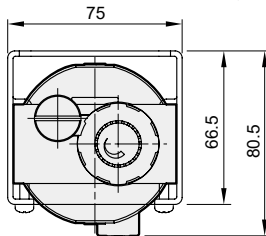

2x1/4
2x3/8
2x1/2
Port size

Option accessories

C type bracket

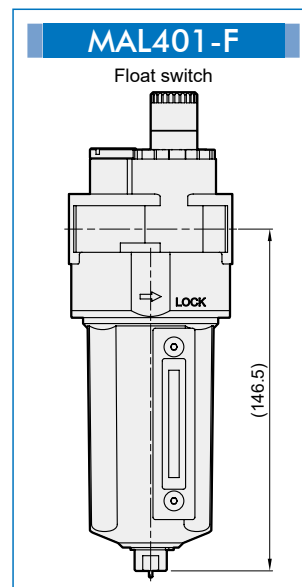
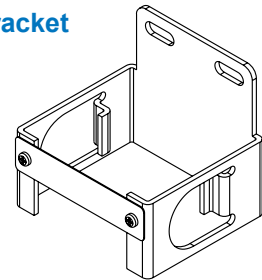

MAL403 series

AIR UNIT (L.UNIT)



Technical data



User manual



Caution for safety
(Read before installing)



Option: MLF400

Symbol

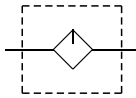

Specification

Model	MAL403		
Bore No.	8A	10A	15A
Port size	1/4	3/8	1/2
Medium	Air		
Max. operating pressure	1 MPa		
Proof pressure	1.5 MPa		
Ambient temperature	- 5~+60°C (No freezing)		
Lubricating oil capacity	200 c.c		
Min. Flow for oil drip	30 ℓ/min	65 ℓ/min	80 ℓ/min
Recommended lubricating oil	Turbine oil ISO-VG32		
Weight	410 g		

Order example

MAL403 - 8A - □ □ □ - B - □

MODEL PORT SIZE

8A: 1/4
10A: 3/8
15A: 1/2

BRACKET

Blank: without
B: C type bracket

PORT THREAD

Blank: Rc thread
G: G thread
NPT: NPT thread

Bowl	Float switch	Flow direction
Blank: PC bowl N: Nylon bowl	Blank: without F: with (MLF400)	Blank: Left to right R: Right to left

Option accessories

C type bracket

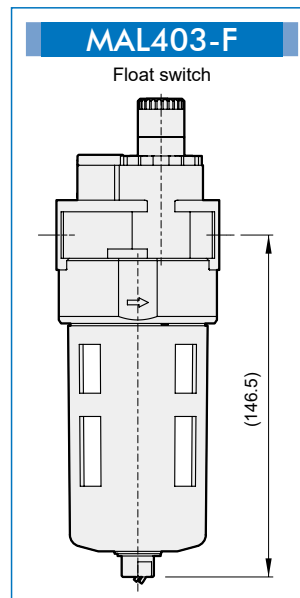
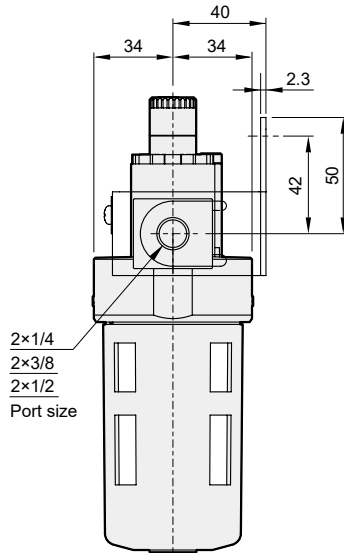
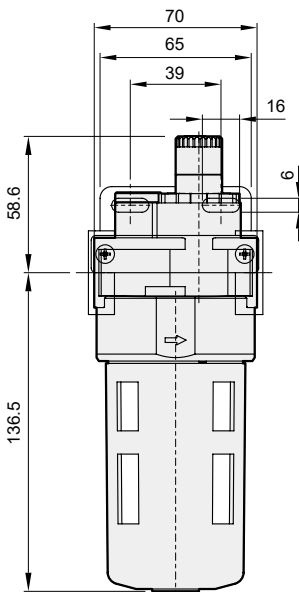
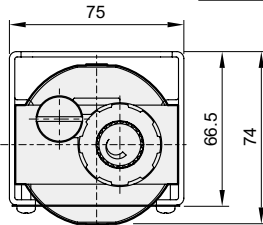
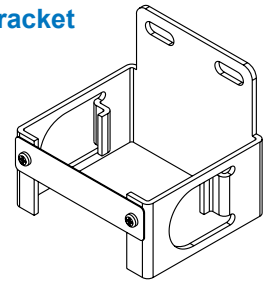

MAL501 series

AIR UNIT (L.UNIT)



Technical data



User manual



Caution for safety
(Read before installing)



Specification

Model	MAL501	
Bore No.	20A	25A
Port size	3/4	1
Medium	Air	
Operating pressure range	PC, Nylon bowl: 0.05~1 MPa	
	Metal bowl: 0.05~1.5 MPa	
Proof pressure	PC, Nylon bowl: 1.5 MPa	
	Metal bowl: 2 MPa	
Ambient temperature	- 5~+60°C (No freezing)	
Lubricating oil capacity	200 c.c	
Min. Flow for oil drip	25 ℓ/min	33 ℓ/min
Recommended lubricating oil	Turbine oil ISO-VG32	
Weight	PC, Nylon bowl: 1260 g	
	Metal bowl: 1380 g	

Symbol

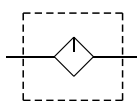

Order example

MAL501 - 20A - □ - □ - B - □

MODEL

PORT SIZE

20A: 3/4
25A: 1

BOWL

Blank: PC bowl
N: Nylon bowl
M: Metal bowl

FLOW DIRECTION

Blank: Left to right
R: Right to left

PORT THREAD

Blank: Rc thread
G: G thread
NPT: NPT thread

BRACKET

Blank: without
B: L type bracket

Option accessories

L type bracket

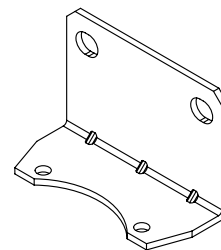

Flow feature

20A Primary pressure 0.7 MPa

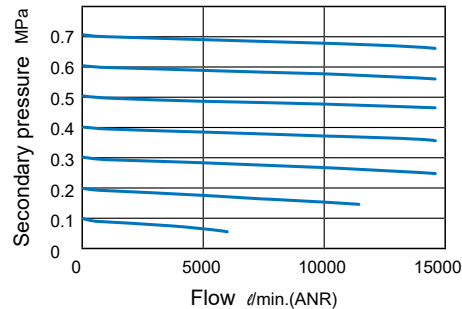

25A Primary pressure 0.7 MPa

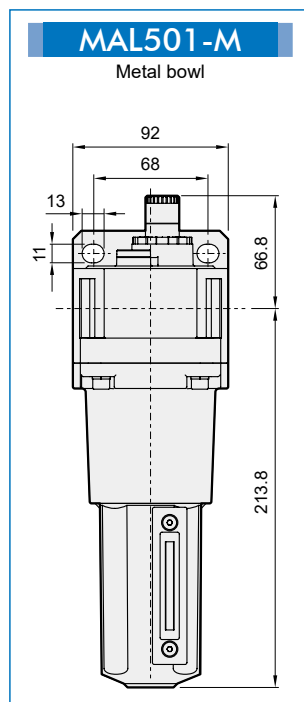
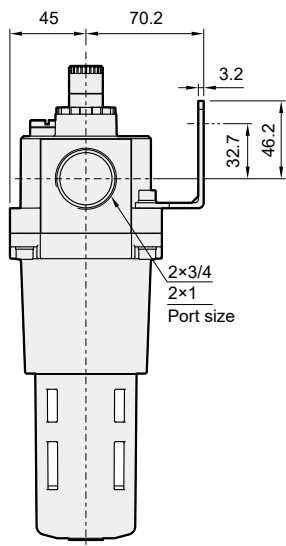
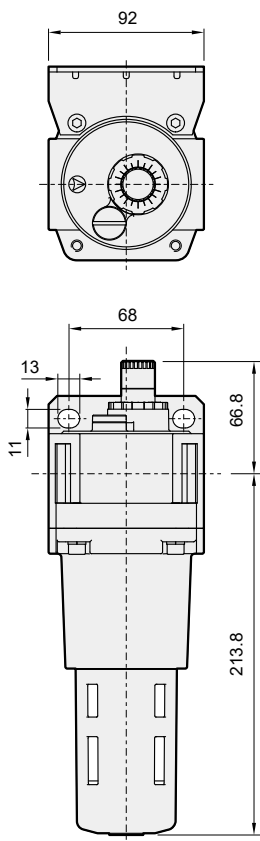
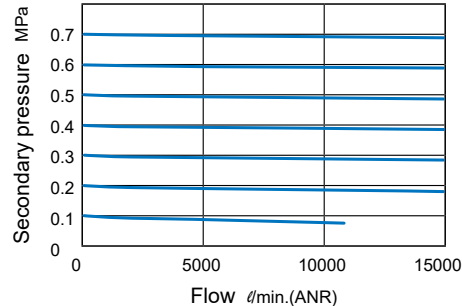



Technical data



User manual



Caution for safety
(Read before installing)



Symbol

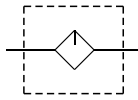

- MAL900 is useful to lubricate air tools, cylinders, valves, air motors and other air driven devices.

Specification

Model	MAL900
Bore No.	40A
Port size	1 1/2
Medium	Air
Max. operating pressure	1.75 MPa
Ambient temperature	0~+80°C (No freezing)
Lubricating oil capacity	1000 c.c
Min. Flow for oil drip	204 ℓ/min
Recommended lubricating oil	Turbine oil ISO-VG32
Standard nominal flow rate (*)	12000 ℓ/min
Weight	1766 g

* Flow is at pressure P=0.6 MPa with pressure drop $\Delta P=0.1$ MPa.

Order example

MAL900 — 40A — □

MODEL

PORT SIZE
40A: 1 1/2

PORT THREAD
Blank: Rc thread
G: G thread
NPT: NPT thread

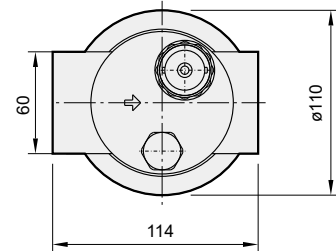

Flow feature

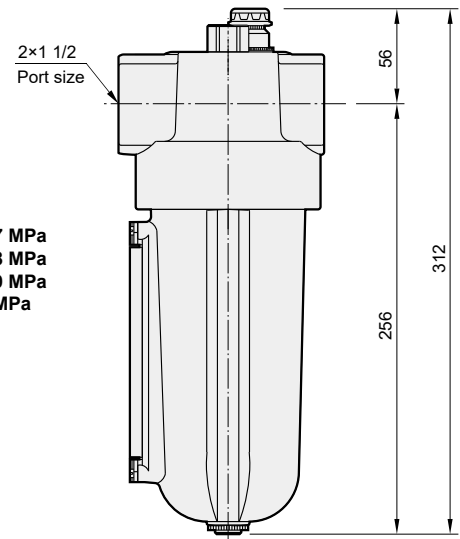
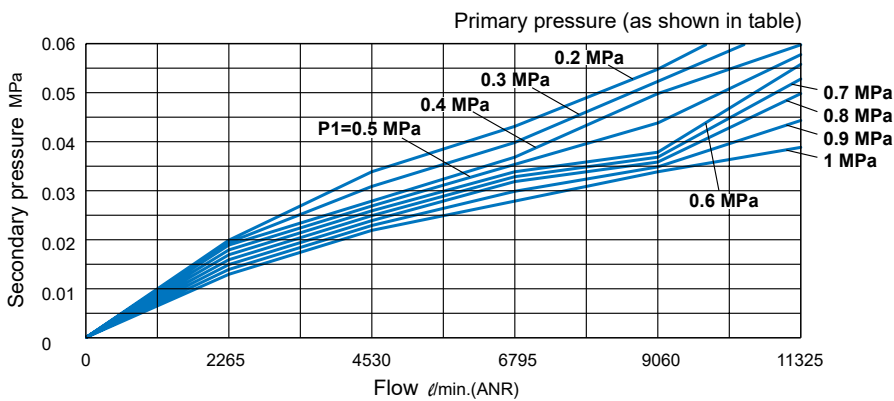

MLF series

FLOAT SWITCH (for L.UNIT)



Selection table



Caution for safety
(Read before installing)



Order example

MLF300 – PP – M8 – 1M

Applicable lubricator		MATERIAL	THREAD SIZE	WIRE LENGTH
300	MAL302-F MAL302-MF	PP	M8	1M: 1000mm
400	MAL401-F MAL403-F			

* For MAL*-F series with "float switch" only.

Specification

Model	MLF300	MLF400
Actuation	Switch turns OFF when float rises (oil level detected), and turns ON when float lowers (no oil level detected)	
Medium	Turbine oil ISO-VG32 (specific gravity: above 0.85)	
Operating pressure (MPa)	Max. 1	
Contact rating (W)	Max. 10	
Switching voltage (VDC)	Max. 90	Max. 200
Switching current (A)	Max. 0.1	Max. 0.5
Electrical termination	Lead wire UL1007 22AWG / PVC wire	Lead wire UL1430 22AWG / PE wire
Weight (g)	14.4	17.35

Model	Bowl set
MLF300	BOWL-MAL302-MF1 BOWL-MAL302-(N)(U)F1
MLF400	BOWL-MAL401(-W)-F1 BOWL-MAL403-(N)(U)F1

MLF300

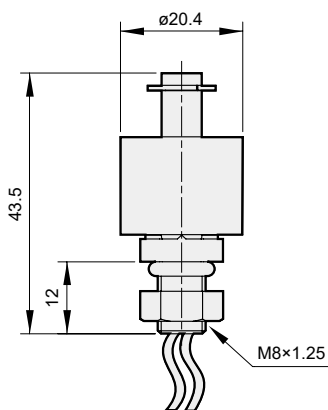

MLF400

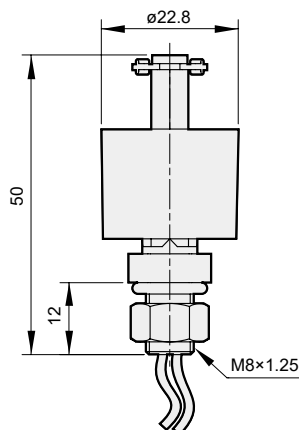

MA*200 / 302 / 401 / 501* series



AIR UNIT (AIR / MIST / MICRO MIST FILTER)

mindman

MAF200D/M MAF200LD/M

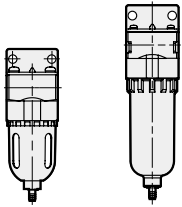

MAF200(L)D

MAF200(L)M

MAF302D

MAF302M

MAF501D

MAF501M

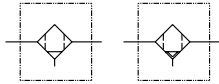

Auto drain

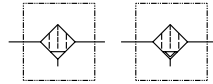

Auto drain

MAF302D/M MAF501D/M

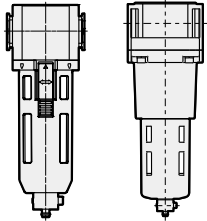

D 0.3 μm Mist filter
M 0.01 μm Micro mist filter

Model	Air filter 5 μm	Mist filter 0.3 μm	Micro mist filter 0.01 μm	Regulator
MAF200(L)D		●		
MAF200(L)M			●	
MAF302D		●		
MAF302M			●	
MAF501D		●		
MAF501M			●	
MAF401A	●			
MAF401D		●		
MAF401M			●	
MAFF401AD	●	●		
MAFF401DM		●	●	
MAFRF401	●	●		●
MATFR401	●	●	●	●

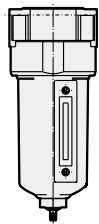

MAF401A

MAF401D

MAF401M

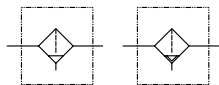

Auto drain

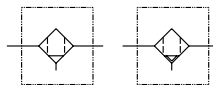

Auto drain

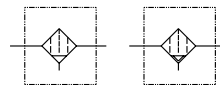

Auto drain

A 5 μm Air filter
D 0.3 μm Mist filter
M 0.01 μm Micro mist filter

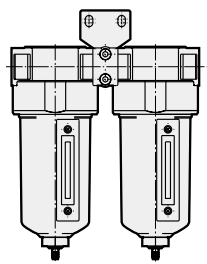

MAFF401AD

MAFF401DM



Auto drain

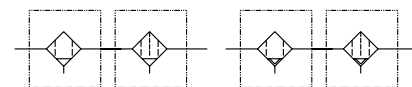

Auto drain

AD 5 μm + 0.3 μm Air filter + Mist filter
DM 0.3 μm + 0.01 μm Mist filter + Micro mist filter

Regulator

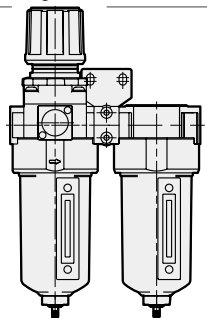

MAFRF401

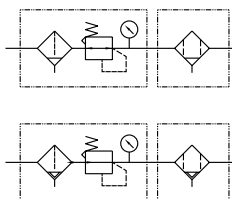

Auto drain

Air filter 5 μm + Mist filter 0.3 μm

Regulator

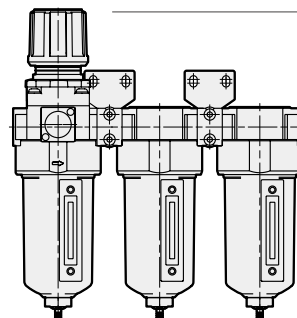

MATFR401

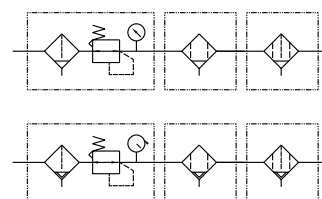

Auto drain

Air filter 5 μm + Mist filter 0.3 μm + Micro mist filter 0.01 μm

MAF200 D / M series

AIR UNIT (MIST / MICRO MIST FILTER)



Selection table



Precision filter



User manual



Caution for safety
(Read before installing)



Symbol

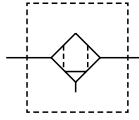

D: 0.3µm

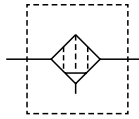

M: 0.01µm

Specification

Model	MAF200D/M	
Bore No.	6A	8A
Port size	1/8	1/4
Medium	Air	
Operating pressure range (*)	0.05~1 MPa	
Proof pressure	1.5 MPa	
Ambient temperature	- 5~+60°C (No freezing)	
Filter element	0.3µm, 0.01µm	
Drain capacity	6.5 cm ³ , 20 cm ³ (MAF200L)	
Weight	187 g, 155 g (MAF200L)	

* Standard unit contains semi-auto-drain function when operating pressure below 0.05 MPa.

Order example

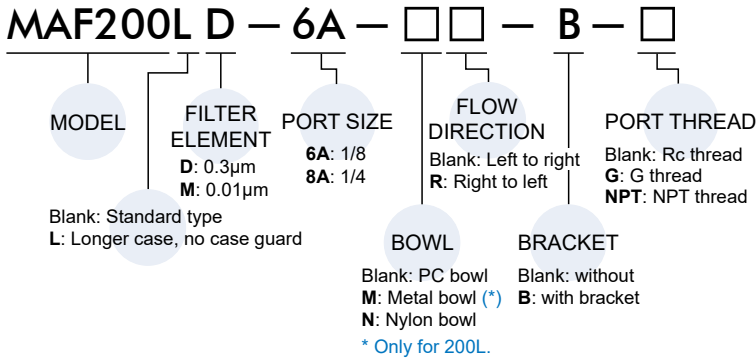

Flow feature

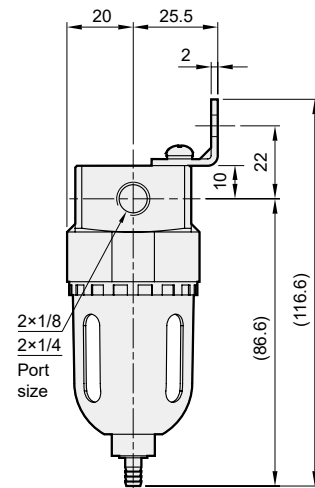
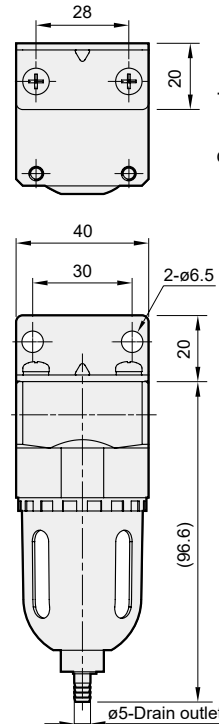
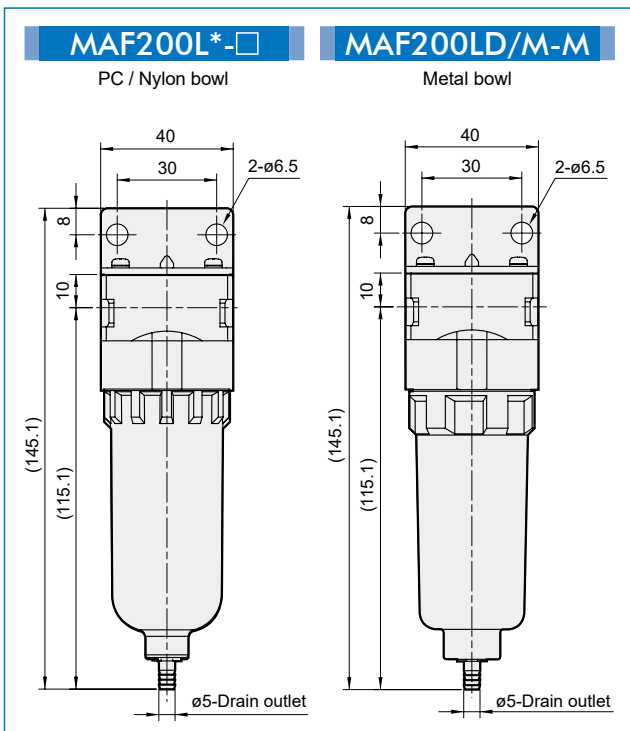
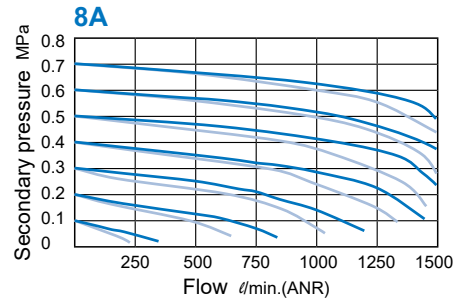
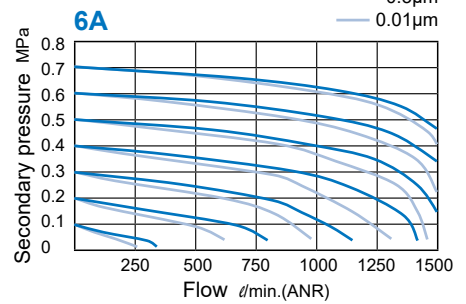

MAF302 D / M series

AIR UNIT (MIST / MICRO MIST FILTER)



Selection table



Precision filter



User manual



Caution for safety
(Read before installing)



Symbol

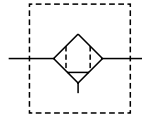

D: 0.3µm

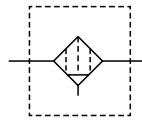

M: 0.01µm

- MA302D is designed for removal of foreign matter as well as oil mist (Element: 0.3µm)
- MA302M is designed for removal of foreign matter as well as oil mist (Element: 0.01µm)

Specification

Model	MAF302D/M		
Bore No.	8A	10A	15A
Port size	1/4	3/8	1/2
Medium	Air		
Operating pressure range (*)	0.05~1 MPa		
Proof pressure	1.5 MPa		
Ambient temperature	- 5~+60°C (No freezing)		
Filter element	0.3 µm, 0.01 µm		
Drain capacity	35 cm ³		
Weight	365 g		

* Standard unit contains semi-auto-drain function when operating pressure below 0.05 MPa.

* Choose auto-drain FMRF300, the pressure range is 0.15~1 MPa.

Order example

MAF302D – 8A – ND□ – B – □

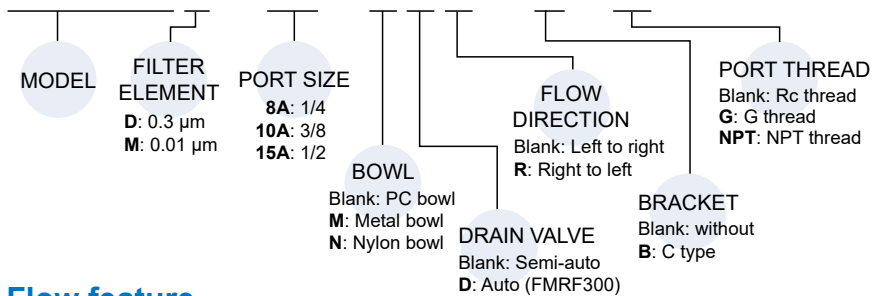

Flow feature

MAF302D (Filter element: 0.3 µm)

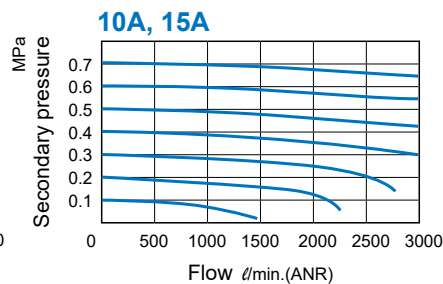
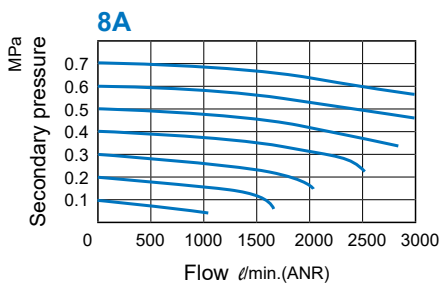

MAF302M (Filter element: 0.01 µm)

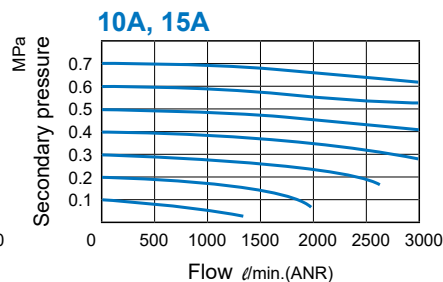
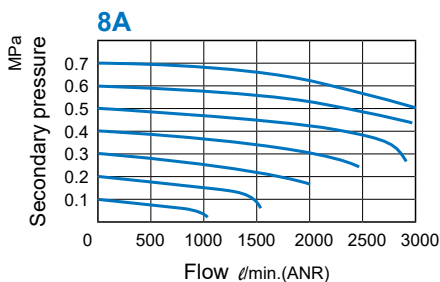

Option accessories

C type bracket

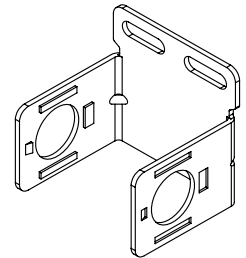

Caution

Metal bowl

Before assembling or disassembling, push the lock plate down to the end, and confirm that is detached from the body then rotate the bowl, otherwise the lock plate will be deformed or the body will be scratched.

1. Sliding plate down
2. Rotating the bowl

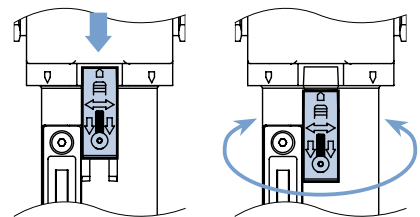

MAF302 D / M Dimensions

AIR UNIT (MIST / MICRO MIST FILTER)



Solenoid Valve

Process Valve

Pilot & Mechanical Valve

Air Treatment Unit

Pressure Switch

Compressed Air Dryer

Auxiliary Equipment

PISCO®

PLC Control System

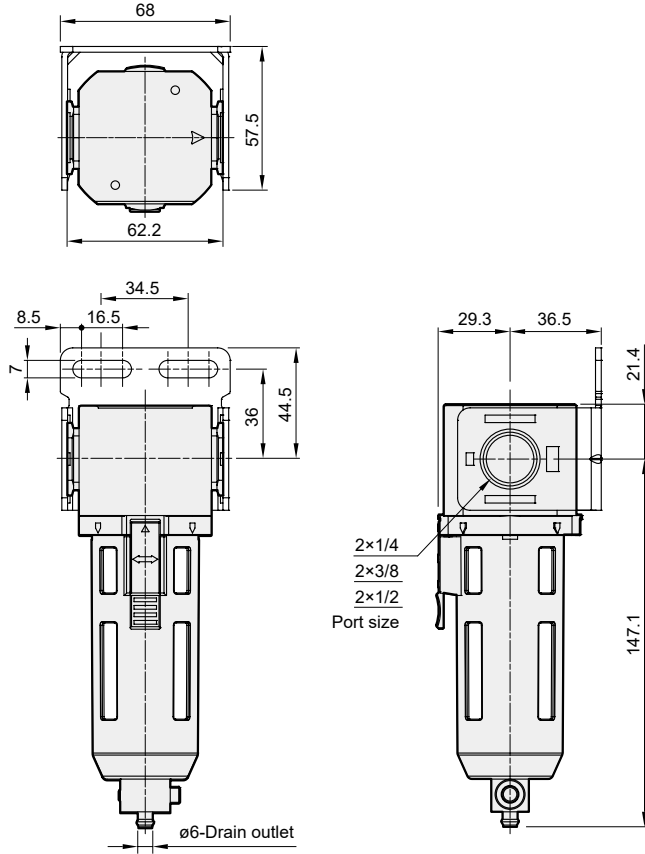

MAF302D/M-D
Auto drain valve

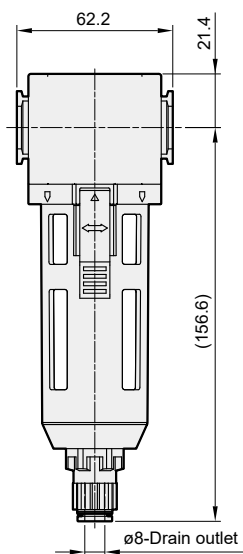

MAF302D/M-M
Metal bowl

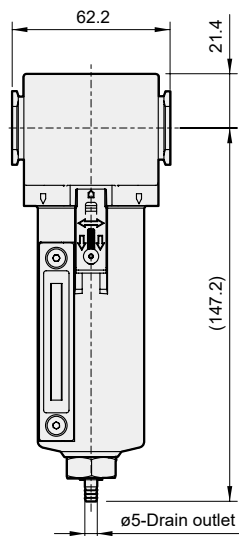

MAF302D/M-MD
Metal bowl + Auto drain valve

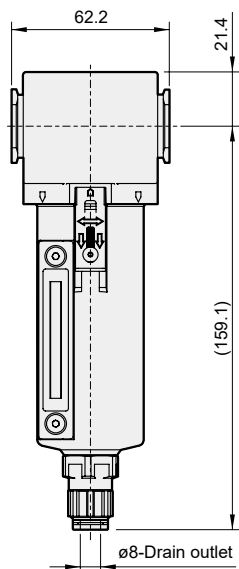

MAF401 A / D / M series

AIR UNIT (AIR / MIST / MICRO MIST FILTER)



Selection table



Precision filter



User manual



Caution for safety
(Read before installing)



Symbol

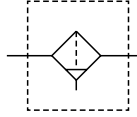

A: 5µm

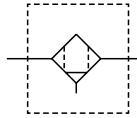

D: 0.3µm

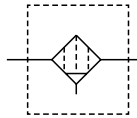

M: 0.01µm

- MAF401A is designed for draining and removal of foreign matter. (Element: 5µm)
- MAF401D/M is designed for removal of foreign matter as well as oil mist (Element: 0.3µm / 0.01µm)

Specification

Model	MAF401A/D/M		
Bore No.	8A	10A	15A
Port size	1/4	3/8	1/2
Medium	Air		
Operating pressure range (*)	0.05~1.5 MPa		
Proof pressure	2 MPa		
Ambient temperature	- 5~+60°C (No freezing)		
Filter element	5 µm, 0.3 µm, 0.01 µm		
Drain capacity	70 cm ³		
Weight	480 g		

* Standard unit contains semi-auto-drain function when operating pressure below 0.05 MPa.

* Choose auto-drain FMRF300, the pressure range is 0.15~1 MPa.

Order example

MAF401D-8A-□-D□-B-□

MODEL

PORT SIZE

8A: 1/4
10A: 3/8
15A: 1/2

DRAIN VALVE

Blank: Semi-auto
D: Auto (FMRF300)

BRACKET

Blank: without
B: C type

FILTER ELEMENT

A: 5 µm
D: 0.3 µm
M: 0.01 µm

EXTERIOR COLOR

Blank: Black & silver
W: Gray & white

FLOW DIRECTION

Blank: Left to right
R: Right to left

PORT THREAD

Blank: Rc thread
G: G thread
NPT: NPT thread

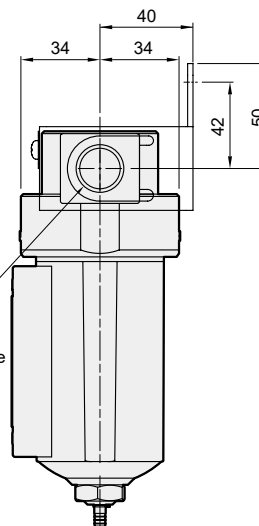
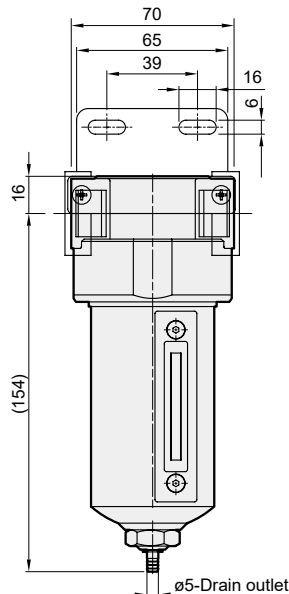
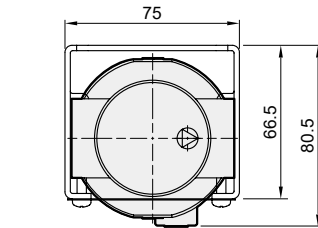

Option accessories

C type bracket

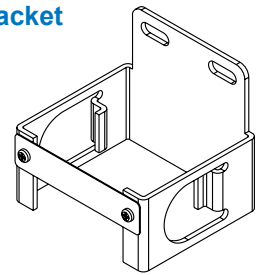

MAF401 A / D / M Capacity

AIR UNIT (AIR / MIST / MICRO MIST FILTER)



Solenoid Valve

Process Valve

Pilot & Mechanical Valve

Air Treatment Unit

Pressure Switch

Compressed Air Dryer

Auxiliary Equipment

PISCO®

PLC Control System

Flow feature

MAF401A (Filter element: 5 μm)

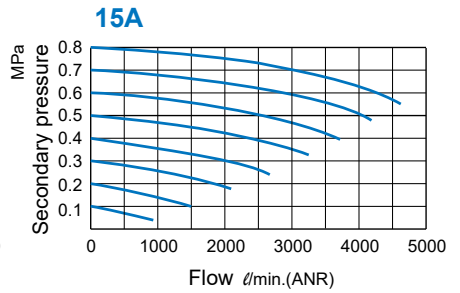
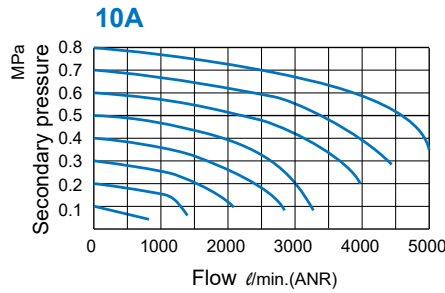
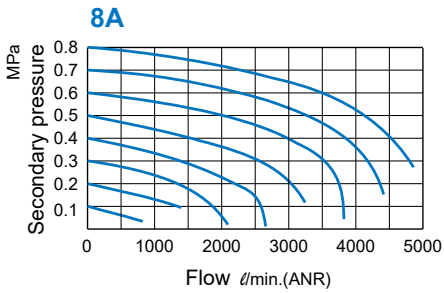

MAF401D (Filter element: 0.3 μm)

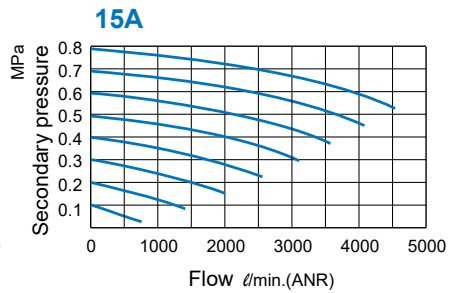
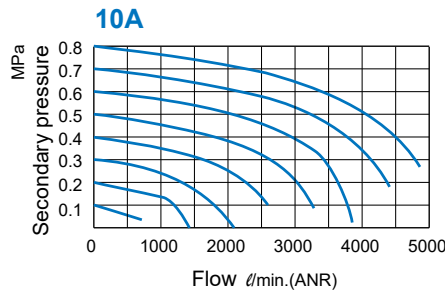
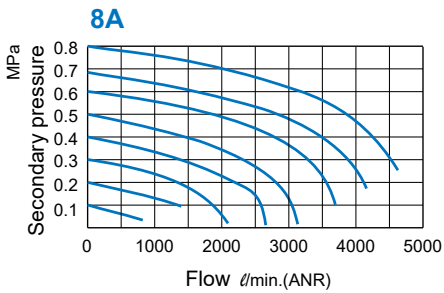

MAF401M (Filter element: 0.01 μm)

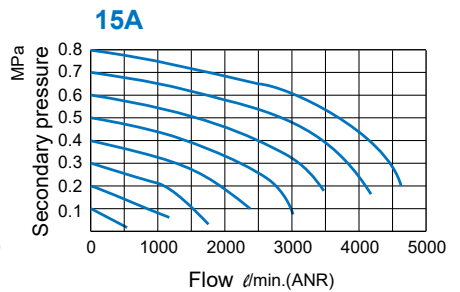
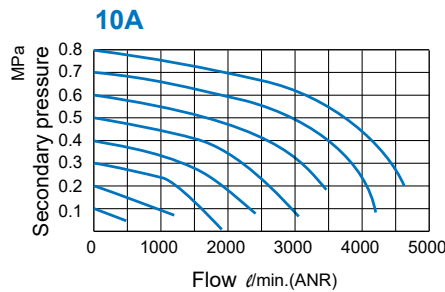
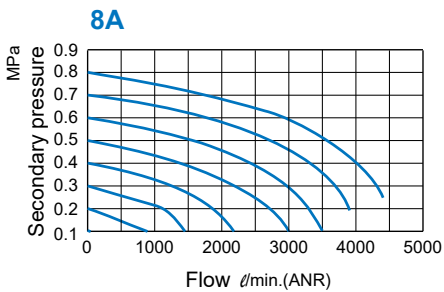

MAFF401 AD / DM series

AIR UNIT (AIR / MIST / MICRO MIST FILTER)



Selection table



Precision filter



User manual



Caution for safety
(Read before installing)



Specification

Model	MAFF401AD	MAFF401DM
Bore No.	8A, 10A, 15A	
Port size	1/4, 3/8, 1/2	
Medium	Air	
Operating pressure range (*)	0.05~1.5 MPa	
Proof pressure	2 MPa	
Ambient temperature	- 5~+60°C (No freezing)	
Filter element	5 μm+0.3 μm	0.3 μm+0.01 μm
Attachment	L type bracket	
Weight	1133 g	

* Standard unit contains semi-auto-drain function when operating pressure below 0.05 MPa.

* Choose auto-drain FMRF300, the pressure range is 0.15~1 MPa.

Symbol

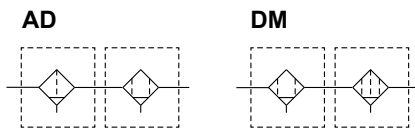

Order example

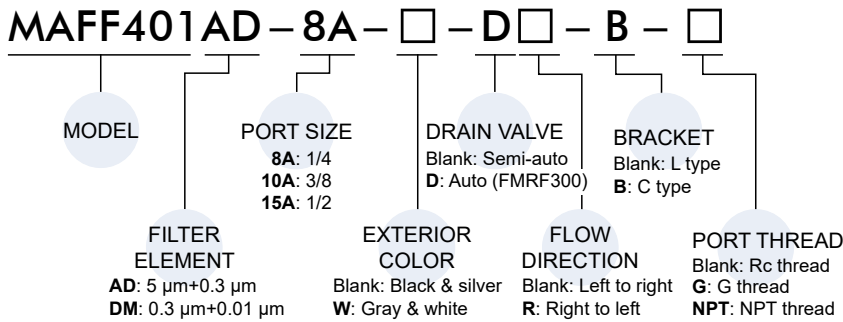

Option accessories

C type bracket

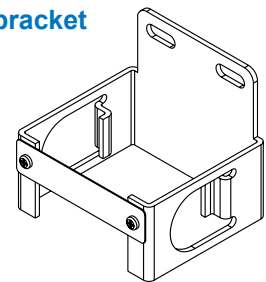

MAFF401**

L type bracket

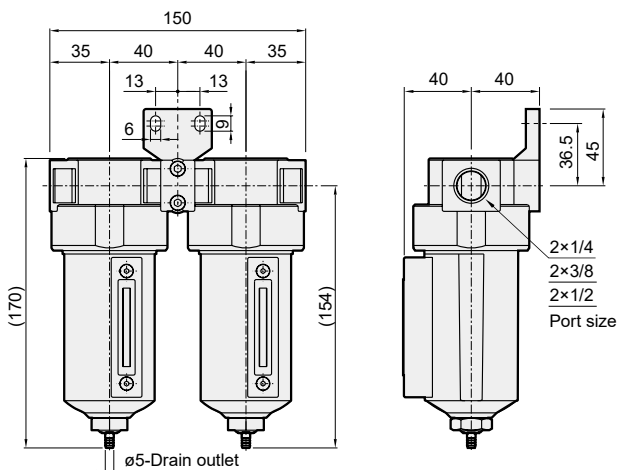

MAFF401**-B

C type bracket

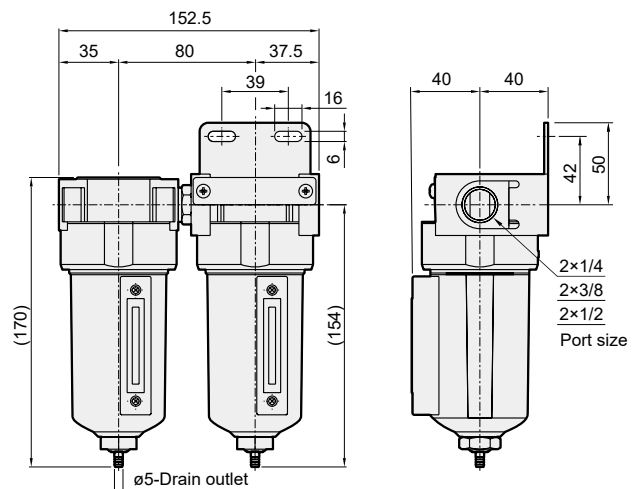

MAFRF401 series

AIR UNIT (F.R.UNIT)



Selection table



Precision filter



User manual



Caution for safety
(Read before installing)



Option: MP41

Specification

Model	MAFRF401		
Bore No.	8A	10A	15A
Port size	1/4	3/8	1/2
Medium	Air		
Operating pressure range (*)	0.05~1.5 MPa		
Proof pressure	2 MPa		
Regulated pressure range	Standard type: 0.1~0.85 MPa		
	High pressure type: 0.1~1.5 MPa		
Ambient temperature	- 5~+60°C (No freezing)		
Filter element	5 μm+0.3 μm		
Attachment	Pressure gauge (PG-20), L type bracket		
Weight	1453 g		

* Standard unit contains semi-auto-drain function when operating pressure below 0.05 MPa.

* Choose auto-drain FMRF300, the pressure range is 0.15~1 MPa.

Symbol

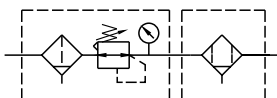

Order example

MAFRF401AD - 8A - □ - HA□□ - E1 - B - □

MODEL

FILTER ELEMENT

AD: 5 μm+0.3 μm

PORT SIZE

8A: 1/4
10A: 3/8
15A: 1/2

EXTERIOR COLOR

Blank: Black & silver
W: Gray & white

PRESSURE SWITCH

Blank: without
E1: MP41P-022
E2: MP41P-022-QD**
E5: MP41P-042
E6: MP41P-042-QD**
** MOQ required.
Please contact us.

PORT THREAD

Blank: Rc thread
G: G thread
NPT: NPT thread

BRACKET

Blank: L type
B: C type

Option accessories

C type bracket

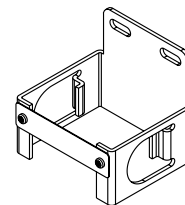

Type	Pressure gauge	Drain valve	Flow direction
Blank: Standard type	Blank: Pressure gauge (PG-20) C: External pressure gauge (PG-40) + Gauge adapter set (A-MAR401) A: Gauge adapter set (A-MAR401)	Blank: Semi-auto D: Auto (FMRF300)	Blank: Left to right R: Right to left
H: High pressure type	C: External pressure gauge (PG-40) + Gauge adapter set (A-MAR401) A: Gauge adapter set (A-MAR401)	Blank: Semi-auto	

* PG-40 (C), A-MAR302 (A) and MP41 (E*) can not be selected at the same time.
* Specification (W) gauge adapter set (A-MAR302).

MAFRF401AD

L type bracket

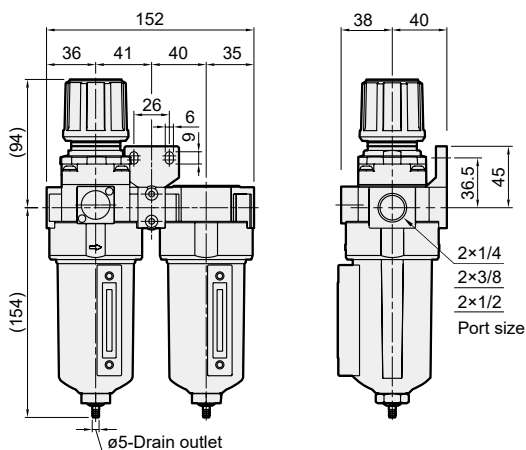

MAFRF401AD-B

C type bracket

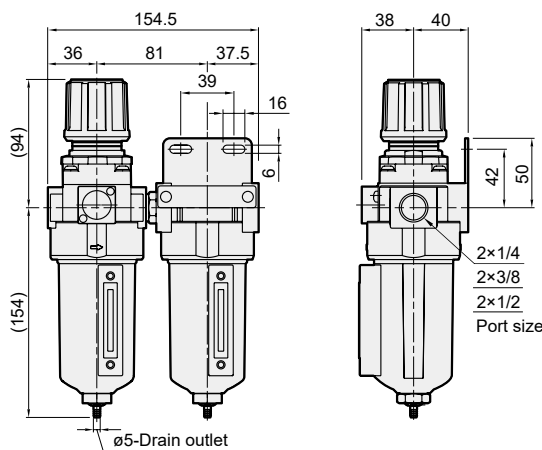

MATFR401 series

AIR UNIT (F.R.UNIT)



Selection table



Precision filter



User manual



Caution for safety
(Read before installing)



Specification

Model	MATFR401		
Bore No.	8A	10A	15A
Port size	1/4	3/8	1/2
Medium	Air		
Operating pressure range (*)	0.05~1.5 MPa		
Proof pressure	2 MPa		
Regulated pressure range	Standard type: 0.1~0.85 MPa		
	High pressure type: 0.1~1.5 Mpa		
Ambient temperature	- 5~+60°C (No freezing)		
Filter element	5 μm+0.3 μm+0.01 μm		
Attachment	Pressure gauge (PG-20), L type bracket		
Weight	2106 g		

* Standard unit contains semi-auto-drain function when operating pressure below 0.05 MPa.

* Choose auto-drain FMRF300, the pressure range is 0.15~1 MPa.

Symbol

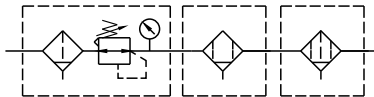

Order example

MATFR401 - 8A - □ - HA□□ - E1 - B - □

MODEL

PORT SIZE

8A: 1/4
10A: 3/8
15A: 1/2

EXTERIOR COLOR

Blank: Black & silver
W: Gray & white

PRESSURE SWITCH

Blank: without
E1: MP41P-022
E2: MP41P-022-QD**
E5: MP41P-042
E6: MP41P-042-QD**

** MOQ required.
Please contact us.

* Refer MP41 series

BRACKET

Blank: L type
B: C type

PORT THREAD

Blank: Rc thread
G: G thread
NPT: NPT thread

Option accessories

C type bracket

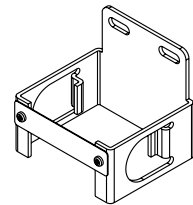

Type	Pressure gauge	Drain valve	Flow direction
Blank: Standard type	Blank: Pressure gauge (PG-20) C: External pressure gauge (PG-40) + Gauge adapter set (A-MAR401) A: Gauge adapter set (A-MAR401)	Blank: Semi-auto D: Auto (FMRF300)	Blank: Left to right R: Right to left
H: High pressure type	C: External pressure gauge (PG-40) + Gauge adapter set (A-MAR401) A: Gauge adapter set (A-MAR401)	Blank: Semi-auto	

* PG-40 (C), A-MAR302 (A) and MP41 (E*) can not be selected at the same time.

* Specification (W) gauge adapter set (A-MAR302).

MATFR401

L type bracket

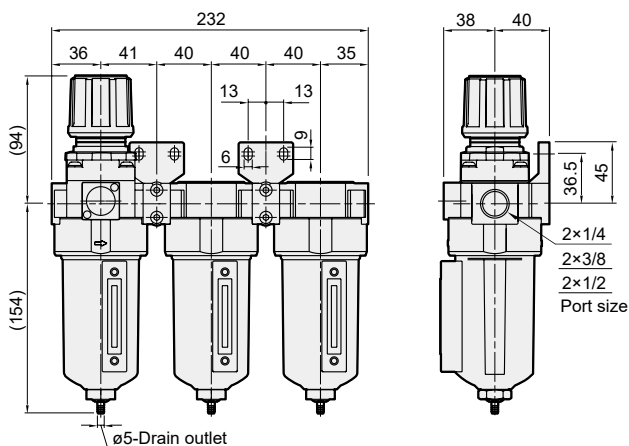

MATFR401-B

C type bracket

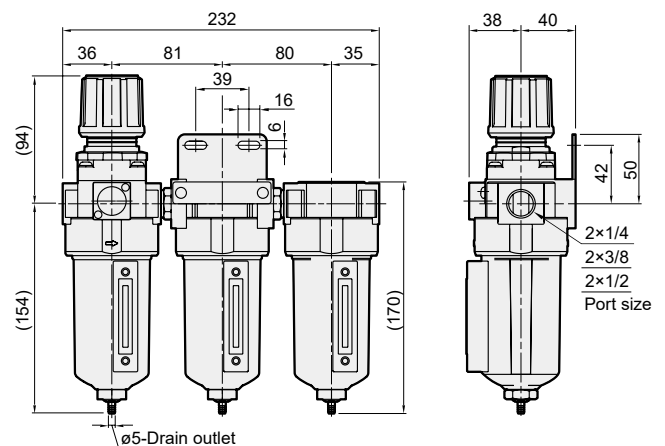

MAF403 A / D / M series

AIR UNIT (AIR / MIST / MICRO MIST FILTER)



Selection table



Precision filter



User manual



Caution for safety
(Read before installing)



Symbol

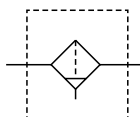

A: 5µm

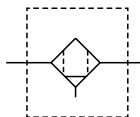

D: 0.3µm

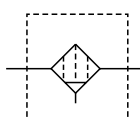

M: 0.01µm

- MAF403A is designed for draining and removal of foreign matter. (Element: 5µm)
- MAF403D/M is designed for removal of foreign matter as well as oil mist (Element: 0.3µm / 0.01µm)

Specification

Model	MAF403A/D/M		
Bore No.	8A	10A	15A
Port size	1/4	3/8	1/2
Medium	Air		
Operating pressure range (*)	0.05~1 MPa		
Proof pressure	1.5 MPa		
Ambient temperature	- 5~+60°C (No freezing)		
Filter element	5 µm, 0.3 µm, 0.01 µm		
Drain capacity	75 cm ³		
Weight	345 g		

* Standard unit contains semi-auto-drain function when operating pressure below 0.05 MPa.

* Choose auto-drain FMRF300, the pressure range is 0.15~1 MPa.

Order example

MAF403 D - 8A - ND □ - B - □

MODEL

PORT SIZE

8A: 1/4
10A: 3/8
15A: 1/2

BOWL

Blank: PC bowl
N: Nylon bowl

FLOW

DIRECTION
Blank: Left to right
R: Right to left

PORT THREAD

Blank: Rc thread
G: G thread
NPT: NPT thread

FILTER ELEMENT

A: 5 µm
D: 0.3 µm
M: 0.01 µm

DRAIN VALVE

Blank: Semi-auto
D: Auto (FMRF300)

BRACKET

Blank: without
B: C type

Option accessories

C type bracket

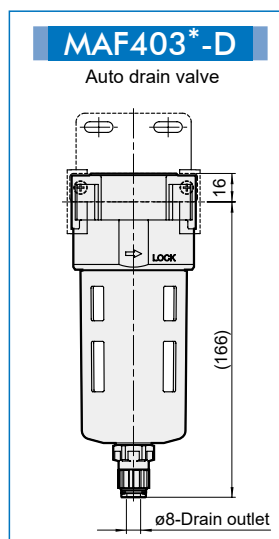
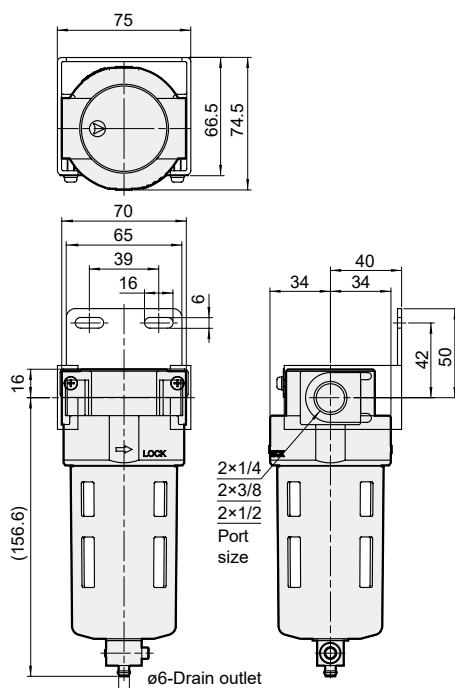
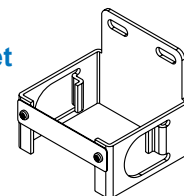

MAF403 A / D / M Capacity

AIR UNIT (AIR / MIST / MICRO MIST FILTER)



Flow feature

MAF403A (Filter element: 5 μm)

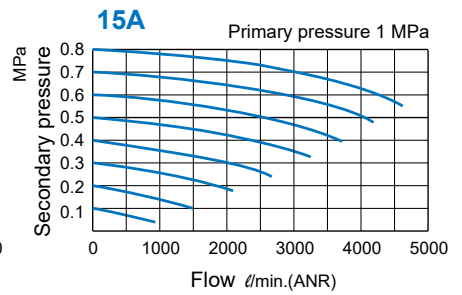
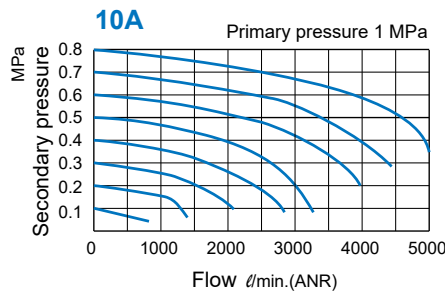
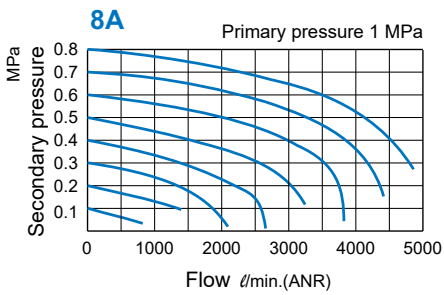

MAF403D (Filter element: 0.3 μm)

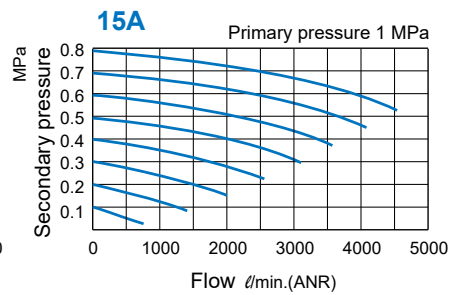
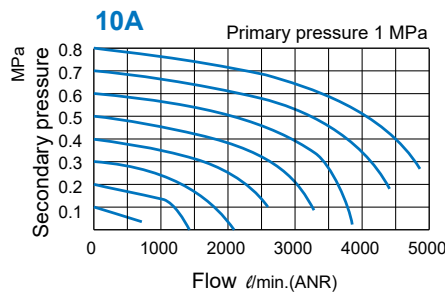
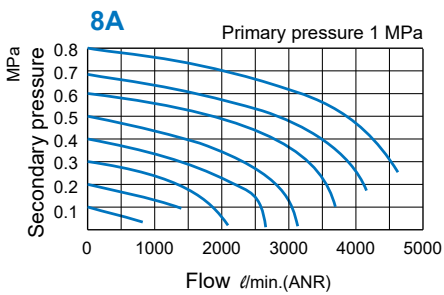

MAF403M (Filter element: 0.01 μm)

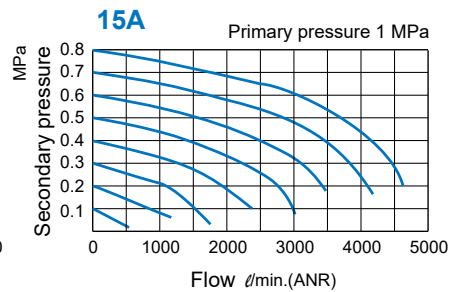
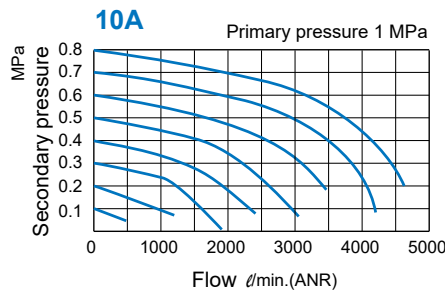
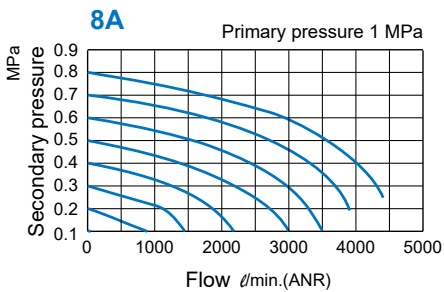

MAF501 D / M series

AIR UNIT (MIST / MICRO MIST FILTER)



Selection table



Precision filter



User manual



Caution for safety
(Read before installing)



Symbol

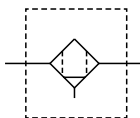

D: 0.3 μ m

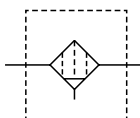

M: 0.01 μ m

Specification

Model	MAF501D/M	
Bore No.	20A	25A
Port size	3/4	1
Medium	Air	
Operating pressure range (*)	Nylon bowl, PC bowl: 0.05~1 MPa	
	Metal bowl: 0.05~1.5 MPa	
Proof pressure	Nylon bowl, PC bowl: 1.5 MPa	
	Metal bowl: 2 MPa	
Ambient temperature	- 5~+60°C (No freezing)	
Filter element	0.3 μ m, 0.01 μ m	
Drain capacity	Nylon bowl, PC bowl: 75 cm ³	
	Metal bowl: 70 cm ³	
Weight	Nylon bowl, PC bowl: 1180g	
	Metal bowl: 1300g	

* Standard unit contains semi-auto-drain function when operating pressure below 0.05 MPa.

* Choose auto-drain FMRF300, the pressure range is 0.15~1 MPa.

* Replace filter element at least once per year or when pressure drop reaches 0.07 MPa.

Order example

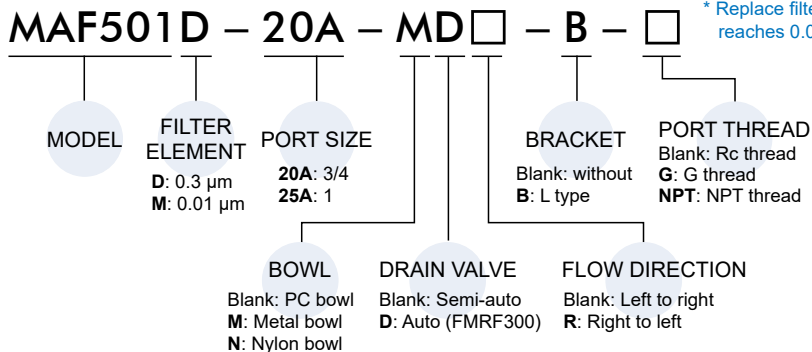

Option accessories

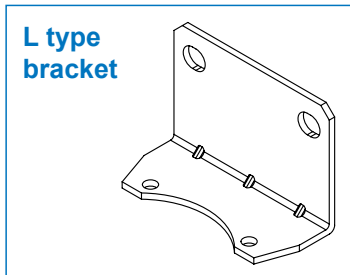

Flow feature

MAF501D (Filter element: 0.3 μ m)

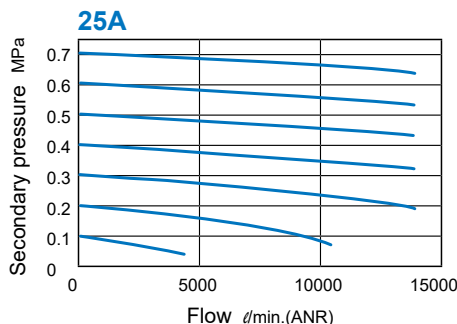
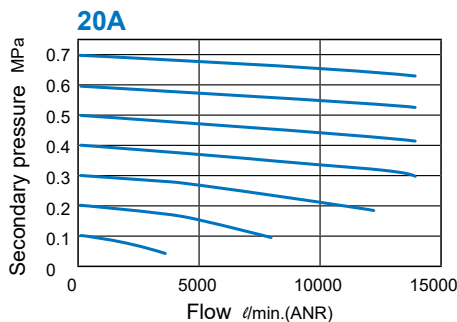

MAF501M (Filter element: 0.01 μ m)

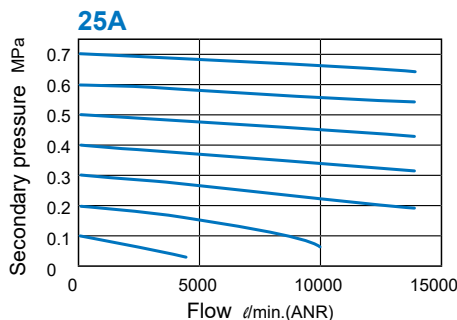
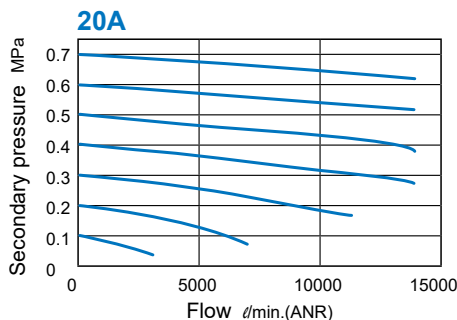

MAF501 D / M Dimensions

AIR UNIT (MIST / MICRO MIST FILTER)



mindman

MAF501D/M-D

Auto drain valve

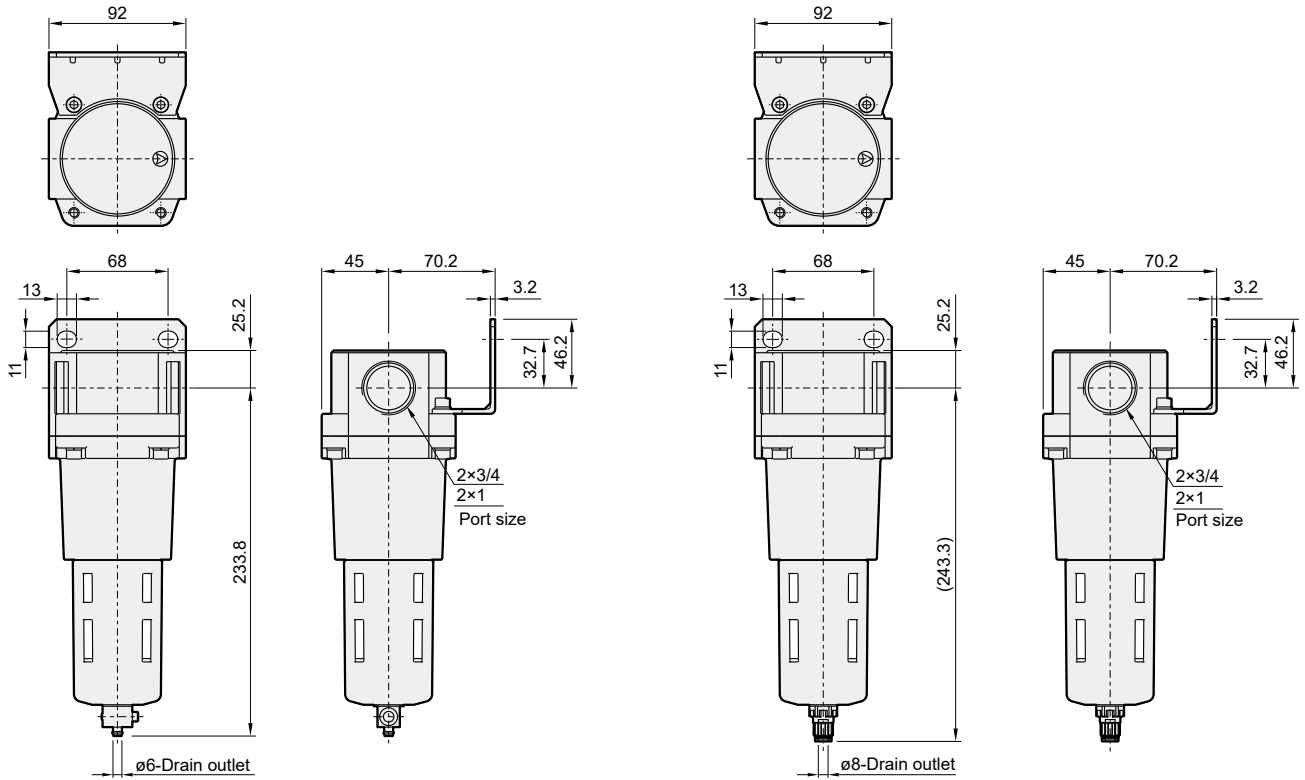

MAF501D/M-M

Metal bowl

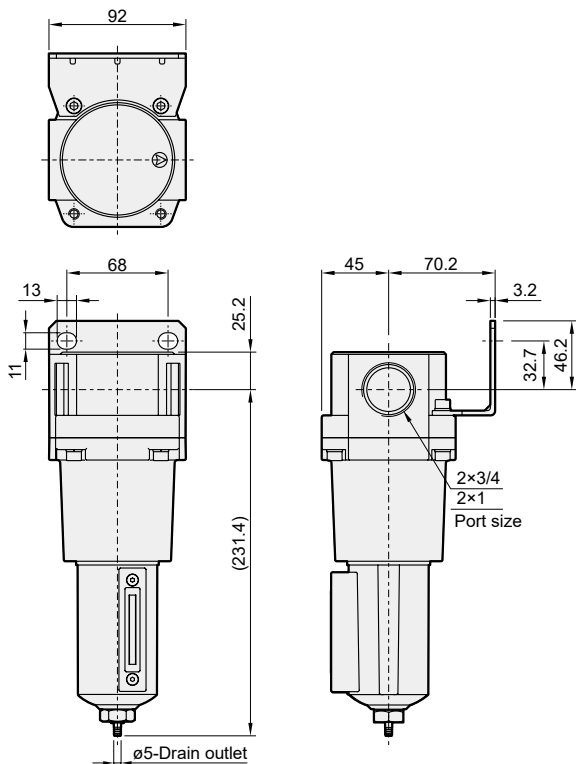

MAF501D/M-MD

Metal bowl + auto drain valve

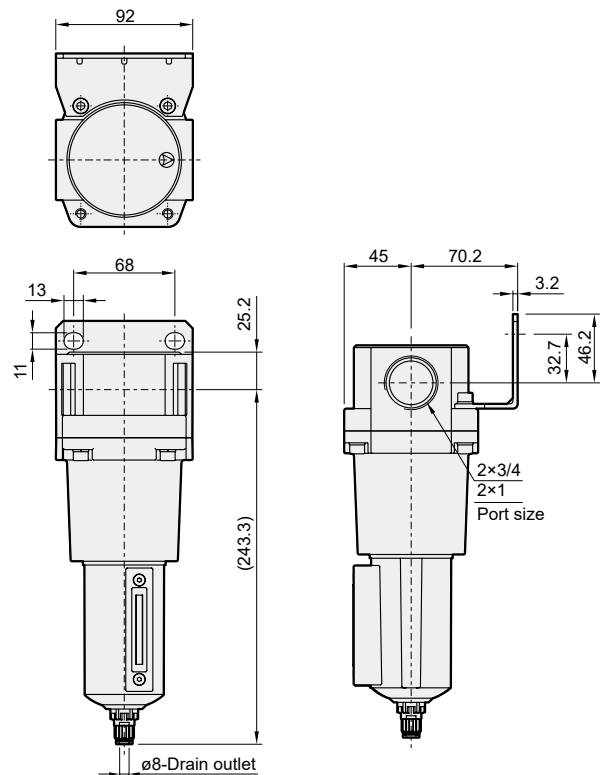

MEMO

NOTE

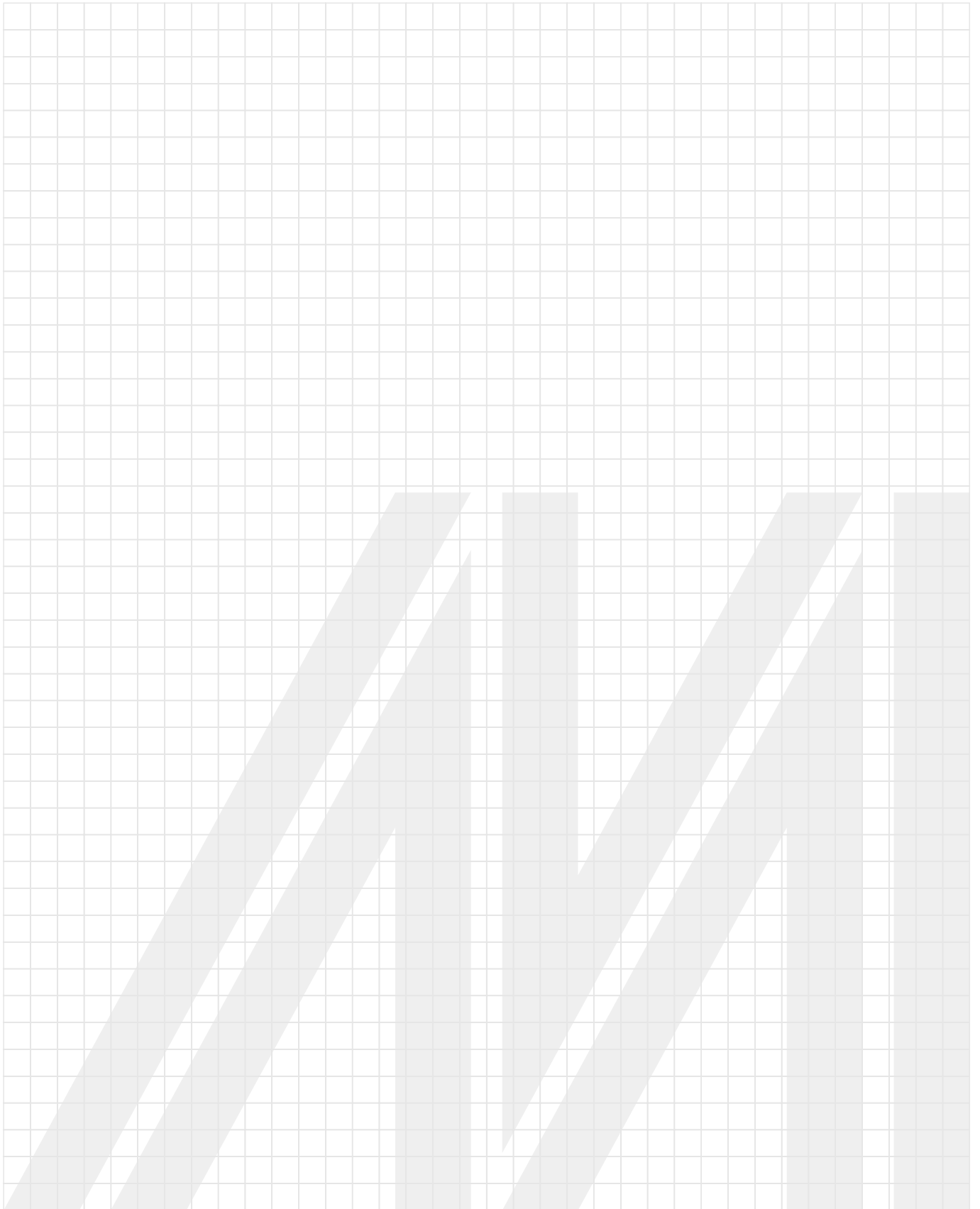

WATER SEPARATOR

PRECISION FILTER

MAM G

MAM B D M F



MAMG

EWS

Water separator

Removal rate 99%±1



Separating the water droplet with a special filtration in the compressed air. * cannot remove moisture.

MAMB

E3

3 μm

Filtration efficiency 99%



Removing the impurities which the particles are bigger than 3μm in compressed air, and extending the life of precision filter in the down-stream, then preventing trouble with the equipment.

MAMD

E03

0.3 μm

Filtration efficiency 99.9%



Removing the oil mist and impurities which the particles are bigger than 0.3μm in compressed air.

MAMM

E001

0.01 μm

Filtration efficiency 99.9%



Removing the oil mist and impurities which the particles are bigger than 0.01μm in compressed air. The filter can be applied to requirement of high purity and extremely low oil mist.

MAMF

E001D

0.01 μm + Deodorization

Filtration efficiency 99.9%



Adsorbing the odor and efficiently removing oil mist with an activated carbon element in compressed air. The filter can be applied to requirement of high purity and oil-free, such as precision painting operations.

* Assembling a MAMD series as pre-filter to extend the life of activated carbon.

Body & Port size

[Rc, G, NPT thread]

MAM*25 1/4, 3/8

MAM*35 3/8, 1/2

MAM*45 1/2, 3/4

MAM*55 3/4, 1

Model & Filter element

Water separator

MAMG

Precision filter

MAMB 3 μm

MAMD 0.3 μm

MAMM 0.01 μm

MAMF 0.01 μm + Deodorization

Maintenance

Replace filter element at least once per year or when pressure drop reaches 0.07 MPa.
(E001D every 6 months)





(Option)

Differential pressure indicator

Double-check with a **Sensor Switch** and an indicator to achieve preventative maintenance.

Caution

This product can't be operated in a location in which pulsations frequently occur.

The indicator is only available with Indicator (Q) and Indicator with switch (QR) models.

Operation image



Initial (No clogging)



Replacement Required Mark

Replacement recommended

An indicator that can confirm intuitively.
A clear cover and colorful lamp enables high visibility.
A mark that help you know when it is time to replace the filter element.

Sensor switch (Option)



RDC(V), RQC(V)

Non-contact, NPN & PNP, N.O.

Operating voltage: 5~30V DC

Switching current: 80mA max.

* Refer to RDC series .

A hint for preventative maintenance

Generally speaking, the filter element should be replaced about once a year. This is just a guideline. The air cleanliness of the secondary side depends on working conditions. To keep your system at optimal conditions, we recommend that



Customers replace filter elements regularly / follow the Replacement mark

Modular combination example (Option)

Model	Joiner set	Air unit	Shutoff valve	Soft start-up valve
MAM*25	BS-MACP403	MA*401-W MA*403	MVHR400	MAVS400
MAM*35				
MAM*45	BS-MACP501	MA*501	—	—
MAM*55				

- Space-saving
- Various combinations available
- Easy assembly (DIY)

EXAMPLE

MAMG35 + **MAMB35** + **MAVS400**
 Water separator 3 μm Shutoff valve

Applicable to the dangerous pneumatic machinery. The valve will control the pressure to increase gradually when the air supply start up, which avoids the accident and machinery damage caused by the sudden action of the actuators.

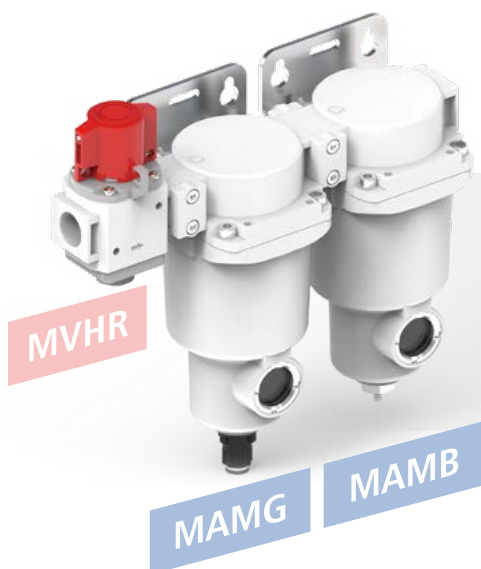

EXAMPLE

MVHR400 + **MAMG35** + **MAMB35**
 Shutoff valve Water separator 3 μm

Applicable to the pneumatic circuit to switch the air supply on and off promptly and release residual pressure while the valve is off.

EXAMPLE
MAMG45 + MAMB45

Water separator

3 μm

Applicable to the main line of the pneumatic circuit or the instance of low compressed air quality demand. For example, the main circuit of the pneumatic system in the factory.



EXAMPLE
MAMB45 + MAMD45 + MAMM45

3 μm

0.3 μm

0.01 μm

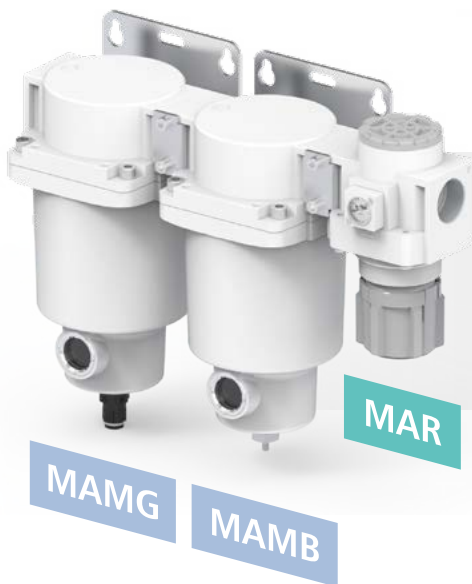
Applicable to the instance of high compressed air quality demand.

EXAMPLE
MAMG55 + MAMB55 + MAR501

Water separator

3 μm

Regulator

Applicable to the instance of pressure regulation requirement. For example, automation industry and machine tool.

EXAMPLE
MAMG55 + MAMB55 + MAL501

Water separator

3 μm

Lubricator

Applicable to the instance of lubrication requirement. For example, automation industry and machine tool.



Features



Selection table



Caution for safety
(Read before installing)



Symbol

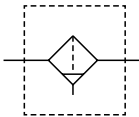

Order example

MAMG 45 – 15A – D – Q –

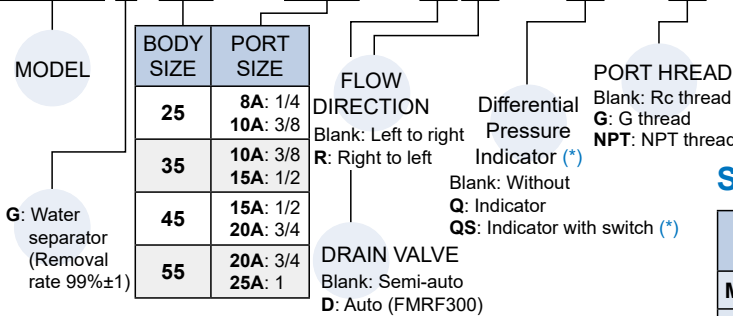

* Please add the sensor when selecting Indicator with switch (QS).
* The models without Indicator (Q) and Indicator with switch (QS) type don't have the installation thread holes.

Order example of sensor switch

RDC V – 2M

Model	Auto switch type	Wire length
RDC: Non-contact RQC: NPN & PNP configurations*	Blank: Straight cable V: Angle cable	2M: L=2000mm QD: M8, 3 Pin connector EQD: M8, 3 Pin connector (Only for RDC)

* Selects the mode based on NPN or PNP wiring configuration.
Always turn off power before wiring; never work on live wires.

MAMG series Water removal rate

$$\text{Water removal rate (\%)} = \frac{\text{Removed water (water droplet) g}}{\text{Inflowed water (water droplet) g}} \times 100$$

* Water separator can remove water droplets, but it cannot remove moisture.

Dimensions

Features

Separating the water droplet with a special filtration in the compressed air. * cannot remove moisture.

Maintenance

Replace filter element at least once per year or when pressure drop reaches 0.07 MPa.

Specification

Model	MAMG							
Body size	25	35	45	55				
Bore No.	8A	10A	10A	15A	15A	20A	20A	25A
Port size	1/4	3/8	3/8	1/2	1/2	3/4	3/4	1
Medium	Air							
Operating pressure range (*)	0.05~1 MPa							
Proof pressure	1.5 MPa							
Ambient temperature	- 5~+60°C (No freezing)							
Filter element	Water separator (Removal rate 99%±1)							
Attachment	L-type bracket							
Sensor switch	RDC(V), RQC(V)							
Weight	610 g	870 g	1450 g	2250 g				

* Standard unit contains semi-auto-drain function when operating pressure below 0.05 MPa.

* Choose auto-drain FMRF300, the pressure range is 0.15~1 MPa.

Selector table – Filter element

Model	Port size	Filter element	Nominal * flow capacity l/min(ANR)	Symbol for order
MAMG25	1/4, 3/8	Water separator (removal rate 99%±1)	650	EWS-G25
MAMG35	3/8, 1/2		1350	EWS-G35
MAMG45	1/2, 3/4		2100	EWS-G45
MAMG55	3/4, 1		3600	EWS-G55

* Nominal flow capacity is at 0.7 MPa, and it varies depending on the operating pressure. If flow rate is over nominal flow capacity, may not meet the specifications of the product.

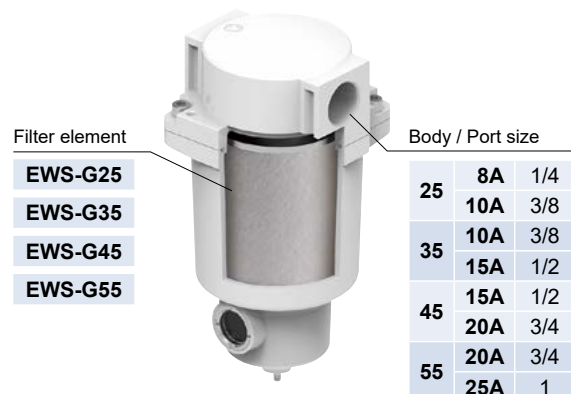

⚠ If flow rate is over nominal flow capacity, may not meet the specifications of the product.

MAMG25

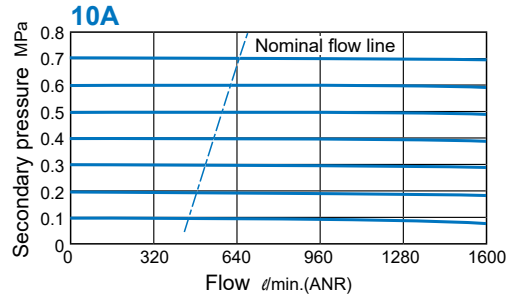
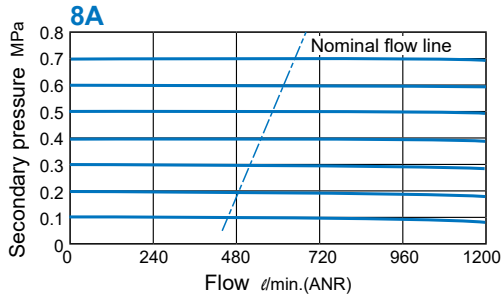

MAMG35

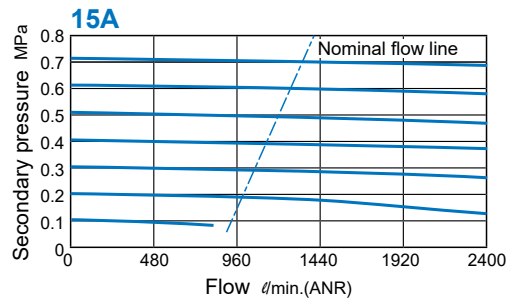
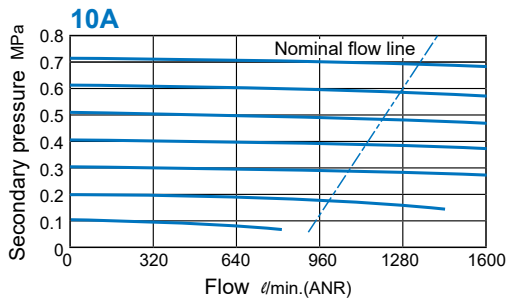

MAMG45

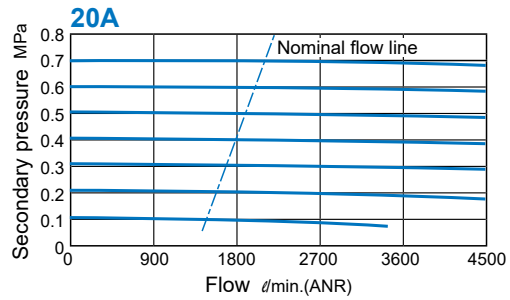
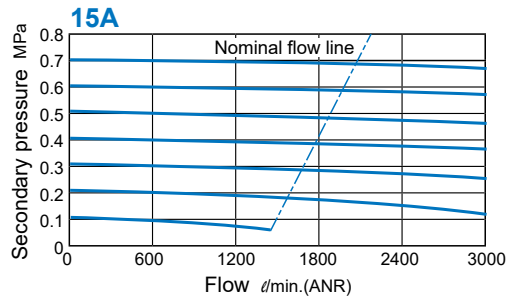

MAMG55

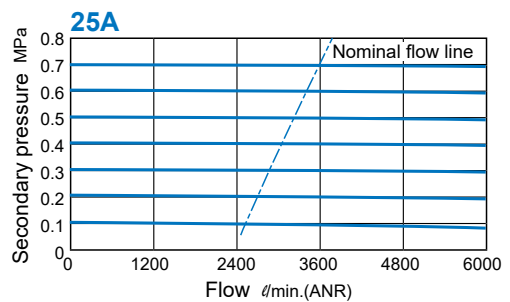
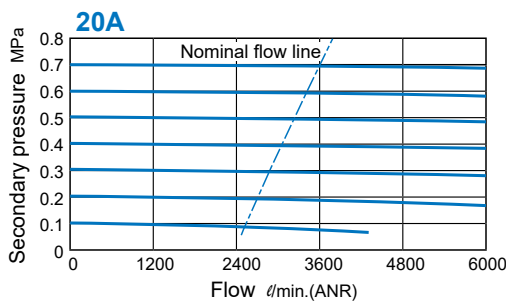

MAMB series 3 μm

AIR UNIT (MAIN LINE FILTER)



Features



Selection table



Caution for safety
(Read before installing)



Symbol

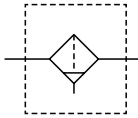

Order example

MAMB 45 - 15A - D □ - Q - □

MODEL

BODY SIZE	PORT SIZE
25	8A: 1/4 10A: 3/8
35	10A: 3/8 15A: 1/2
45	15A: 1/2 20A: 3/4
55	20A: 3/4 25A: 1

B: 3 μm

FLOW DIRECTION

Blank: Left to right
R: Right to left

PORT HREAD

Blank: Rc thread
G: G thread
NPT: NPT thread

Differential Pressure Indicator (*)

Blank: Without

Q: Indicator

QS: Indicator with switch (*)

DRAIN VALVE

Blank: Semi-auto

D: Auto (FMRF300)

* Please add the sensor when selecting Indicator with switch (QS).

* The models without Indicator (Q) and Indicator with switch (QS) type don't have the installation thread holes.

Order example of sensor switch

RDC V - 2M

Model	Auto switch type	Wire length
RDC: Non-contact RQC: NPN & PNP configurations*	Blank: Straight cable	2M: L=2000mm QD: M8, 3 Pin connector EQD: M8, 3 Pin connector (Only for RDC)
	V: Angle cable	2M: L=2000mm

* Selects the mode based on NPN or PNP wiring configuration. Always turn off power before wiring; never work on live wires.

Features

Removing the impurities which the particles are bigger than 3μm in compressed air, and extending the life of precision filter in the down-stream, then preventing trouble with the equipment.

Maintenance

Replace filter element at least once per year or when pressure drop reaches 0.07 MPa.

Specification

Model	MAMB							
Body size	25		35		45		55	
Bore No.	8A	10A	10A	15A	15A	20A	20A	25A
Port size	1/4	3/8	3/8	1/2	1/2	3/4	3/4	1
Medium	Air							
Operating pressure range (*)	0.05~1 MPa							
Proof pressure	1.5 MPa							
Ambient temperature	- 5~+60°C (No freezing)							
Filter element	3 μm							
Attachment	L-type bracket							
Sensor switch	RDC(V), RQC(V)							
Weight	610 g		870 g		1450 g		2250 g	

* Standard unit contains semi-auto-drain function when operating pressure below 0.05 MPa.

* Choose auto-drain FMRF300, the pressure range is 0.15~1 MPa.

Selector table – Filter element

Model	Port size	Filter element *1	Nominal ^{*2} flow capacity l/min(ANR)	Symbol for order
MAMB25	1/4, 3/8	E3: 3μm (filtration efficiency 99%)	650	E3-B25
MAMB35	3/8, 1/2		1350	E3-B35
MAMB45	1/2, 3/4		2100	E3-B45
MAMB55	3/4, 1		3600	E3-B55

*1. Tested according to ISO8573.

*2. Nominal flow capacity is at 0.7 MPa, and it varies depending on the operating pressure. If flow rate is over nominal flow capacity, may not meet the specifications of the product.

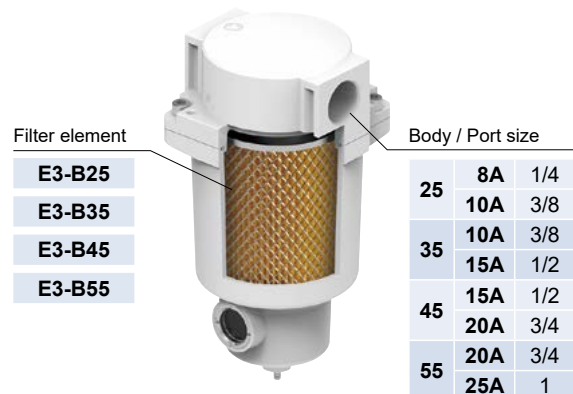

Dimensions



! If flow rate is over nominal flow capacity, may not meet the specifications of the product.

MAMB25

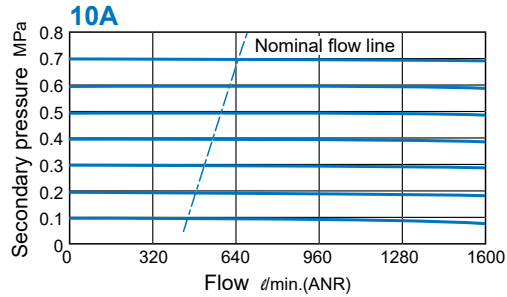
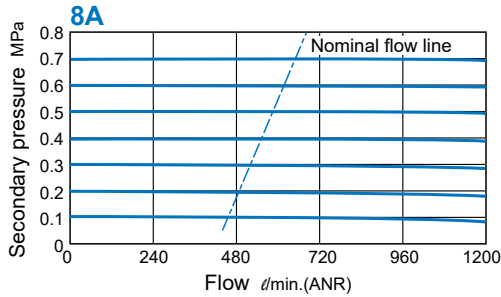

MAMB35

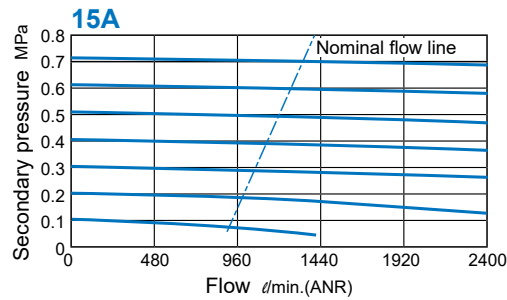
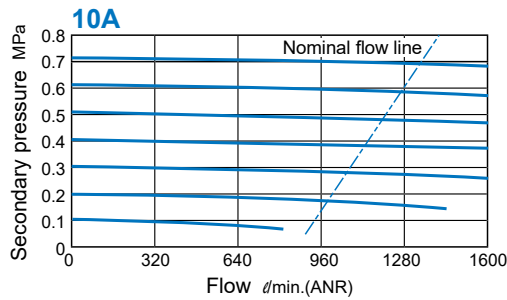

MAMB45

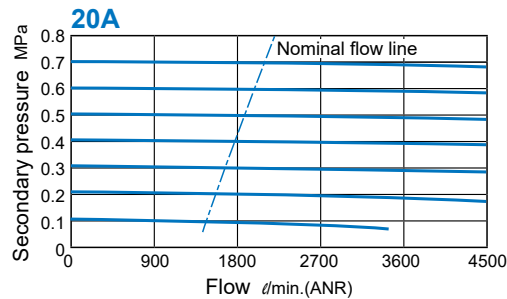
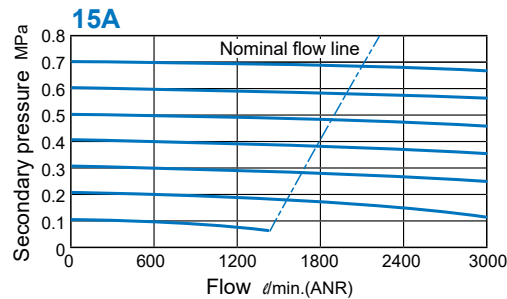

MAMB55

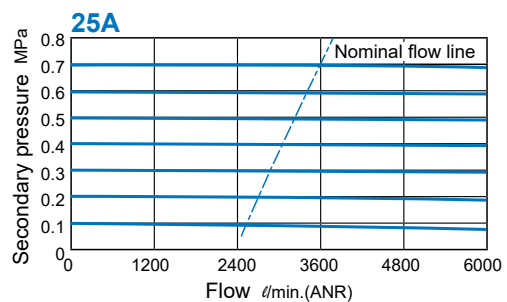
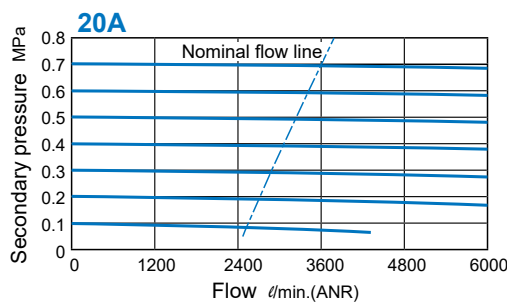

MAMD series 0.3 μm

AIR UNIT (MIST FILTER)



Features



Selection table



Caution for safety
(Read before installing)



Symbol

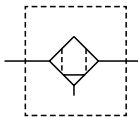

Order example

MAMD 45 – 15A – D□ – Q – □

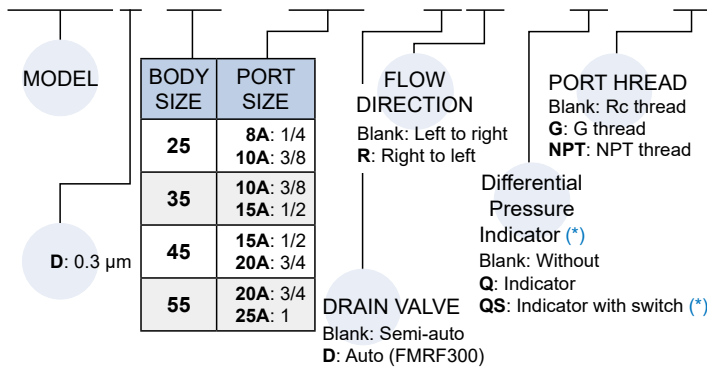

- * Please add the sensor when selecting Indicator with switch (QS).
- * The models without Indicator (Q) and Indicator with switch (QS) type don't have the installation thread holes.

Order example of sensor switch

RDC V – 2M

Model	Auto switch type	Wire length
RDC: Non-contact RQC: NPN & PNP configurations*	Blank: Straight cable V: Angle cable	2M: L=2000mm QD: M8, 3 Pin connector EQD: M8, 3 Pin connector (Only for RDC)
		2M: L=2000mm

- * Selects the mode based on NPN or PNP wiring configuration. Always turn off power before wiring; never work on live wires.

Features

Removing the oil mist and impurities which the particles are bigger than 0.3μm in compressed air.

Maintenance

Replace filter element at least once per year or when pressure drop reaches 0.07 MPa.

Specification

Model	MAMD							
Body size	25	35	45	55				
Bore No.	8A	10A	10A	15A	15A	20A	20A	25A
Port size	1/4	3/8	3/8	1/2	1/2	3/4	3/4	1
Medium	Air							
Operating pressure range (*)	0.05~1 MPa							
Proof pressure	1.5 MPa							
Ambient temperature	- 5~+60°C (No freezing)							
Filter element	0.3 μm							
Attachment	L-type bracket							
Sensor switch	RDC(V), RQC(V)							
Weight	610 g	870 g	1450 g	2250 g				

* Standard unit contains semi-auto-drain function when operating pressure below 0.05 MPa.

* Choose auto-drain FMRF300, the pressure range is 0.15~1 MPa.

Selector table – Filter element

Model	Port size	Filter element *1	Residual oil content *2	Nominal flow capacity l/min(ANR) *3	Symbol for order
MAMD25	1/4, 3/8	E03: 0.3μm (filtration efficiency 99.9%)	< 0.1 mg/m ³	650	E03-D25
MAMD35	3/8, 1/2			1350	E03-D35
MAMD45	1/2, 3/4			2100	E03-D45
MAMD55	3/4, 1			3600	E03-D55

*1. Tested according to ISO8573.

*2. Tested according to ISO12500-1, inlet concentration 10mg/m³

*3. Nominal flow capacity is at 0.7 MPa, and it varies depending on the operating pressure. If flow rate is over nominal flow capacity, may not meet the specifications of the product.

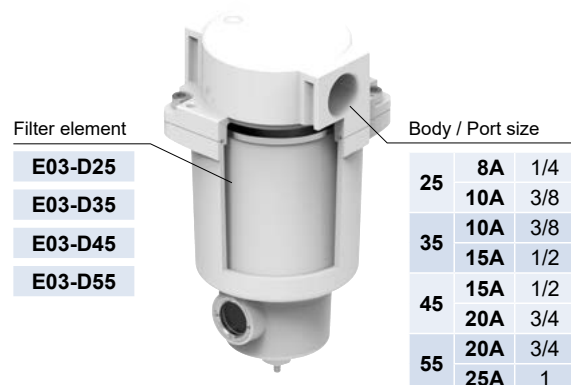

Dimensions



! If flow rate is over nominal flow capacity, may not meet the specifications of the product.

MAMD25

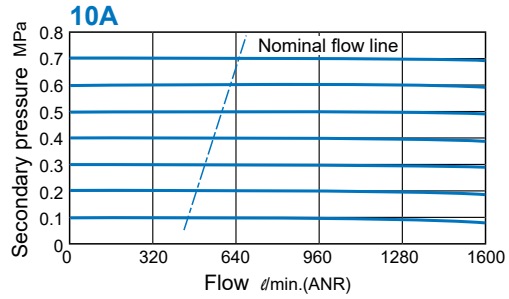
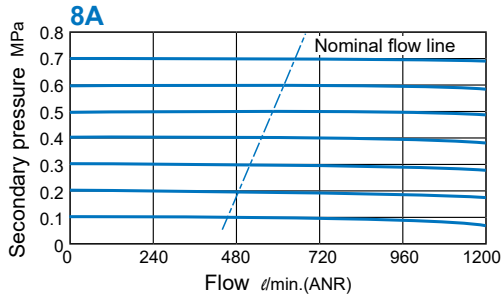

MAMD35

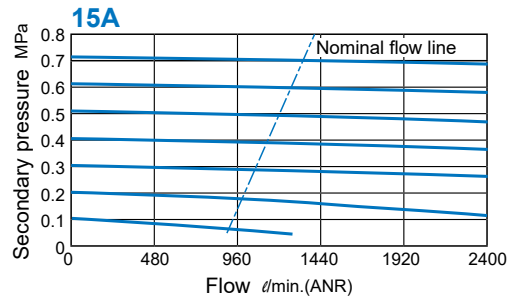
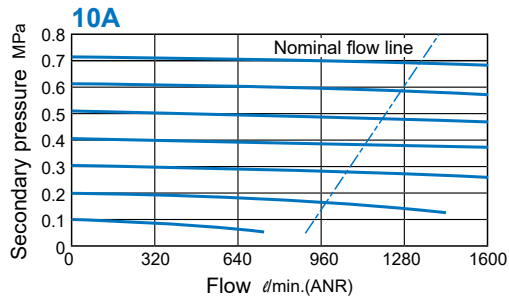

MAMD45

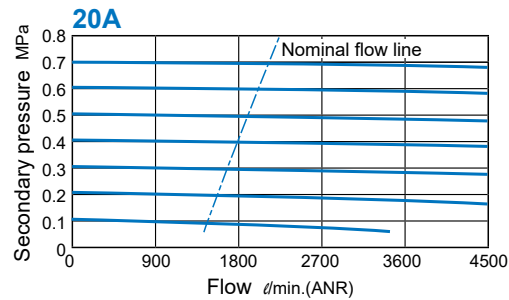
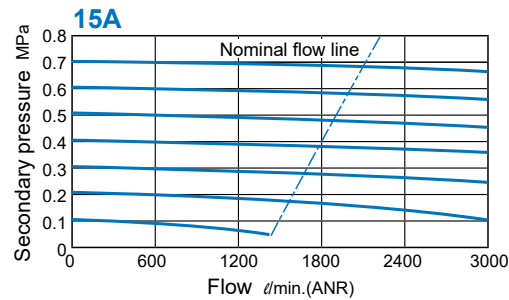

MAMD55

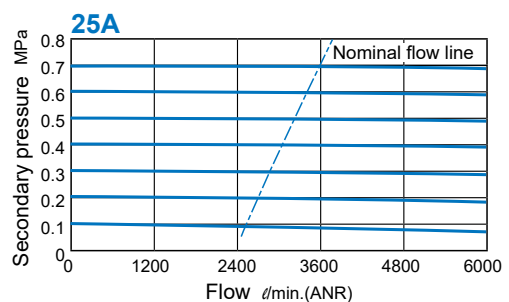
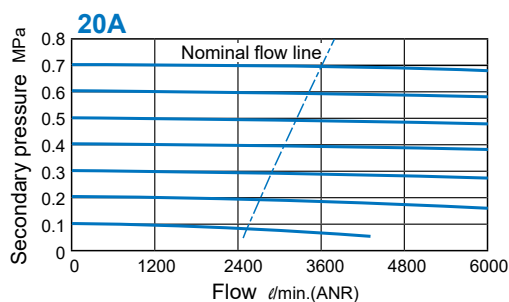

MAMM series 0.01 μm

AIR UNIT (MICRO MIST FILTER)



Features



Selection table



Caution for safety
(Read before installing)



Symbol

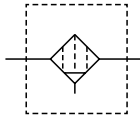

Order example

MAMM 45 – 15A – D □ – Q – □

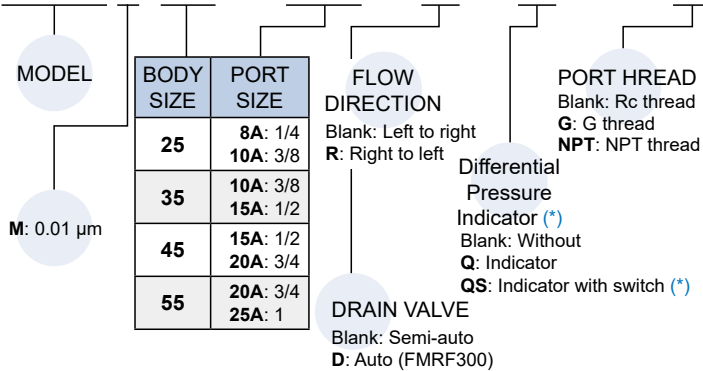

- * Please add the sensor when selecting Indicator with switch (QS).
- * The models without Indicator (Q) and Indicator with switch (QS) type don't have the installation thread holes.

Order example of sensor switch

RDC V – 2M

Model	Auto switch type	Wire length
RDC: Non-contact RQC: NPN & PNP configurations*	Blank: Straight cable	2M: L=2000mm QD: M8, 3 Pin connector EQD: M8, 3 Pin connector (Only for RDC)
	V: Angle cable	2M: L=2000mm

- * Selects the mode based on NPN or PNP wiring configuration. Always turn off power before wiring; never work on live wires.

Dimensions



Features

Removing the oil mist and impurities which the particles are bigger than 0.01μm in compressed air. The filter can be applied to requirement of high purity and extremely low oil mist.

Maintenance

Replace filter element at least once per year or when pressure drop reaches 0.07 MPa.

Specification

Model	MAMM							
Body size	25		35		45		55	
Bore No.	8A	10A	10A	15A	15A	20A	20A	25A
Port size	1/4	3/8	3/8	1/2	1/2	3/4	3/4	1
Medium	Air							
Operating pressure range (*)	0.05~1 MPa							
Proof pressure	1.5 MPa							
Ambient temperature	- 5~+60°C (No freezing)							
Filter element	0.01 μm							
Attachment	L-type bracket							
Sensor switch	RDC(V), RQC(V)							
Weight	610 g		870 g		1450 g		2250 g	

* Standard unit contains semi-auto-drain function when operating pressure below 0.05 MPa.

* Choose auto-drain FMRF300, the pressure range is 0.15~1 MPa.

Selector table – Filter element

Model	Port size	Filter element *1	Residual oil content *2	Nominal flow capacity l/min(ANR) *3	Symbol for order
MAMM25	1/4, 3/8	E001: 0.01μm (filtration efficiency 99.9%)	< 0.01 mg/m ³	500	E001-M25
MAMM35	3/8, 1/2			1000	E001-M35
MAMM45	1/2, 3/4			2000	E001-M45
MAMM55	3/4, 1			3600	E001-M55

*1. Tested according to ISO8573.

*2. Tested according to ISO12500-1, inlet concentration 10mg/m³

*3. Nominal flow capacity is at 0.7 MPa, and it varies depending on the operating pressure. If flow rate is over nominal flow capacity, may not meet the specifications of the product.

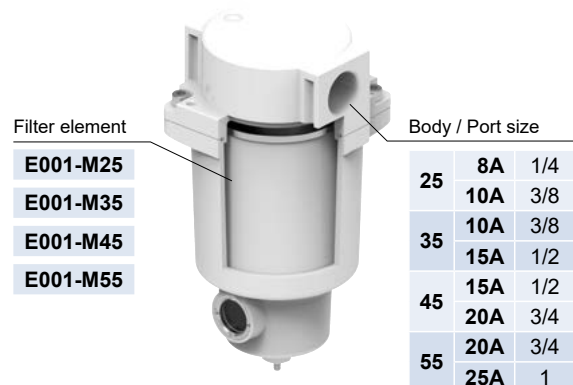

! If flow rate is over nominal flow capacity, may not meet the specifications of the product.

MAMM25

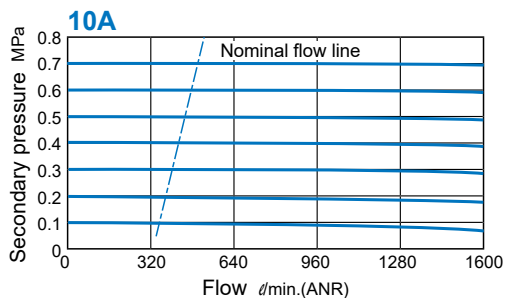
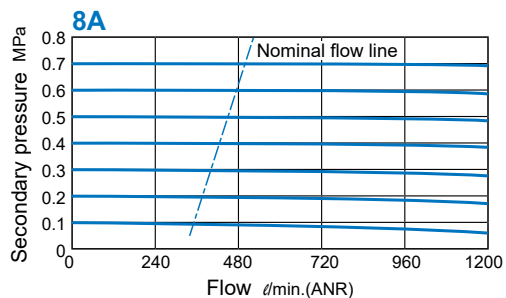

MAMM35

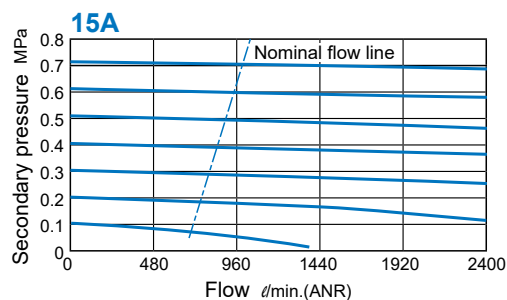
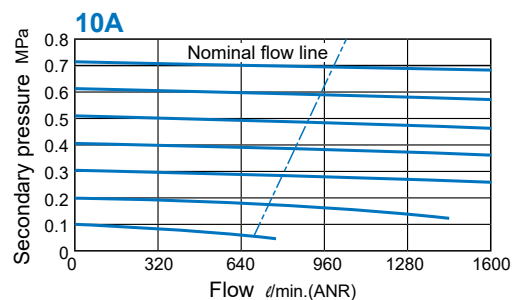

MAMM45

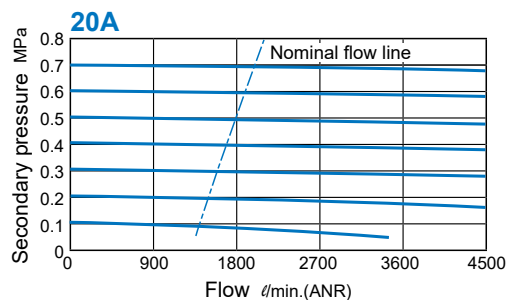
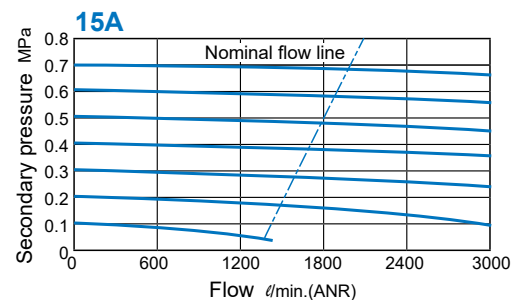

MAMM55

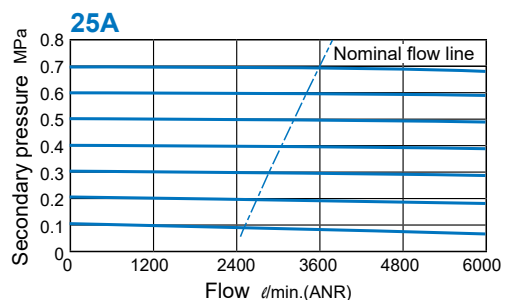
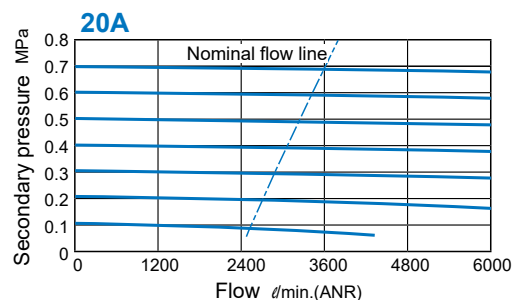

MAMF series 0.01 μm + Deodorization

AIR UNIT (ODOR REMOVAL FILTER)



Features



Selection table



Caution for safety
(Read before installing)



Symbol

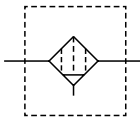

Order example

MAMF 45 – 15A – D □ – Q – □

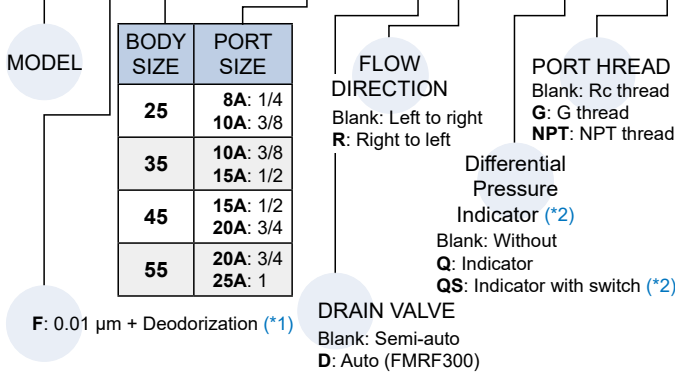

- *1. Assembling a MAMD series as pre-filter of activated carbon.
- *2. Please add the sensor when selecting Indicator with switch (QS). The models without Indicator (Q) and Indicator with switch (QS) type don't have the installation thread holes.

Order example of sensor switch

RDC V – 2M

Model	Auto switch type	Wire length
RDC: Non-contact RQC: NPN & PNP configurations*	Blank: Straight cable V: Angle cable	2M: L=2000mm QD: M8, 3 Pin connector EQD: M8, 3 Pin connector (Only for RDC)
		2M: L=2000mm

- * Selects the mode based on NPN or PNP wiring configuration. Always turn off power before wiring; never work on live wires.

Features

Adsorbing the odor and efficiently removing oil mist with an activated carbon element in compressed air. The filter can be applied to requirement of high purity and oil-free, such as precision painting operations.

* Assembling a MAMD series as pre-filter to extend the life of activated carbon.

Maintenance

Replace filter element at least every 6 months or when pressure drop reaches 0.07 MPa.

Specification

Model	MAMF							
Body size	25		35		45		55	
Bore No.	8A	10A	10A	15A	15A	20A	20A	25A
Port size	1/4	3/8	3/8	1/2	1/2	3/4	3/4	1
Medium	Air							
Operating pressure range (*1)	0.05~1 MPa							
Proof pressure	1.5 MPa							
Ambient temperature	- 5~+60°C (No freezing)							
Filter element	0.01μm+Deodorization (*2)							
Attachment	L-type bracket							
Sensor switch	RDC(V), RQC(V)							
Weight	610 g		870 g		1450 g		2250 g	

- *1. Standard unit contains semi-auto-drain function when operating pressure below 0.05 MPa. Choose auto-drain FMRF300, the pressure range is 0.15~1 MPa.
- *2. Assembling a MAMD series as pre-filter to extend the life of activated carbon.

Selector table – Filter element

Model	Port size	Filter element *1	Residual oil content *2	Nominal*3 flow capacity /min(ANR)	Symbol for order
MAMF25	1/4, 3/8	E001D: 0.01μm + Deodorization (filtration efficiency 99.9%)	< 0.005 mg/m ³	500	E001D-F25
MAMF35	3/8, 1/2			1000	E001D-F35
MAMF45	1/2, 3/4			2000	E001D-F45
MAMF55	3/4, 1			3600	E001D-F55

- *1. Tested according to ISO8573.
- *2. Tested according to ISO12500-1, inlet concentration 10mg/m³
- *3. Nominal flow capacity is at 0.7 MPa, and it varies depending on the operating pressure. If flow rate is over nominal flow capacity, may not meet the specifications of the product.

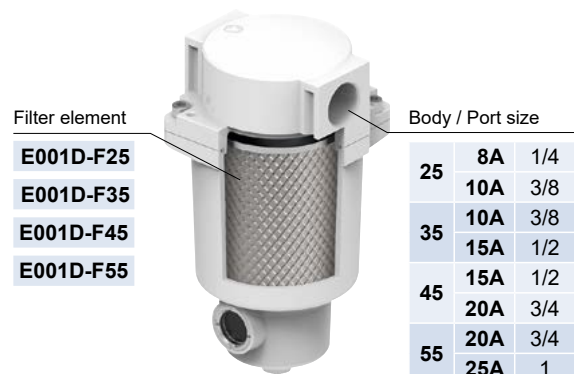

! If flow rate is over nominal flow capacity, may not meet the specifications of the product.

MAMF25

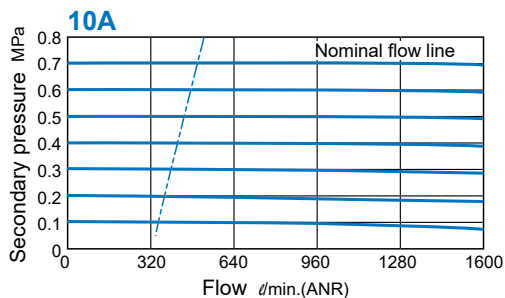
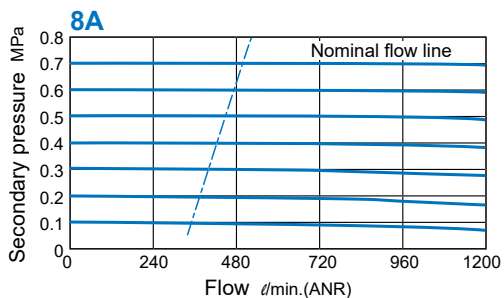

MAMF35

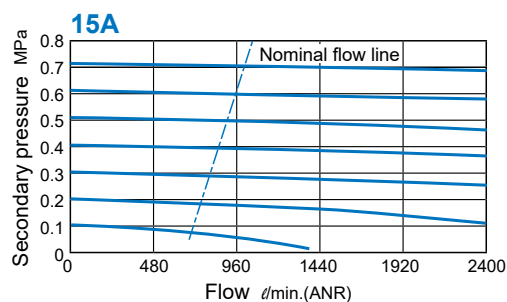
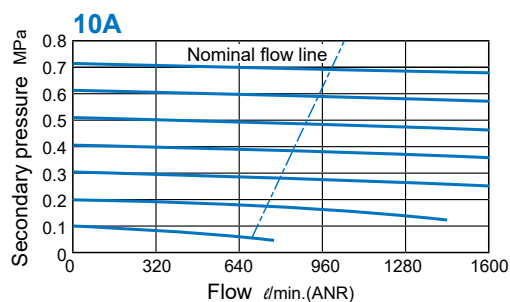

MAMF45

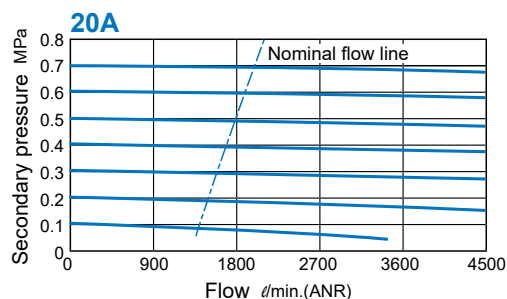
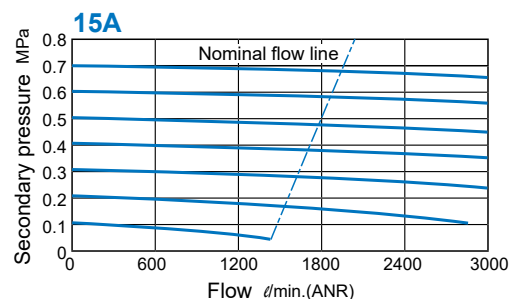

MAMF55

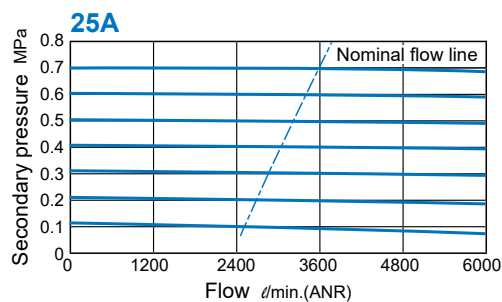
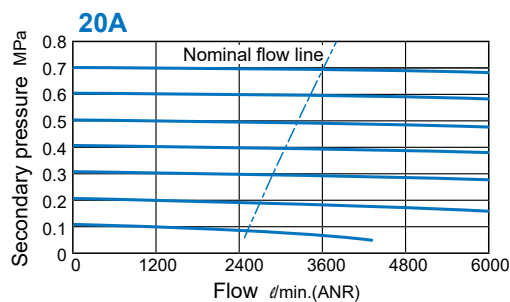

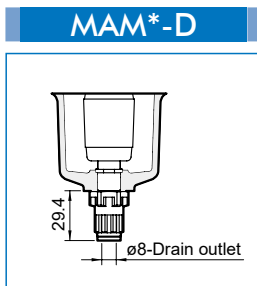
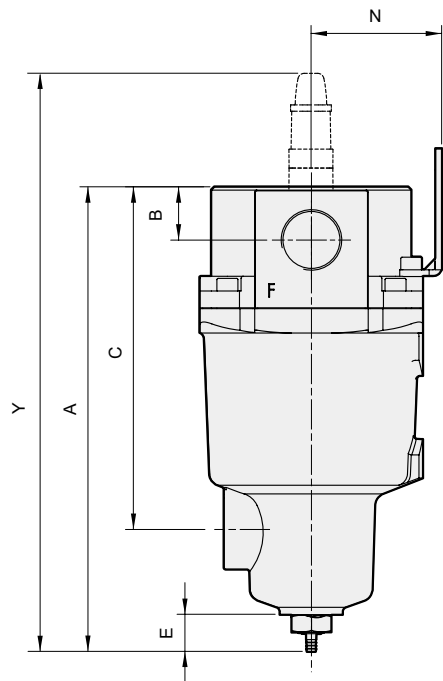
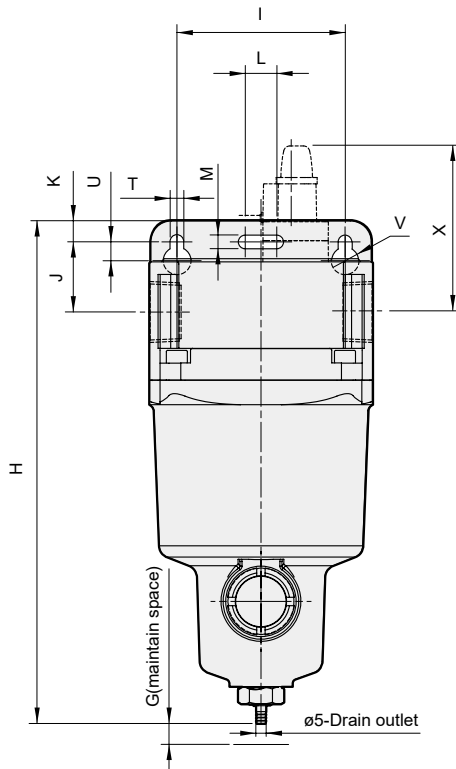
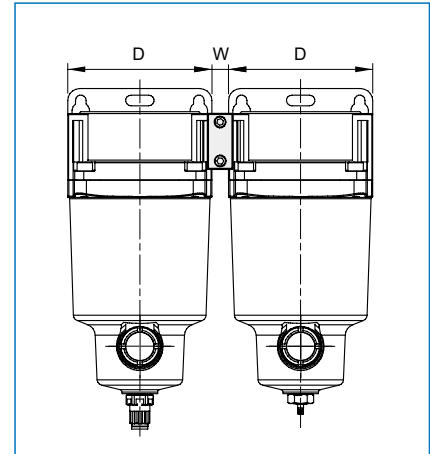
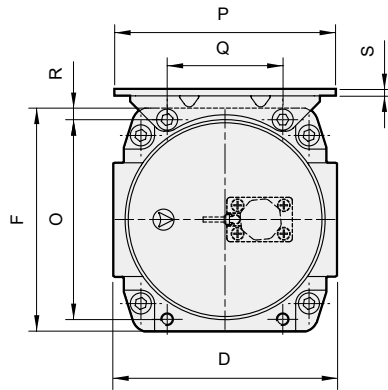

Code Model	Port size	A	B	C	D	E	F	G	H	I	J	K	T	U	L	M	V	N	O	P	Q	R	S	W	X	Y
MAM*25	1/4", 3/8"	171.6	16.5	113.5	76	17.6	76	10	187.1	66	24	8	6	6	6	6	10	47	68.5	80	35	3.8	2	10	71.5	226.6
MAM*35	3/8", 1/2"	199.1	16.5	141	90	17.6	90	10	218.6	80	28	8	7	7	7	7	12	53.4	80.5	95	44	4.8	2.3	10	71.5	254.1
MAM*45	1/2", 3/4"	221.1	25.2	163	106	17.6	106	10	236.9	90	31	10	9	9	9	9	15	62	95	111	55	5.5	3.2	14	80.2	276.1
MAM*55	3/4", 1"	256.1	25.2	198.5	122	17.6	122	10	275.6	100	34.7	10	9	9	15	9	15	72	106	122	63	8	3.2	14	80.2	311.1

Available components (Option)

Model	Joiner set	Air unit	Shutoff valve	Soft start-up valve
MAM*25	BS-MACP403	MA*401-W	MVHR400	MAVS400
MAM*35		MA*403		
MAM*45	BS-MACP501	MA*501	-	-
MAM*55				

- Space-saving.
- Various combinations available.
- Easy assembly (DIY).

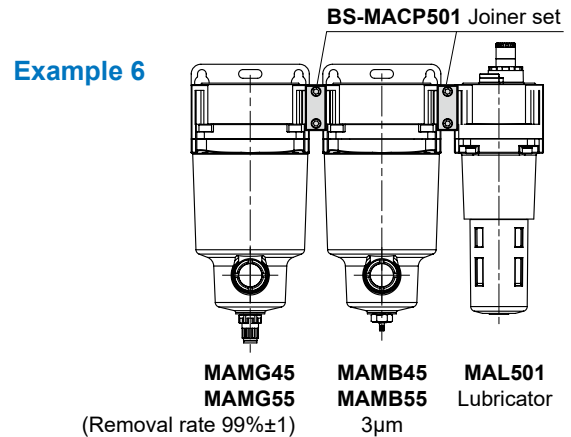
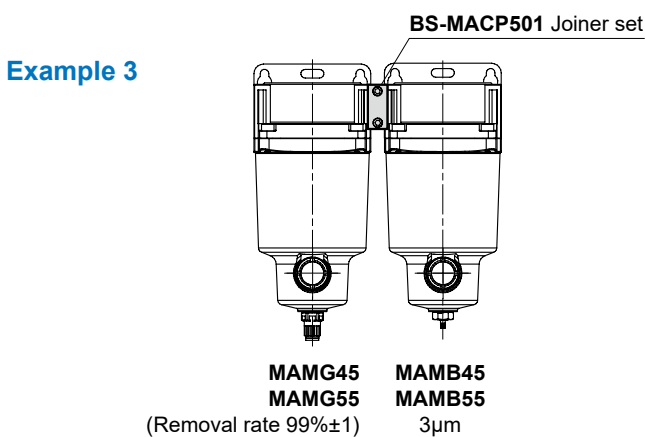
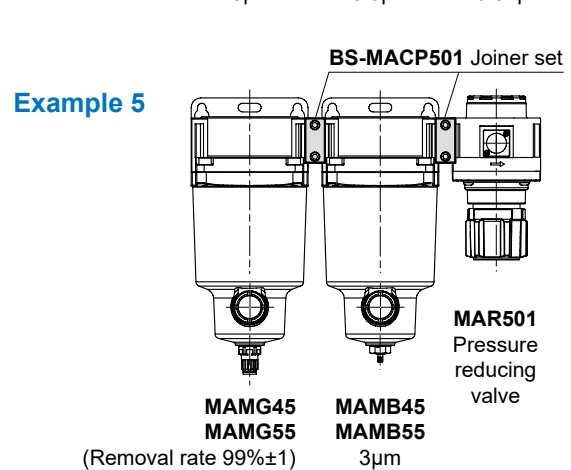
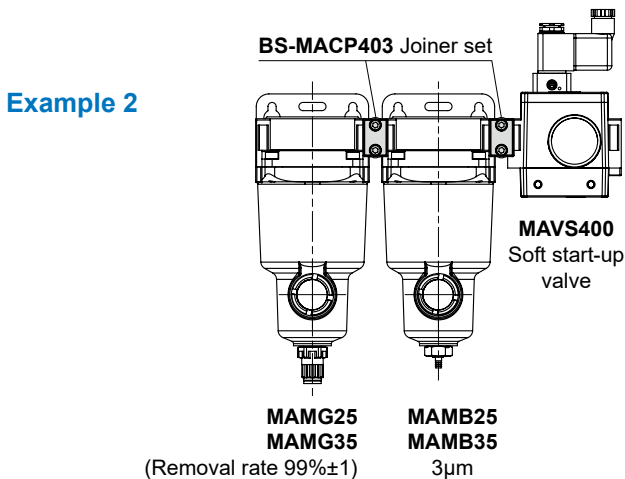
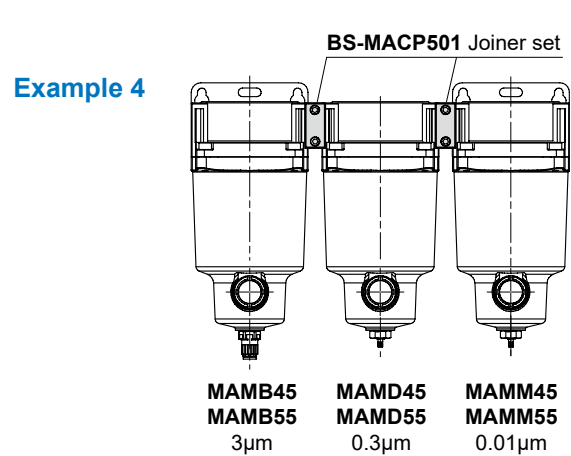
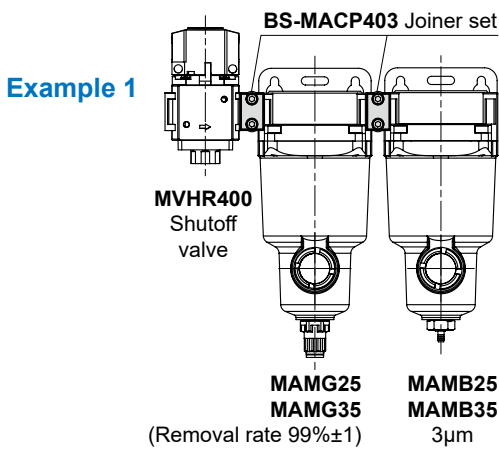



Caution for safety
(Read before installing)



- Start-up valve for low speed air supply to gradually raise initial pressure in an air system and for quick exhaust by cutting off air supply.
- Combination with modular type air units (F.R.L. unit).
- Adaptor possess smooth pressure relief is optional.

Specification

Model	MAVS200	MAVS300	MAVS400
Bore No.	8A	10A	15A
Port size	1/4	3/8	1/2
Medium	Air		
Operating pressure range	0.25~1 MPa		
Effective orifice	1(P)→2(A)	20 mm ²	37 mm ²
	2(A)→3(R)	24 mm ²	49 mm ²
Ambient temperature	0~+60°C		
Voltage	AC110V, 220V (50/60)Hz, DC24V		
Power consumption	Standard	AC=4.8/4.4VA, 6/4.9VA DC=2W	
	Power saving	DC=Start: 2W(*) Power saving: 0.5W	
Available voltage range	±10%		
Insulation class	F class		
Option	Pressure gauge (PG-40), L type bracket		
Weight	450 g	520 g	800 g

* Power saving covert time 100ms.

Order example

MAVS400 - 15A - 1 - □ - B - AC110 - L - □

MODEL

200
300
400

PORT SIZE

8A: 1/4 (for 200 type)
10A: 3/8 (for 300 type)
15A: 1/2 (for 400 type)

BRACKET

Blank: Without
B: L type bracket

VOLTAGE

AC220V(50/60)Hz
AC110V(50/60)Hz
DC24V

PORT THREAD

Blank: Rc thread
G: G thread
NPT: NPT thread

PRESSURE GAUGE

Blank: Without pressure gauge
C: Pressure gauge (PG-40)

EXTERIOR COLOR (*)

1: Silver (for air unit 401 series)
3: Cool gray (for air unit 401-W, 403 series)

* MAVS200/300 only have cool gray, if selected MAVS200/300 type can skip this option.

Symbol

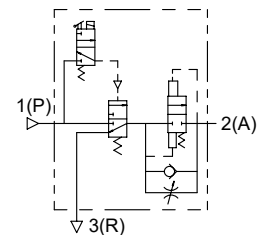

ELECTRIC CONNECTION

Standard	
Blank	DIN terminal
L	DIN terminal with LED indicator
E	Explosion protection (Table 1)(Black coil)
Power saving (for DC24V)	
KL	DIN terminal with LED indicator

Order example of Adaptor

MAVS400 - F - □

MODEL

200
300
400

ADAPTOR
with smooth
pressure
relief

PORT THREAD

Blank: Rc thread
G: G thread
NPT: NPT thread

* By using the adaptor with smooth pressure relief, when air supplied from valve is off, the air inside the body will be released, smoothly and safely. (The exhausting duration will be around 40 seconds for 10L volume)

Table 1

Property for explosion-proof type

Anti-explosion class	Ex mb IIC T4 Gb
Voltage	AC110V / 220V(50/60)Hz, DC24V
Power consumption	AC110V=4.5VA, AC220V=4.8VA, DC=5W
Available valtage range	±10%
Insulation class	F class
Wire length	3 m

Piping note

When the air current is restricted or insufficient pressure, the main valve will not function / switch normally and it could cause air to leak from the R port.
The total effective orifice of the piping material and component on the P port side:

MAVS200	Total effective orifice ≥5mm ²
MAVS300	Total effective orifice ≥22mm ²
MAVS400	Total effective orifice ≥35mm ²

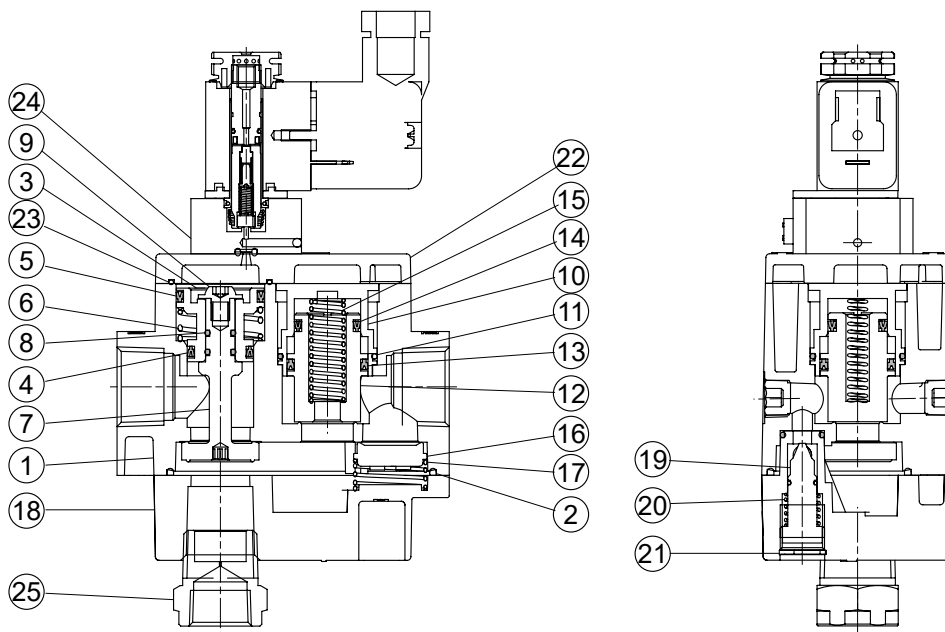

Material

No.	Part name	Material
1	Body	Aluminum alloy
2	Body packing	NBR
3	Piston A	Aluminum alloy
4	Seal ring	NBR
5	Rod packing	NBR
6	Piston A spring	SWP
7	Main valve assembly	Copper+NBR
8	O-ring	NBR
9	Screw	Alloy steel
10	Snap ring	Spring steel
11	O-ring	NBR
12	Piston B	Copper+NBR
13	Seal ring	NBR
14	Seal ring	NBR
15	Piston B spring	Stainless steel
16	Check valve	Copper+NBR
17	Check valve spring	Stainless steel
18	Cap	Aluminum alloy
19	Needle valve	Copper
20	Needle valve spring	SWP
21	Snap ring	Spring steel
22	Cover	Aluminum alloy
23	Cover ring	NBR
24	Pilot valve assembly	-
25	Adaptor with smooth pressure relief	Aluminum alloy

Flow feature

Piston B switching pressure (Close→Open)

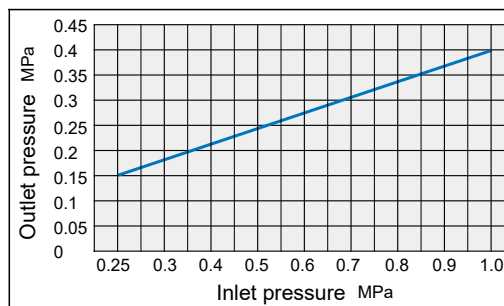

Needle valve flow characteristics

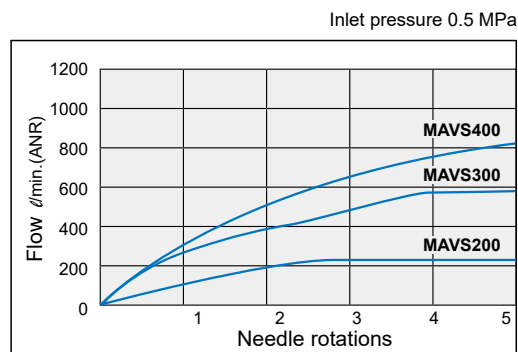

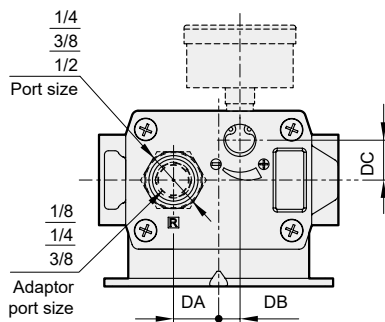
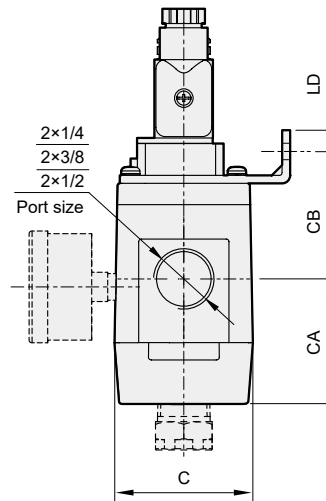
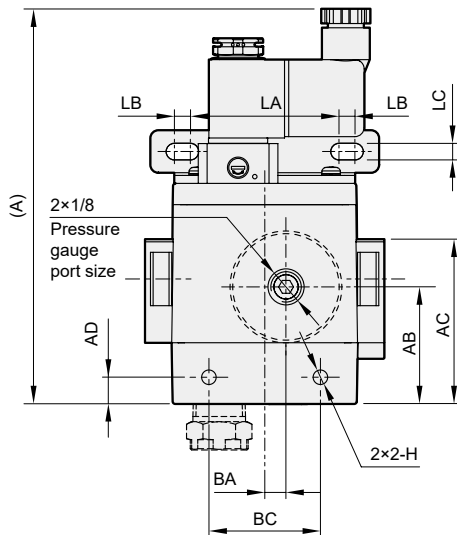
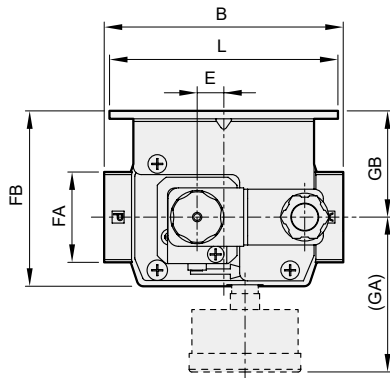

MAVS*-F

Adaptor with smooth pressure relief

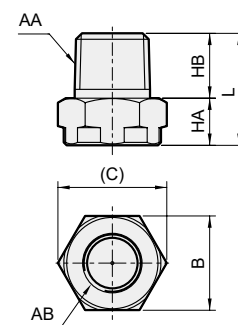

Code Model	A	AB	AC	AD	B	BA	BC	C	CA	CB	DA	DB	DC
200	126.6	31	41.2	7.5	66	5	29	39.6	31.2	40.2	11	5	11
300	134	34	50.5	8.5	78	5	28	47.6	36	31.9	14	5	14
400	149	44	62	10	90	8	42	52	47	48	17	8	15

Code Model	E	FA	FB	GA	GB	H	L	LA	LB	LC	LD
200	8.9	35	47.3	53.8	27.5	M4×0.7×4.5 dp	68	50	3.5	4.3	7
300	11	29	56.3	55	32.5	M5×0.8×5 dp	76	55	5	5.2	8
400	10	34	66	60	40	M6×1.0×6 dp	86	56	6	6.2	8

Code Model	AA	AB	B	C	HA	HB	L	Weight
200	R1/4	Rc1/8	16	18.5	8	11	19	6 g
200-N	NPT1/4	NPT1/8	16	18.5	8	15.1	23.1	7 g
200-G	G1/4	G1/8	19	21.9	8	7	15	7 g
300	R3/8	Rc1/4	19	21.9	11	12	23	11 g
300-N	NPT3/8	NPT1/4	19	21.9	11	15.2	26.2	12 g
300-G	G3/8	G1/4	25	28.9	11	8.5	19.5	15 g
400	R1/2	Rc3/8	22	25.4	11	15	26	15 g
400-N	NPT1/2	NPT3/8	22	25.4	11	19.8	30.8	17 g
400-G	G1/2	G3/8	27	31.2	11	11.5	22.5	19 g

Combination with air units (F.R.L. unit)

Air unit (F.R.L.)		Valve
MA**302		MAVS300
MA**401	MA**403	MAVS400

EX: MACT403+MAVS400

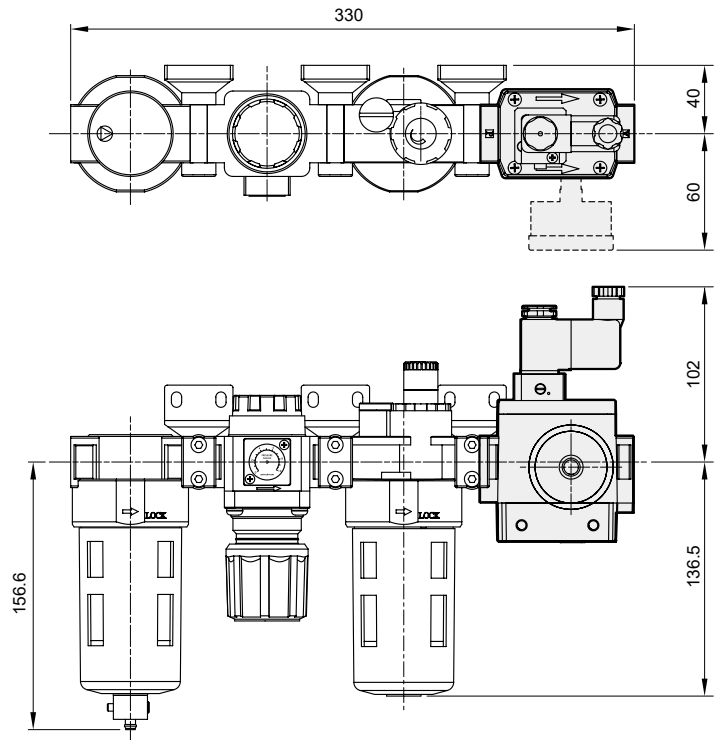

Bracket / Joiner set

BT: T type bracket/ BL: L type bracket/ BS: Joiner set

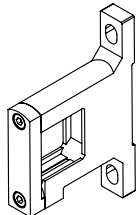
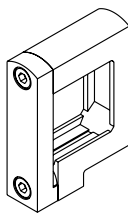
Order example	BT-MACP302	BS-MACP302
Pictures		
Applicable model	MACP302, MACT302	MACP302, MACT302

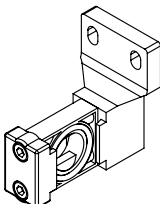
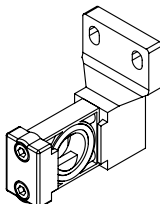
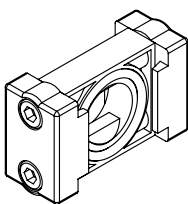
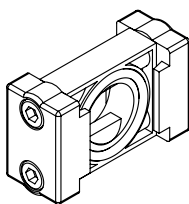
Order example	BL-MACP401	BL-MACP403	BS-MACP401	BS-MACP403
Pictures				
Applicable model	MACP401, MACT401	MACP401-W, MACT401-W MACP403, MACT403	MACP401, MACT401	MACP401-W, MACT401-W MACP403, MACT403



Differential pressure gauge

Features

Air filter engineering original imported top quality filter element 98% voids volume provides long life time with lowest operating cost. Pleated media provides far more filter surface, therefore more dirt holding capacity, lower diff. pressure and lower running cost compare to conventional wrapped element designs.

A. Filter media: AFE uses high performance borosilicate microfiber with 98% void volume. The pleated design assures the highest possible filtration area within the element geometry to provide low operating cost.

B. End cap: An O-ring sealed alumina end cap for the highest possible operating temperature together with tie rod construction provides highest possible security against pressure spikes in the compressed air system.

C. Stainless steel support sleeves: Inner and outer SS support sleeves for supporting the filter media, incl. a mechanical pre-separation.

Order example of port type

MJF – CP – 60F □ – D – G

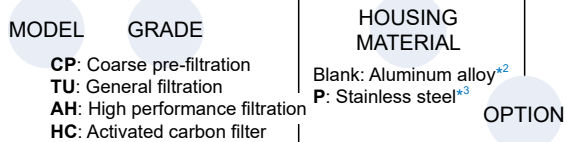

CP: Coarse pre-filtration
 TU: General filtration
 AH: High performance filtration
 HC: Activated carbon filter

Blank: Aluminum alloy*²
 P: Stainless steel*³

OPTION

Code	Pressure (barG)		
	Blank	Standard	~10
10F~150F	H1	High* ³ pressure	11~20
	H2		21~30
	H3		31~40
	H4		41~50
10L~150L* ¹	Blank	Standard	7~10

Blank: Manual drain (16 barG)
 D: Auto drain (50 barG)
 G: Differential pressure gauge

Order example of flang type

MJL – TU – 200LH1 □ – D – G

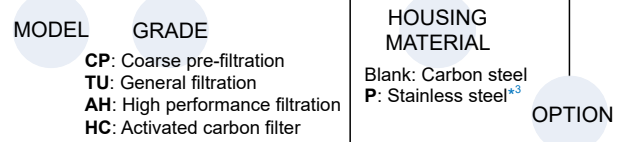

CP: Coarse pre-filtration
 TU: General filtration
 AH: High performance filtration
 HC: Activated carbon filter

Blank: Carbon steel
 P: Stainless steel*³

OPTION

Code	Pressure (barG)		
	Blank	Standard	~10
200L ~ 1250L	H1	High* ³ pressure	11~20
	H2		21~30
	H3		31~40
	H4		41~50

Blank: Manual drain (16 barG)
 D: Auto drain (50 barG)
 G: Differential pressure gauge

*1. Only for "P" stainless steel housing material.

*2. When choosing the high pressure type, the material is carbon steel.

*3. Stainless steel and high pressure are specially customized. For inquiries, please contact us.

Specification of grade (filter element)

Filtration grade (Filter element)	CP (C)	TU (T)	AH (A)	HC (H)
Features	Coarse pre-filtration	General filtration	High performance filtration	Activated carbon filter
Particle removal micron	3.0 μ	1.0 μ	0.01 μ	n/a
Oil contaminant retention down to	n/a	0.1	0.01	0.003
Nominal initial pressure drop	0.03	0.05	0.09	0.10
Max. operating temp.	80	60	60	60
Life time	8000			1000

Correction factor

Inlet pressure (MPa)	0.1	0.2	0.3	0.4	0.5	0.6	0.7	0.8	0.9	1.0	1.1	1.2	1.3	1.4	1.5	1.6
Correction factor	0.25	0.38	0.50	0.65	0.75	0.88	1.0	1.13	1.25	1.38	1.50	1.63	1.75	1.88	2.00	2.13

Filter element

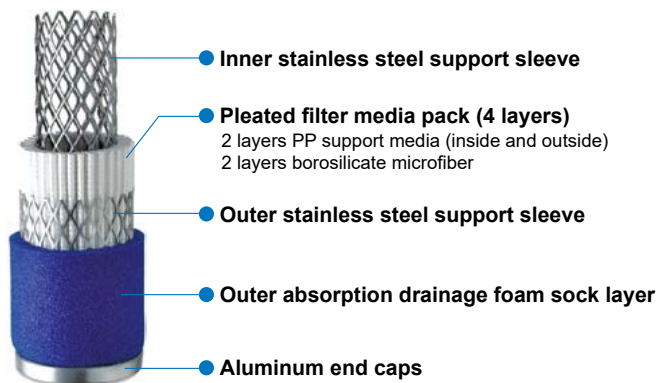

Filter element / Order example

C – NF1E × 1

GRADE

C: Coarse Pre-filtration (3.0 μ)
 T: General filtration (1.0 μ)
 A: High performance filtration (0.01 μ)
 H: Activated carbon filter

Model	Filter element × Q'ty	
MJJ Series (Ported)	10F	NF1E×1
	15F	NF1E×1
	25F	NF2E×1
	40F	NF2E×1
	60F	NF3E×1
	100F	NF4E×1
	150F	NL1E×1
	10LP	NF1E×1
	15LP	NF1E×1
	25LP	NF2E×1
MJL Series (Flanged)	40LP	NF2E×1
	60LP	NF3E×1
	100LP	NF4E×1
	150LP	NL1E×1
	200L	NL1E×1
	400L	NL1E×2
	700L	NL1E×3
	900L	NL1E×4
	1250L	NL1E×5

Structure

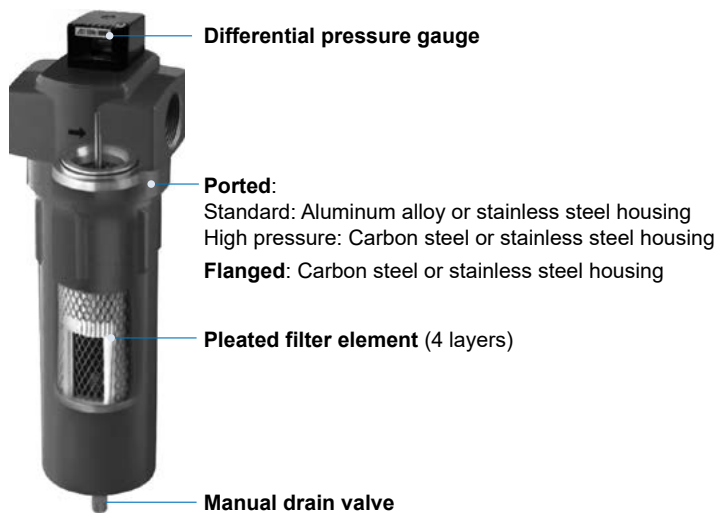

Application

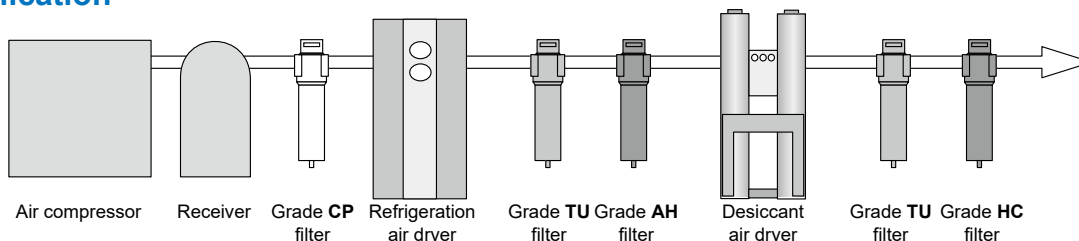

Note: 1. Grade TU filters after desiccant air dryer is for particle removal. Must be installed reversely and auto drain is unnecessary.
 2. Grade HC filters is for oil vapor and odor removal. Auto drain and differential pressure gauge are not required.

MJF-*-D

10F~150F

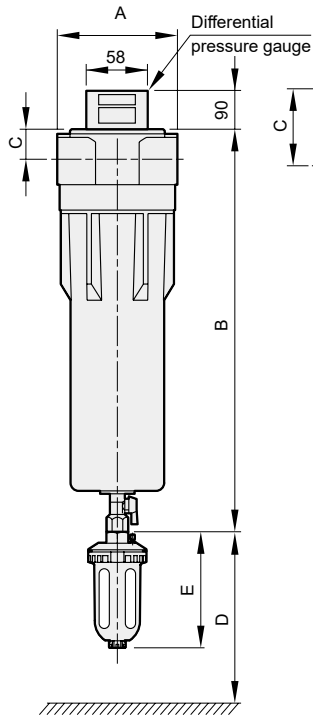

MJF-LP-D

Customize 10LP~150LP

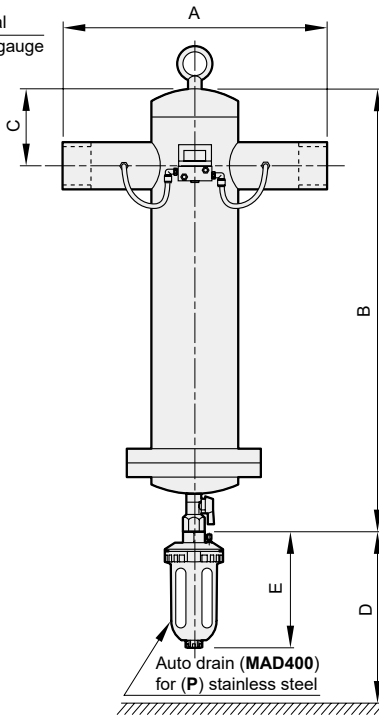

MJL-*-D

Standard 200L~1250L

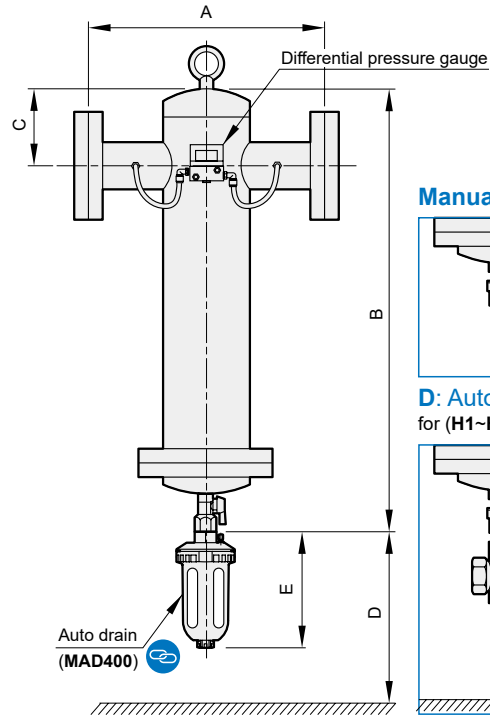

Manual drain

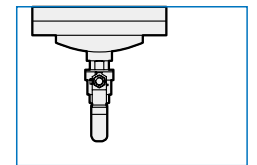

D: Auto drain (MAD400)
for (H1~H4) high pressure

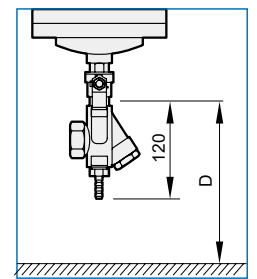

Model	Max. capacity		Connection	Dimension (mm)					N.W. kg	
	Nm ³ /min	SCFM		inch	A	B	C	D		E
MJF Series (Ported)	10F	1.6	56	Rc1/2"	87	303	24	380	200	1.3
	15F	2.4	84	Rc3/4"	87	303	24	380	200	1.3
	25F	3.6	127	Rc1"	130	325	43	390	200	3.6
	40F	5.5	194	Rc1 1/2"	130	325	43	390	200	3.6
	60F	8.1	285	Rc1 1/2"	130	740	43	630	200	6.7
	100F	15	529	Rc2"	163	762	55	790	200	8.9
	150F	25	882	Rc2 1/2"	163	1017	55	900	200	11.0
	10LP	1.6	56	Rc1/2"	200	395	75	250	200	-
	15LP	2.4	84	Rc3/4"	200	395	75	250	200	-
	25LP	3.6	127	Rc1"	280	410	93	250	200	-
	40LP	5.5	194	Rc1 1/2"	280	410	93	250	200	-
	60LP	8.1	285	Rc1 1/2"	280	790	93	450	200	-
	100LP	15	529	Rc2"	280	790	93	600	200	-
	150LP	25	882	Rc2 1/2"	300	1050	100	600	200	-
	MJL Series (Flanged)	200L	30	1059	3"FL	350	1120	116	680	200
400L		60	2118	4"FL	510	1330	150	680	200	70
700L		90	3177	6"FL	600	1450	195	680	200	110
900L		120	4236	6"FL	600	1460	195	680	200	150
1250L		150	5295	8"FL	750	1600	195	680	200	240

* Max. differential pressure: 0.6barG

* Element Replacement: Replace every 1 year or earlier if the differential pressure gauge changes to red. Activated carbon elements should be changed after 1000 hours operation. All filter elements only guaranteed under operating scope.

* Equip with "D" or "G". MJF series model number printed on name plate without -D-G, MJL series model number with -D-G



General description

- The Digital Condensation Removal Timer is a compact, modular timer valve combination specifically designed for air line condensation removal. This digital timer is compatible with MBS/MCS/MBD series valve size to obtain an optimal system.
- This device easily programmed by two press-keys and a LCD display.

Notes

- Timer is water and dust protected to IP65 when installed properly to a coil and connector with provided M3 screw.
- See manual for all operation options.

Specification

Valve type	Port size	Orifice (mm)
MBS-03	03(1/8)	1~2.4
MBS-06	06(1/4)	1~2.4
MCS-06	06(1/4)	1.6~10
MCS-10	10(3/8)	1.6~10
MCS-15	15(1/2)	1.6~10
MCS-20	20(3/4)	1.6~10
MBD-06	06(1/4)	1.6~3.5
MBD-09	09(3/8)	1.6~3.5
MBD-10	10(3/8)	2.5~5.5
MBD-15	15(1/2)	2.5~5.5

Order example

MBS-03-2-J-3-D-AC110-Y-T

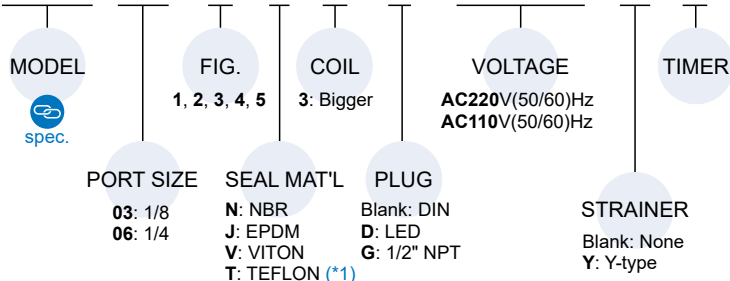

MCS-06-2-J-5-D-AC110-Y-T

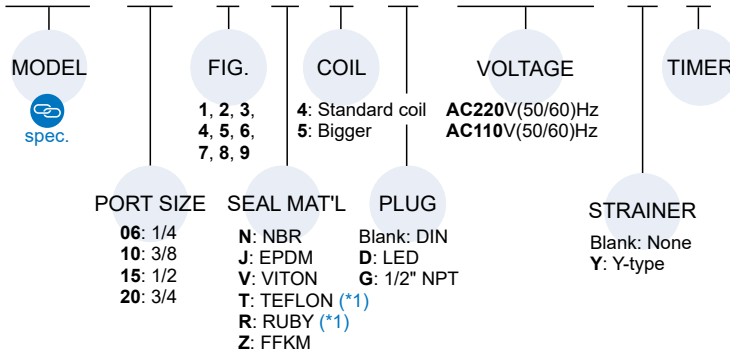

*1. When the seal material is (T) Teflon or (R) RUBY, the valve has slight leakage, not suitable for vacuum.

MBD-06-2-V-3-D-AC110-Y-T

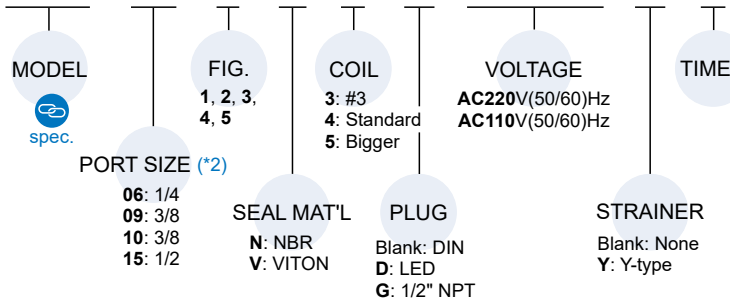

*2. Port size (06) and (09) can only apply with coil No.3.
Port size (10) and (15) can only apply with coil No.4 and No.5.

Time adjustment

Time ranges: OFF 0~99 mins.
ON 0~59 sec.

Digital display

Count down ON and OFF times.

Reset timing: Press both buttons simultaneously for 2 seconds (Reset timing only. Settings will remain the same.)

1. Press SET for 2 seconds
2. Press ADJ to adjust ON time
3. Press SET
4. Press ADJ to adjust OFF time
5. Press SET
6. Press ADJ to adjust OFF time minutes
7. Press SET

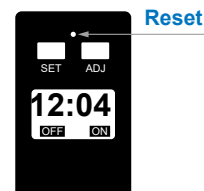

Installation

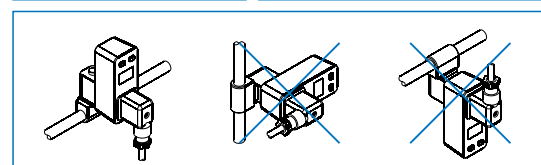
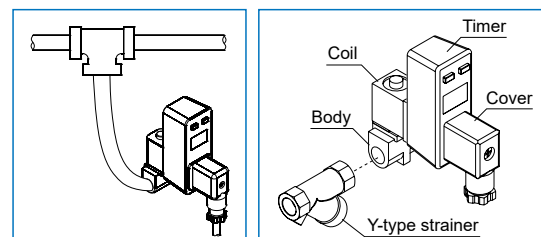



Features



Circuit example



Energy saving



Caution for safety
(Read before installing)



Symbol

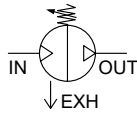

Order example

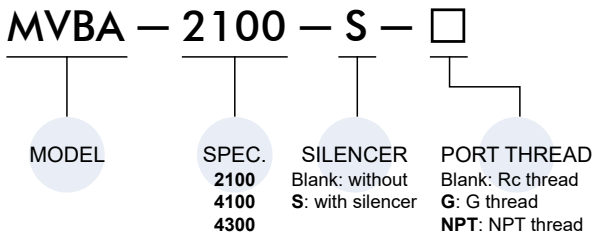

Working Principle

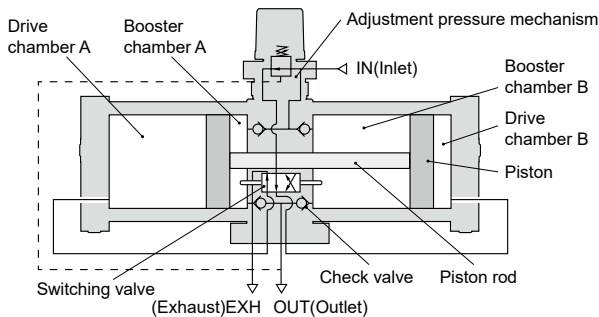

- The IN(Inlet) air passes through the check valve to booster chamber A and B. Meanwhile, air is supplied to drive chamber B via the governor and the switching valve. Then, the air pressure from drive chamber B and booster chamber A are applied to the piston, boosting the air in booster chamber B. As the piston travels, the boosted air is pushed via the check valve to the OUT(Outlet) side. When the piston reaches the switching valve to touch, so that drive chamber B is in the exhaust state and drive chamber A is in the supply state respectively. Then, the piston reverses its movement, this time, the pressures from booster chamber B and drive chamber A boosts the air in booster chamber A and sends it to the OUT side.
- The process described above is repeated to continuously supply highly pressurized air from the IN to the OUT side. The governor establishes the outlet pressure by handle operation and pressure adjustment in the drive chamber by feeding back the outlet pressure.

Features

- Increase factory air pressure by up to twice as much.
- Air-only operation requires no power supply, reduces heat generation, and allows easy installation.

Specification

Model	MVBA-2100	MVBA-4100	MVBA-4300
Port size (IN, OUT, EXH) (*1)	3/8	1/2	1/2
Gauge port (IN, OUT) (*1)	1/16	1/8	1/8
Air tank port (*1)	1/4	1/2	1/2
Medium	Compressed air		
Pressure increase rate	Maximum of twice		
Operating pressure range (*2)	0.2~1 MPa		0.2~1.6 MPa
Supply pressure range	0.1~1 MPa		
Proof pressure	1.5 MPa		2.4 MPa
Max. flow rate (*3)	1000 ℓ/min	1600 ℓ/min	
Ambient temperature	+2~+50°C (No freezing)		
Installation	Horizontal		
Lubrication	Not required		
Attachment: Pressure gauge	PG-25	PG-40W	PG-40W-20K
Option: Silencer (S)	MSLT-03	MSLT-04	
Suitable for air tank (Please refer to the MVBAT series) 	MVBAT10A	MVBAT21C	MVBAT22HC
	MVBAT20A		
	MVBAT21B		
Weight (kg)	3.9	9.4	9.5

*1. Thread type combination

Model	Port thread	Gauge thread	Air tank thread
MVBA-2100	Rc, G, NPT	Rc	Rc
MVBA-4100	Rc, G	Rc	Rc
MVBA-4300	NPT	NPT	Rc

*2. Do not adjust the pressure beyond the maximum specified pressure range.

*3. Max. flow rate at IN=OUT=0.5 MPa.

*4. Attachment and optional accessories are included with the shipment separately and are not pre-assembled.

Caution

- If the outlet capacity is undersized, pulsation may occur.
- Make sure to install a mist separator at the inlet side of the booster regulator.
- The booster regulator has a sliding part inside, and it generates dust. Also, install a cleaning device such as an air filter or a mist separator on the outlet side as necessary.
- Provide a dedicated pipe to release the exhaust air from each booster regulator. If exhaust air is converged into a pipe, the back pressure that is created could cause improper operation.
- Depending on the necessity, install a silencer on the exhaust port of the booster regulator to reduce the exhaustion sound.
- Allow the sufficient space for maintenance and inspection.

Example of circuit usage

- In factories where only specific equipment requires high pressure, a booster cylinder can be installed in the corresponding local air circuit. This allows the overall air circuit to maintain low pressure while enabling the use of high-pressure equipment in localized areas. This design not only reduces the pressure demand on the overall air circuit but also effectively saves energy and decreases the load on the equipment.

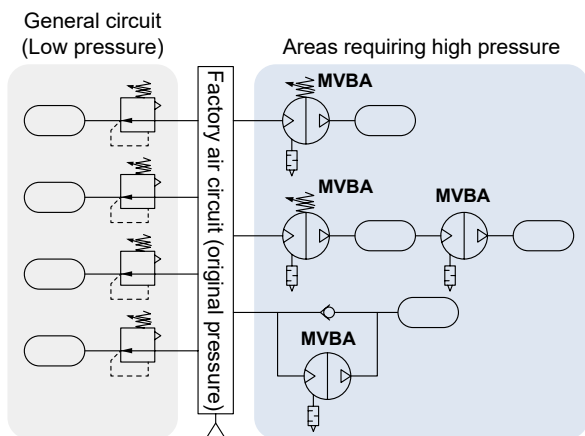

- When the actuator's output force is insufficient and spatial constraints prevent the use of a larger cylinder, a booster cylinder can be employed to increase output force without replacing the existing actuator.
- In cases where miniaturization of the drive component is required, and a small cylinder size is needed while maintaining a high output force, a booster cylinder offers an effective solution.

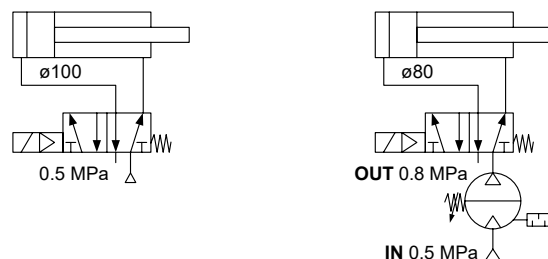

Operating Pressure	0.5 MPa
Tube I.D.	ø100 mm
Output Force	3850 N

Equivalent output force

Operating Pressure	0.8 MPa
Tube I.D.	ø80 mm
Output Force	4000 N

- When using two booster cylinders for two-stage boosting, ensure that each booster cylinder is supplied with sufficient airflow to maintain the stability of the inlet pressure at the booster valve. This is critical for ensuring the stability and efficiency of the boosting process.

- During the process of charging the air tank, a circuit design incorporating a booster cylinder in parallel with a check valve is used. When the pressure in the air tank is lower than the inlet air source pressure, the air source directly charges the tank through the check valve. This method efficiently utilizes the air source pressure, reducing the charging time and improving overall efficiency.

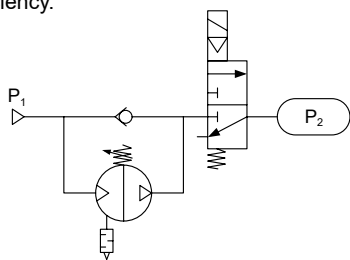

The inlet pressure (P_1) first passes through a check valve to charge P_2 until $P_1=P_2$.

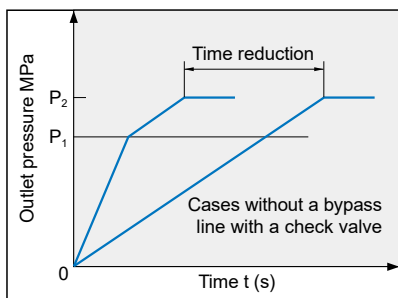

- For single-acting cylinder operations, installing a booster cylinder in the corresponding air supply circuit can reduce compressed air consumption, achieving more efficient operation.

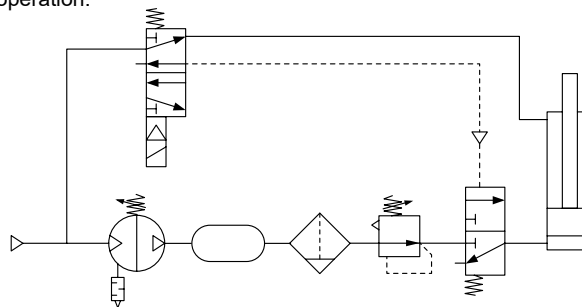

Flow features

MVBA-2100

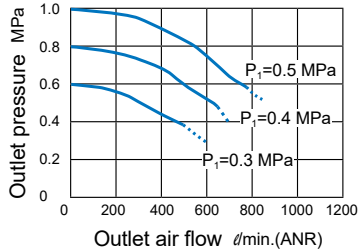

MVBA-4100

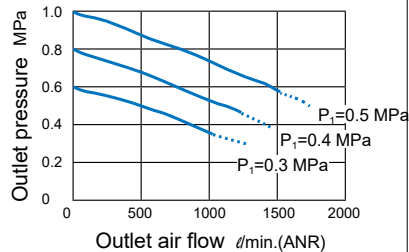

MVBA-4300

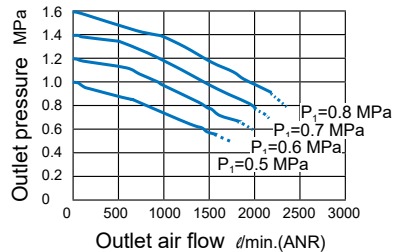

Pressure characteristics

Inlet pressure 0.7 MPa
Output pressure 1.0 MPa
Flow rate: 20L/min(ANR)

MVBA-2100

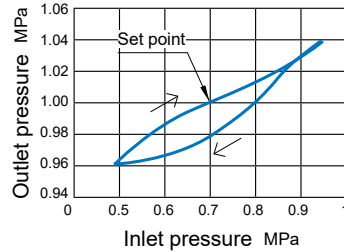

Inlet pressure 0.7 MPa
Output pressure 1.0 MPa
Flow rate: 20L/min(ANR)

MVBA-4100

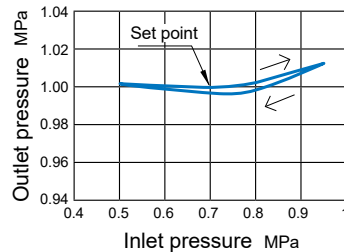

Inlet pressure 0.7 MPa
Output pressure 1.0 MPa
Flow rate: 20L/min(ANR)

MVBA-4300

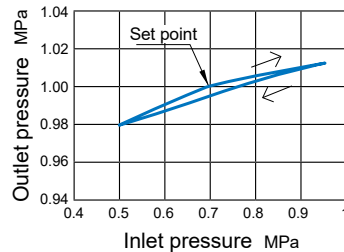

Charge test

MVBA-2100

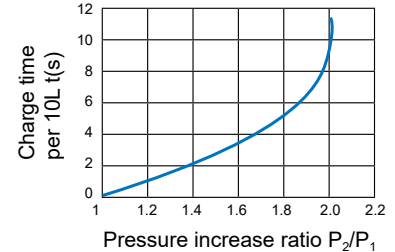

MVBA-4100

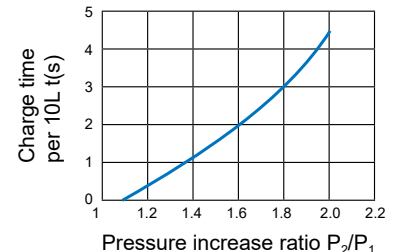

MVBA-4300

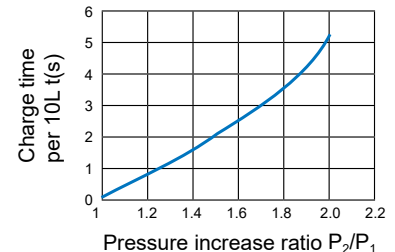

Calculation method for air tank charge time

P_0	Primary side air pressure
P_1	Air pressure in tank before filling
P_2	Air pressure in tank after filling
$K_1=P_1/P_0$	Boosting ratio before filling
$K_2=P_2/P_0$	Boosting ratio after filling

Find K_1 and K_2 at first, then read filling time t_1 and t_2 according to graph where boosting ratio K_1 , K_2 . Finally filling time for tank capacity Q is obtained with

$$T = \frac{Q}{10} (t_2 - t_1).$$

(Each characteristics are just reference, but not assured conditions)

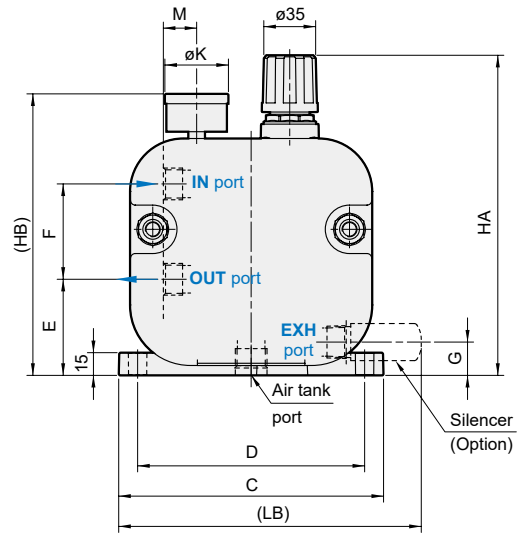
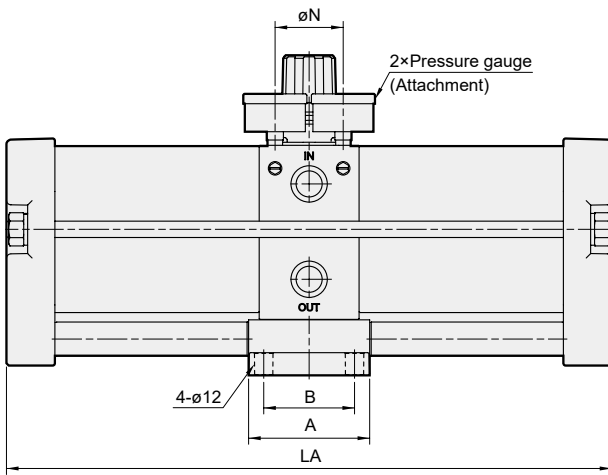
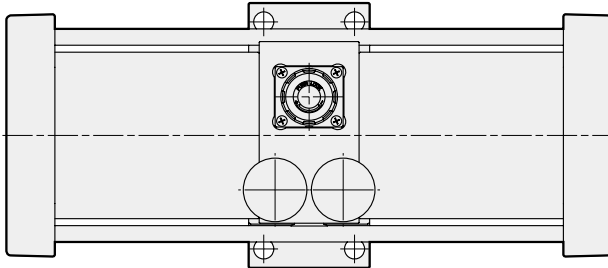

Back

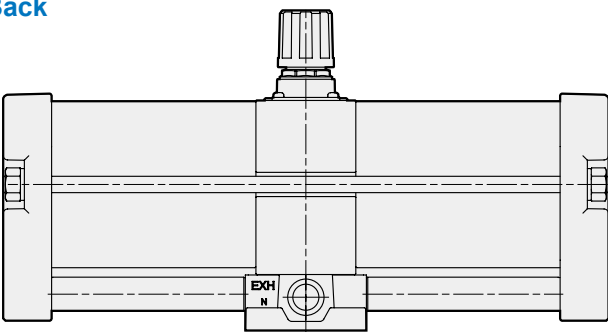

Code Model	A	B	C	D	E	F	G	HA	HB	LA	LB	K	M	N
MVBA-2100	73	53	118	98	46	43	18	172.5	140	295	168	24	8	30
MVBA-4100	80	60	175	150	63.5	63	22	211.5	186	400	200	42	22	45
MVBA-4300								221.8						



Features



Circuit example



Energy saving



Caution for safety
(Read before installing)

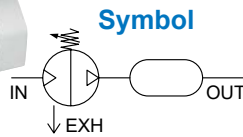

Features

- Increase the primary pressure in the air line up to twice.
- Air-only operation requires no power supply, reduces heat generation, and allows easy installation.

Caution

- If the outlet capacity is undersized, pulsation may occur.
- Make sure to install a mist separator (0.3 μ m) at the inlet side of the booster regulator.
- The booster regulator has a sliding part inside, and it generates dust. Also, install a cleaning device such as an air filter or a mist separator on the outlet side as necessary.
- Provide a dedicated pipe to release the exhaust air from each booster regulator. If exhaust air is converged into a pipe, the back pressure that is created could cause improper operation.
- Depending on the necessity, install a silencer on the exhaust port of the booster regulator to reduce the exhaustion sound.
- Sufficient space for maintenance and inspection is suggested.

Specification

Model	MVBAT1021	MVBAT2021	MVBAT2121	MVBAT2141	MVBAT22H43
Medium	Compressed air				
Operating pressure range	0.2~1 MPa				0.2~1.6 MPa
Supply pressure range	0.1~1 MPa				
Ambient temperature	+2~+50°C (No freezing)				
Attachment (*3) Pressure gauge	PG-25		PG-40W		PG-40W-20K
Option (*3)	A: Precision filter regulator		A-BA-03		A-BA-04
	S: Silencer		MSLT-03		MSLT-04
	V: Drain valve & piping joint		V-BA-02		
Weight (Booster regulator with air tank) (kg)	12	20	18.5	24	34
Booster regulator (*1)					
Applicable model	MVBA-2100			MVBA-4100	MVBA-4300
IN, OUT, EXH port	Rc3/8		Rc1/2		
Air tank (*2)					
Applicable model	MVBAT10A	MVBAT20A	MVBAT21B	MVBAT21C	MVBAT22HC
OUT port size	Rc3/8		Rc1/2		
IN port size	No port thread provided				
Safety valve square port	-				Rc3/8
Drain valve port	Rc1/4				
Max. operating pressure MPa	1.15	1.5	1		2
Proof pressure MPa	1.725	2.25	1.6		3.3
Ambient & operating fluid temperature	0~+75°C				
Volume (L)	10	20	20		
Material	Carbon steel				
Painting	Exterior: Cool gray-white baked paint				
	Interior: No anti-rust coating				
Weight (kg)	8	16	14.5	14.5	24.5

*1. When selecting option A (precision filter regulator), the booster will use Rc thread specification exclusively. Refer to "MVBA series spec.".

*2. Not recommended for use solely as an air tank. Only Rc threading is available. For those opting for G or NPT threading, one male-to-female OUT port adapter (1 pc) is included as needed.

*3. Drain valves and precision filter regulator are assembled for shipment. Attachment and optional accessories are included with the shipment separately and are not pre-assembled.

BOOSTER REGULATOR WITH AIR TANK

Order example

MVBAT 10 21 — □ — G

MODEL

PORT THREAD
Blank: Rc thread
G: G thread
NPT: NPT thread

Tank internal capacity		Booster regulator	
10	10L	21	2100
20	20L		
21	20L	41	4100
	20L		
22H	20L	43	4300

OPTIONAL
Blank: without
A: Precision filter regulator
S: Silencer
V: Drain valve

Dimensions

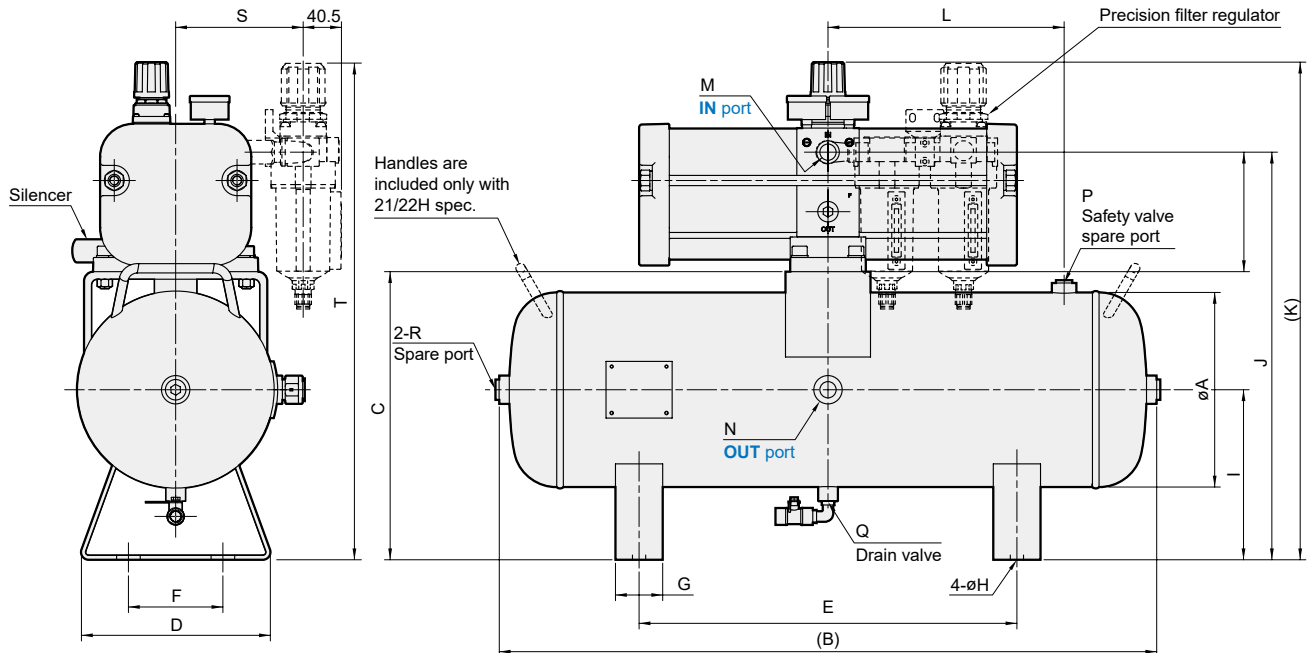

Code Model	A	B	C	D	E	F	G	H	I	J	K	L	M	N	P	Q	R	S	T	
MVBAT 1021	200	407	300	200	180	125	25	10	160	389	473		Rc3/8	Rc3/8			Rc3/8		483	
MVBAT 2021	244~248	515								429	513		Rc3/8	Rc3/8			Rc3/8	115	523	
MVBAT 2121	244	512	340	250	270	155	38	14	180	466.5	551.5		Rc1/2	Rc1/2		Rc1/4	Rc1/2		135	560.5
MVBAT 2141																				525.5
MVBAT 22H43	206	696	305	200	400	155	50	14		431.5	527	250			Rc3/8					525.5



Caution for safety
(Read before installing)



Features

- Generates high pressure by use of high pressure hydraulic fluid.
- Universal design enables unit to be used in a wide variety of applications.
- Ideal for providing the motive force for marking, punching, shearing, straightening, embossing and welding.

Single pressure booster

Optimum for high output, short stroke cylinder.

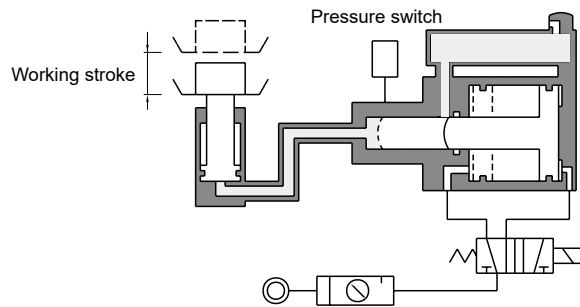

MHBS Single pressure type

MHBD Dual pressure type

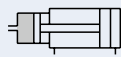

Specification

Model	Single pressure type			Dual pressure type		
	MHBS-078	MHBS-110	MHBS-250	MHBD-078	MHBD-110	MHBD-250
Intensified pressure ratio	7.8	11	25	7.8	11	25
Generated hydraulic pressure (MPa)	5.3	7.6	17.2	5.3	7.6	17.2
Discharging volume (cc)	50	120	120	50	120	120
Port size	Rc3/8	Rc1/2	Rc1/2	Rc3/8	Rc1/2	Rc1/2
Ambient temperature	+5~+60 °C					
Operating pressure range	0.2~0.7 MPa					
Driving fluid	Hydraulic work oil viscosity					
Mounting form	Side foot type					
Sensor switch	LN02A	LN03A		LN02A	LN03A	

Order example

MHBD - 110

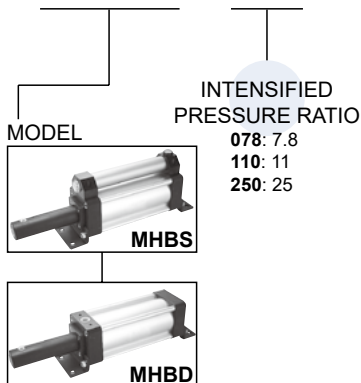

The method of calculation (Booster consumption)

$$A = (D)^2 \times \frac{\pi}{4} \text{ mm}^2$$

$$P2 = R \times P$$

$$F = A \times P2 = \text{___ N}$$

A:	Piston area	(mm ²)
D:	Piston I.D.	(mm)
F:	Cylinders force	(N)
P:	Air pressure	(MPa)
P2:	Intensified pressure	(MPa)
R:	Intensified pressure ratio	

Dual pressure booster

Booster precautions

- The booster must be levelled.
- Standard booster are designed for use with petroleum base hydraulic oil.
- The booster must be higher than the work hydraulic cylinder.
- Frequency of use should be 6 times/min or lower.

1. Quick traverse

2. Intensified feeding

3. Swift reverse

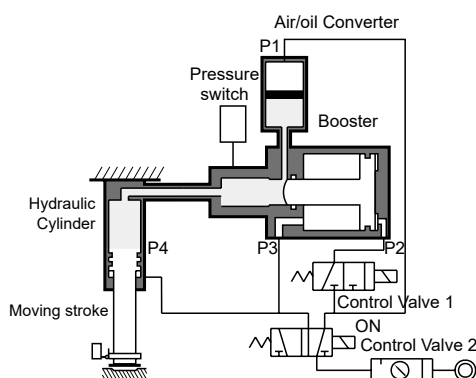

When the air enters through port P1, the oil in the air/oil converter is pushed into the hydraulic cylinder in large quantities and quickly. The pressure is the same as the air pressure.

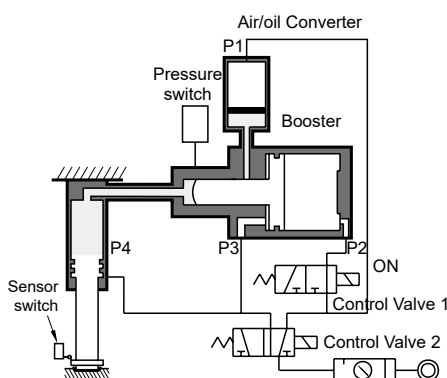

When the air enters through port P2, the piston advances and pushes the high pressure oil into the hydraulic cylinder.

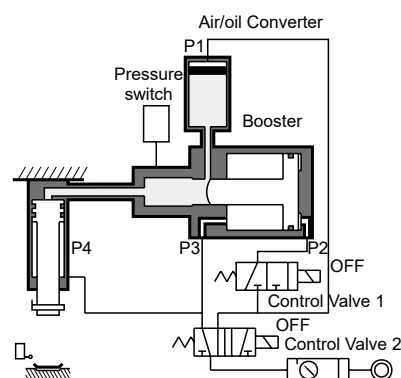

When the air enters through ports P4 and P3, the hydraulic cylinder and Booster return to their original position.

Compressed air consumption

l / cycle

Boosters	Operating pressure (MPa)					
	0.2	0.3	0.4	0.5	0.6	0.7
MHBS-078	2.40	3.19	3.98	4.78	5.56	6.36
MHBD-078	2.40	3.19	3.98	4.78	5.56	6.36
MHBS-110	7.58	10.07	12.57	15.07	17.57	20.06
MHBD-110	7.58	10.07	12.57	15.07	17.57	20.06
MHBS-250	18.09	24.06	30.02	35.99	41.95	47.92
MHBD-250	18.09	24.06	30.02	35.99	41.95	47.92

How to order the seal kit

Model	Code
MHBS-078	MHBSSK-078
MHBD-078	MHBDSK-078
MHBS-110	MHBSSK-110
MHBD-110	MHBDSK-110
MHBS-250	MHBSSK-250
MHBD-250	MHBDSK-250

Installation of sensor switch

Model	Sensor switch
MHBS(D)-078	LN02A
MHBS(D)-110	LN03A
MHBS(D)-250	LN03A

Booster weight

Unit: kg

Type	MHBS	MHBD
	078	3.4
110	10.1	9.1
250	20.0	18.0

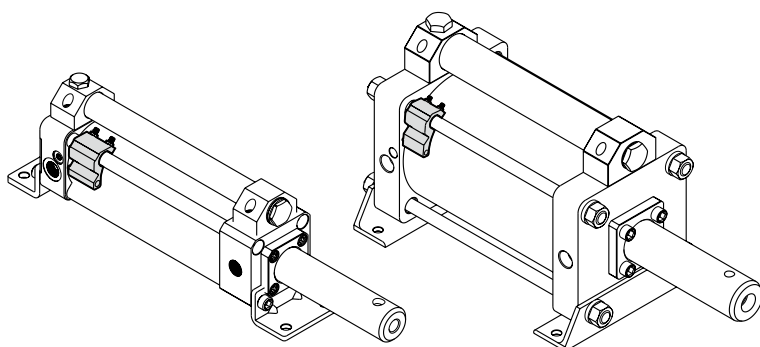

MHBS-078

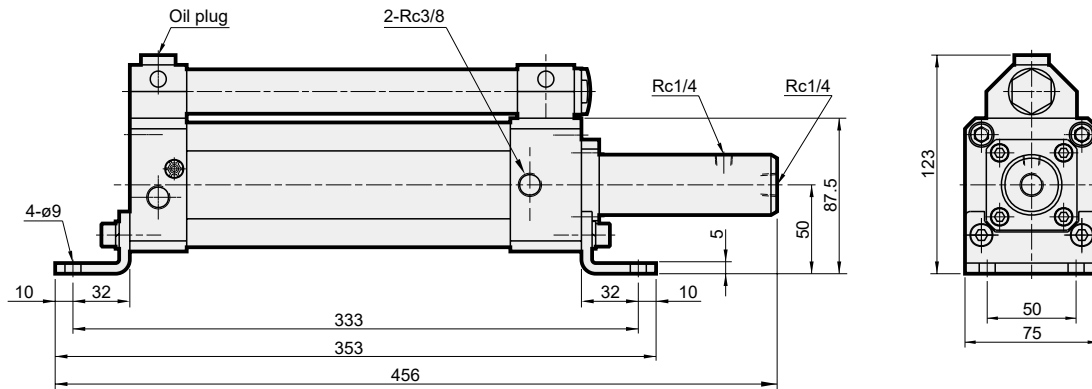

MHBS-110

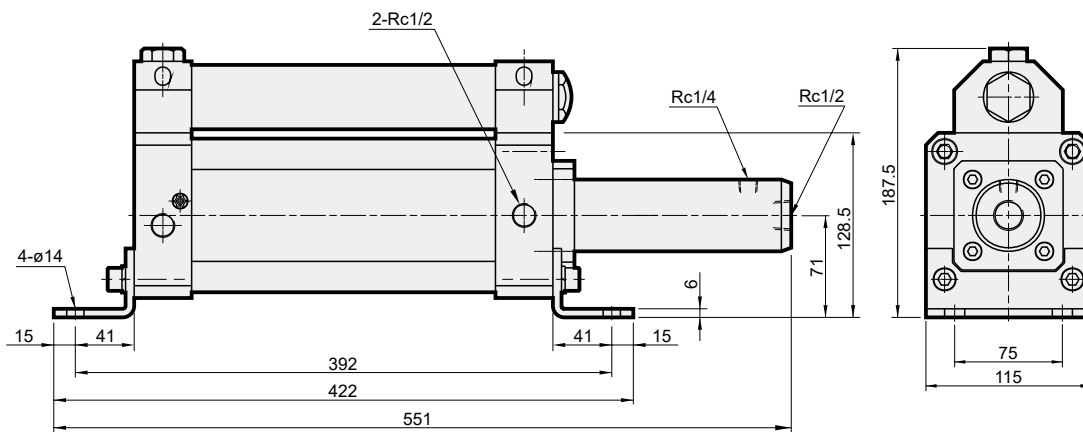

MHBS-250

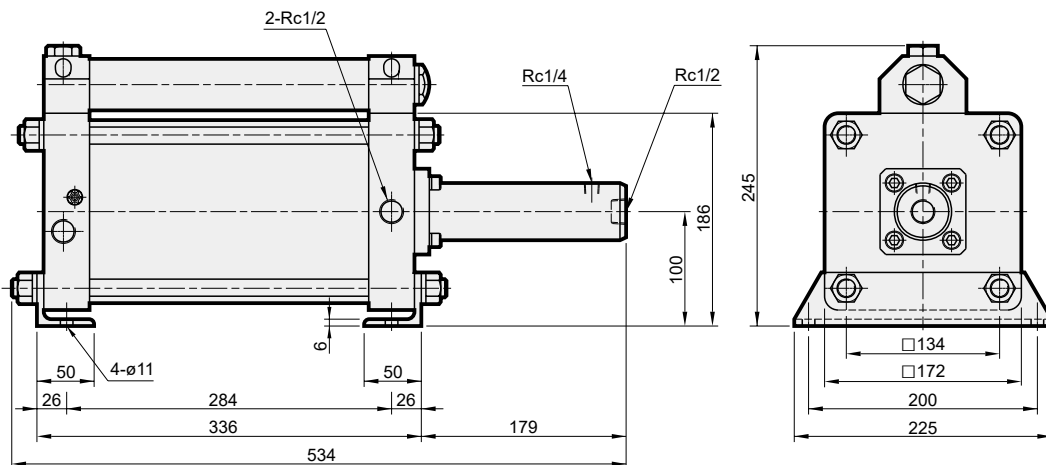

MHBD Dimensions – Dual pressure type

BOOSTER



MHBD-078

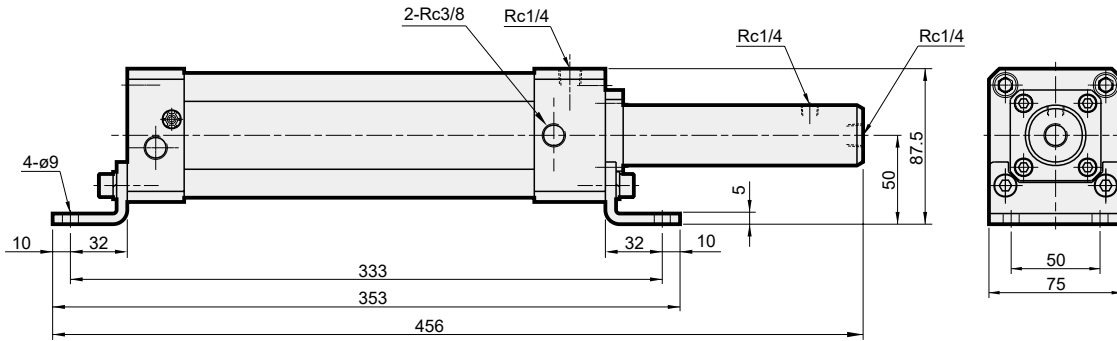

MHBD-110

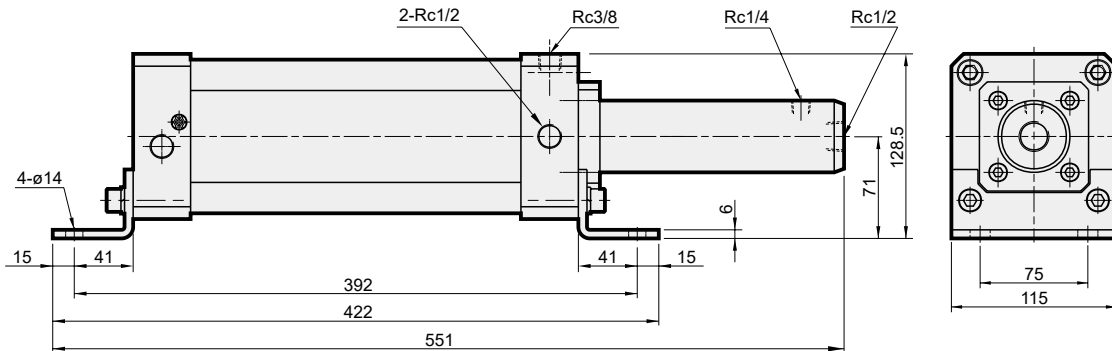

MHBD-250

