

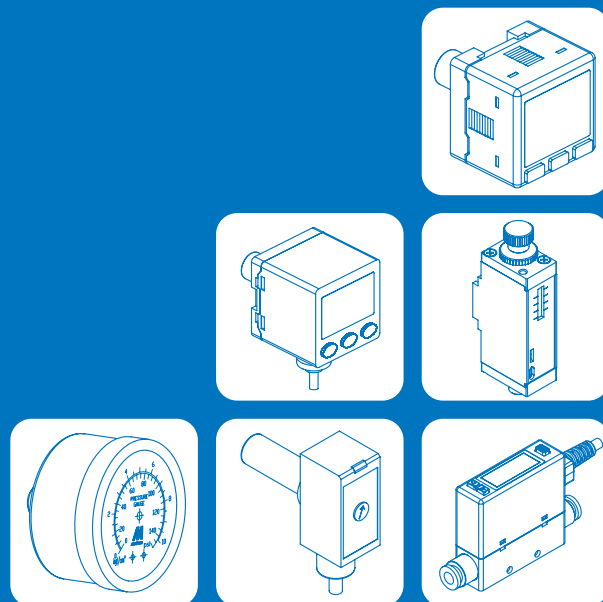

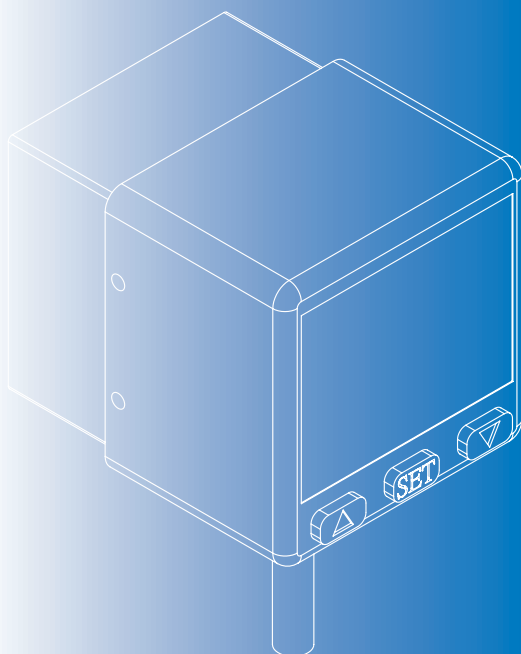







PRESSURE & FLOW SWITCH



	Selector Table	5-2
	PNEUMATIC PRESSURE SWITCH	
MP*	MP10	5-8
	MP30	5-11
	MP41	5-13
	MP48E New	5-19
	MP50/75	5-23
	MP90	5-28
	MPS	5-31
	DIFFERENTIAL PRESSURE SENSOR	
	MP800/7800	5-32
	MPDS	5-37
	GAP SENSOR	
	MPGS	5-41
	MULTI CONTROLLER	
	MP400	5-45

	DIGITAL FLOW SENSOR	
MF*	MF01/02	5-49
	FLOW & PRESSURE SENSOR	
	MFP01/02	5-56
	MFPS New	5-63
	FLOW SENSOR	
	MFS New	5-68
	DIGITAL PRESSURE GAUGE	
MPG	MPG-60	5-72
	PRESSURE GAUGE	
PG	PG	5-74
	PGV (for vacuum) New	5-75

Selector table ● Standard type ① Standard type (for MP41) ② Extra purchase (T8 bracket: Rc1/4 + Fitting: R1/4→Rc1/8)
 ③ Extra purchase (Gauge adapter set) ④ Extra purchase (Gauge adapter set + Fitting: R1/8→Rc1/4)

Model		Pneumatic pressure switch	High precision digital pressure switch					Pneumatic pressure switch	Digital pressure gauge	Pressure gauge	Vacuum pressure gauge
		MP10-F1	MP30	MP41	MP48E	MP50 MP75	MPS	MPG-60	PG	PGV	
Pictures											
Model	Port size	R1/8	R1/8	—	R1/8	R1/4	R1/8	R1/8	—	R1/8	
MACP200	Rc1/8				●			●	●		
MACP302	—	②	②	①	③	④	②	③	③		
MACP400	Rc1/4					●			●		
MACP401	—	②	②	①	③	④	●	③	③		
MACP402	Rc1/4					●					
MACP403	—	②	②	①	③	④	●	③	③		
MACP501	—	②	②	①	③	④	②	③	③		
MACT200	Rc1/8				●			●	●		
MACT302	—	②	②	①	③		②	③	③		
MACT400	Rc1/4					●			●		
MACT401	—	②	②	①	③	④	●	③	③		
MACT403	—	②	②	①	③	④	●	③	③		
MACT501	—	②	②	①	③	④	②	③	③		
MAFR200	Rc1/8				●			●	●		
MAFR302	—	②	②	①	③		②	③	③		
MAFR400	Rc1/4					●			●		
MAFR401	—			①	③			③	③		
MAFR403	—			①	③			③	③		
MAFR501	—			①	③			③	③		
MAR200	Rc1/8				●			●	●		
MAR302	—	②	②	①	③		②	③	③		
MARV302	Rc1/8				●					●	
MAR400	Rc1/4					●			●		
MAR401	—			①	③			③	③		
MAR403	—			①	③			③	③		
MAR501	—			①	③			③	③		

1 Standard type (for MP41)

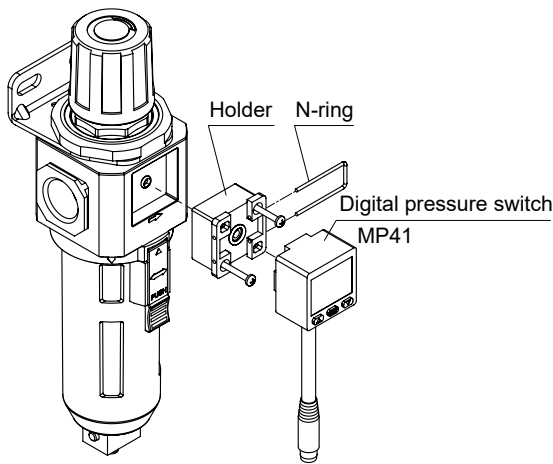

3 Extra purchase (Gauge adapter set)

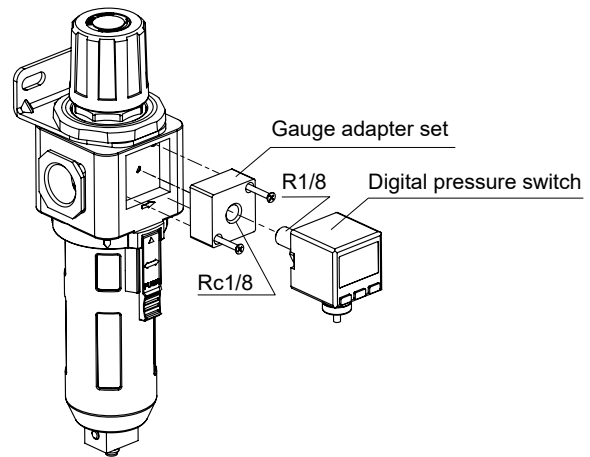

2 Extra purchase (T8 bracket + Fitting)

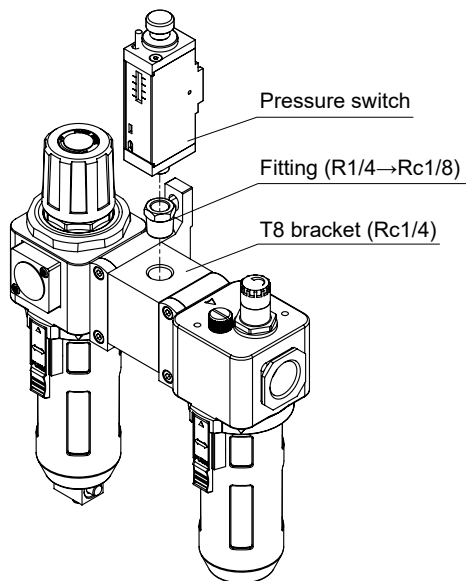

4 Extra purchase (Gauge adapter set + Fitting)

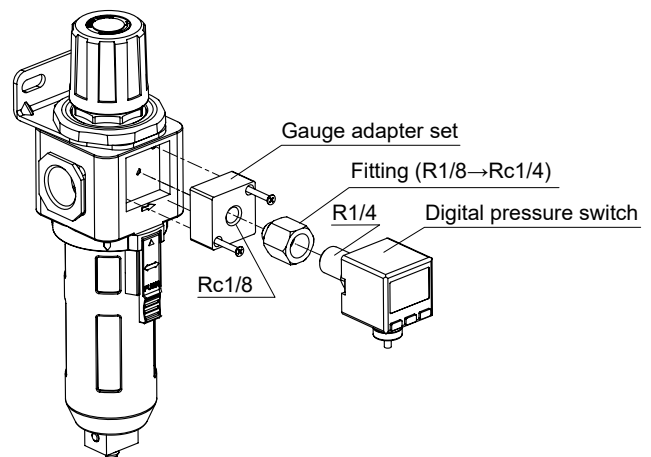

Order example of gauge adapter set

A — MAR302 — □

MODEL: MAR302, MAR401

PORT THREAD: Blank: Rc thread, NPT: NPT thread

Order example	Applicable model
A—MAR302—□	MAR302, MAFR302
A—MAR401—□	MAR401, MAFR401
A—MAR302—□ (Shared with 302)	MAR401-W, MAFR401-W MAR403, MAFR403 MAR501, MAFR501

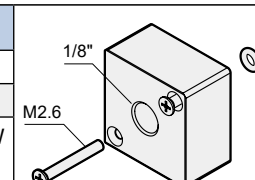

* Recommended tightening torque is between 1.5 to 2.5 Nm for the female thread (1/8") and 0.3 to 0.5Nm for the screws(M2.6).

Switch Accessories	MP10	MP30 MP41	MP48E	MP50 MP75	MP400	MP7800 MP800	MPG-60	MPDS MPGS	MF01 MFP01	MF02 MFP02	MFPS	MFS
MP-A5							●					
MP-A6							●					
MP-A8					●							
MP-A9					●							
MP-A10				●								
MP-A11				●								
MP-A18								●				
MP-A19								●				
MP-A20						●						
MP-A21						●						
MP-A22			●									
MP-A23			●									
MP-A26									●			
MP-A27										●		
MP-A28										●		
MP-A29											●	
MP-A30												●
MP-B2			●		●	●	●					
MP-B3				●				●				
MP-B4									●			
MP-C2			●		●	●	●					
MP-C3				●				●				
MP-C4									●			
MP-D1		●										
MP-D2	●											
MP-E1				●								
MP-E2				●								
MP-FA					●							
MP-FB					●							
MP-FC					●							

Model	Description
MP-A	Mounting bracket
MP-B	Panel adapter
MP-C	Panel adapter + Front protective lid
MP-D	M8,3(4) Pin female connector
MP-E	Snubber
MP-F	Sensor connector

Type	Model	Type	Model
Pressure switch	MP10	Differential pressure sensor	MP7800, MP800, MPDS
High precision digital pressure switch	MP30, MP41, MP48E, MP50, MP75	Digital pressure gauge	MPG-60
		Gap sensor	MPGS
		Flow sensor	MF01, MF02, MFS
Pressure controller	MP400	Flow & pressure sensor	MFP01, MFP02, MFPS

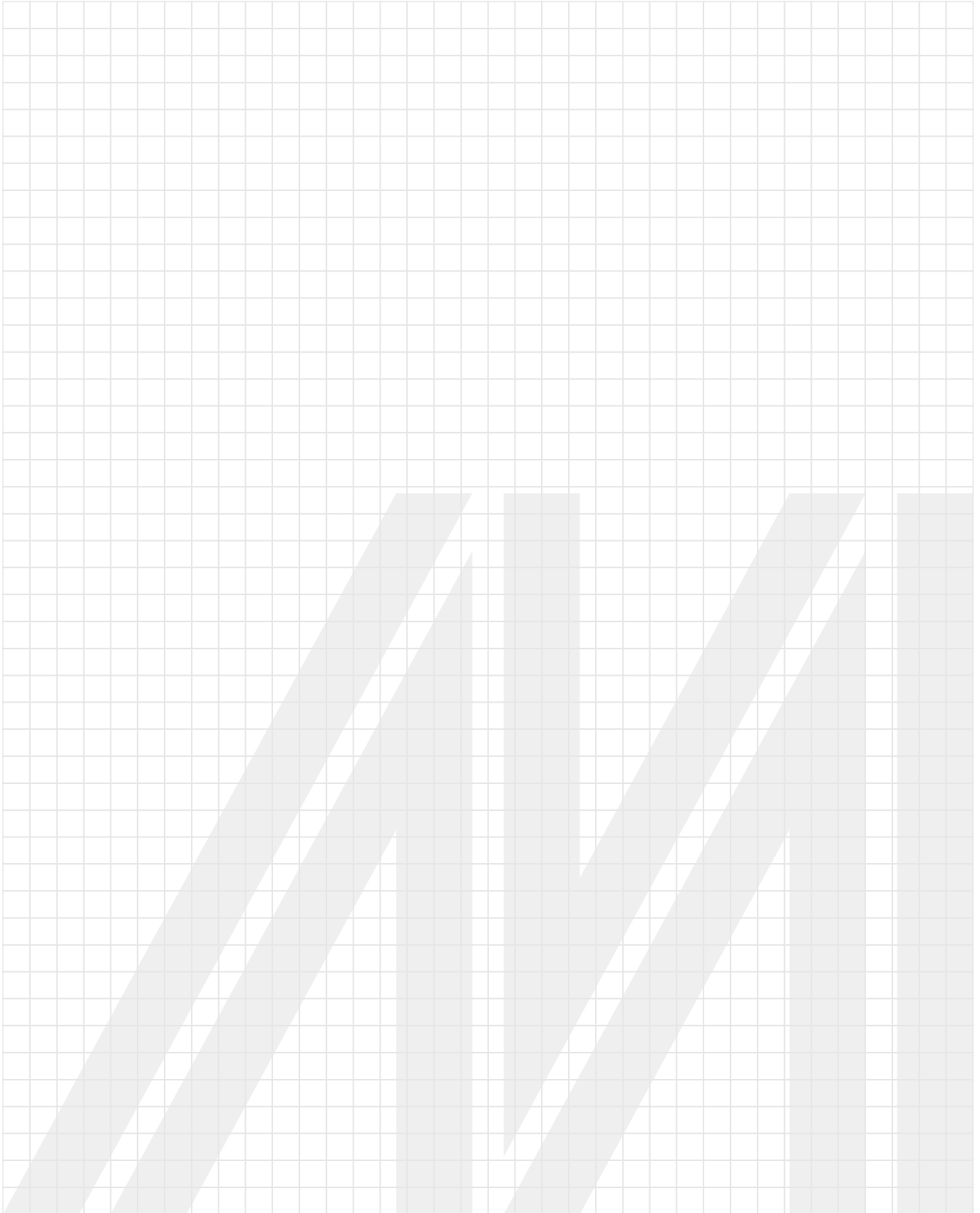

Selector table

Model	Flow rate range L/min										Flow direction	Output method	Working pressure range (kPa)	Port size	Fluid	Communication interface	
	Code	-10	0	5	10	50	100	200	500	1000							2000
Digital flow sensor MF01	005											Unidirection	010: 2 NPN output + 1 Analog output (1~5V) 011: 2 NPN output + 1 Analog output (4~20mA) 02 : 2 NPN output + RS485 030: 2 PNP output + 1 Analog output (1~5V) 031: 2 PNP output + 1 Analog output (4~20mA) 04 : 2 PNP output + RS485	-	ø6, Rc1/8	Dry air, N ₂ , Non-corrosive / Non-flammable gas	RS485 Modbus RTU
	010																
	050																
	100																
	500																
	101																
	201																
	501																
	102																
	202																
Digital flow sensor MFS	003										Unidirection	01: 1 Analog output (1 ~ 5V)	-	M5, bottom mounting (None thread)	Dry air, N ₂ , Non-corrosive / Non-flammable gas	-	
	005																
	010																
	050																
	100																
	R003																
	R005																
	R010																
	R050																
	R100																
Digital flow & pressure sensor MFP01	005										Unidirection	010: 2 NPN output + 1 Analog output (1~5V) 011: 2 NPN output + 1 Analog output (4~20mA) 02 : 2 NPN output + RS485 030: 2 PNP output + 1 Analog output (1~5V) 031: 2 PNP output + 1 Analog output (4~20mA) 04 : 2 PNP output + RS485	-90 ~ 800	ø6, Rc1/8	Dry air, N ₂ , Non-corrosive / Non-flammable gas	RS485 Modbus RTU	
	010																
	050																
	100																
	500																
	101																
	201																
	501																
	102																
	202																
Digital flow & pressure sensor MFPS	003										Unidirection	01: 2 Analog output (1 ~ 5V)	-100 ~ 200	M5, bottom mounting (None thread)	Dry air, N ₂ , Non-corrosive / Non-flammable gas	-	
	005																
	010																
	050																
	100																
	R003																
	R005																
	R010																
	R050																
	R100																

MP10 series

PNEUMATIC PRESSURE SWITCH



User manual



Selection table



Symbol

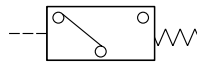

Features

- Simple installation, plug-in port or thread-in fitting.
- Compact size: 26×10×10.4 mm.
- Setting pressure range.
 - Switch: Vacuum (0~ -101.3 kPa)
 - Positive (0~0.6 MPa)
 - Analog: Compound (-100~100 kPa)
 - Compound (-101~500 kPa)
 - Low (0~100 kPa)
 - Vacuum (0~-101.3 kPa)
 - Positive (0~1.0 MPa)
- Low cost.

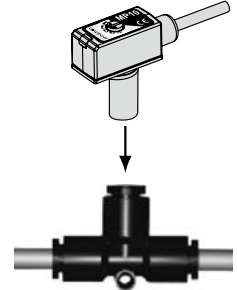

Specification

Model	MP10C	MP10L	MP10V	MP10R	MP10P	MP10V	MP10P	MP10A	MP10B
Output method	01					02 / 04		-	
Type	Analog					Switch		-	
Setting pressure range	-100~100 kPa	0~100 kPa	-101.3~0 kPa	-101~500 kPa	0~1.0 MPa	-101.3~0 kPa	0~0.6 MPa	-0.1~0.6 MPa	
Withstand pressure	0.2 MPa			1.5 MPa		0.6 MPa	1.5 MPa	1.5 MPa	
Fluid	Filtered air, Non-corrosive / Non-flammable gas								
Power supply voltage	12 to 24V DC (5% ripple voltage)					10.8 to 30V DC (include ripple voltage)		12 to 24V DC±10% Ripple(P-P) 10% or less	
Load / Leak current	-					80mA max. (Load)		5~40mA / ≤ 1mA	
Internal voltage drop	-					≤ 0.8V		≤ 5V	
Current consumption	10mA max.					-		-	
Analog output	1~5V ± 1% F.S. / Linearity ± 0.5% F.S.					-		-	
Sensor type	-					NPN or PNP		Present press. ≥ Set press.: ON Present press. < Set press.: OFF	
Output short circuit protection	-					Yes		None	
Setting method	-					Adjusting by VR			
Response time	-					Approx. 1ms			
Repeatability	-					±1% F.S.			
Hysteresis	-					≤ 3% F.S. max.		≤ 4% F.S.	
Indicator	-					Red LED turns ON			
Enclosure	IP 40								
Temperature characteristic	≤±2% F.S. of detected pressure (25°C) at temp. Range of 0~50°C					≤±3% F.S. of detected pressure (25°C) at temp. Range of 0~50°C			
Ambient temp. range	Operation: 0 ~ 50°C, storage: -20 ~70°C (No condensation or freezing)					Operation: 0 ~ 60°C, storage: -20 ~70°C (No condensation or freezing)			
Ambient humidity range	Operation / Storage: 35~85% RH (No condensation)								
Vibration	Total amplitude 1.5mm or 10G, 10Hz-55Hz-10Hz scan for 1 minute, two hours each direction of X, Y and Z								
Shock	980m/s ² (100G), 3 times each in direction of X, Y and Z								
Port size	ø4mm, ø6mm, R1/8, NPT1/8, G1/8, M5								
Lead wire	Oil-resistance cable, 3 wires (0.18mm ²), ø2.6mm							Oil-resistance cable, 2 wires (0.18mm ²), ø2.6mm	
Weight	Approx. 50 g (with 3 meter lead wire)								

Circuit wiring diagram

MP10□-01

Analog Output (1~5V)

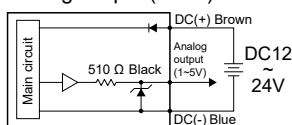

MP10□-02/04

NPN

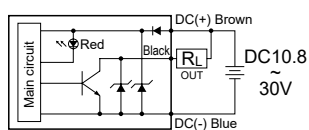

PNP

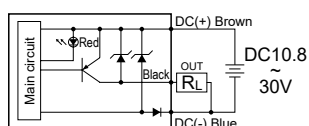

MP10A / MP10B

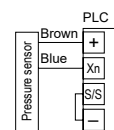
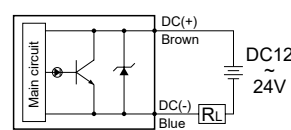

Connection to PNP input module

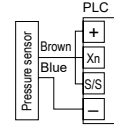
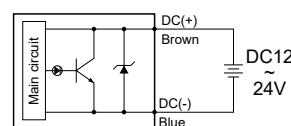

Connection to NPN input module

Installation precautions

- When mounting, always use the wrench on the metallic area near the pressure port. Never apply a wrench to the plastic body, it will damage the sensor.
- Over tightening may cause damages to the port thread, mounting bracket and pressure sensor. Under tightening may result loosen or leakage.
- Apply pressure and power after installation and make necessary adjustments and inspect any possible signs of leakage to ensure proper installation.

How to set pressure

- Use the pressure setting trimmer to set "ON" pressure. Rotate clockwise to increase pressure setpoint. Rotate counter-clockwise to decrease pressure setpoint.
- Use appropriate size screwdriver for the setting trimmers. Gently turn the screwdriver to make adjustments. To prevent damage to the Pressure setting trimmer, DO NOT force the trimmer when it comes to a stop.

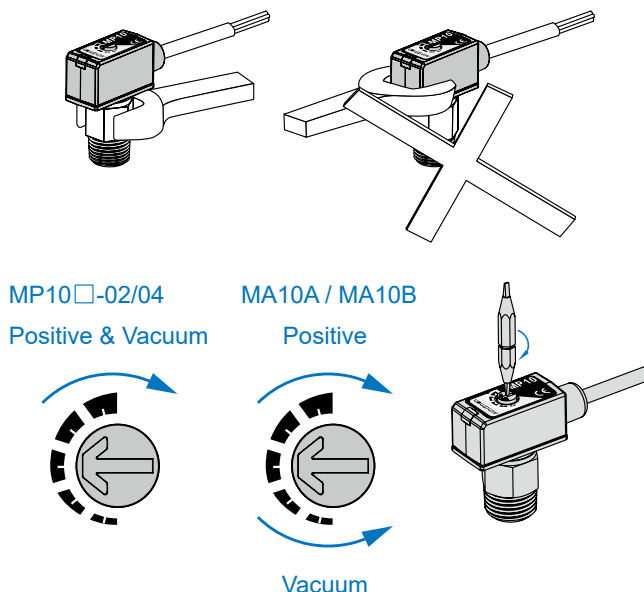

Order example

MP10P - 01 - R4 - □

MODEL	PRESSURE RANGE	OUTPUT METHOD	CABLE LENGTH / CONNECTOR	PRESSURE PORT															
MP10P - 01 - R4 - □	C: Compound (-100~100 kPa)	01: Analog output (1~5V)	Blank: With 3 meter cable C: With M8, 3 Pin male connector	<table border="1"> <thead> <tr> <th></th> <th>R4</th> <th>R6</th> <th>F1 / F2 / F3</th> <th>M5</th> </tr> </thead> <tbody> <tr> <td>Drawing</td> <td></td> <td></td> <td></td> <td></td> </tr> <tr> <td>Port size</td> <td>R4: ø4mm</td> <td>R6: ø6mm</td> <td>F1: R1/8", M5×0.8 F2: NPT1/8", M5×0.8 F3: G1/8", M5×0.8</td> <td>M5: M5×0.8</td> </tr> </tbody> </table>		R4	R6	F1 / F2 / F3	M5	Drawing					Port size	R4: ø4mm	R6: ø6mm	F1: R1/8", M5×0.8 F2: NPT1/8", M5×0.8 F3: G1/8", M5×0.8	M5: M5×0.8
					R4	R6	F1 / F2 / F3	M5											
	Drawing																		
	Port size				R4: ø4mm	R6: ø6mm	F1: R1/8", M5×0.8 F2: NPT1/8", M5×0.8 F3: G1/8", M5×0.8	M5: M5×0.8											
	R: Compound (-101~500 kPa)																		
	L: Low (0~100 kPa)																		
	V: Vacuum (0~ -101.3 kPa)																		
	P: Positive (0~1.0 MPa)	02: NPN output 04: PNP output																	
V: Vacuum (0~ -101.3 kPa)																			
P: Positive (0~0.6 MPa)																			
A: Switch turns ON when the pressure is larger than setting pressure																			
B: Switch turns OFF when the pressure is larger than setting pressure.	-	-																	

Output type

MP10□-01 Analog Output (1~5V)

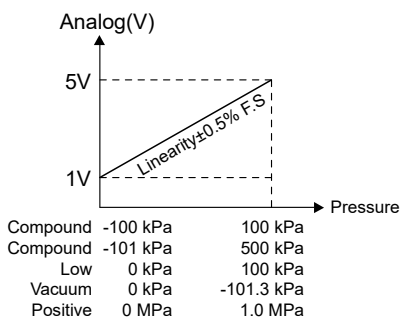

MP10□-02/04

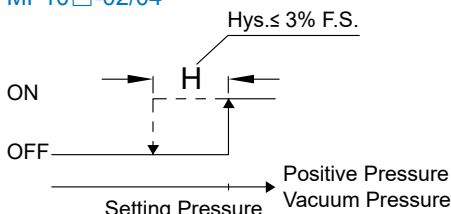

MP10A

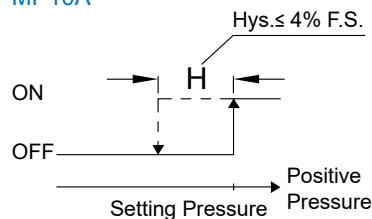

MP10B

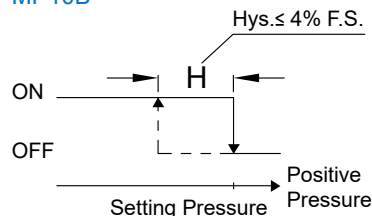

Dimensions

MP10□-02/04 / MA10A / MA10B

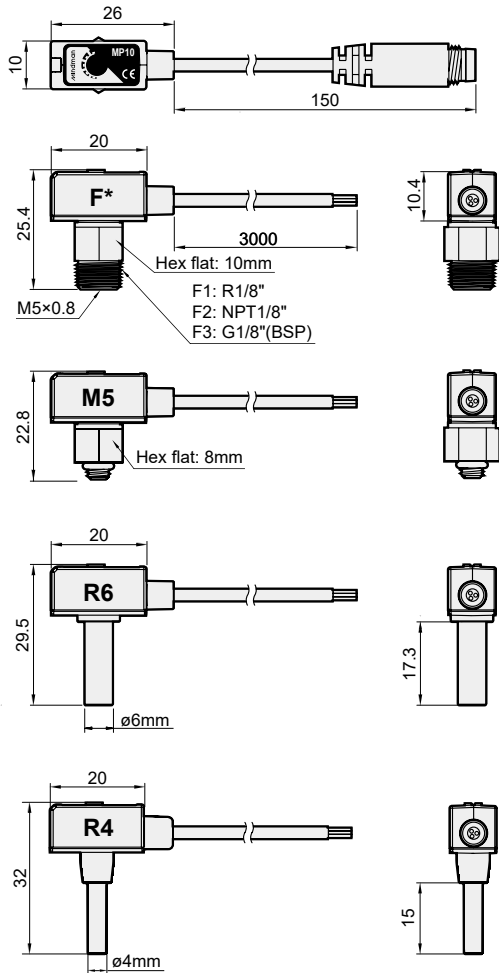

MP10□-01

Unit: mm

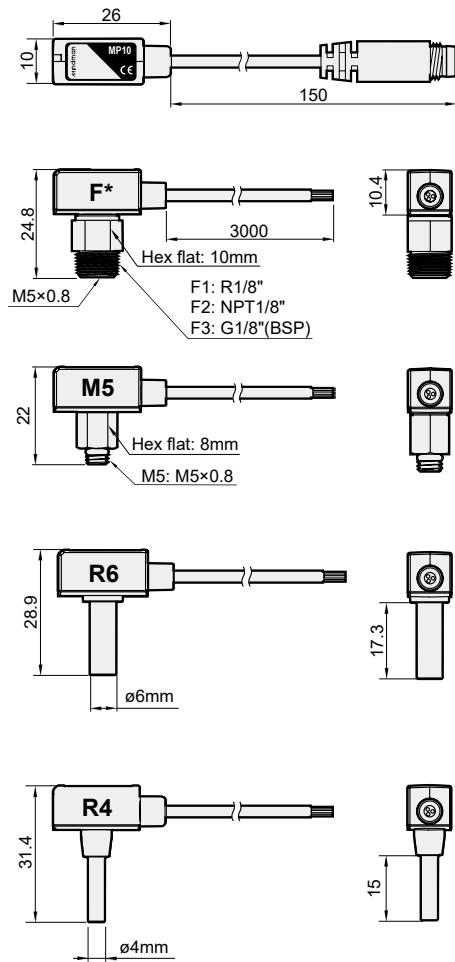

QD Pinout

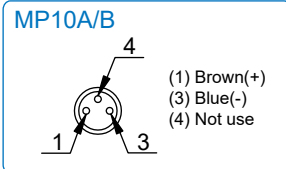
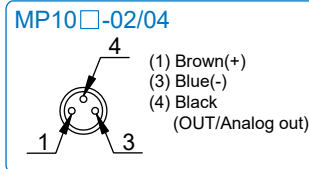

QD Pinout

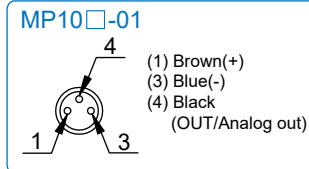

Mounting accessories (Option)

MP - D2

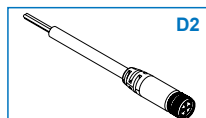
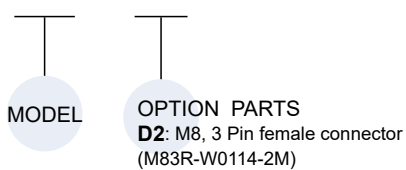

MP-D2

M8, 3 Pin female connector

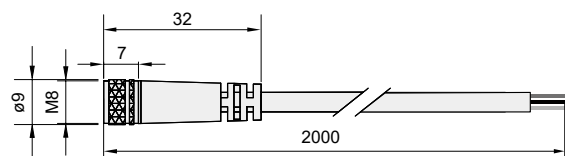



User manual



Selection table



Features

- Pressure range: Compound -100.0~100 kPa
Positive 0~1 MPa
Vacuum -101.3~0 kPa.
- 2 switch output & one analog output.
- Hysteresis adjustable.
- High accuracy and Resolution.
- Low cost.

Symbol



Specification

Model		MP30C (Compound)	MP30V (Vacuum)	MP30P (Positive)
Rated pressure range		-100.0~100.0 kPa	-101.3 ~0.0 kPa	0.0 ~ 1.0 MPa
Operating / Setting pressure range		-100.0~100.0 kPa	-101.3~10.0 kPa	-0.1 ~ 1.0 MPa
Allowable pressure		300 kPa		1.5 MPa
Fluid		Filtered air, Non-corrosive / Non-flammable gas		
Set pressure resolution	KPa	0.1		—
	MPa	—		0.001
	kgf/cm ² , bar	0.001		0.01
	psi	0.01		0.1
	InHg	0.1		—
	mmHg	1		—
	mmH ₂ O	0.1		—
Power supply voltage		12 to 24V DC±10%, Ripple (P-P) 10% or less		
Current consumption		≤ 60mA		
Switch output		NPN or PNP open collector 2 outputs Max. load current : 100mA Max. supply voltage: NPN, 30V DC; PNP, 24V DC Residual voltage : ≤1V		
Repeatability (Switch output)		± 0.2% F.S. ±1digit		
Hysteresis	Hysteresis mode	Adjustable		
	Window comparator mode	Fixed (3 digits)		
Response time		≤2.5ms (chattering-proof function: 24ms, 192ms and 768ms selections)		
Output short circuit protection		Yes		
7 segment LED display		3½ digit, 7 segment LED display (Red) (Sampling rate: 5 times/sec.)		
Indicator accuracy		±2% F.S. ±1 digit (Ambient temperature: 25 ± 3°C)		
Indicator		Green indicator : OUT1 & Red indicator : OUT2		
Analog output <i>*(Only type MP30□-01, MP30□-03)</i>		Output voltage: 1 to 5V±5% F.S. (within rated pressure range) Linearity: ±1% F.S.	Output voltage: 1 to 5V ±2.5% F.S. (within rated pressure range) Linearity: ±1% F.S.	
Environment	Enclosure	IP40		
	Ambient temp. range	Operation: 0 ~ 50°C, storage: -20 ~ 60°C (No condensation or freezing)		
	Ambient humidity range	Operation/Storage: 35 ~ 85% RH (No condensation)		
	Withstand voltage	1000V AC in 1-min. (between case and lead wire)		
	Insulation resistance	50MΩ (at 500V DC, between case and lead wire)		
	Vibration	Total amplitude 1.5mm,10Hz-55Hz-10Hz scan for 1 minute, 2 hours each direction of X, Y and Z		
	Shock	980m/s ² (100G), 3 times each in direction of X, Y and Z		

Specification

Model	MP30C (Compound)	MP30V (Vacuum)	MP30P (Positive)
Temperature characteristic	±2% F.S. of detected pressure (25°C) at temp. Range of 0~50°C		
Port size	F1: R1/8", M5×0.8; F2: NPT1/8", M5×0.8; F3: G1/8", M5×0.8		
Lead wire	ø4 Oil-resistance cable (PVC) - 26 AWG (0.15 mm ²) - 5 cores (01 / 03) , - 4 cores (02 / 04)		
Weight	Approx. 67 g (with 2 meter lead wire), Approx. 35 g (with M8 4Pin male connector)		

Output circuit wiring graph

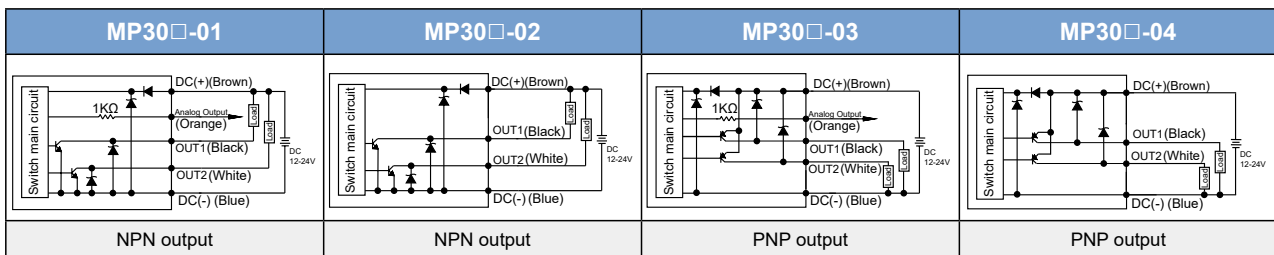

Order example

MP30C - 01 - F1 - QD

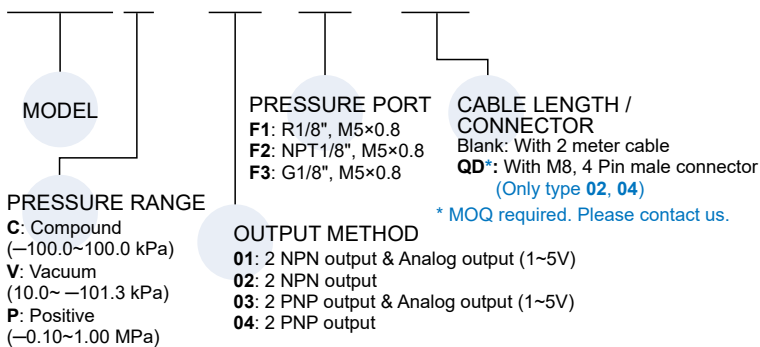

Mounting accessories (Option)

MP - D1

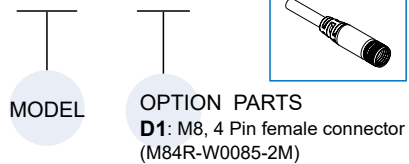

MP-D1

M8, 4 Pin female connector

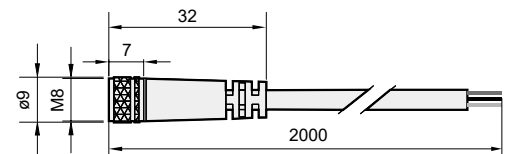

Panel instructions

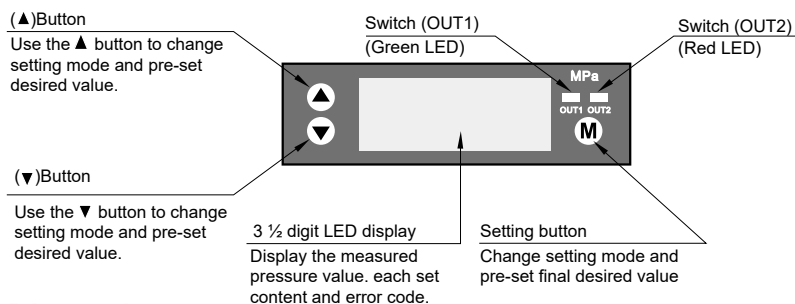

Dimensions

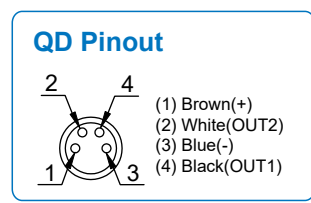
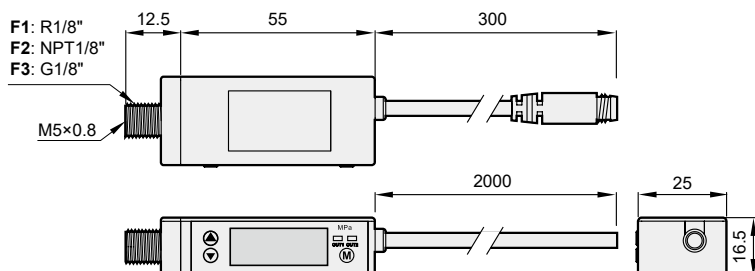



User manual



Selection table



Features

- Hysteresis adjustable.
- High accuracy and Resolution.
- Low cost.
- Pressure unit selectable: kPa, MPa, kgf/cm², bar, psi, inHg, mmHg.

Symbol

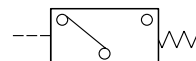

Specification

Model		MP41C (Compound)	MP41P (Positive)
Rated pressure range		- 100.0 ~ 100.0 kPa	0.0 ~ 1.0 MPa
Setting pressure range		- 101.0 ~ 101.0 kPa	- 0.1 ~ 1.0 MPa
Withstand pressure		300 kPa	1.5 MPa
Fluid		Filtered air, Non-corrosive / Non-flammable gas	
Set pressure resolution	kPa / MPa	0.1 / -	- / 0.001
	kgf/cm ² / bar	0.001	0.01
	psi	0.01	0.1
	inHg / mmHg	0.1 / 1	-
Power supply voltage		12 to 24V DC ±10%, Ripple (P-P) 10% or less	
Current consumption		≤ 40mA (With no load)	
Switch output	Output type	2 NPN or 2 PNP open collector	
	Max. load current	125mA	
	Max. supply voltage	30V DC (at NPN output), 24V DC (at PNP output)	
	Residual voltage	≤1.5V	
Response time		Chattering-proof function: 50ms, 250ms, 500ms, 1000ms, 2000ms, 3000ms selections	
Output short circuit protection		Yes	
Display	LCD display	3½ digital, 7 segment LCD display (Red / Green / Orange) (Sampling rate: 5 times/sec.)	
	Switch on indicator	Orange indicator 1 : OUT1 & Orange indicator 2 : OUT2	
	Updates time	Adjustable	
	Indicator accuracy	±2% F.S. ±1 digit (ambient temperature: 25 ± 3°C)	
Repeatability (Switch output)		± 0.2% F.S. ±1digit	
Environment	Enclosure	IP40	
	Ambient temp. range	Operation: 0 ~ 50°C, storage : - 10 ~ 60°C (No condensation or freezing)	
	Ambient humidity range	35 ~ 85% RH (No condensation)	
	Withstand voltage	1000V AC in 1-min. (between case and lead wire)	
	Insulation resistance	50M Ω min. (at 500V DC, between case and lead wire)	
	Vibration	Total amplitude 1.5mm or 10G, 10Hz-150Hz-10Hz scan for 1 minute, two hours each direction of X,Y and Z	
	Shock	100m/s ² (10G), 3 times each in direction of X,Y and Z	
Temperature characteristic		±2% F.S. of detected pressure (25°C) at temp. Range of 0~50°C	
Lead wire		ø4 Oil-resistance cable (PVC) - 26 AWG (0.15mm ²) - 4 cores	
Weight		Approx. 65 g (with 2 meter lead wire), Approx. 30g (with male connector)	

Output circuit wiring graph

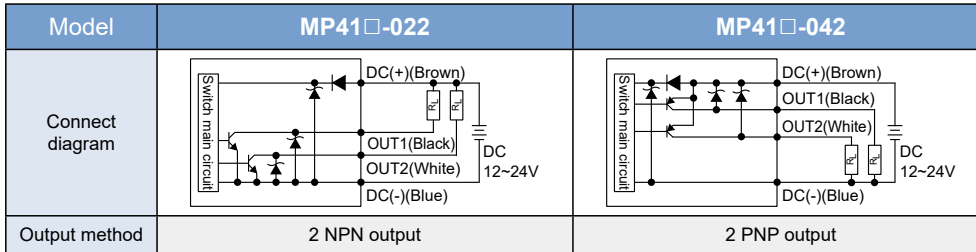

Order example

MP41P - 022 - QD - W

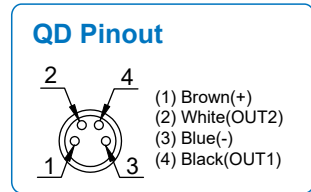
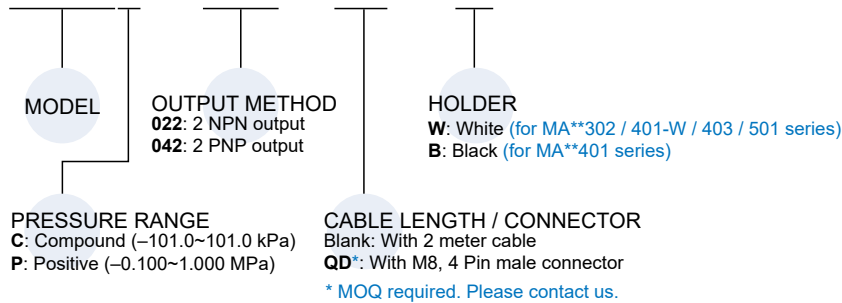

Mounting accessories (Option)

MP - D1

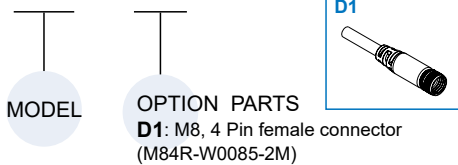

MP-D1

M8, 4 Pin female connector

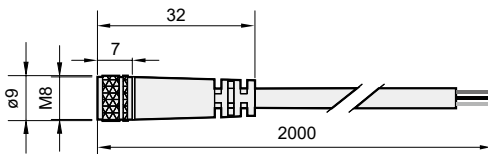

Dimensions

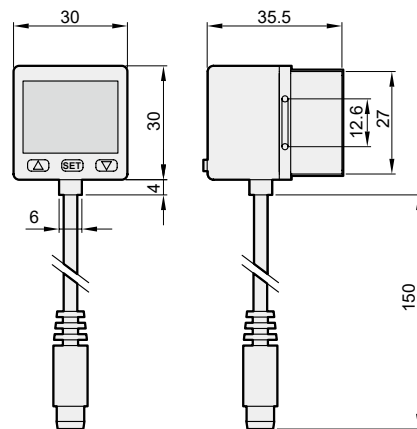

Applicable model

Series	302 / 403 / 501	401
F.R.L.Unit	MACP302 / 403 / 501	MACP401
F.R.L.Unit	MACT302 / 403 / 501	MACT401
F.R.Unit	MAFR302 / 403 / 501	MAFR401
R. Unit	MAR302 / 403 / 501	MAR401
F.R.Unit	—	MAFRF401
F.R.Unit	—	MATFR401

Panel instructions

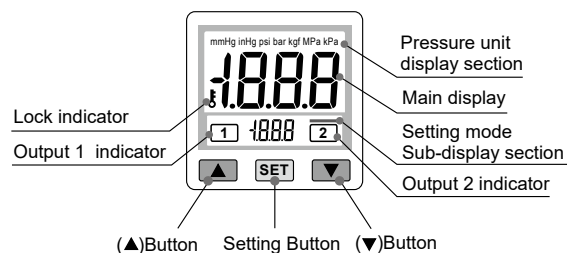

MP41 With MA**302

HIGH PRECISION DIGITAL PRESSURE SWITCH



Symbol

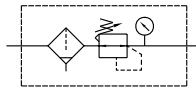

Mounting procedures

1. Fix the holder.
2. Assembly the digital pressure switch.
3. Button the n-ring.

Order example of sensor holder set

Model	Description
A-MP41-W	White. Include part ①.

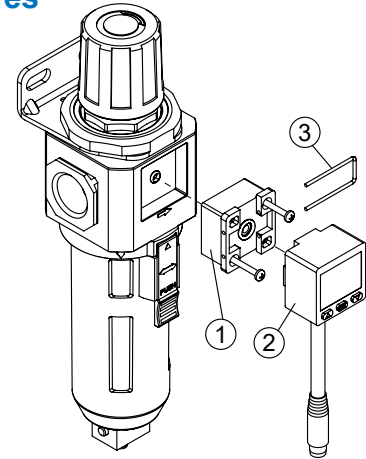

Order example

MAFR302 — 8A — □□□ — E1 — □ — G

MODEL
MACP302
MACT302
MAFR302
MAR302

PORT SIZE
8A: 1/4
10A: 3/8
15A: 1/2

PRESSURE SWITCH
E1: MP41P-022
E2: MP41P-022-QD
E5: MP41P-042
E6: MP41P-042-QD

FILTER ELEMENT
Blank: 5μm
40u: 40μm

PORT THREAD
Blank: Rc thread
G: G thread
NPT: NPT thread

(Option) ACCESSORIES

Bowl	Drain valve (*)	Flow direction
Blank: PC bowl M: Metal bowl N: Nylon bowl	Blank: Semi-auto drain D: Auto drain valve (FMRF300)	Blank: Left to right R: Right to left

* Not applicable to MAR302

MAR302

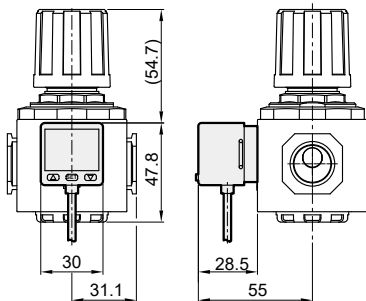

MAFR302

MAFR302-D

Auto drain valve
Operating pressure range
0.15~1 MPa

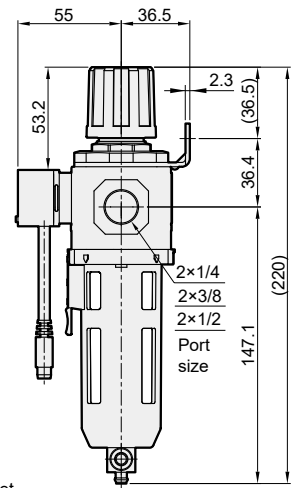
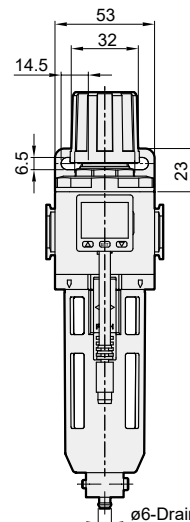
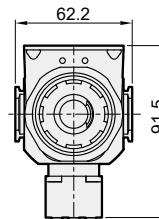
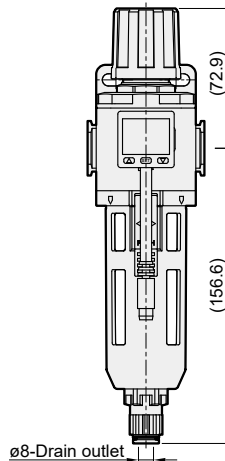

MP41 With MA**401

HIGH PRECISION DIGITAL PRESSURE SWITCH



Mounting procedures

1. Fix the holder.
2. Assembly the digital pressure switch.
3. Button the n-ring.

Order example of sensor holder set

Model	Description	
A-MP41-W	White	Include part ①
A-MP41-B	Black	①

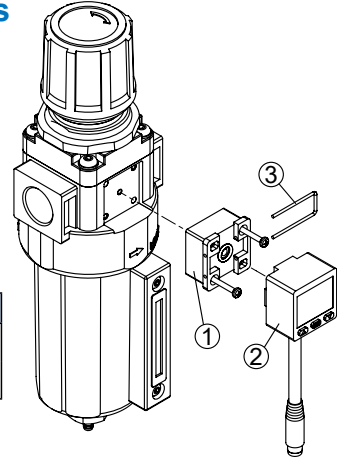

Symbol

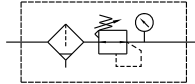

Order example

MAFR401 — 8A — □ — □□□ — E1 — □ — □ — G

MODEL
MACP401
MACT401
MAFR401
MAR401

EXTERIOR COLOR
Blank: Black & Silver
W: Gray & white

PRESSURE SWITCH
E1: MP41P-022
E2: MP41P-022-QD
E5: MP41P-042
E6: MP41P-042-QD

(*) FILTER ELEMENT
Blank: 40µm
5u: 5µm

(Option) BRACKET
Blank: Without
B2: Screw fixed (MAFR, MAR only)

PORT THREAD
Blank: Rc thread
G: G thread
NPT: NPT thread

PORT SIZE (Option) ACCESSORIES

8A: 1/4
10A: 3/8
15A: 1/2

Bowl	Drain valve (*)	Flow direction
Blank: Metal bowl	Blank: Semi-auto drain D: Auto drain valve (FMRF300)	Blank: Left to right R: Right to left

* Not applicable to MAR401

MAFR401

MAR401

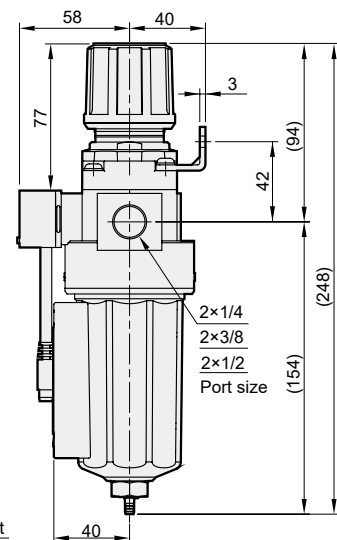
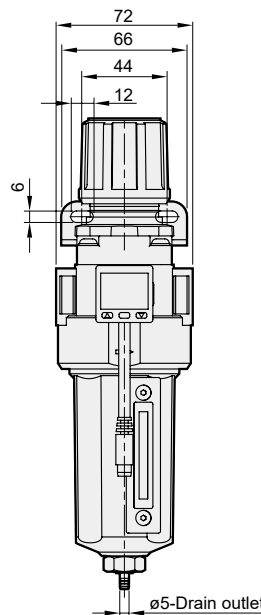
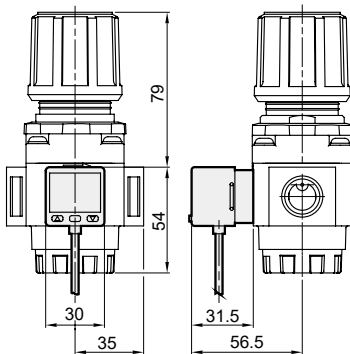

MP41 With MA**403

HIGH PRECISION DIGITAL PRESSURE SWITCH



Symbol

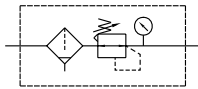

Mounting procedures

1. Fix the holder.
2. Assembly the digital pressure switch.
3. Button the n-ring.

Order example of sensor holder set

Model	Description
A-MP41-W	White. Include part ①.

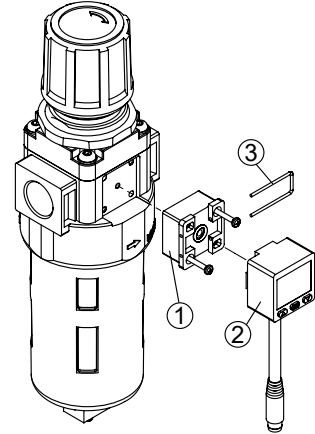

Order example

MAFR403 — 8A — □□□ — E1 — □ — □ — G

MODEL
MACP403
MACT403
MAFR403
MAR403

PORT SIZE
8A: 1/4
10A: 3/8
15A: 1/2

PRESSURE SWITCH
E1: MP41P-022
E2: MP41P-022-QD
E5: MP41P-042
E6: MP41P-042-QD

(*) FILTER ELEMENT
Blank: 40µm
5u: 5µm

(Option) BRACKET
Blank: Without
B2: Screw fixed
(MAFR, MAR only)

PORT THREAD
Blank: Rc thread
G: G thread
NPT: NPT thread

(Option) ACCESSORIES

Bowl	Drain valve (*)	Flow direction
Blank: PC bowl N: Nylon bowl	Blank: Semi-auto drain D: Auto drain valve (FMRF300)	Blank: Left to right R: Right to left

* Not applicable to MAR403

MAR403

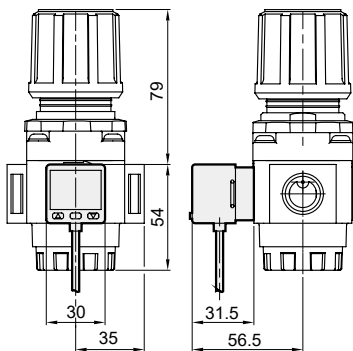

MAFR403

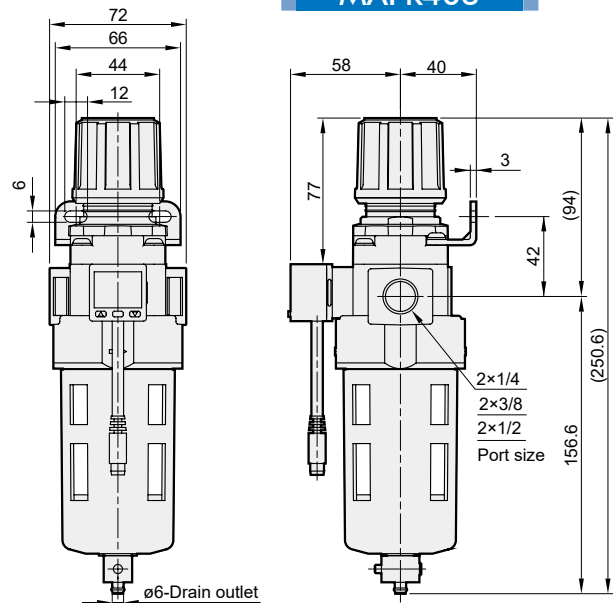

MP41 With MA**501

HIGH PRECISION DIGITAL PRESSURE SWITCH



Symbol

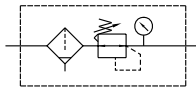

Mounting procedures

1. Fix the holder.
2. Assembly the digital pressure switch.
3. Button the n-ring.

Order example of sensor holder set

Model	Description
A-MP41-W	White. Include part ①.

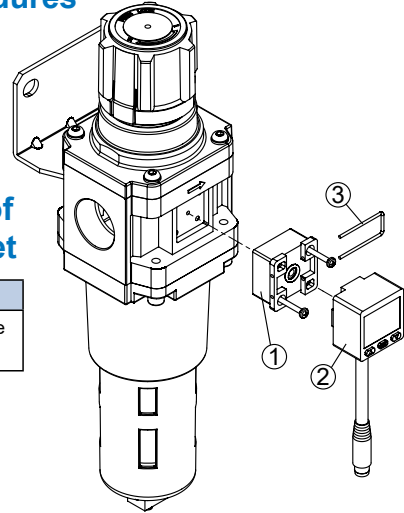

Order example

MAFR501 – 8A – □□□ – E1 – G

MODEL

MACP501
MACT501
MAFR501
MAR501

PORT SIZE

20A: 3/4
25A: 1

(Option) ACCESSORIES

Bowl	Drain valve	Flow direction
Blank: PC bowl M: Metal bowl N: Nylon bowl	Blank: Semi-auto drain D: Auto drain valve (FMRF300) * Not applicable to MAR501	Blank: Left to right R: Right to left

PRESSURE SWITCH

E1: MP41P-022
E2: MP41P-022-QD
E5: MP41P-042
E6: MP41P-042-QD

PORT THREAD

Blank: Rc thread
G: G thread
NPT: NPT thread

MAR501

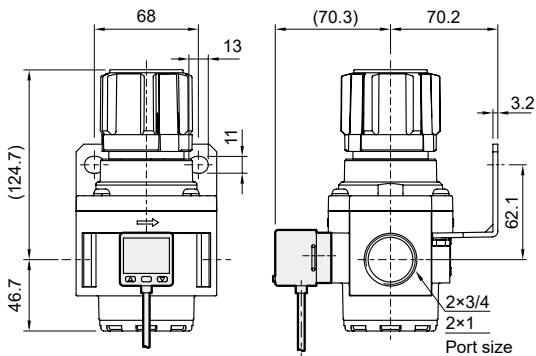

MAFR501

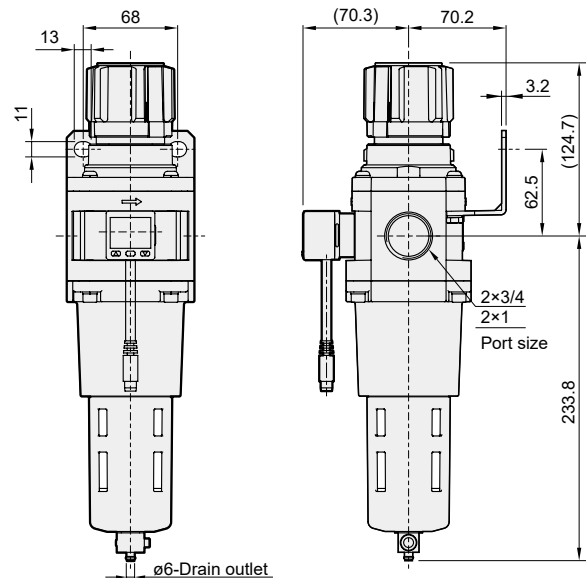

MP48E series

HIGH PERFORMANCE PRESSURE SWITCH



User manual



Selection table



Features

- Main/Sub-Display, 4 1/2 digits 7 segment LCD display.
- Multifunction sub-display.
- Switchable voltage output (1~5V or 0~10V).
- User-defined analog output range.
- Digital filter function.
- Analog output can be inverted.

Applicable industries

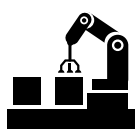

Suction

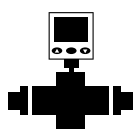

Pressure detection

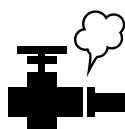

Leakage



F.R.L



Tank

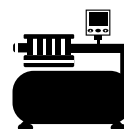

Compressor

Features highlight

Quick installation

- Save installation time.
- Easy removal.

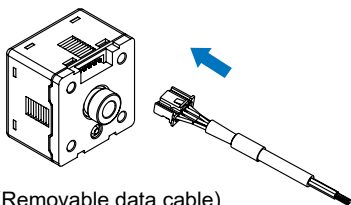

(Removable data cable)

Multifunctional sub-display

- The display can be switched between pressure unit or set points.

Pressure unit Pressure set point

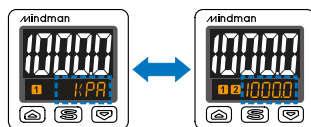

Power-save mode

- 4 level brightness adjustment leads to power savings of up to 30%. In mode 4, the sub-display shows the current pressure value.

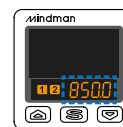

4-color display

- Choose the desired backlight to highlight different setting states.

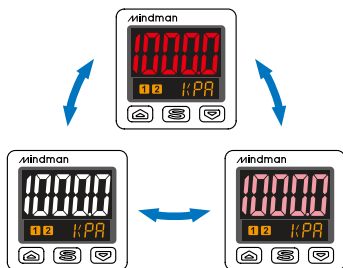

High-resolution

- Flexible switch the voltage output range.

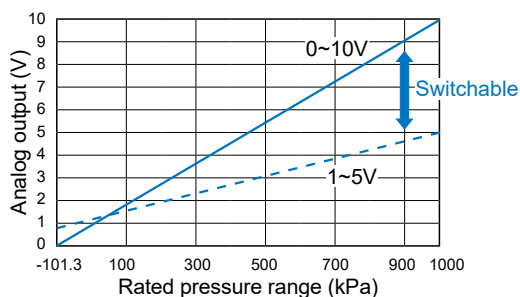
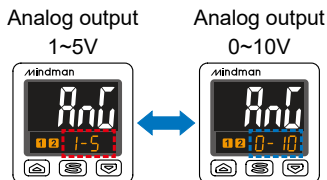

Digital filter function

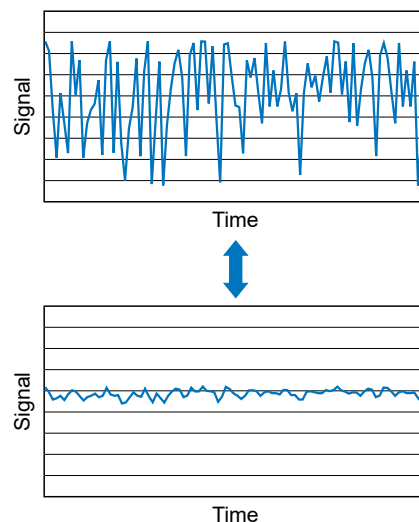

Specification

Model		MP48E	
Rated pressure range		-101.3 ~ 1000.0 kPa	
Setting pressure range		-101.3 ~ 1000.0 kPa	
Allowable pressure		1500 kPa	
Fluid		Filtered air, Non-corrosive / Non-flammable gas	
Set pressure resolution	KPa	0.1	
	MPa / kgf/cm ² / bar	0.001	
	psi	0.01	
	inHg	0.1	
	mmHg	1	
	mmAq (mmH ₂ O)	1 (*1)	
Power supply voltage		15~24V DC, Ripple (P-P) 10% or less	
Current consumption		≤ 40mA (With no load)	
Switch output		2 NPN open collector outputs Max. load current: 150mA Max. supply voltage: 30V DC Residual voltage: ≤ 1V	2 PNP open collector outputs Max. load current: 150mA Max. supply voltage: 24V DC Residual voltage: ≤ 1V
Repeatability (*2)		±0.2% S.R. (Ambient temperature: 25±3°C)	
Hysteresis		One point set/ Hysteresis/ Window comparator mode: Adjustable (Hysteresis value is adjustable within 1~8 digits for one point set mode and window comparator mode)	
Response time of digital filter (*3)		OFF, 25ms 100ms, 250ms, 500ms, 1000ms, 1500ms, 3000ms selectable	
Overcurrent protection		Yes	
Display		4 1/2 digital, 7 segment LCD display (Red / White / Pink / Orange) (Sampling rate : 0.2, 0.5, 1 sec. / time)	
Indicator accuracy (*2)		C: -100.0~100.0 kPa ± 1% S.R. V: -101.3~0.0 kPa ± 1% S.R.	P: -100.0~1000.0 kPa ± 0.5% S.R. A: -101.3~1000.0 kPa ± 0.5% S.R.
		(Ambient temperature: 25 ± 3°C)	
Switch on indicator		Orange indicator 1: OUT1 & Orange indicator 2: OUT2	
Analog output (Voltage output)		Output voltage: 0~10V ± 0.5% F.S. Linearity: ±0.5% F.S.	Output impedance: 2 kΩ
Analog output (Current output)		Output current: 4~20mA ± 0.5% F.S. Linearity: ±0.5% F.S.	Max. load impedance 250 Ω at power supply of 15V, 600Ω at power supply of 24V Min. load impedance: 50 Ω
Enclosure classification		IP40	
Ambient temp. range		Operation: 0 ~ 50°C, Storage : -10 ~ 60°C (No condensation or freezing)	
Ambient humidity range		Operation/Storage: 35 ~ 85% RH (No condensation)	
Withstand voltage		1000V AC in 1-min (between case and lead wire)	
Insulation resistance		≥ 50MΩ (at 500V DC, between case and lead wire)	
Vibration		Total amplitude 1.5mm or 10G, 10Hz-150Hz-10Hz scan for 1 minute, 2 hours each direction of X, Y and Z	
Shock		100m/s ² (10G), 3 times each in direction of X, Y and Z	
Temperature characteristic		±0.5% F.S. of detected pressure 25°C at temp. Range of 0~50°C	
Communication interface (*4)		RS485 Modbus RTU	
Port size		F1: R1/8", M5×0.8; F3: G1/8"(BSPP), M5×0.8; M5: M5×0.8 female thread	
Lead wire		ø4 PVC - 26 AWG (0.15 mm ²) - 5 cores	
Weight		Approx. 67g (with 2 meter lead wire)	

*1. If set pressure unit is mmAq, the value requires to ten multiply display value.

*2. S.R.: Set range

*3. When digital filter functions is OFF, the response time is 4~6 ms.

*4. This function only available for output specification 02R and 04R.

Output circuit wiring graph

Model	MP48E-010-□	MP48E-011-□	MP48E-02R-□
Connect diagram			
Output method	2 NPN + Analog output (1~10V)	2 NPN + Analog output (4~20 mA)	NPN output + RS485
Model	MP48E-030-□	MP48E-031-□	MP48E-04R-□
Connect diagram			
Output method	2 PNP + Analog output (1~10V)	2 PNP + Analog output (4~20 mA)	PNP output + RS485 (*)

* For RS485 Modbus wiring, please connect RS485 (B+) or (A-) before powering to avoid short circuits resulting in product damage.

Order example

MP48E — 010 — F1

MODEL

PRESSURE PORT

F1: R1/8, M5×0.8
F3: G1/8(BSP), M5×0.8

* For other specifications, please contact us.

OUTPUT METHOD

- 010: 2 NPN output + Analog output (0~10V)
- 011: 2 NPN output + Analog output (4~20mA)
- 030: 2 PNP output + Analog output (0~10V)
- 031: 2 PNP output + Analog output (4~20mA)
- 02R: 1 NPN output + RS485
- 04R: 1 PNP output + RS485

Mounting accessories (Option)

MP — A22

MODEL

OPTION PARTS

- A22: Mounting bracket
- A23: Mounting bracket
- B2: Panel adapter
- C2: Panel adapter + Front protective lid

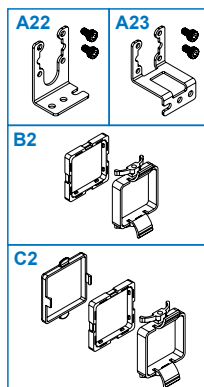

Installation precautions

- When mounting, always use the wrench on the metallic area near the pressure port. Never apply a wrench to the plastic body, it will damage the sensor.
- Over tightening may cause damages to the port thread, mounting bracket and pressure sensor. Under tightening may result loosen or leakage.
- Apply pressure and power after installation and make necessary adjustments and inspect any possible signs of leakage to ensure proper installation.

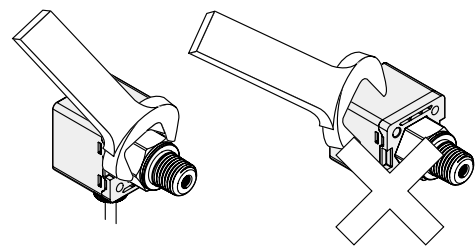

Panel instructions

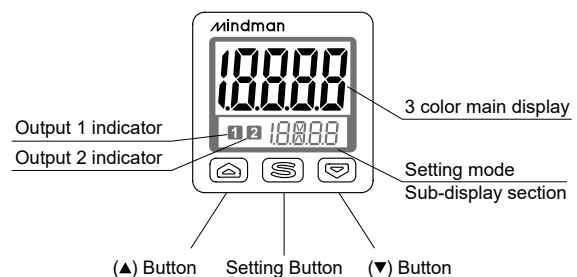

Dimensions

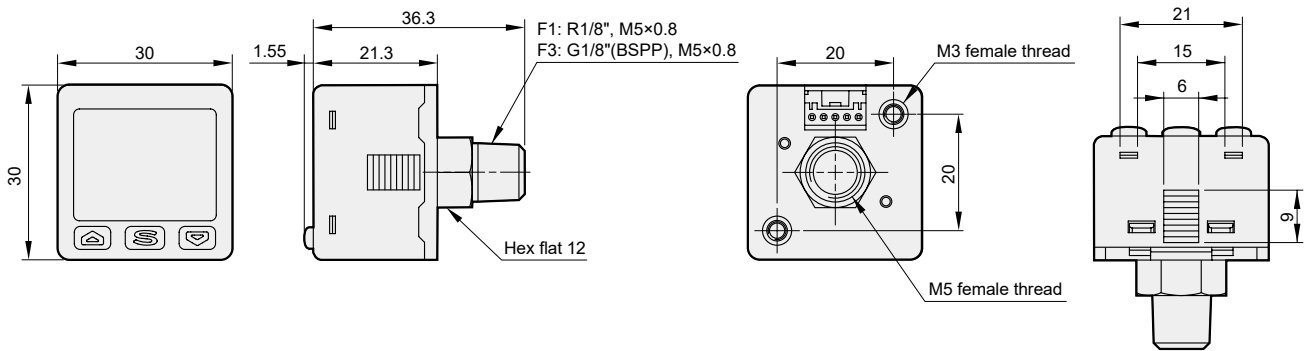

Mounting accessories

Mounting bracket

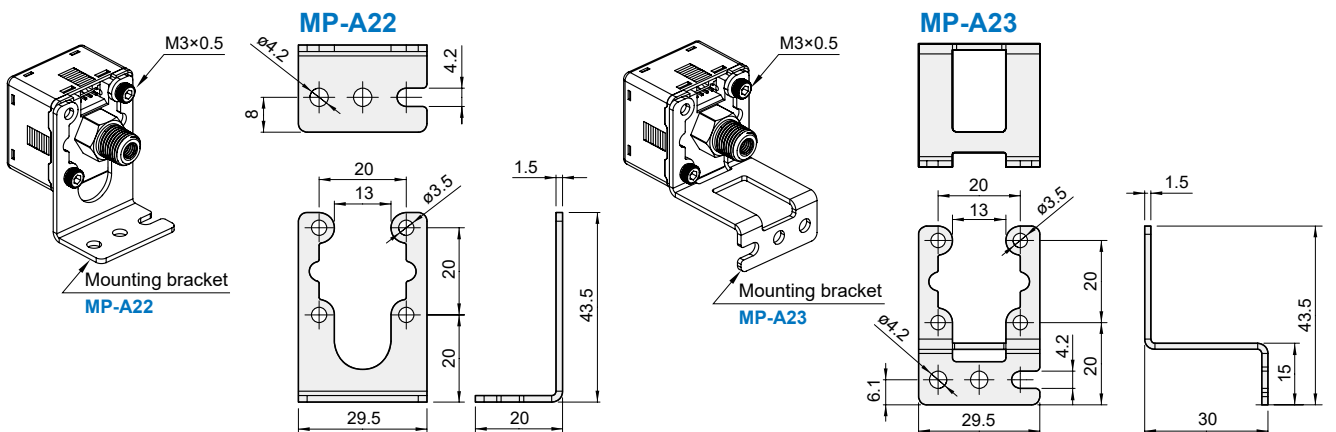

Panel type

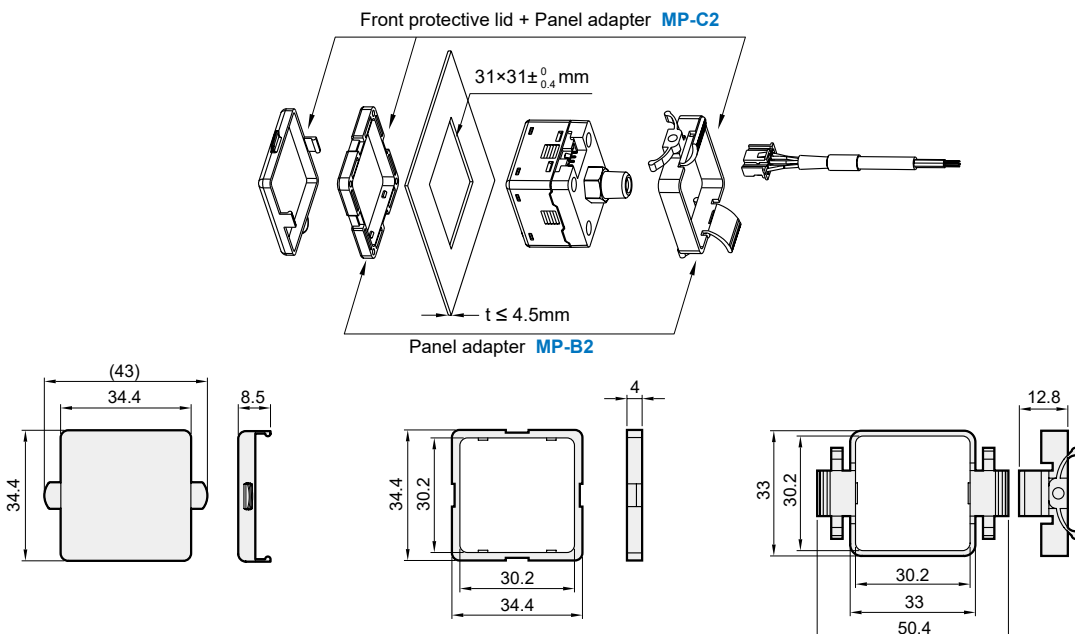

MP50 / 75 series

HIGH PRECISION DIGITAL PRESSURE SWITCH



MP50 user manual



MP75 user manual



Selection table



Features

- 2 color digital LCD display.
- Programmable pressure unit: kPa, MPa, kgf/cm², bar, psi, inHg.
- Sensor parts & fitting parts: Stainless steel 316L.
- Corrosive fluid or gas available.
- IP65 enclosure.

MP50

- Copy function.

MP75

- IOT pneumatic & hydraulic pressure sensor (multi-medium)
- Remote control / Real-time monitoring
- RS485 Modbus RTU / ASCII

Features highlight

Quick installation

- Save installation time.
- Easy removal.

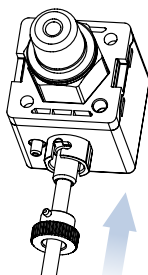

(Removable data cable)

Easy unit identification

- Unit conversion easy to read.

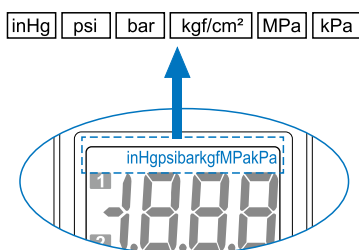

IP65 enclosure

- Protected against water and dustsplashes from all directions.



2-Color Main display

- User selectable color mode, for different conditions use.

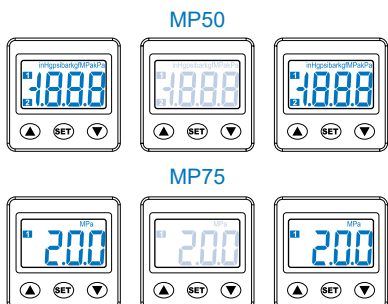

	SoL	SoR	UrL	UrR
ON	Green	Red	Green	Red
OFF	Red	Green	Green	Red

Copy setting (MP50 only)

- Reduce setting time.
- Avoid setting errors.

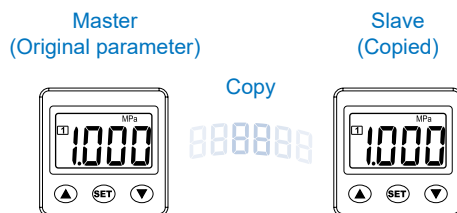

Can copy the setting value from master to slave sensor.

Applicable for Corrosive Fluid or Gas

- Sensor parts & Fitting parts are SUS316L, applicable for corrosive fluid or gas equipment.



MP50 Specification

Model		MP50P (Positive)	MP50H (High)	MP50V (Vacuum)	MP50C (Compound)
Rated pressure range		0 ~ 1.0 MPa	0.0 ~ 2.0 MPa	- 101.3 ~ 0.0 kPa	- 100.0 ~ 100.0 kPa
Setting pressure range		- 0.1 ~ 1.0 MPa	- 0.1 ~ 2.0 MPa	- 101.3 ~ 10.0 kPa	- 101.0 ~ 101.0 kPa
Allowable pressure		3 MPa		300 kPa	
Set pressure resolution	KPa	—	—	0.1	
	MPa	0.001	0.001(~1.999) / 0.01(2.00~)	—	
	kgf/cm ² / bar	0.01	0.01(~19.99) / 0.1(20.0~)	0.001	
	psi	0.1	0.1(~199.9) / 1(200~)	0.01	
	inHg	—	—	0.1	
Switch output		NPN: open collector 2 outputs Max. load current : 125mA Max. supply voltage: 30V DC Residual voltage : ≤1.5V		PNP: open collector 2 outputs Max. load current : 125mA Max. supply voltage: 24V DC Residual voltage : ≤1.5V	
Switch ON indicator		Orange indicator 1: OUT1 & Orange indicator 2: OUT2			
Hysteresis mode	One point set / Hysteresis / Window comparator	Adjustable *1			
Analog output (voltage output) *2		Output Voltage: 1 to 5V ±2.5%F.S. (within rated pressure range) Linearity: ±1% F.S. Output impedance: about 1kΩ			
Analog output (current output) *3		Output Current: 4 to 20mA ≤±2.5%F.S. (within rated pressure range); Linearity: ±1% F.S. Max. load impedance: 250Ω at power supply of 12V, 600Ω at power supply of 24V Min. load impedance: 50Ω			

*1. Hysteresis value is adjustable within 1~8 digits for one point set and window comparator mode.

*2. If analog voltage output is selected, the analog current output cannot be selected at the same time.

*3. If analog current output is selected, the analog voltage output cannot be selected at the same time.

MP75 Specification

Model		MP75P (Positive)	MP75H02 (High)	MP75C (Compound)
Rated pressure range		0 ~ 1.0 MPa	0.0 ~ 2.0 MPa	- 100.0 ~ 100.0 kPa
Setting pressure range		- 0.1 ~ 1.0 MPa	- 0.1 ~ 2.0 MPa	- 101.0 ~ 101.0 kPa
Allowable pressure		3 MPa		300 kPa
Set pressure resolution	KPa	—	—	0.1
	MPa	0.001	0.001(~1.999) / 0.01(2.00~)	—
	kgf/cm ² / bar	0.01	0.01(~19.99) / 0.1(20.0~)	0.001
	psi	0.1	0.1(~199.9) / 1(200~)	0.01
	InHg	—	—	0.1
Switch output		1 NPN or 1 PNP open collector Max. Load Current : 125 mA Max. Supply Voltage : 1 NPN 30 V DC, 1 PNP 24 V DC Residual Voltage : ≤ 1.5 V		
Switch ON indicator		Orange indicator 1: OUT		
Communication interface		RS485		

MP50 / 75 Specification

HIGH PRECISION DIGITAL PRESSURE SWITCH



Solenoid Valve

Process Valve

Pilot & Mechanical Valve

Air Treatment Unit

Pressure Switch

Compressed Air Dryer

Auxiliary Equipment

PISCO®

PLC Control System

MP50 / 75 Specification

Model	MP50 / 75	
Fluid	Fluids do not corrode stainless steel 316L	
Sealed liquid	Silicon oil	
Power supply voltage	12 ~ 24V DC ±10%, Ripple (P-P) 10% or less	
Current consumption	≤ 40mA (With no load)	
Repeatability	± 0.3% F.S. ±1 digit	
Response time	≤ 2.5ms (chattering-proof function: 25ms, 100ms, 250ms, 500ms, 1000ms and 1500ms selectable)	
Output short circuit protection	Yes	
Display	3 ½ digital, 7 segment LCD display (Red / Green / Orange) (Sampling rate : 5 times / sec.)	
Indicator accuracy	±2% F.S. ±1 digit (Ambient temperature: 25 ± 3°C)	
Environment	Enclosure classification	IP65 *1
	Ambient temp. range	Operation: 0 ~ 50°C, storage : -10 ~ 60°C (No condensation or freezing)
	Ambient humidity range	35 ~ 85% RH (No condensation)
	Withstand voltage	250V AC in 1-min. (between case and lead wire)
Environment	Insulation resistance	≥ 50MΩ (at 500V DC, between case and lead wire)
	Vibration	Total amplitude 1.5mm or 10G, 10Hz~55Hz~10Hz scan for 1 minute, 2 hours each direction of X, Y and Z
	Shock	100m/s ² (10G), 3 times each in direction of X, Y and Z
Temperature characteristic	±3% F.S. of detected pressure (25°C) at temp. range of 0 ~ 50°C	
Port size *2	F1: R1/4", M5; F2: NPT1/4", #10-32 UNF; F3: G1/4"(BSPP), M5	
Lead wire	ø4 Oil-resistance cable (PVC) - 26 AWG (0.15 mm ²) - 5 cores	
Weight (with 2 meter lead wire)	Approx. 110 g (Rear ported), Approx. 150 g (Bottom ported)	

*1. Dustproof protector must be installed to maintain IP65.

*2. G port O-ring material is NBR. If any special request, please contact us.

Output circuit wiring graph

Model	MP50□-010	MP50□-011	MP50□-02
Connect diagram			
Output method	2 NPN+Analog(Voltage) output (1~5V)	2 NPN+Analog(Current) output (4~20mA)	2 NPN+Copy function
Model	MP50□-030	MP50□-031	MP50□-04
Connect diagram			
Output method	2 PNP+Analog(Voltage) output (1~5V)	2 PNP+Analog(Current) output (4~20mA)	2 PNP+Copy function
Model	MP75□-02-□	MP75□-04-□	
Connect diagram			
Output method	NPN output + RS485	PNP output + RS485	

* Procedure to wiring RS485 products:
To prevent product damage due to short circuit, MUST do RS485 line connection before power line connection.

Installation precautions

- When mounting, always use the wrench on the metallic area near the pressure port. Never apply a wrench to the plastic body, it will damage the sensor.
- Over tightening may cause damages to the port thread, mounting bracket and pressure sensor. Under tightening may result loosen or leakage.
- Apply pressure and power after installation and make necessary adjustments and inspect any possible signs of leakage to ensure proper installation.

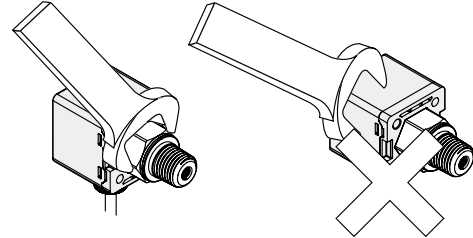

Order example

MP75C – 02 – F1 □

1 2 3 4 5

1 2 3

MODEL	PRESSURE RANGE	OUTPUT METHOD
MP50	P: Positive (– 0.1~1.0 MPa)	010: 2 NPN output + 1 Analog output (1~5V)
	H: High (– 0.1~2.0 MPa)	011: 2 NPN output + 1 Analog output (4~20mA)
	V: Vacuum (– 101.3~10.0 kPa)	02 : 2 NPN output + Copy function
	C: Compound (– 101.0~101.0 kPa)	030: 2 PNP output + 1 Analog output (1~5V)
MP75	P: Positive (– 0.1~1.0 MPa)	031: 2 PNP output + 1 Analog output (4~20mA)
	H02: High (– 0.1~2.0 MPa)	04 : 2 PNP output + Copy function
	C: Compound (– 101.0~101.0 kPa)	02: NPN output + RS485
		04: PNP output + RS485

4 5

PRESSURE PORT	PIPING DIRECTION
F1: R1/4, M5×0.8	Blank: Rear ported L: Bottom ported
F2: NPT1/4", #10-32UNF	
F3: G1/4"(BSPP), M5×0.8	

Panel instructions

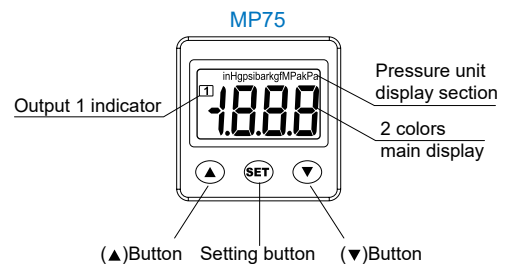
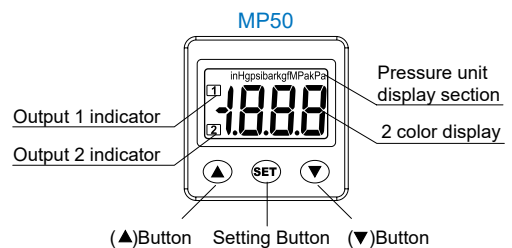

Mounting accessories (Option)

MP – A10

- MODEL OPTION PARTS
- A10: Mounting bracket
 - A11: Mounting bracket
 - B3: Panel adapter
 - C3: Panel adapter + Front protective lid
 - E1: Snubber (for Pressure Port F1 & F3)
 - E2: Snubber (for Pressure Port F2)

* MP50P & MP50H & MP75P & MP75H02 suggest to select a snubber.

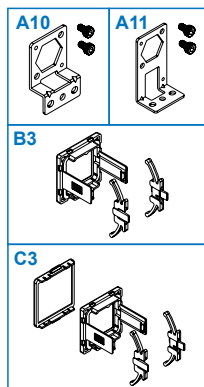

MP-E*

Removable snubber installed

- Pressure port equipped with snubber can avoid damage caused by sudden pressure surge of water or oil, improve product durability.

* When snubber is clogged with contaminants, please use a flat head screwdriver to remove the snubber, clean and reinstall.

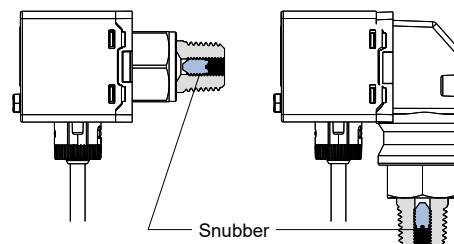

MP50 / 75 Dimensions

HIGH PRECISION DIGITAL PRESSURE SWITCH



Dimensions

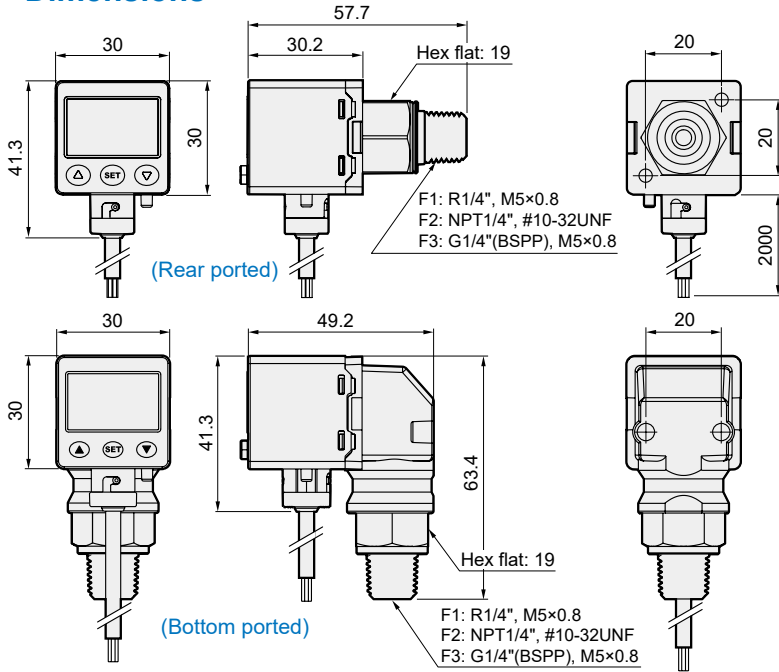

Accessory

IP65 protector

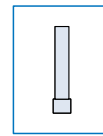
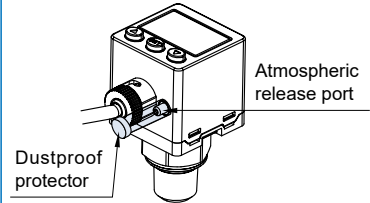

Caution

This device must be installed to maintain IP 65 (Dust and splash proof) enclosure rating.

Mounting bracket

MP-A10

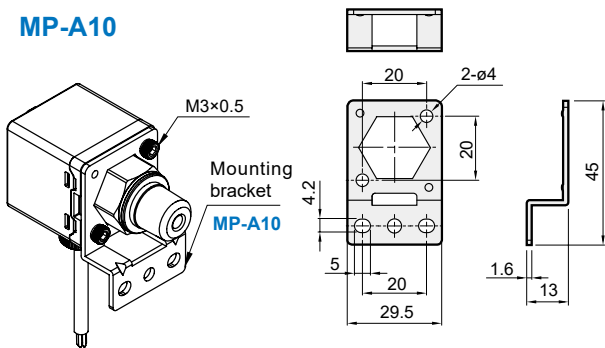

MP-A11

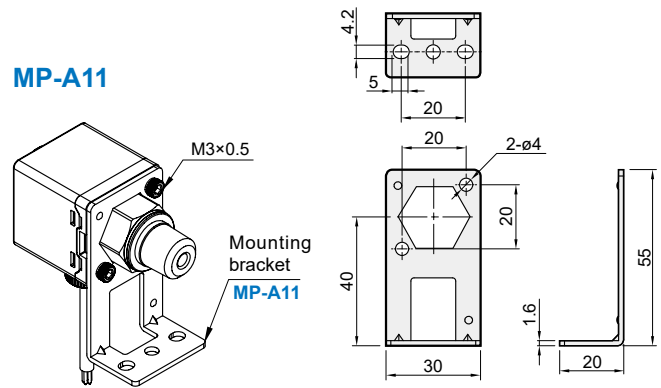

Panel type

Front protective lid + Panel adapter MP-C3

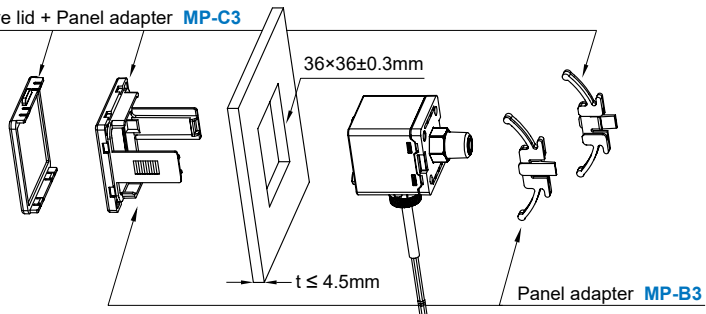

Front protective lid

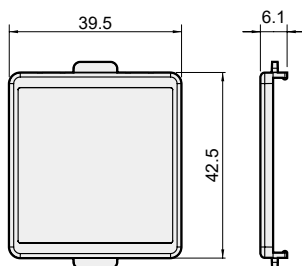

Panel adapter

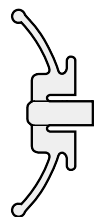
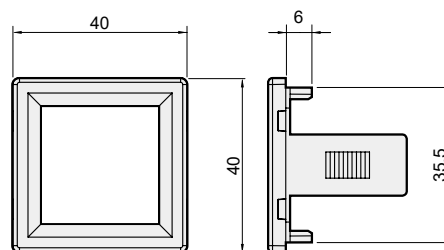



User manual



Features

- 2 output & analog output (1 ~ 5 V)
- 10 mm width with compact size
- Key-lock function
- Selectable pressure unit:
kPa, MPa, kgf / cm², bar, psi, inHg, mmHg
- Applicable for semiconductor manufacturing process, please consult us for further information.

Specification

Model		MP90P (Positive)	MP90V (Vacuum)	MP90C (Compound)
Rated pressure range		0.000 ~ 1.000 MPa	- 101.3 ~ 0.0 kPa	- 100.0 ~ 100.0 kPa
Setting pressure range		- 0.100 ~ 1.000 MPa	- 101.3 ~ 10.0 kPa	- 101.0 ~ 101.0 kPa
Allowable pressure		1.5 MPa	500 kPa	
Fluid		Filtered Air, Non-corrosive / Non-flammable gas		
Set pressure resolution	KPa	—	0.1	0.1
	MPa	0.001	—	—
	kgf/cm ² / bar	0.01	0.001	0.001
	psi	0.1	0.01	0.01
	InHg	—	0.1	0.1
	mmHg	—	1	1
Power supply voltage		12 to 24V DC ±10%, Ripple (P-P) 10% or less		
Current consumption		≤ 40mA (With no load)		
Switch output		2 NPN : open collector 2 outputs Max. Load Current : 125 mA Max. Supply Voltage : 30 V DC Residual Voltage : ≤ 1.5 V		2 PNP : open collector 2 outputs Max. Load Current : 125 mA Max. Supply Voltage : 24 V DC Residual Voltage : ≤ 1.5 V
Repeatability		± 0.2% F.S. ±1 digit		
Hysteresis	Hysteresis Mode	Adjustable		
	Window Comparator Mode	Fixed (3 digits)		
Response time		≤ 2.5ms (chattering-proof function: 25ms, 100ms, 250ms, 500ms, 1000ms and 1500ms selectable)		
Output short circuit protection		Yes		
Display		4 digit, 7 segment LED display (Red) (Sampling rate : 5 times / sec.)		
Indicator accuracy		±2% F.S. ±1 digit (Ambient temperature: 25 ± 3°C)		
Switch on indicator		Indicator Red : OUT1 & Indicator Green : OUT2		
Analog Output (Voltage Output)		Output Voltage : 1 ~ 5 V ± 2.5 % F.S. (within rated pressure range) Linearity : ± 1 % F.S. Output Impedance : about 1 kΩ		
Environment	Enclosure	IP40		
	Ambient temp. range	Operation: 0 ~ 50°C, storage : -10 ~ 60°C (No condensation or freezing)		
	Ambient humidity range	Operation / Storage: 35 ~ 85% RH (No condensation)		
	Withstand voltage	1000V AC in 1-min. (between case and lead wire)		
	Insulation resistance	≥ 50MΩ (at 500V DC, between case and lead wire)		
	Vibration	Total amplitude 1.5mm or 10G, 10Hz-55Hz-10Hz scan for 1 minute, two hours each direction of X, Y and Z		
	Shock	980 m/s ² (100G), 3 times each in direction of X, Y and Z		

(Continued)

MP90 Specifications & Order example



SLIM PRESSURE SENSOR

mindman

Specification

Model	MP90P (Positive)	MP90V (Vacuum)	MP90C (Compound)
Temperature characteristic	±2% F.S. of detected pressure (25°C) at temp. range of 0 ~ 50°C		
Port size	M5		
Lead wire	ø3.8 Oil-resistance cable (PVC) - 26 AWG (0.15 mm ²) - 5 cores		
Weight (with 2 meter lead wire)	Approx. 53 g		
Analog Output (Output range 1 to 5 V, proportional to the pressure range)			

Output circuit wiring graph

Model	MP90□-010-M5	MP90□-030-M5
Connect diagram		
Output method	2 NPN Output + Analog Output (1 ~ 5 V)	2 PNP Output + Analog Output (1 ~ 5 V)

Order example

MP90C – 010 – M5

MODEL

OUTPUT METHOD

010: 2 NPN output & Analog output (1 ~ 5 V)
030: 2 PNP output & Analog output (1 ~ 5 V)

PRESSURE PORT

PRESSURE RANGE

P: Positive (- 0.1~1.0 MPa)
V: Vacuum (- 101.3~10.0 kPa)
C: Compound (- 101.0~101.0 kPa)

Panel instructions

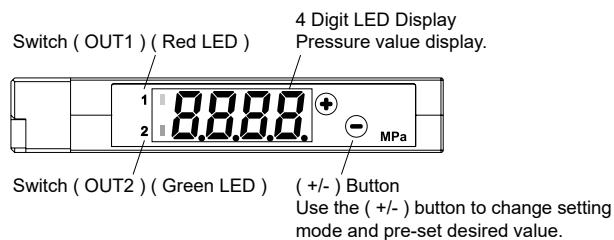

Installation precautions

- When mounting, always use the wrench on the metallic area near the pressure port. Never apply a wrench to the plastic body, it will damage the sensor.
- Do not use a sharp tool to insert the pressure inlet to avoid damaging the sensor chip.
- Do not use the product in an environment that is exposed to the splash of water or dust. Otherwise failure or malfunction may occur.

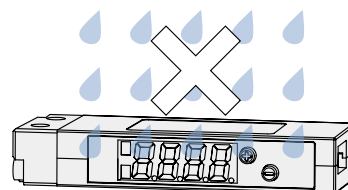
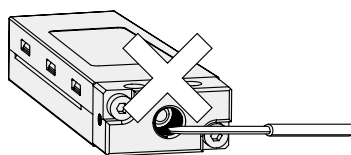
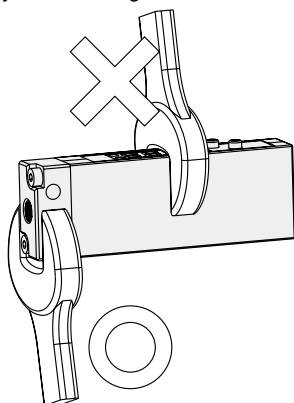

Dimensions

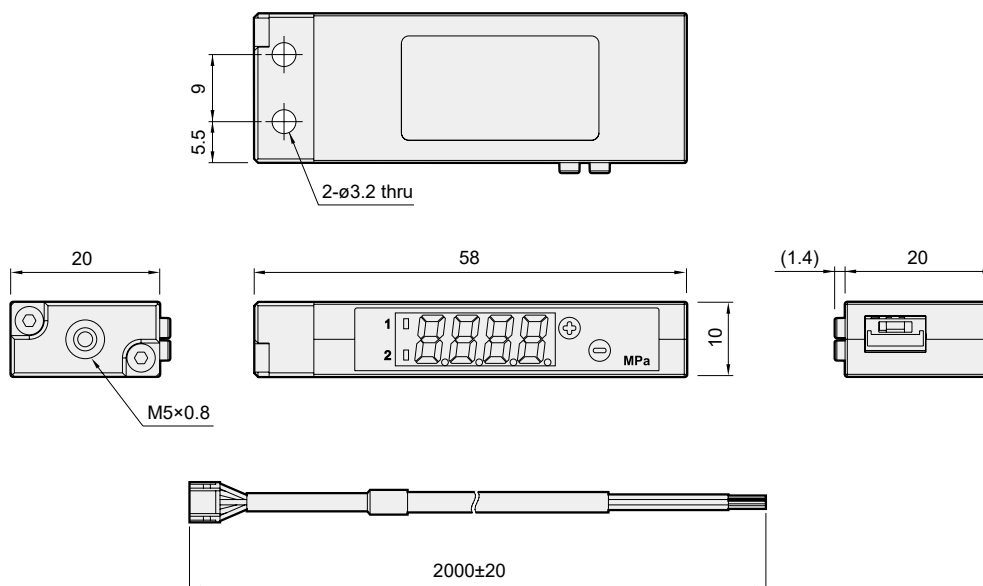



Selection table



Symbol

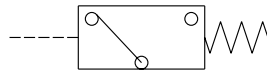

Order example

MPS - 6A - R

MODEL

Blank: by prot thread fitting
R: by O-ring fitting

Specification

Model	MPS-6A	MPS-6A-R
Fitting method	R1/8 (for port thread fitting)	O-ring: S4 (for O-ring fitting)
Ambient temperature	-5~+60°C (No freezing)	
Max. operating pressure	0.8 MPa	
Proof pressure	1 MPa	
Pressure setting range	0.1~0.7 MPa	
Operation output	Normal open ON (Red led lighting up) above value	
Sensor switch	RCE2 Reed switch / Normal open Voltage range: 5~110V DC/AC Max. Current: 100mA	
Connect diagram		
Weight	185 g	189 g

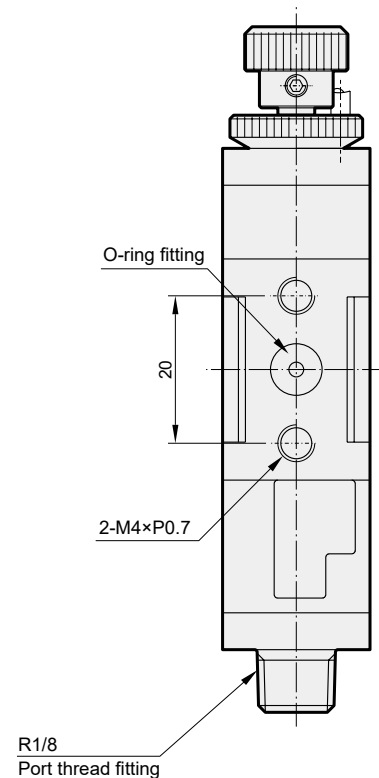
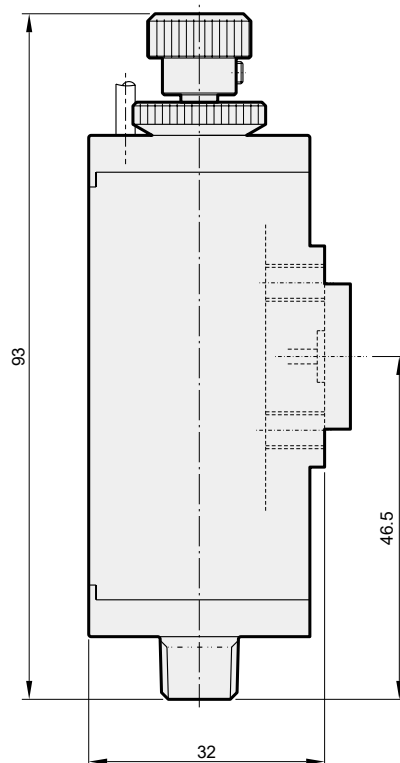
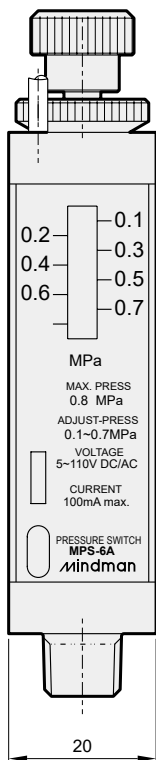

MP800 / 7800 series

DIFFERENTIAL PRESSURE SENSOR



MP800



MP7800



Features

- Digital LCD display, easy readout
- IP40 enclosure

MP800

- Pressure range: 0 ~ 1 kPa, 0 ~ 2 kPa, 0 ~ 5 kPa, -1 ~ 1 kPa, -2 ~ 2 kPa, -5 ~ 5 kPa
- Analog output: 1 ~ 5 V or 4 ~ 20 mA

MP7800

- Pressure range: -10 ~ 10 kPa, -1 ~ 1 kPa, -2 ~ 2 kPa, -5 ~ 5 kPa
- Remote control / Real-time monitoring
- RS485 Modbus RTU

Features highlight

Quick installation

- Save installation time
- Easy removal

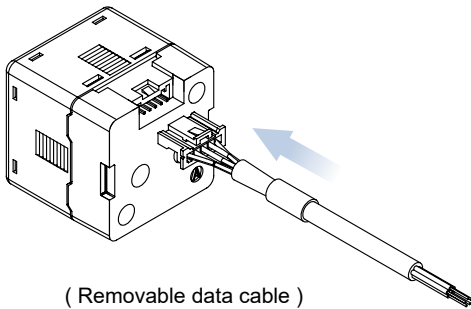

(Removable data cable)

Key-lock function

- Key-lock icon is shown on the display when the function is enabled.

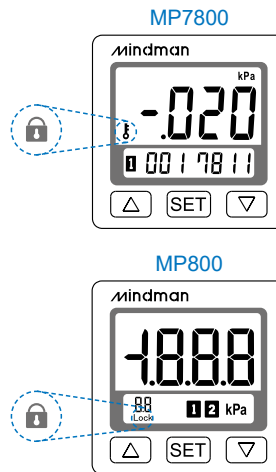

Save installation space

Actual dimension after installation

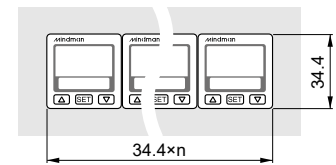

Air flow detection

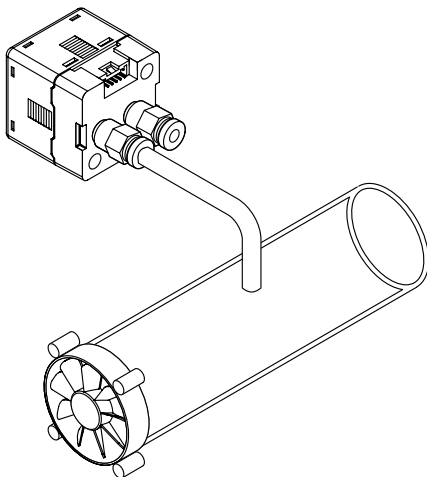

Filter air monitoring

- To monitor the clogging of filter by detecting the differential pressure.

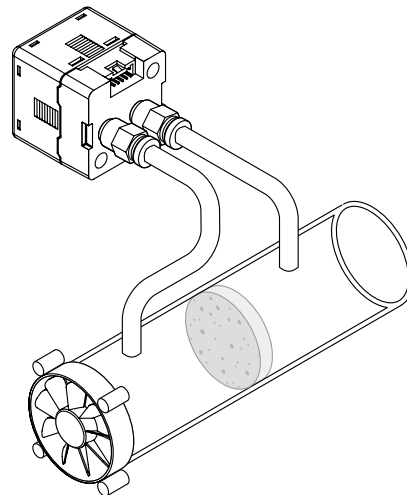

MP800 / 7800 Specification



DIFFERENTIAL PRESSURE SENSOR

mindman

MP800 Specification

Model	MP801	MP811	MP802	MP812	MP805	MP815
Rated pressure range	0 ~ 1000 Pa	-1000 ~ 1000 Pa	0.00 ~ 2.00 kPa	-2.00 ~ 2.00 kPa	0.0 ~ 5.00 kPa	-5.00 ~ 5.00 kPa
Set Pressure Range	-100 ~ 1000 Pa	-1000 ~ 1000 Pa	-0.20 ~ 2.00 kPa	-2.00 ~ 2.00 kPa	-0.50 ~ 5.00 kPa	-5.00 ~ 5.00 kPa
Withstand pressure	3 kPa		6 kPa		15 kPa	
Set pressure Resolution	Pa	1		-		
	kPa	-		0.01		
Switch output	2 NPN : open collector 2 outputs Max. Load Current : 125 mA Max. Supply Voltage : 30 V DC Residual Voltage : ≤ 1.5 V			2 PNP : open collector 2 outputs Max. Load Current : 125 mA Max. Supply Voltage : 24 V DC Residual Voltage : ≤ 1.5 V		
Display	3 ½ digital, 7 segment LCD display (White) (Sampling rate : 5 times / sec.)					
Switch on indicator	White Indicator 1 : OUT1 & White Indicator 2 : OUT2					
Analog Output (Voltage Output) *1	Output Voltage : 1 ~ 5 V ± 2.5 % F.S. (within rated pressure range) Linearity : ± 1 % F.S. Output Impedance : about 1 kΩ					
Analog output (Current Output) *2	Output Current : 4 ~ 20 mA ± 2.5 % F.S. (within rated pressure range) Linearity : ± 1 % F.S. Max. Load Impedance : 250 Ω at power supply of 12 V, 600 Ω at power supply of 24 V Min. Load Impedance : 50 Ω					

*1. If analog voltage output is selected, the analog current output cannot be selected at the same time.

*2. If analog current output is selected, the analog voltage output cannot be selected at the same time.

MP7800 Specification

Model	MP7810	MP7811	MP7812	MP7815
Rated pressure range	-10.00 ~ 10.00 kPa	-1.000 ~ 1.000 kPa	-2.00 ~ 2.00 kPa	-5.00 ~ 5.00 kPa
Set Pressure Range	-10.00 ~ 10.00 kPa	-1.000 ~ 1.000 kPa	-2.00 ~ 2.00 kPa	-5.00 ~ 5.00 kPa
Withstand pressure	30 kPa	3 kPa	6 kPa	15 kPa
Set pressure Resolution	kPa	0.01		0.01
	mmAq *1	1		1
Switch output	1 NPN : open collector 1 output Max. load current : 125 mA Max. supply voltage : 30 V DC Residual voltage : ≤ 1.5 V		1 PNP : open collector 1 output Max. load current : 125 mA Max. supply voltage : 24 V DC Residual voltage : ≤ 1.5 V	
Display	4 digital, 7 segment LCD display (White) (Sampling rate : 0.1 ~ 3 times / sec.)			
Switch on indicator	White Indicator 1 : OUT1			
Communication interface	RS485			

*1. When the unit is mmAq, the pressure unit is not displayed.

MP800 / 7800 Specification

Model		MP800 / 7800
Fluid		Filtered air, Non-corrosive / Non-flammable gas
Power supply voltage		12 ~ 24 V DC \pm 10 %, Ripple (P-P) \leq 10 %
Current consumption		\leq 40 mA (with no load)
Repeatability		\pm 0.5 % F.S. \pm 1 digit
Hysteresis	Hysteresis mode	Adjustable
	Window comparator mode	
Response Time		\leq 2.0 ms (Chattering-proof function : 32 ms, 128 ms, 1024 ms selectable)
Output short circuit protection		Yes
Indicator accuracy		\pm 2 % F.S. \pm 1 digit (Ambient temperature : 25 \pm 3 $^{\circ}$ C)
Environment	Enclosure	IP40
	Ambient temp. Range	Operation : 0 ~ 50 $^{\circ}$ C, Storage : -10 ~ 60 $^{\circ}$ C (No condensation or freezing)
	Ambient humidity range	Operation / Storage: 35 ~ 85 % RH (No condensation)
	Withstand voltage	1000 V AC in 1-min (between case and lead wire)
	Insulation resistance	\geq 50 M Ω (at 500 V DC, between case and lead wire)
	Vibration	Total amplitude 1.5 mm or 10 G, 10 Hz ~ 150 Hz ~ 10 Hz scan for 1 minute, 2 hours each direction of X, Y and Z
	Shock	100 m/s ² (10 G), 3 times each in direction of X, Y and Z
Temperature characteristic		\pm 3 % F.S. of detected pressure (25 $^{\circ}$ C) at temp. (Range of 0 ~ 50 $^{\circ}$ C)
Port size		M5 : M5 female thread
Lead wire		ϕ 4 Oil-resistance cable (PVC) - 26 AWG (0.15 mm ²) - 5 cores
Weight		Approx. 75 g (with 2 meter lead wire)

Output circuit wiring graph

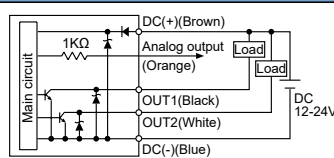
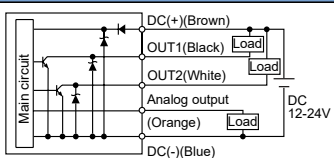
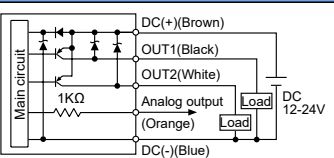
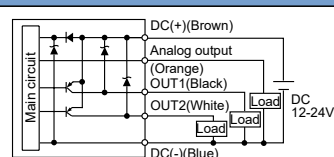
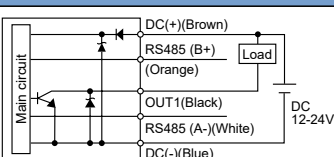
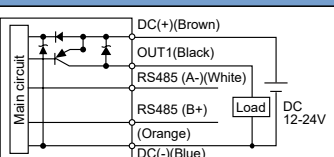
Model	MP8□-010-M5	MP8□-011-M5	MP8□-030-M5
Connect diagram			
Output method	2 NPN + Analog Output (1 ~ 5 V)	2 NPN + Analog Output (4 ~ 20 mA)	2 PNP + Analog Output (1 ~ 5 V)
Model	MP8□-031-M5	MP78□-02-M5	MP78□-04-M5
Connect diagram			
Output method	2 PNP + Analog Output (4 ~ 20 mA)	1 NPN + RS485	1 PNP + RS485

* Procedure to wiring RS485 products : To prevent product damage due to short circuit , MUST do RS485 line connection BEFORE power line connection.

Order example

MP7810 — 02 — M5

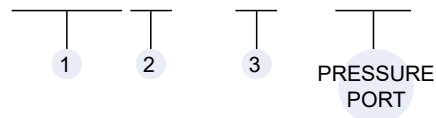

MODEL	PRESSURE RANGE	OUTPUT METHOD
MP8	01 : -100 ~ 1000 Pa	010 : 2 NPN output + 1 Analog output (1~5V) 011 : 2 NPN output + 1 Analog output (4~20mA) 030 : 2 PNP output + 1 Analog output (1~5V) 031 : 2 PNP output + 1 Analog output (4~20mA)
	02 : -0.20 ~ 2.00 kPa	
	05 : -0.50 ~ 5.00 kPa	
	11 : -1000 ~ 1000 Pa	
	12 : -2.00 ~ 2.00 kPa	
MP78	10 : -10.00 ~ 10.00 kPa	02 : 1 NPN output + RS485 04 : 1 PNP output + RS485
	11 : -1.000 ~ 1.000 kPa	
	12 : -2.000 ~ 2.000 kPa	
	15 : -5.000 ~ 5.000 kPa	

Panel instructions

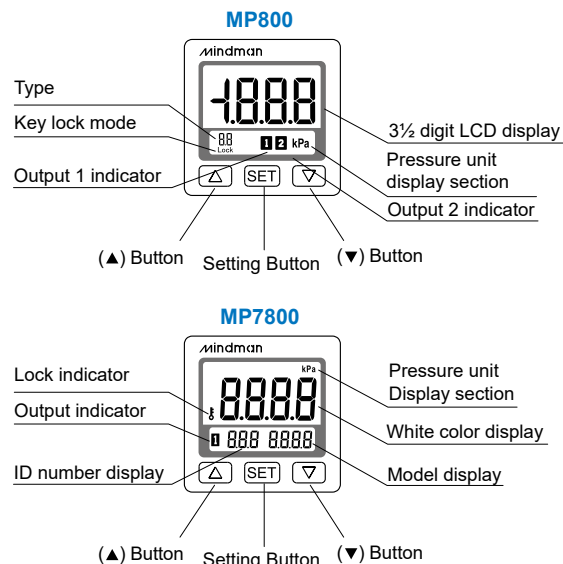

Mounting accessories (Option)

MP — A20

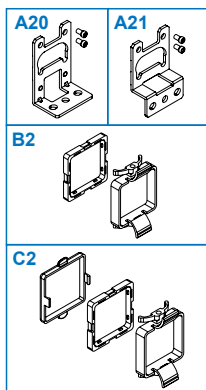
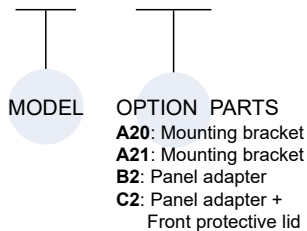

Installation precautions

- Do not use the wrench on the plastic body while connecting the sensor connector or pressure port.
- Over tightening may cause damage to the port thread, mounting bracket and pressure sensor. Under tightening may result loosen or leakage.
- Apply air pressure and power after installation, make necessary adjustments and inspect any possible signs of leakage to ensure proper installation.
- Do not insert metal or sharp objects into the pressure port.

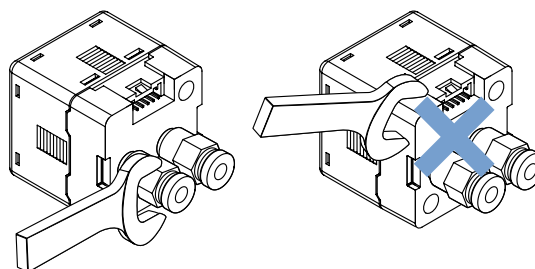

MP800 / 7800 Dimensions

DIFFERENTIAL PRESSURE SENSOR



Dimensions

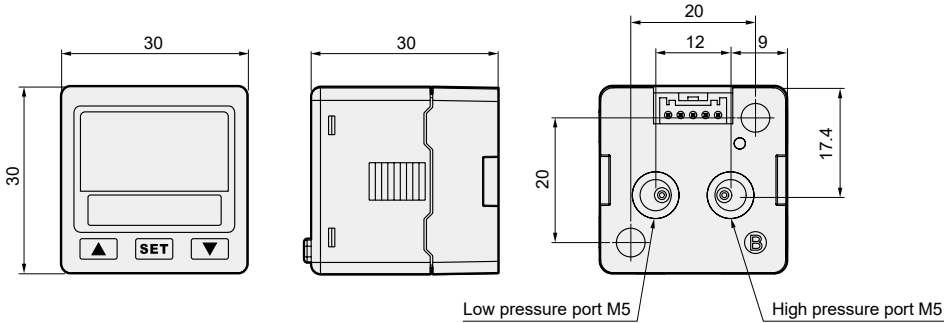

Panel opening for multiple pressure controller.

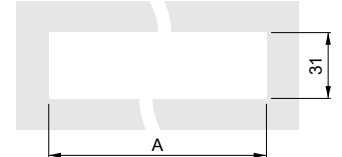

Calculation factor (A) = $(34.4 \times n) - 3.4$
n = number of controller

Mounting accessories

Mounting bracket

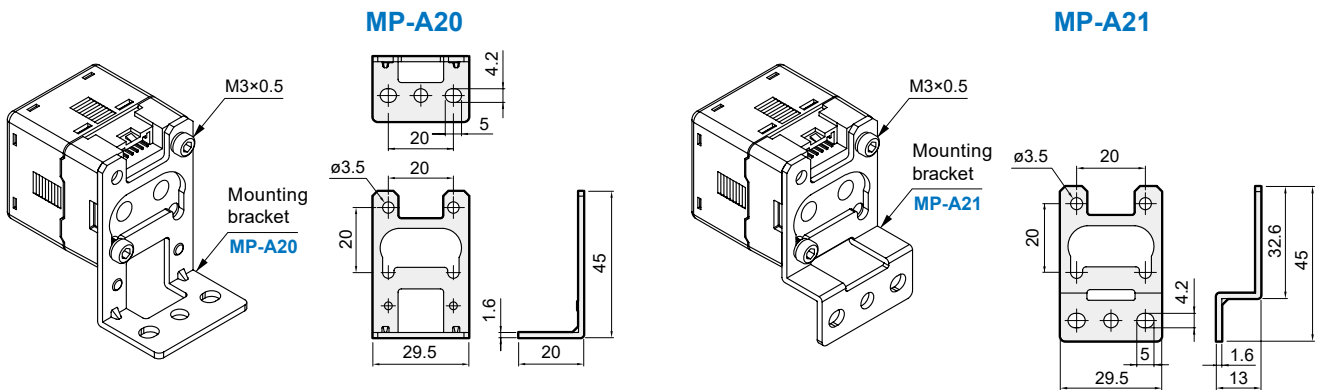

Panel type

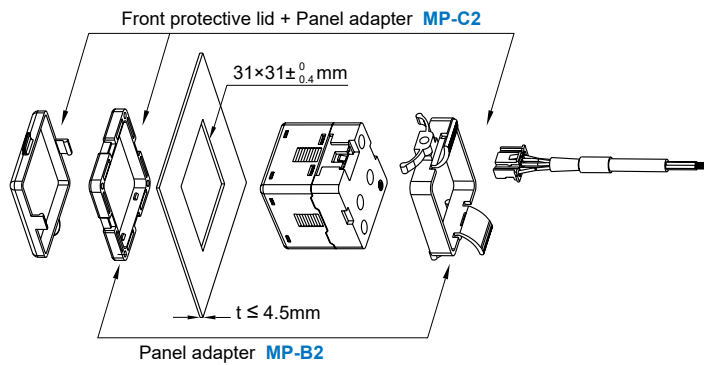

Front protective lid

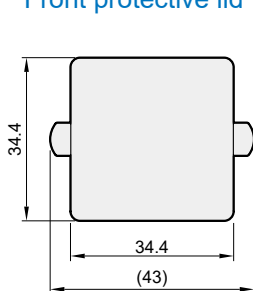

Panel adapter

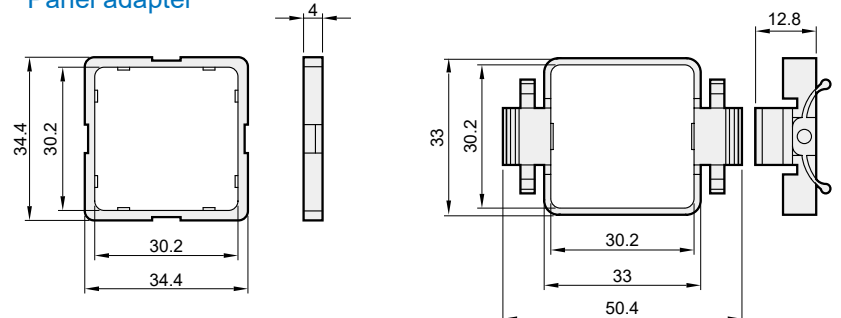



User manual



Features

- Digital LCD display
- IP65 enclosure
- Pressure range : 0 ~ 1000 kPa
- RS485 Modbus RTU
- High-resolution (10x)
- Selectable NPN or PNP open collector

Features

Quick installation

- Save Installation Time.
- Easy Removal.

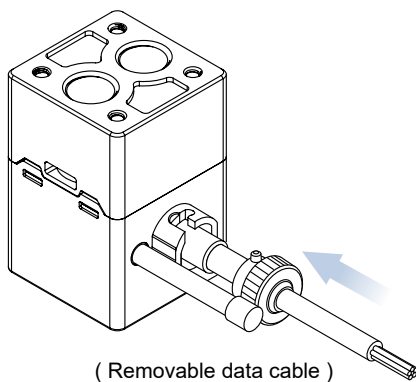

High resolution mode

- High resolution mode is settable in differential pressure range: -199.9 kPa ~ 199.9 kPa.
- Under high resolution mode, the detection are 10 times accuracy that able to measure differential pressure.

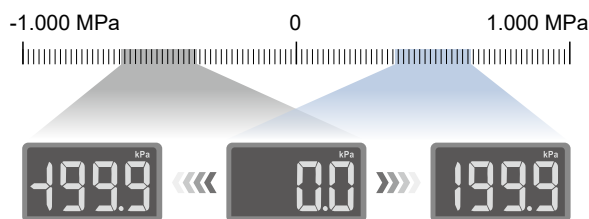

Filter air monitoring

- To monitor the clogging of filter by detecting the differential pressure.

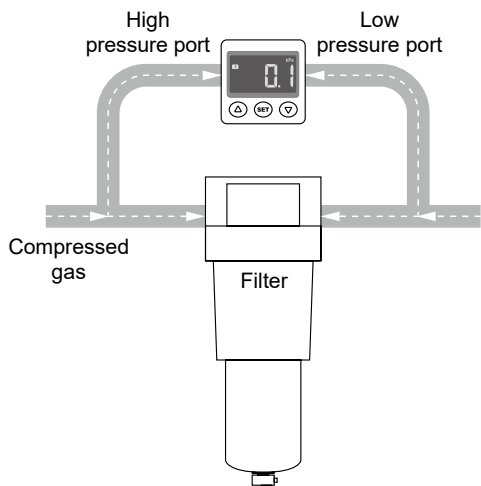

Leakage test

- To detect the differential pressure decay by sensing the change of line pressure.

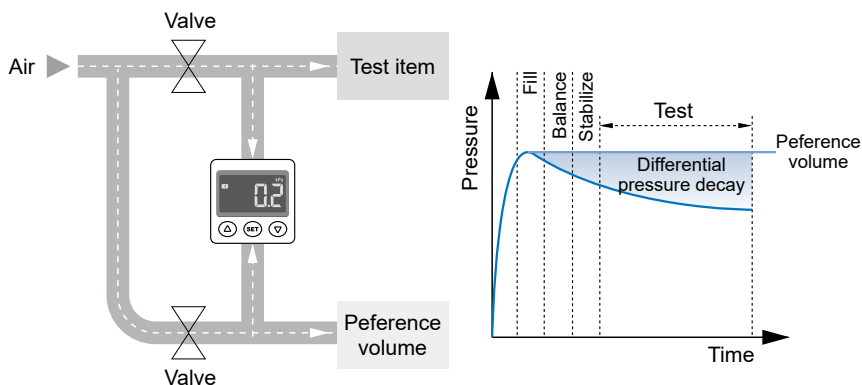

Specification

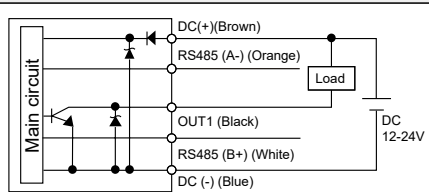
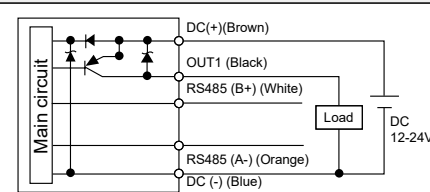
Model		MPDS-P-02	MPDS-P-04
Rated pressure range		-1000 ~ 1000 kPa	
Operating pressure range		0 ~ 1000 kPa	
Withstand pressure		1200 kPa	
Fluid		Filtered air, Non-corrosive / Non-flammable gas	
Set pressure Resolution	Standard mode 1 kpa	1 kPa	
	High resolution mode *1	0.1 kPa	
Power supply voltage		12 ~ 24 V DC \pm 10 %, Ripple (P-P) \leq 10 %	
Current consumption		\leq 20 mA	
Switch output		1 NPN open collector *2 Max. Load Current: 200 mA Max. Supply Voltage: 30 V DC Residual Voltage: \leq 1.5 V	1 PNP open collector *2 Max. Load Current: 200 mA Max. Supply Voltage: 24 V DC Residual Voltage: \leq 1.5 V
Repeatability (switch output)		\pm 0.2 % F.S. \pm 1 digit	
Hysteresis	Hysteresis mode	1 ~ 15 digits	
	Window comparator mode		
Output short circuit protection		Yes	
7 Segment lcd display		3 ½ digital, 7 segment LCD display (White) (Sampling rate: 5 times / sec.)	
Indicator accuracy	Standard mode	\pm 0.3 % F.S. \pm 1 digit (Ambient temperature: 25 \pm 3 °C)	
	High resolution mode	\pm 0.1 % F.S. \pm 1 digit (Ambient temperature: 25 \pm 3 °C)	
Switch on indicator		White indicator 1: OUT	
Environment	Enclosure	IP65 *3	
	Ambient temp. Range	Operation : 0 ~ 50 °C, Storage : -10 ~ 60 °C (No condensation or freezing)	
	Ambient humidity range	35 ~ 85 % RH (No condensation)	
	Withstand voltage	1000 V AC in 1-min (between case and lead wire)	
	Insulation resistance	\geq 50 M Ω (at 500 V DC, between case and lead wire)	
	Vibration	Total amplitude 1.5 mm, 10 Hz ~ 150 Hz ~ 10 Hz scan for 1 minute, 2 hours each direction of X, Y and Z	
	Shock	100 m/s ² (10 G), 3 times each in direction of X, Y and Z	
Temperature characteristic	Standard mode	\pm 0.5 % F.S. of detected pressure (25 °C) at temp. Range of 0 ~ 50 °C	
	High resolution mode	\pm 5 % F.S. of detected pressure (25 °C) at temp. Range of 0 ~ 50 °C	
Communication interface		RS485 RTU	
Port size		M5 : M5 female thread	
Lead wire		ϕ 4 Oil-resistance cable (PVC) - 26 AWG (0.15 mm ²) - 5 cores	
Weight (with 2 meter lead wire)		Approx. 104 g	
Output circuit wiring graph *4	Connect diagram		
	Output method	NPN + RS485	PNP + RS485

*1. High resolution mode is settable in differential pressure range : -199.9 kPa ~ 199.9 kPa

*2. Selectable NPN or PNP open collector circuits in setting.

*3. Dustproof protector must be installed to maintain IP65.

*4. Procedure to wiring RS485 products : To prevent product damage due to short circuit , MUST do RS485 line connector BEFORE power line connection.

Order example

MPDS — P — 02 — M5

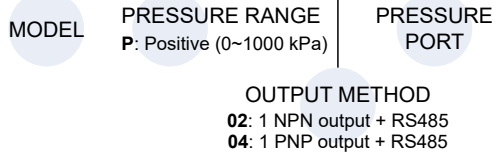

Panel instructions

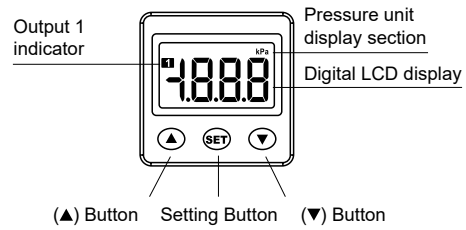

Mounting accessories (Option)

MP — A18

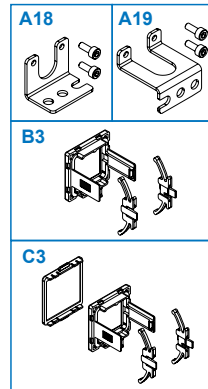
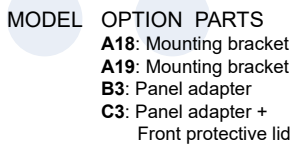

Installation precautions

- While connecting a joint to the pressure port, be sure that tightening torque must NOT exceed 1.0 N•m.

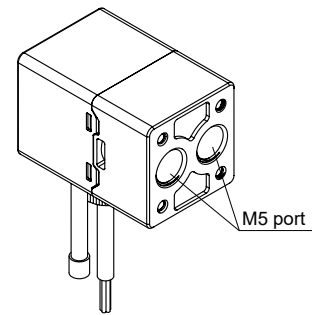

Dimensions

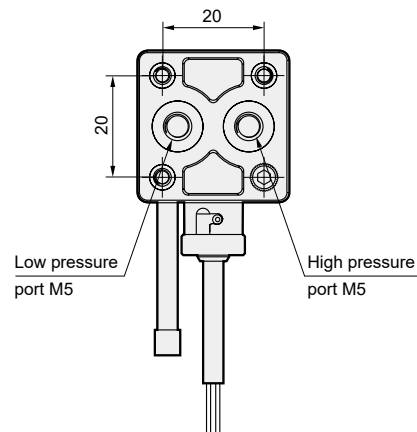
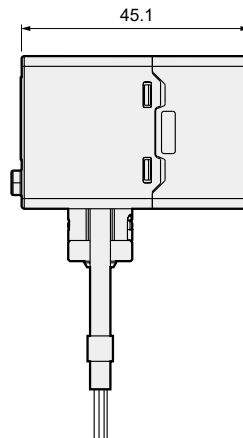
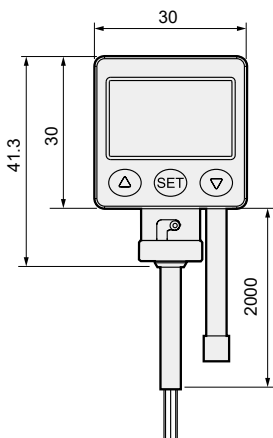

Mounting accessories

Mounting bracket

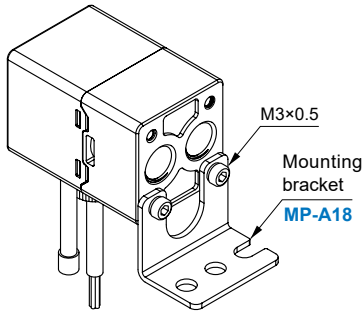

MP-A18

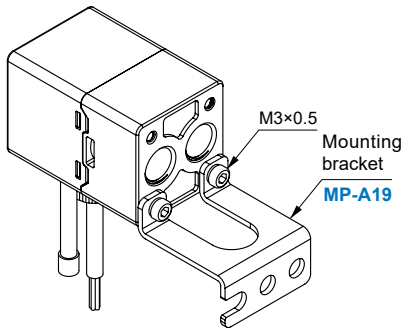
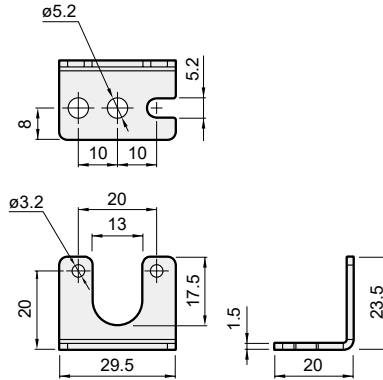

MP-A19

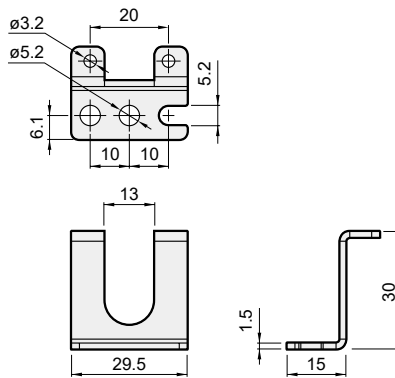

Dustproof

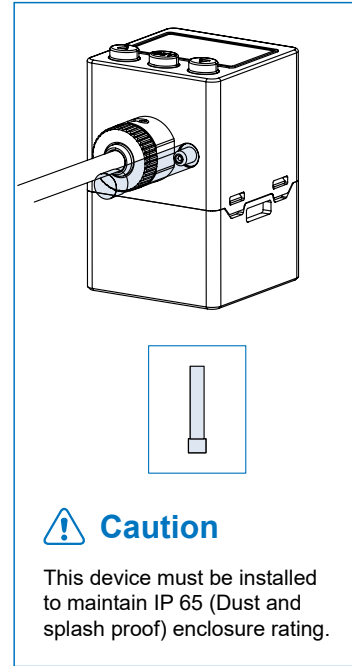

Panel type

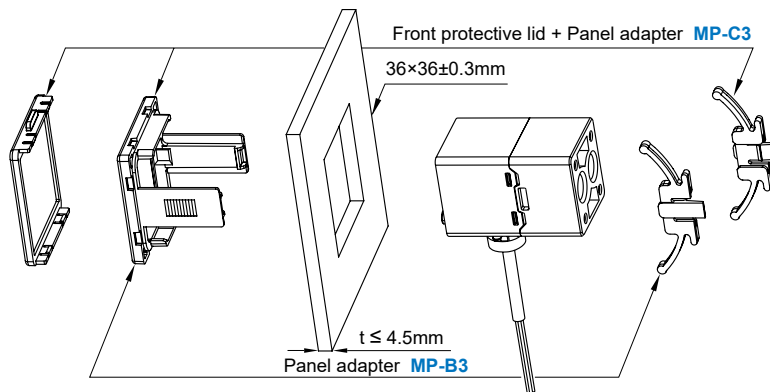

Front protective lid

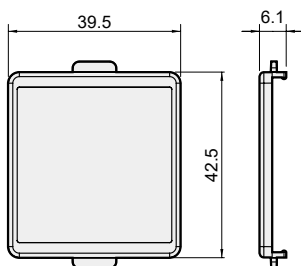

Panel adapter

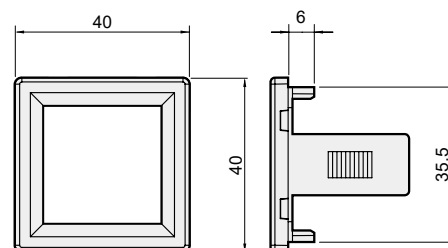



User manual



Video intro



Features

- Digital LCD display, easy readout
- IP65 enclosure
- Detection distance : 0.01 ~ 0.10 mm
- Repeatability : $\pm 5 \mu\text{m}$

Detection Circuit

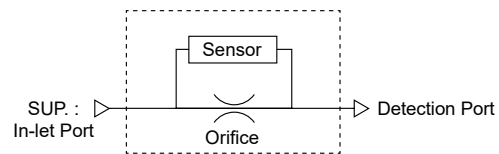

Features

Easy to check workpiece located on the right place

- Intuitive recognize in graphic interface, easy to check the gap between workpiece and platform.

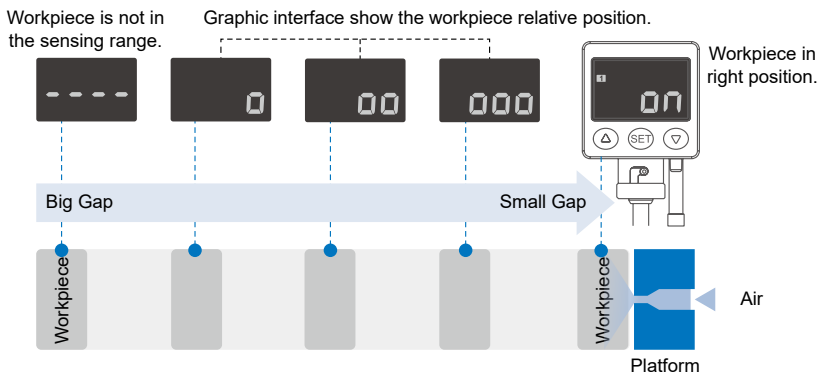

IP65 compliance



Reference gap easy setting

- To set the reference gap by press up + down at the same time.

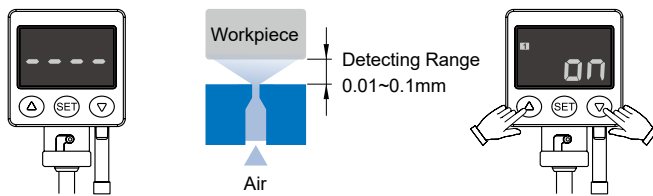

Repeatability : $\pm 5 \mu\text{m}$

- The higher repeatability is, the more guarantee is.

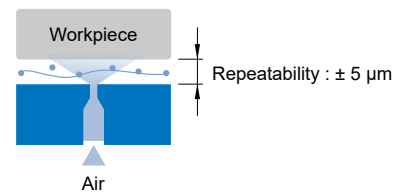

The gap cause by shavings can be detectable

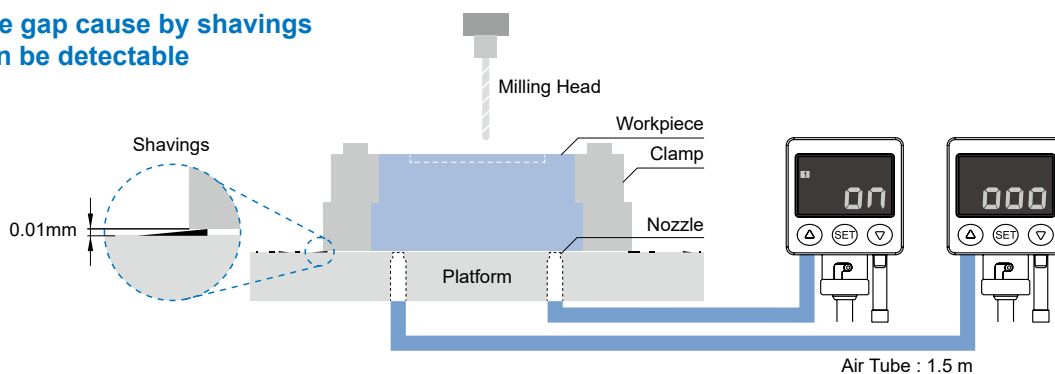

Specification

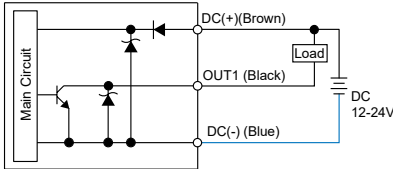
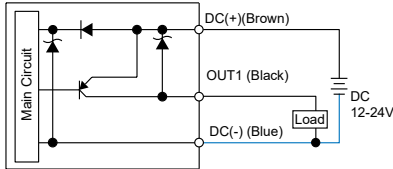
Model	MPGS01-□-02	MPGS01-□-04
Detection Distance	0.01 ~ 0.10 mm	
Operating Pressure Range	250 ~ 350 kPa	
Withstand Pressure	600 kPa	
Fluid	Clean air, Non-corrosive / Non-flammable gas *1	
Power Supply Voltage	12 ~ 24 V DC ± 10 %, Ripple (P-P) ≤ 10 %	
Current Consumption	≤ 20 mA	
Switch Output	1 NPN : open collector 1 output Max. Load Current : 125 mA Max. Supply Voltage : 30 V DC Residual Voltage : ≤ 1.5 V	1 PNP : open collector 1 output Max. Load Current : 125 mA Max. Supply Voltage : 24 V DC Residual Voltage : ≤ 1.5 V
Consumption Flow Rate	≤ 16 L/min @ 300 kPa	
Repeatability	±5 μm	
Hysteresis	Adjustable 1 ~ 30 digits	
Output Short Circuit Protection	Yes	
Display	3 ½ digital, 7 segment LCD display (White) (Sampling rate : 5 times / sec.)	
Switch on Indicator	White Indicator 1 : OUT	
Detection Nozzle	ø1.5 mm *2	
Environment	Enclosure	IP65
	Ambient Temp. Range	Operation: 0 ~ 50 °C, Storage: -10 ~ 60 °C (No condensation or freezing)
	Ambient Humidity Range	Operation / Storage: 35 ~ 85 % RH (No condensation)
	Withstand Voltage	1000 V AC 1-min (between case and lead wire)
	Insulation Resistance	≥ 50 MΩ (at 500 V DC, between case and lead wire)
	Vibration	Total amplitude 1.5 mm or 10 G, 10 Hz ~ 55 Hz ~ 10 Hz scan for 1 minute, 2 hours each direction of X, Y and Z
Piping Specifications	Supply Port	F1C : Rc1/8" *3
	Detection Port	
Lead wire	ø4 Oil-resistance cable (PVC) - 26 AWG (0.15 mm ²) - 3 cores	
Weight (with 2 meter lead wire)	Approx. 115 g	
Circuit wiring diagrams		

*1. Please use air filter to clean air (5 μm or less) and install precision regulator.

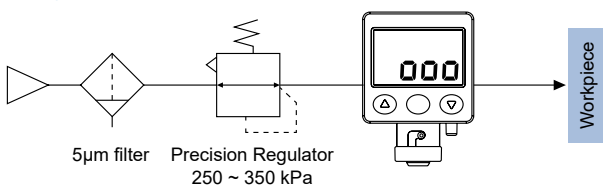

*2. Detection nozzle

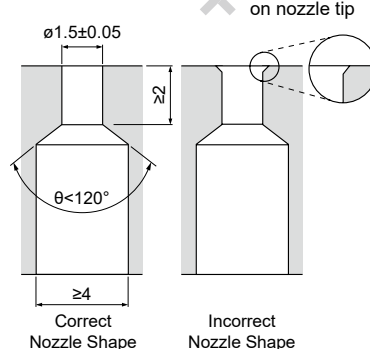

*3. Back side of product

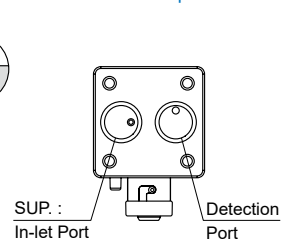

*4. Dustproof protector must be installed to maintain IP65.

GAP SENSOR

Order example

MPGS01 - G - 02 - F1C

MODEL

RATED DISTANCE RANGE

G: 0.01 ~ 0.10 mm

OUTPUT METHOD

02: 1 NPN output
04: 1 PNP output

PRESSURE PORT

F1C: Rc1/8"

Panel instructions

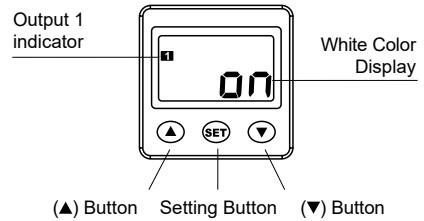

Mounting accessories (Option)

MP - A18

MODEL

OPTION PARTS

A18: Mounting bracket
A19: Mounting bracket
B3: Panel adapter
C3: Panel adapter + Front protective lid

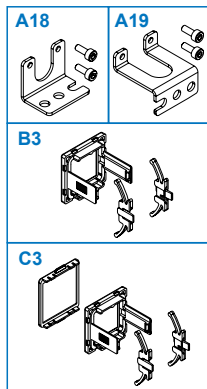

Installation precautions

- When mounting, don't apply tool fix to the body, it will damage the sensor.
- Over tightening may cause damages to the port thread, mounting bracket and pressure sensor. Under tightening may result loosen or leakage.

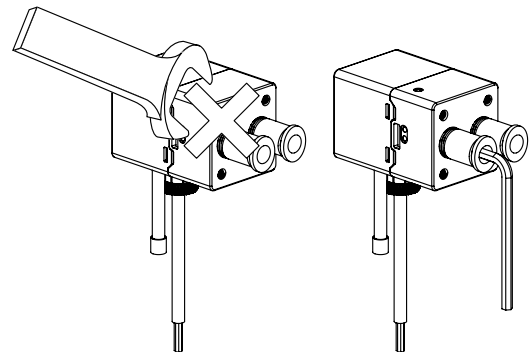

* Internal Hex Straight Tube-to-Tube Adaptors are recommended.

Dimensions

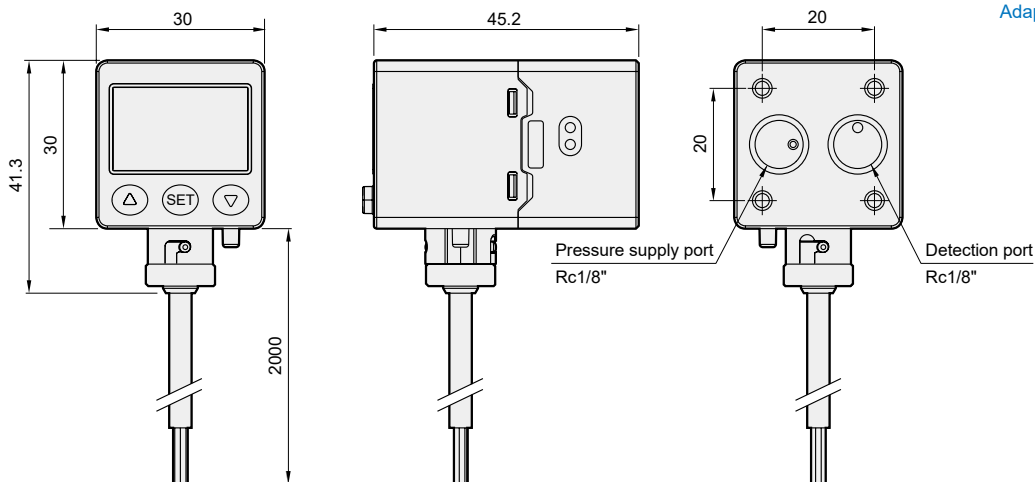

Mounting accessories

Mounting bracket

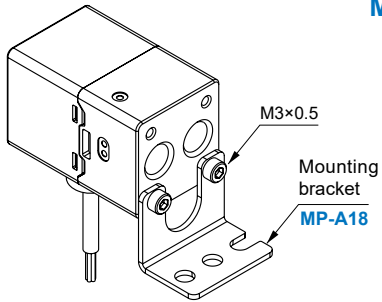

MP-A18

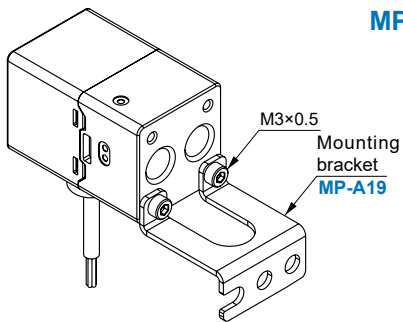
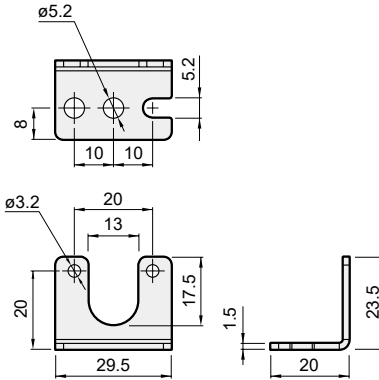

MP-A19

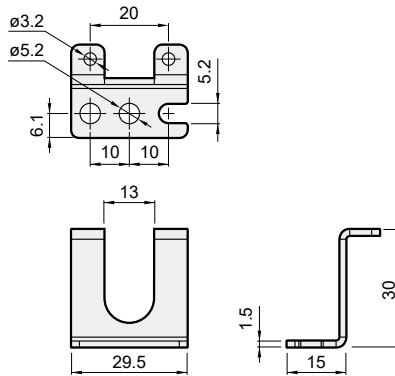

Dustproof

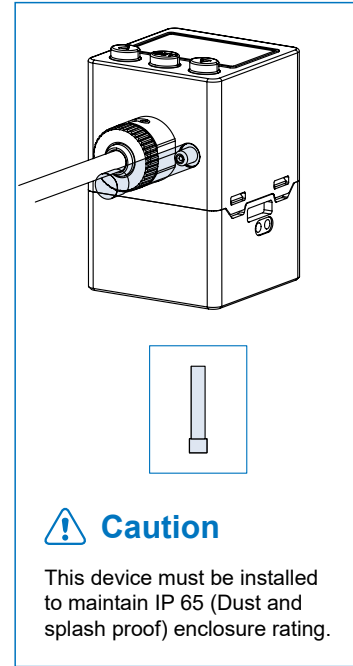

Panel type

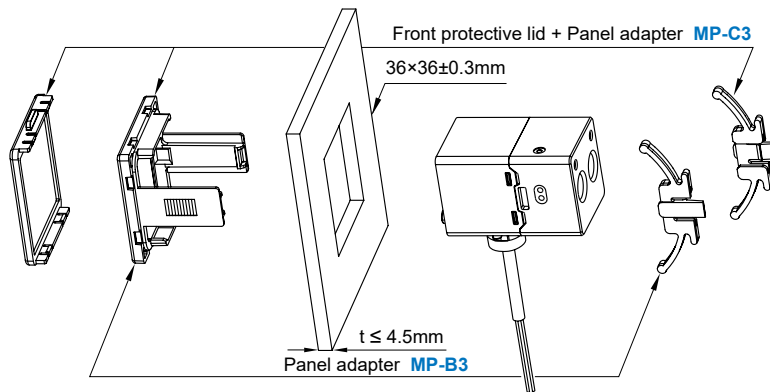

Front protective lid

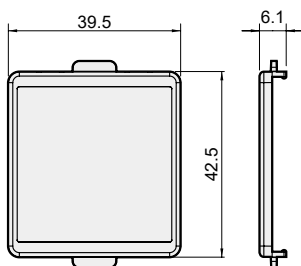

Panel adapter

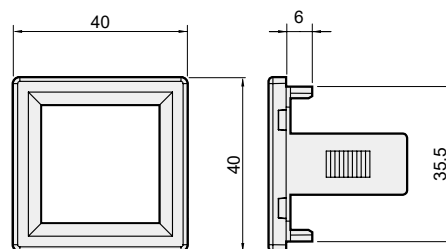



User manual



Features

- 3 color digital LCD display.
- Programmable pressure unit: kPa, MPa, kgf/cm², bar, psi, mmHg, inHg.
- Dual LCD display allow setting value to be displayed.
- Key lock indicator.
- Analog output : 1 ~ 5 V or 4 ~ 20 mA
- Sensor input : 1 ~ 5 V or 4 ~ 20 mA
- 12 pressure ranges for transducer.

Features highlight

3-color digital LCD display

- Main display color change with output status.

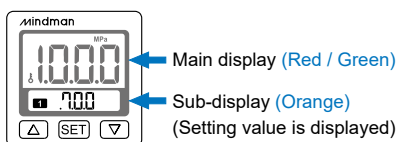

Easy unit identification

- Conversion unit is on display and easy to read.

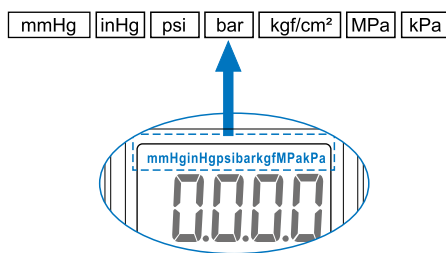

Save installation space

- Actual dimension after installation

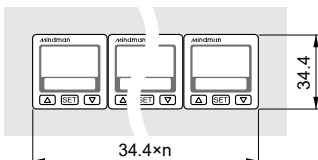

Key-lock function

- Key-lock icon is shown on the display when the function is enabled.

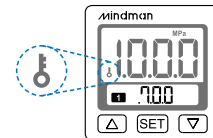

Specification

Model	MP400													
Sensor type	S-0	S-1	S-2	S-3	S-4	S-5	S-6	S-7	S-8	S-9	S-10	S-11	S-12	
Rated pressure range	Self-Setting *1	-101.3 ~ 0 kPa	0 ~ 100 kPa	0 ~ 2 kPa	0 ~ 5 kPa	-100 ~ 100 kPa	-101 ~ 500 kPa	0 ~ 1 MPa	0 ~ 2 MPa	0 ~ 2.5 MPa	0 ~ 10 MPa	0 ~ 25 MPa	0 ~ 40 MPa	
Setting pressure range		-101.3 ~ 10 kPa	-10 ~ 100 kPa	-0.2 ~ 2 kPa	-0.5 ~ 5 kPa	-100 ~ 100 kPa	-101 ~ 500 kPa	-0.1 ~ 1 MPa	-0.1 ~ 2 MPa	-0.1 ~ 2.5 MPa	0 ~ 10 MPa	0 ~ 25 MPa	0 ~ 40 MPa	
Set Pressure Range (Auto-Shift Input)	—	-101.3 ~ 101.3 kPa	-100 ~ 100 kPa	-2 ~ 2 kPa	-5 ~ 5 kPa	-100 ~ 100 kPa	-500 ~ 500 kPa	-1 ~ 1 MPa	-2 ~ 2 MPa	-2.5 ~ 2.5 MPa	-10 ~ 10 MPa	-25 ~ 25 MPa	-40 ~ 40 MPa	
Set pressure resolution	Self-Setting	KPa	0.1	0.1	0.01	0.01	0.1	1	—	—	—	—	—	
		MPa	—	—	—	—	—	—	0.001	0.01	0.01	0.01	0.1	0.1
		kgf/cm ² / bar	0.001	0.001	—	—	0.001	0.01	0.01	0.1	0.1	0.1	1	1
		psi	0.01	0.01	—	—	0.01	0.1	0.1	1	1	1	1 *2	1 *2
		InHg	0.1	—	—	—	0.1	—	—	—	—	—	—	—
mmHg	1	—	0.1	0.1	1	—	—	—	—	—	—	—		
Power supply voltage	12 ~ 24 V DC ± 10 %, Ripple (P-P) ≤ 10 %													
Current consumption	≤ 40 mA (with no load)													
Sensor input	1 ~ 5 V or 4 ~ 20 mA													

Specification

Model	MP400
Switch output	<div style="display: flex; justify-content: space-between;"> <div style="width: 45%;"> 2 NPN : open collector 2 outputs Max. Load Current : 125 mA Max. Supply Voltage : 30 V DC Residual Voltage : ≤ 1.5 V </div> <div style="width: 45%;"> 2 PNP : open collector 2 outputs Max. Load Current : 125 mA Max. Supply Voltage : 24 V DC Residual Voltage : ≤ 1.5 V </div> </div>
Repeatability	± 0.1 % F.S. ± 1 digit
Hysteresis	Adjustable *3
<div style="display: flex; justify-content: space-between;"> <div style="width: 30%;"> One point set mode Hysteresis mode Window comparator mode </div> <div style="width: 65%;"></div> </div>	
Response time	≤ 2.5 ms (Chattering-proof function : 25 ms, 100 ms, 250 ms, 500 ms, 1000 ms and 1500 ms selectable)
Output short circuit protection	Yes
Display	3 ½ digital, 7 segment LCD display (Red / Green / Orange) (Sampling rate : 5 times / sec.)
Indicator accuracy	± 1 % F.S. ± 1 digit (Ambient temperature : 25 ± 3 °C)
Switch on indicator	Orange Indicator 1 : OUT1 & Orange Indicator 2 : OUT2
Analog Output (Voltage Output) *4	Output Voltage : 1 ~ 5 V ± 2 % F.S. (within rated pressure range) Linearity : ± 1 % F.S. Output Impedance : about 1 kΩ
Analog output (Current Output) *5	Output Current : 4 ~ 20 mA ± 2 % F.S. (within rated pressure range) Linearity : ± 1 % F.S. Max. Load Impedance : 300 Ω at power supply of 12 V, 600 Ω at power supply of 24 V Min. Load Impedance : 50 Ω
Enclosure	IP40
Ambient temp. Range	Operation : 0 ~ 50 °C, storage : -10 ~ 60 °C (No condensation or freezing)
Ambient humidity range	Operation / Storage : 35 ~ 85 % RH (No condensation)
Withstand voltage	1000 V AC in 1-min (between case and lead wire)
Insulation resistance	≥ 50 MΩ (at 500 V DC, between case and lead wire)
Vibration	Total amplitude 1.5 mm or 10 G, 10 Hz ~ 55 Hz ~ 10 Hz scan for 1 minute, 2 hours each direction of X, Y and Z
Shock	100 m/s ² (10 G), 3 times each in direction of X, Y and Z
Temperature characteristic	± 0.5 % F.S. of detected pressure (25 °C) at temp. (Range of 0 ~ 50 °C)
Lead wire	ø4 Oil-resistance cable (PVC) - 26 AWG (0.15 mm ²) - 5 cores
Weight (with 2 meter lead wire)	Approx. 67 g

*1. S-0 : Set the sensor range (1999 ~ -1999) by self. The decimal place can be adjusted.
 *2 : If set pressure unit is psi, the value requires to ten multiply by display value.

*3 : Hysteresis value is adjustable within 1 ~ 8 digits for one point set mode and window comparator mode.
 *4 : If analog voltage output is selected, the analog current output cannot be selected at the same time.
 *5 : If analog current output is selected, the analog voltage output cannot be selected at the same time.

Output circuit wiring graph

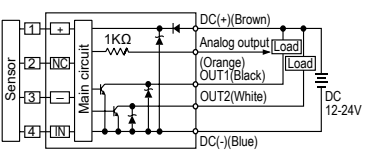
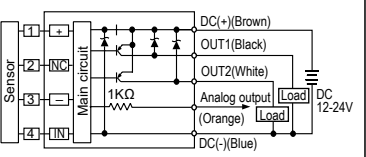
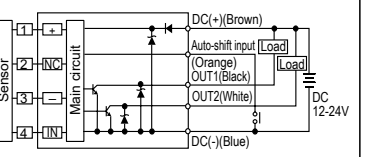
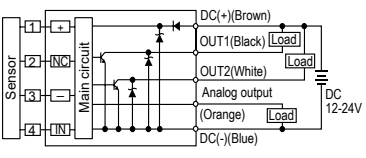
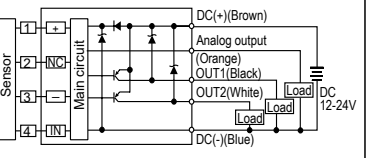
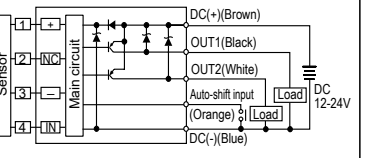
Model	MP4□0-010	MP4□0-030	MP4□0-05
Connect diagram			
Output method	2 NPN + Analog Output (1 ~ 5 V)	2 PNP + Analog Output (1 ~ 5 V)	2 NPN Output + Auto-shift input
Model	MP4□0-011	MP4□0-031	MP4□0-07
Connect diagram			
Output method	2 NPN + Analog Output (4 ~ 20 mA)	2 PNP + Analog Output (4 ~ 20 mA)	2 PNP Output + Auto-shift input

MP400 Dimensions

MULTI-CONTROLLER



Order example

MP410 — 010

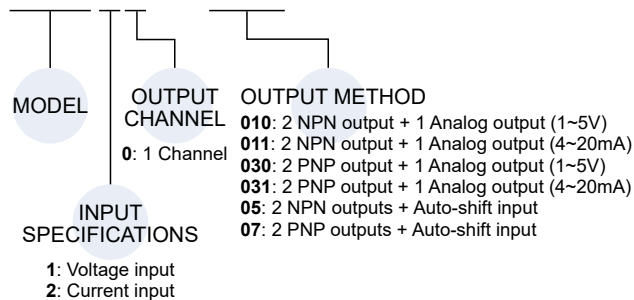

Panel instructions

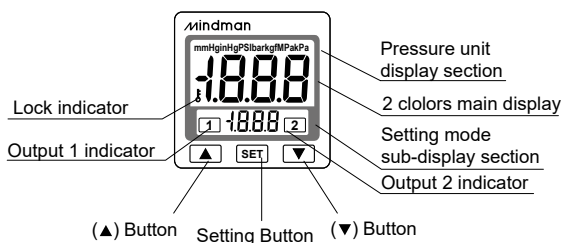

Dimensions

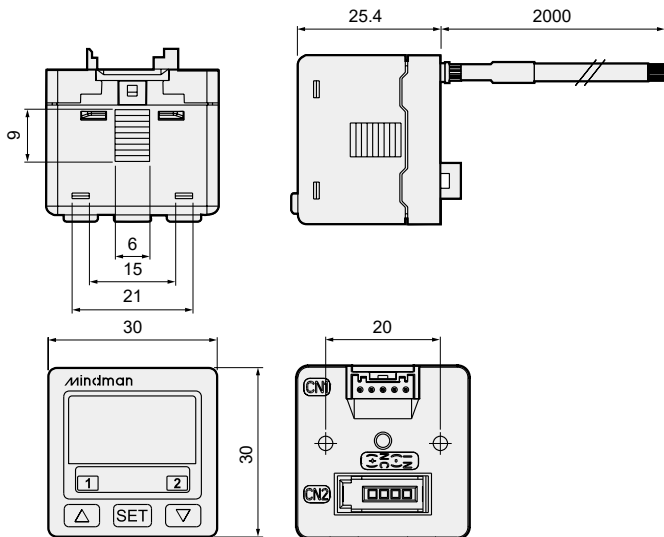

Panel opening for multiple pressure controller.

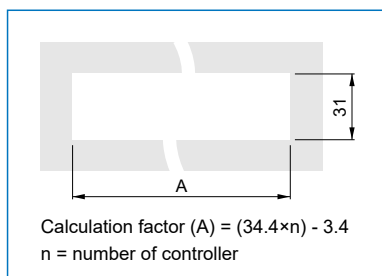

Mounting accessories (Option)

MP — A8

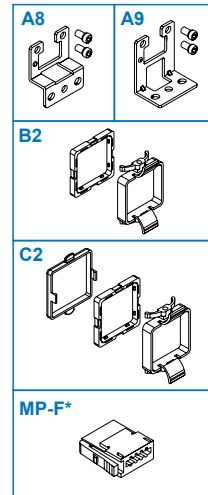
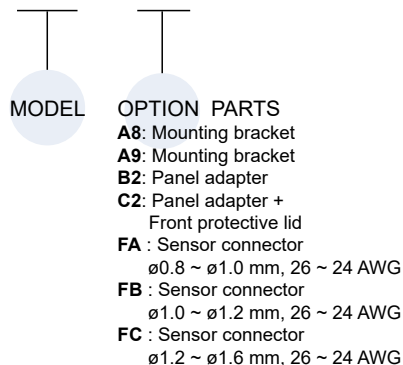

Connector

Pin No.	Line color	Content
①	Brown	DC+
②	—	No used
③	Blue	DC-
④	Black	IN

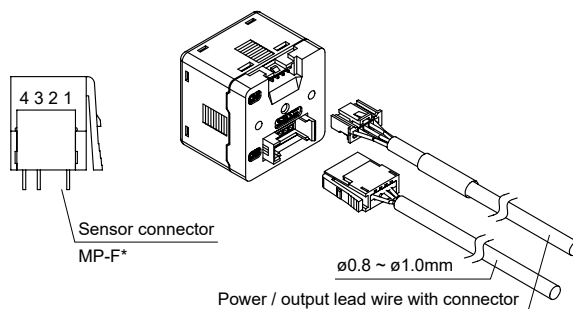

Pin No.	Line color	Content
①	Brown	DC+
②	Orange	Analog or auto shift
③	White	OUT 2
④	Black	OUT 1
⑤	Blue	DC-

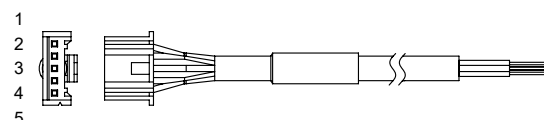

Mounting bracket

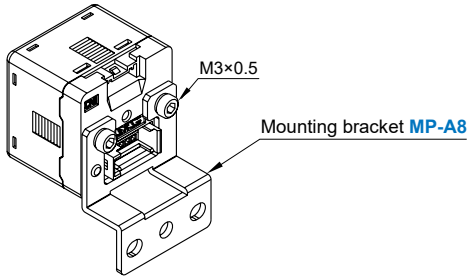

MP-A8

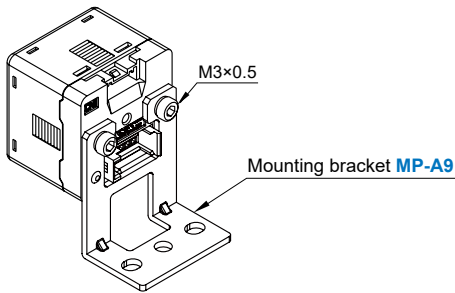
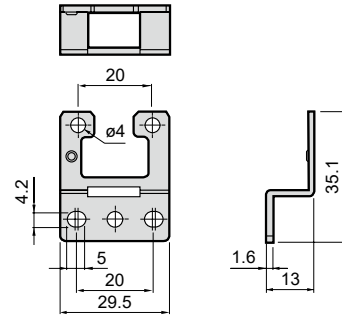

MP-A9

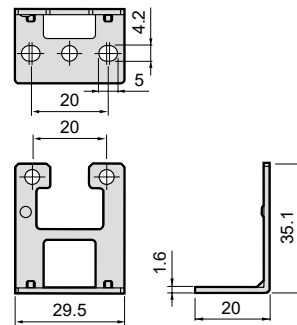

Panel type

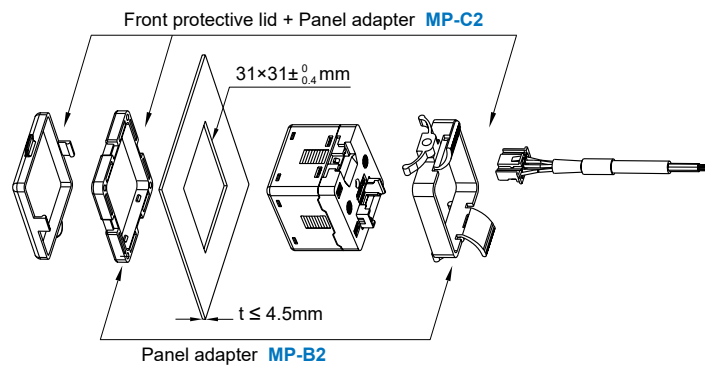

Front protective lid

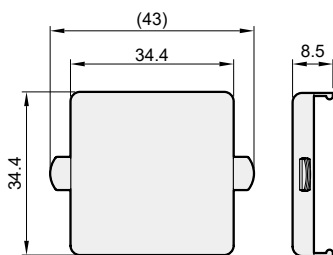

Panel adapter

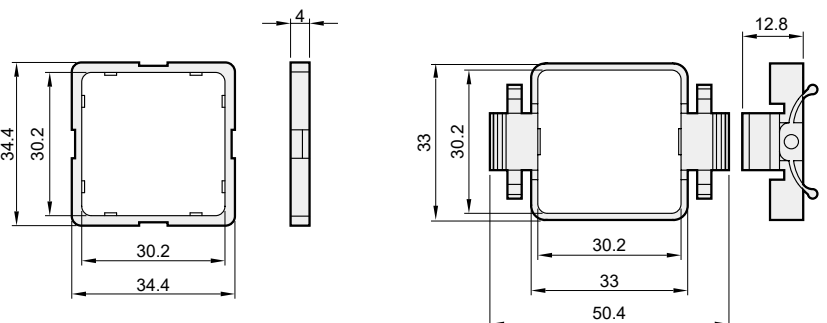

MF01 / 02 series

DIGITAL FLOW SENSOR



MF01 user manual



MF02 user manual



Selection table



Feature

- Display can be vertically inverted. To set and watch monitor easily.
- 3-Color & 7 segment LCD display.
- 8 digit accumulated flow rate display.
- Real-time monitoring.
- RS485 Modbus control.

Symbol



MF01 Specification

Model		005	010	050	100	500	101	201	
Sensor element	Flow	Measured flow rate range							
	Flow direction	Unidirection							
Display	Display	4 digital (Flow) / 8 digital (Accumulated flow), 7 segment LCD display (Red / Green / Orange)							
	Instant flow rate	Display range	0 ~ 525 mL/min	0 ~ 1050 mL/min	0 ~ 5.25 L/min	0 ~ 10.50 L/min	0 ~ 52.5 L/min	0 ~ 105.0 L/min	0 ~ 210 L/min
		Min. setting scale	1 mL/min		0.01 L/min		0.1 L/min		1 L/min
	Accumulated Flow	Display range	99999999 mL		999999.99 L		9999999.9 L		99999999 L
		Min. Setting Scale *1	1 mL		0.01 L		0.1 L		1 L
Switch output	Accumulated pulse output *1	5 mL/Pulse	10 mL/Pulse	0.05 L/Pulse	0.1 L/Pulse	0.5 L/Pulse	1 L/Pulse	2 L/Pulse	
Port size	R6, F1C	•	•	•	•	•			
	R8, F4C						•	•	
Weight (with 2 meter lead wire)		Approx. 109.3 g (ø6 port) ; Approx. 112.7 g (ø8 port) ; Approx. 118 g (Rc1/4 port) ; Approx. 128.5 g (Rc1/8 port)							

*1. When the display unit is CFM, ft³, the actual flow is the display value×10⁻².

MF02 Specification

Model		501	102	202	
Sensor element	Measured flow rate range	2 ~ 500 L/min	5 ~ 1000 L/min	10 ~ 2000 L/min	
	Flow direction	Unidirection			
Display	Display	4 digital (Flow) / 8 digital (Accumulated flow), 7 segment LCD display (Red / Green / Orange)			
	Instant flow rate	Display range	0 ~ 525 L/min	0 ~ 1050 L/min	0 ~ 2100 L/min
		Min. setting scale	1 L/min		
	Accumulated flow	Display range	99999999 L		
		Min. setting scale	1 L		
Switch output	Accumulated pulse output *1	5 L/Pulse	10 L/Pulse	10 L/Pulse	
Port size	Rc1/2, F7C	•	•		
	G1/2, F9C	•	•		
	Rc3/4, F10C			•	
	G3/4, F12C			•	
Weight (without 2 meter lead wire)		Approx. 281.7 g (500 / 1000 L) ; Approx. 344 g (2000 L)			

(Continued)

MF01 & 02 Specification

Model	MF01	MF02	
Fluid	Dry air, N ₂ , Non-corrosive / Non-flammable gas		
Accuracy	Guaranteed range	2 ~ 100 % F.S.	
	Indicator accuracy	± 3 % F.S. ± 1 digit *1	
	Analog output accuracy	± 5 % F.S. *1	
	Repeatability	± 1 % F.S. ± 1 digit *2	± 1 % F.S. ± 1 digit (± 2 % F.S. when response time is set to 50 ms) *2
	Linearity	± 3 % F.S. *2	
	Temp. characteristic	± 2 % F.S. (15 ~ 35 °C); ± 5 % F.S. (0 ~ 15 °C, 35 ~ 50 °C) (compare with *3)	± 5 % F.S. (compare with *3)
	Pressure characteristic	± 5 % F.S. ± 1 digit *3	
Switch output	Switch output	2 NPN : open collector 2 outputs Max. Load Current : 125 mA Max. Supply Voltage : 28 V DC Voltage Drop : ≤ 1.5 V	2 PNP : open collector 2 outputs Max. Load Current : 125 mA Max. Supply Voltage : 24 V DC Voltage Drop : ≤ 1.5 V
	Response time	800 ms (50 ms, 80 ms, 120 ms, 200 ms, 400 ms, 1500 ms selectable)	
	Output mode	Hysteresis Mode, Window Comparator Mode, Accumulated Output, Accumulated Pulse Output	
	Hysteresis	Adjustable	
	Output short circuit protection	Yes	
Analog output	Voltage output	Voltage Output Range: 1 ~ 5 V , Output Impedance: 1 KΩ	
	Current output	Current Output Range: 4 ~ 20 mA, Load Impedance: ≤ 300 Ω	
	Response time	≤ 100 ms	
External input	Non-voltage input, < 0.4 V, ≥ 30 ms		
Communication interface	RS485 *4,5		
Power	Power supply voltage	12 ~ 24 V DC ± 10 % , Ripple (P-P) ≤ 10 %	
	Current consumption	≤ 50 mA	
Environment	Working pressure range	-0.09~0.8 MPa	0~1 MPa
	Withstand pressure	1 MPa	1.5 MPa
	Enclosure	IP40	
	Working Fluid Temp.	0 ~ 50 °C (No condensation or freezing)	
	Ambient Temp. Range	Operation: 0 ~ 50°C, Storage: -10 ~ 60°C (No condensation or freezing)	
	Ambient Humidity Range	Operation / Storage: 35 ~ 85% R.H. (No condensation)	
	Insulation Resistance	≥ 50 MΩ (500 V DC, between case and lead wire)	≥ 2 MΩ (50 V DC, between case and lead wire)
	Withstand Voltage	1000 V AC 1-min (between case and lead wire)	250 V AC 1-min (between case and lead wire)
	Vibration	Total amplitude 1.5 mm or 10 G, 10 Hz ~ 55 Hz ~ 10 Hz scan for 1 minute, 2 hours each direction of X, Y and Z	
	Shock	100 m/s ² (10 G), 3 times each in direction of X, Y and Z	
EMC	IEC 61000-6-2, IEC 61000-6-4		
Lead wire	ø4 Oil-resistance cable (PVC) - 26 AWG (0.15 mm ²) - 6 cores		

*1. Condition: Inlet pressure: 300 kPa (MF01), 600 kPa (MF02), Outlet pressure: 1 atmospheric pressure, 25 °C

*2. Condition: Outlet pressure: 1 atmospheric pressure, 25 °C.

*3. MF01: -0.09 ~ 0.8 MPa, Outlet pressure: 1 atmospheric pressure, 25 °C.

MF02: 0 ~ 1.0 MPa, Outlet pressure : 1 atmospheric pressure, 25 °C

*4. This function only available for output specification -02 and -04.

*5. 4 data reading per time.

MF01 / 02 Output circuit wiring graph

DIGITAL FLOW SENSOR



Output circuit wiring graph

Model	MF01/02-□-010	MF01/02-□-011	MF01/02-□-02
Connect diagram			
Output method	NPN output / Analog voltage output / External input	NPN output / Analog current output / External input	NPN output / RS-485 MODBUS mode
Model	MF01/02-□-030	MF01/02-□-031	MF01/02-□-04
Connect diagram			
Output method	PNP output / Analog voltage output / External input	PNP output / Analog current output / External input	PNP output / RS-485 MODBUS mode

* Procedure to wiring RS485 products : To prevent product damage due to short circuit , MUST do RS485 line connection BEFORE power line connection.

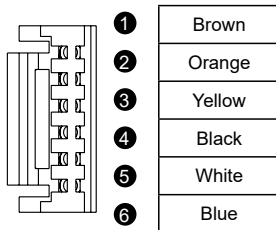

Pin no.	Line color	Content
1	Brown	Power supply (12 ~ 24 V DC)
2	Orange	Analog voltage output: 1 ~ 5 V
		Analog current output: 4 ~ 20 mA
3	Yellow	External input
		RS485 (A-)
4	Black	Output 1 (Max. load current: 125 mA)
5	White	Output 2 (Max. load current: 125 mA)
6	Blue	0 V (GND)

DIGITAL FLOW SENSOR

Order example

MF02 – 501 – 010 – F7C

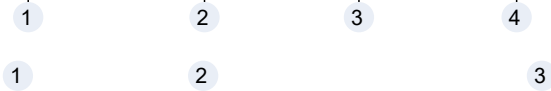

MODEL	FLOW RATE RANGE	OUTPUT METHOD	PORT SIZE
MF01	005: 500 (ml/min) 010: 1000 (ml/min) 050: 5 (l/min) 100: 10 (l/min) 500: 50 (l/min)	010: 2 NPN output + 1 Analog output (1~5V) 011: 2 NPN output + 1 Analog output (4~20mA) 02 : 2 NPN output + RS485 030: 2 PNP output + 1 Analog output (1~5V) 031: 2 PNP output + 1 Analog output (4~20mA) 04 : 2 PNP output + RS485	R6: ø6 mm F1C: Rc1/8", with internal threads
	101: 100 (l/min) 201: 200 (l/min)		R8: ø8 mm F4C: Rc1/4", with internal threads
MF02	501: 500 (l/min) 102: 1000 (l/min)		F7C: Rc1/2" F9C: G1/2"
	202: 2000 (l/min)		F10C: Rc3/4" F12C: G3/4"

Mounting accessories

MP – A27



MODEL	OPTION PARTS
MF01	A26: Mounting bracket B4: Panel adapter C4: Panel adapter + Front protective lid
MF02	A27: Mounting bracket, for 501, 102 A28: Mounting bracket, for 202

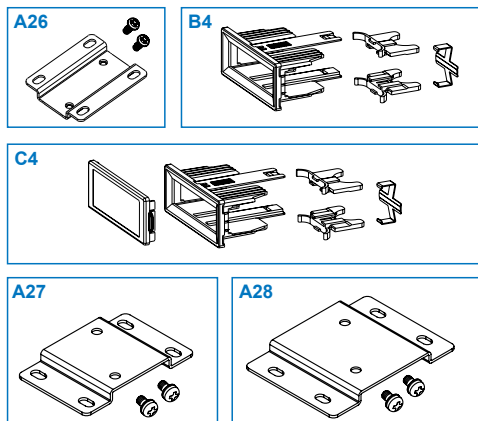

Name and functions of individual parts

Panel description

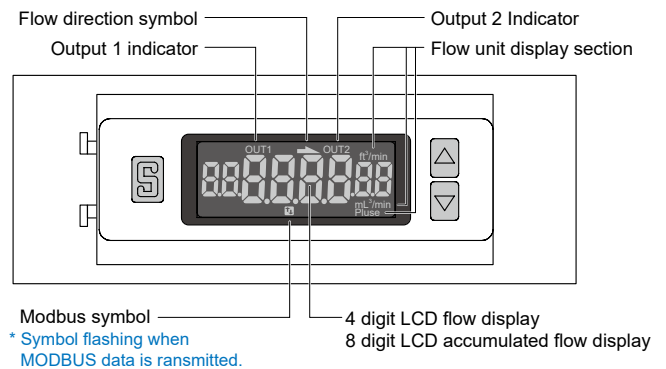

Body description

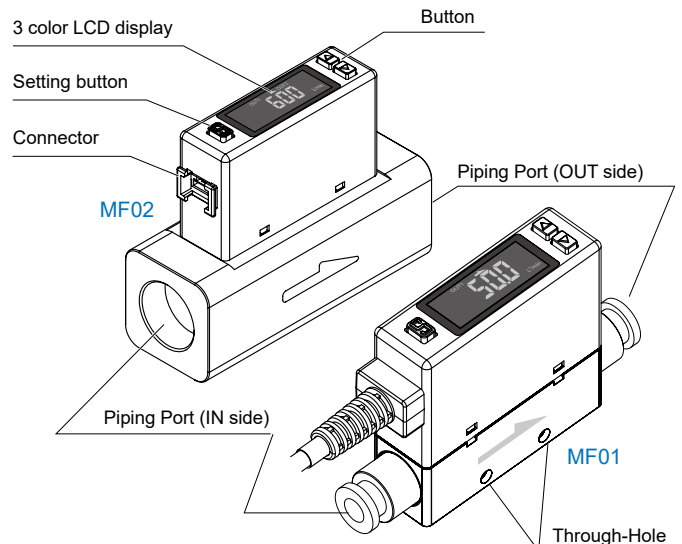

MF01 Dimensions

DIGITAL FLOW SENSOR



Port size

R6 (ø6)

R8 (ø8)

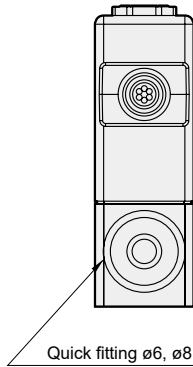

Code Tube I.D.	A (mm)
ø8	92.2
ø6	83

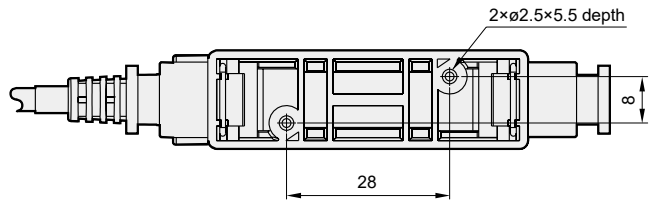
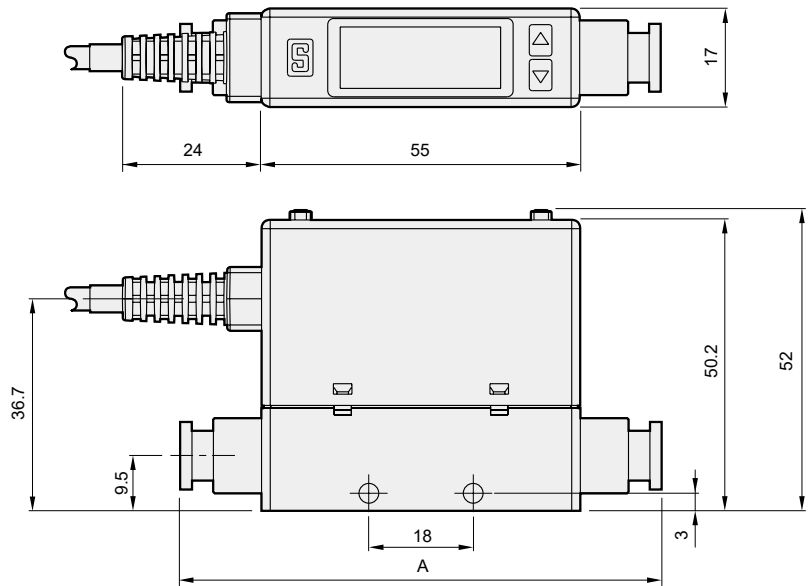

Port size

F1C (Rc1/8")

F4C (Rc1/4")

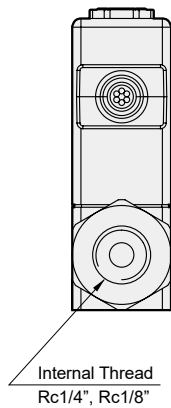

Code Thread	B (mm)
Rc1/8"	76.2
Rc1/4"	76.2

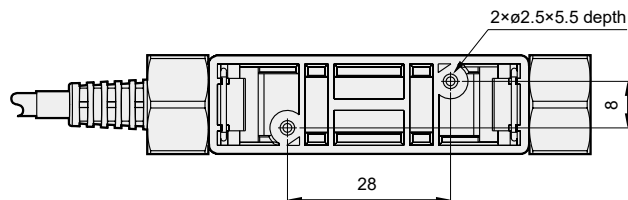
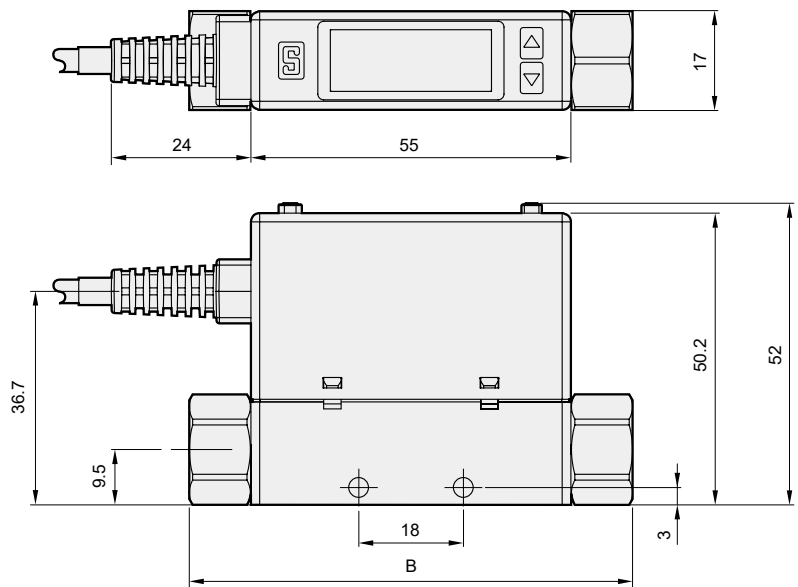

Mounting bracket

MP-A26

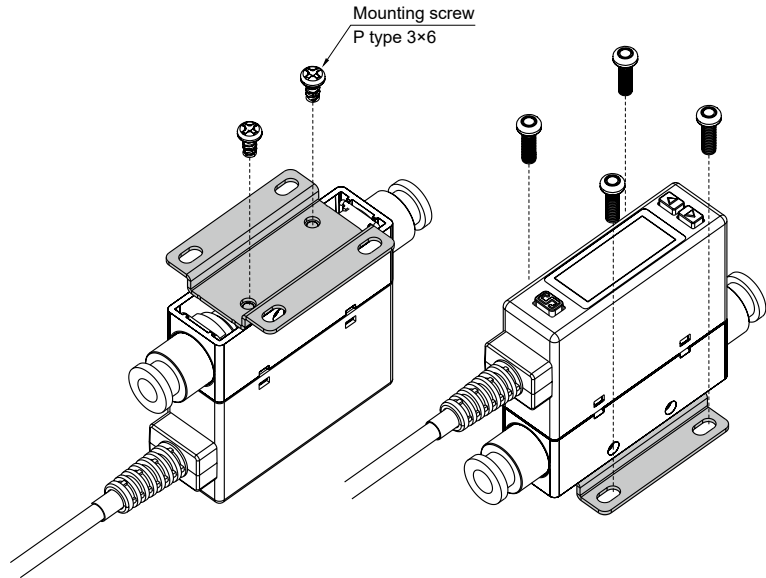
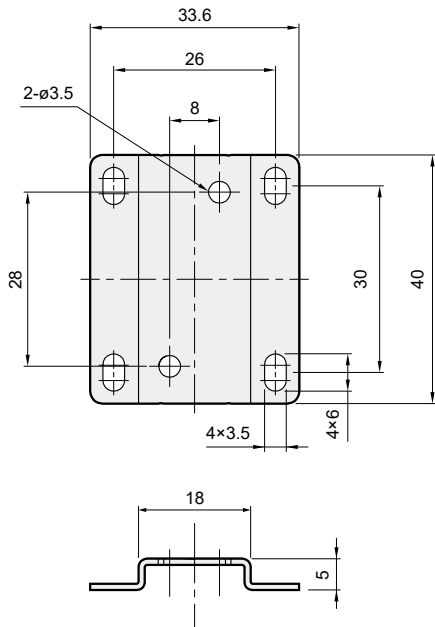

Panel type

Front protective lid + Panel adapter MP-C4

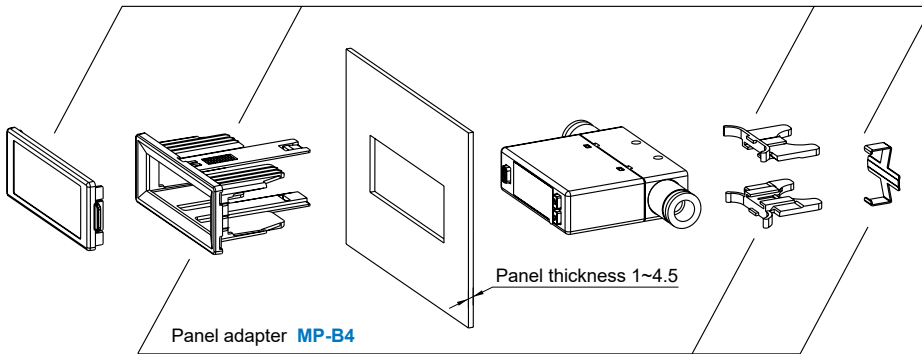

Panel cut dimensions

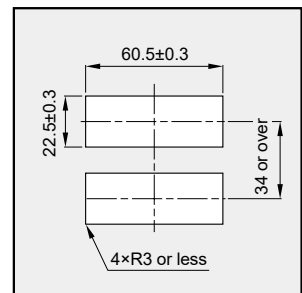

Front protective lid

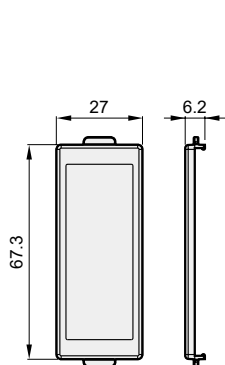

Panel adapter

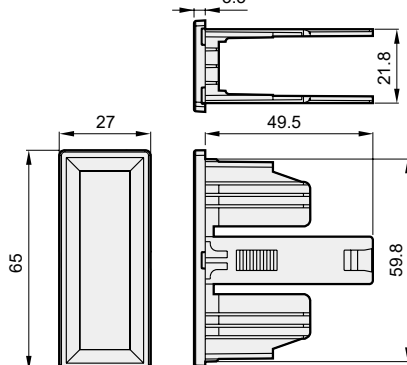

Panel adapter

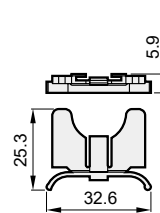

Panel adapter

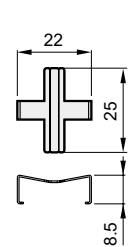

MF02 Dimensions

DIGITAL FLOW SENSOR



Dimensions

Port size
F7C (Rc1/2")
F9C (G1/2")

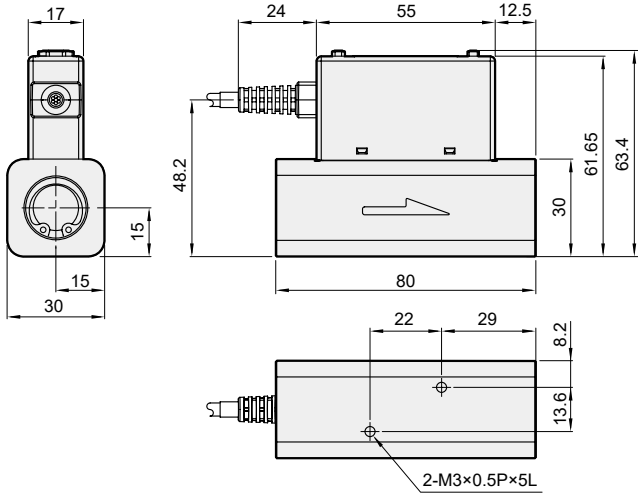

Port size
F10C (Rc3/4")
F12C (G3/4")

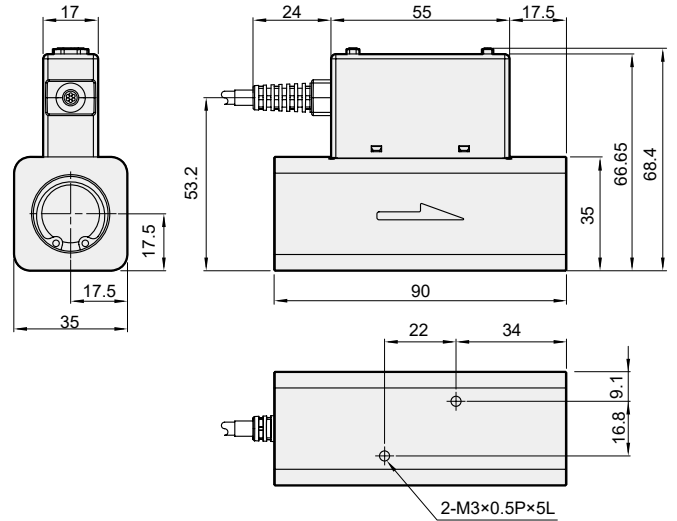

Mounting bracket

MP-A27

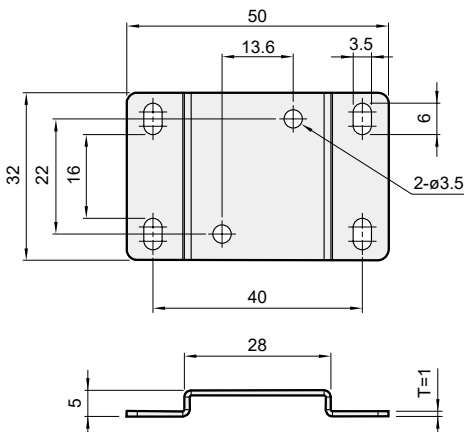
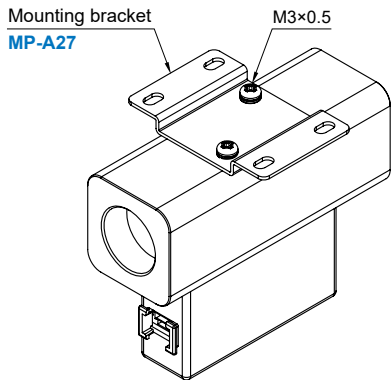

MP-A28

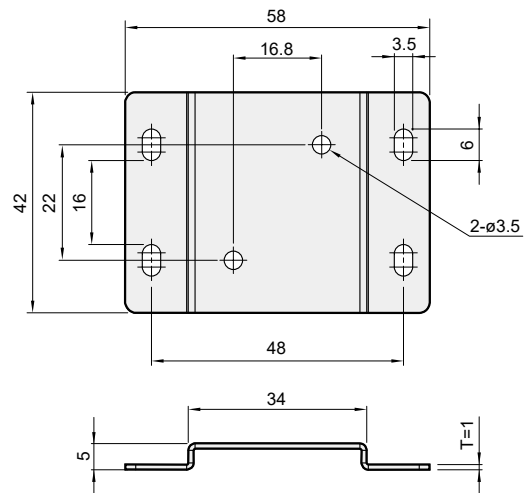
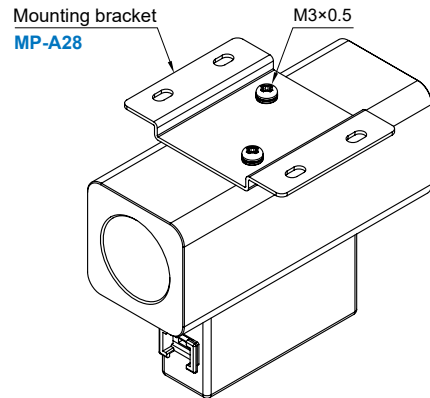

MFP01 / 02 series

FLOW & PRESSURE SENSOR



MFP01 user manual



MFP02 user manual



Selection table



Feature

- Flow and pressure 4 digit, 7 segment dual LCD display.
- 8 digit accumulated flow rate display.
- Real-time monitoring.
- RS485 Modbus control.

Symbol

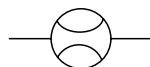

MFP01 Specification

Model		005	010	050	100	500	101	201		
Sensor element	Flow	Measured flow rate range		0 ~ 500 mL/min	0 ~ 1000 mL/min	0 ~ 5 L/min	0 ~ 10 L/min	0 ~ 50 L/min	0 ~ 100 L/min	0 ~ 200 L/min
		Flow direction								Unidirection
	Pressure	Rated pressure range								-90 ~ 800 kPa
Display		4 digital × 4 digital, 7 segment LCD display (Red / Green / Orange)								
Display	Instant flow rate	Display range		0 ~ 525 mL/min	0 ~ 1050 mL/min	0 ~ 5.25 L/min	0 ~ 10.50 L/min	0 ~ 52.5 L/min	0 ~ 105.0 L/min	0 ~ 210 L/min
		Min. setting scale	LPM	1 mL/min		0.01 L/min		0.1 L/min		1 L/min
	CFM *1		0.01 ft ³ /min		0.1 ft ³ /min		1 ft ³ /min			
Display	Accumulated Flow	Display range		99999999 mL		999999.99 L		9999999.9 L		99999999 L
		Min. Setting Scale *1	1 mL		0.01 L		0.1 L		1 L	
	0.01 ft ³		0.1 ft ³		1 ft ³					
Switch output		5 mL/Pulse	10 mL/Pulse	0.05 L/Pulse	0.1 L/Pulse	0.5 L/Pulse	1 L/Pulse	2 L/Pulse		
Accumulated pulse output *1		0.02 ft ³ /Pulse	0.04 ft ³ /Pulse	0.2 ft ³ /Pulse	0.4 ft ³ /Pulse	2 ft ³ /Pulse	4 ft ³ /Pulse	7 ft ³ /Pulse		
Port Size	R6, F1C	•	•	•	•	•				
	R8, F4C						•	•		
Weight (with 2 meter lead wire)		Approx. 109.3 g (ø6 port) ; Approx. 112.7 g (ø8 port) ; Approx. 118 g (Rc1/4" port) ; Approx. 128.5 g (Rc1/8" port)								

*1. When the display unit is CFM, ft³, the actual flow is the display value×10⁻².

MFP02 Specification

Model		501	102	202		
Sensor element	Flow	Measured flow rate range		2 ~ 500 L/min	5 ~ 1000 L/min	10 ~ 2000 L/min
		Flow direction				Unidirection
	Pressure	Rated pressure range				-90 ~ 1000 kPa
Display		4 digital × 4 digital, 7 segment LCD display (Red / Green / Orange)				
Display	Instant flow rate	Display range		0 ~ 525 L/min	0 ~ 1050 L/min	0 ~ 2100 L/min
		Min. setting scale	LPM	1 L/min		
	CFM		0.1 ft ³ /min			
Display	Accumulated Flow	Display range		99999999 L		
		Min. Setting Scale	1 L		1 ft ³	
	1 ft ³					
Switch output		5 L/Pulse	10 L/Pulse	10 L/Pulse		
Accumulated pulse output *1		20 ft ³ /Pulse	40 ft ³ /Pulse	40 ft ³ /Pulse		
Port Size	Rc1/2, F7C / G1/2, F9C	•	•			
	Rc3/4, F10C / G3/4, F12C			•		
Weight (without 2 meter lead wire)		Approx. 281.7 g (500 / 1000 L) ; Approx. 344 g (2000 L)				

(Continued)

MFP01 / 02 Specifications

FLOW & PRESSURE SENSOR



MFP01 / 02 Specification

Model		MFP01	MFP02	
Fluid		Dry air, N ₂ , Non-corrosive / Non-flammable gas		
Display	Display range	-100 ~ 1000 kPa		
	Pressure Display	kPa	1	
		Min. Setting Scale	kgf/cm ²	0.01
		bar / psi	0.01 / 0.1	
Accuracy	Guaranteed range	2 ~ 100 % F.S.		
	Indicator accuracy	± 3 % F.S. ± 1 digit *1		
	Analog output accuracy	± 5 % F.S. *1		
	Flow	Repeatability	± 1 % F.S. ± 1 digit *2	± 1 % F.S. ± 1 digit (± 2 % F.S. when response time is set to 50 ms) *2
		Linearity	± 3 % F.S. *2	
	Temp. characteristic	± 2 % F.S. (15 ~ 35 °C); ± 5 % F.S. (0 ~ 15 °C, 35 ~ 50 °C) (compare with *2)		
	Pressure characteristic	± 5 % F.S. ± 1 digit *3		
	Pressure	Guaranteed range	0 ~ 100 % F.S.	
		Indicator accuracy	± 2 % F.S. ± 1 digit *4	
		Analog output accuracy	± 2.5 % F.S. *4	
		Repeatability	± 0.2 % F.S. ± 1 digit *4	
		Linearity	± 1 % F.S. *4	
	Temp. characteristic	± 2 % F.S. (compare with *4)		
	Switch output	Switch output	2 NPN : open collector 2 outputs Max. Load Current : 125 mA Max. Supply Voltage : 28 V DC Voltage Drop : ≤ 1.5 V	2 PNP : open collector 2 outputs Max. Load Current : 125 mA Max. Supply Voltage : 24 V DC Voltage Drop : ≤ 1.5 V
Response time		Flow	800 ms (50 ms, 80 ms, 120 ms, 200 ms, 400 ms, 1500 ms selectable)	
		Pressure	2.5 ms (25 ms, 100 ms, 250 ms, 500 ms, 1000 ms, 1500 ms selectable)	
Output mode		Flow	Hysteresis Mode, Window Comparator Mode, Accumulated Output, Accumulated Pulse Output	
		Pressure	One Point Set Mode, Hysteresis Mode, Window Comparator Mode	
Hysteresis		Adjustable		
Output short circuit protection	Yes			
Analog output	Voltage output	Voltage output range : 1 ~ 5 V *5 ; Output impedance : 1 KΩ		
	Current output	Current output range : 4 ~ 20 mA *5 ; Load impedance : ≤ 300 Ω		
	Response time	Pressure : ≤ 50 ms ; Flow : ≤ 100 ms		
External input	Non-voltage input, < 0.4 V, ≥ 30 ms			
Communication interface	RS-485 *6,7			
Power	Power supply voltage	12 ~ 24 V DC ± 10 % , Ripple (P-P) ≤ 10 %		
	Current consumption	≤ 50 mA		
Environment	Withstand Pressure	1000 kPa	1.5 MPa	
	Enclosure	IP40		
	Working Fluid Temp.	0 ~ 50 °C (No condensation or freezing)		
	Ambient Temp. Range	Operation : 0 ~ 50 °C ; Storage : -10 ~ 60 °C (No condensation or freezing)		
	Ambient Humidity Range	Operation / Storage : 35 ~ 85 % R.H. (No condensation)		
	Insulation Resistance	≥ 50 MΩ (500 V DC, between case and lead wire)	≥ 2 MΩ (500 V DC, between case and lead wire)	
	Withstand Voltage	1000 V AC in 1-min (between case and lead wire)	250 V AC in 1-min (between case and lead wire)	
	Vibration	Total amplitude 1.5 mm or 10 G, 10 Hz ~ 55 Hz ~ 10 Hz scan for 1 minute, 2 hours each direction of X, Y and Z		
	Shock	100 m/s ² (10 G), 3 times each in direction of X, Y and Z		
	EMC	IEC 61000-6-2, IEC 61000-6-4		
Lead wire	ø4 Oil-resistance cable (PVC) - 26 AWG (0.15 mm ²) - 6 cores			

*1. Condition: Inlet Pressure: MFP01: 300 kPa, MFP02: 600 kPa , Outlet Pressure: 1 atmospheric pressure, 25 °C

*2. Condition: Outlet Pressure: 1 atmospheric pressure, 25 °C

*3. MFP01: -90 ~ 800 kPa, MFP02: 0 ~ 1.0 MPa, Outlet Pressure: 1 atmospheric pressure, 25 °C

*4. Outlet flow rate = 0 L/min, 25 °C

*5. PWM output, corresponding to pressure sensor 0 ~ 1000 kPa

*6. This function only available for Output Specification -02 and -04.

*7. 4 data reading per time.

MFP01 / 02 Output circuit wiring graph

FLOW & PRESSURE SENSOR



Output circuit wiring graph

Model	MFP01/02-□-010	MFP01/02-□-011	MFP01/02-□-02
Connect diagram			
Output method	NPN output / Analog voltage output / External input	NPN output / Analog current output / External input	NPN output / RS-485 MODBUS mode
Model	MFP01/02-□-030	MFP01/02-□-031	MFP01/02-□-04
Connect diagram			
Output method	PNP output / Analog voltage output / External input	PNP output / Analog current output / External input	PNP output / RS-485 MODBUS mode

* Procedure to wiring RS485 products : To prevent product damage due to short circuit , MUST do RS485 line connection BEFORE power line connection.

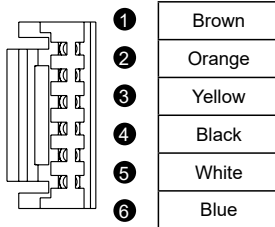

Pin no.	Line color	Content
1	Brown	Power supply (12 ~ 24 V DC)
2	Orange	Analog voltage output: 1 ~ 5 V
		Analog current output: 4 ~ 20 mA
3	Yellow	RS485 (B+)
		External input
4	Black	Output 1 (Max. load current: 125 mA)
5	White	Output 2 (Max. load current: 125 mA)
6	Blue	0 V (GND)

MFP01 / 02 Order example

FLOW & PRESSURE SENSOR



Order example

MFP02 – 501 – 010 – F7C

1

2

3

4

1

2

3

4

MODEL	FLOW RATE RANGE	OUTPUT METHOD	PORT SIZE
MFP01	005: 500 (ml/min) 010: 1000 (ml/min) 050: 5 (l/min) 100: 10 (l/min) 500: 50 (l/min)	010: 2 NPN output + 1 Analog output (1~5V) 011: 2 NPN output + 1 Analog output (4~20mA) 02 : 2 NPN output + RS485 030: 2 PNP output + 1 Analog output (1~5V) 031: 2 PNP output + 1 Analog output (4~20mA) 04 : 2 PNP output + RS485	R6: ø6 mm F1C: Rc1/8", with internal threads
	101: 100 (l/min) 201: 200 (l/min)		R8: ø8 mm F4C: Rc1/4", with internal threads
	501: 500 (l/min) 102: 1000 (l/min)		F7C: Rc1/2" F9C: G1/2"
MFP02	202: 2000 (l/min)		F10C: Rc3/4" F12C: G3/4"

Mounting accessories

MP – A27

1

2

1

2

MODEL	OPTION PARTS
MFP01	A26: Mounting bracket B4: Panel adapter C4: Panel adapter + Front protective lid
MFP02	A27: Mounting bracket, for 501, 102 A28: Mounting bracket, for 202

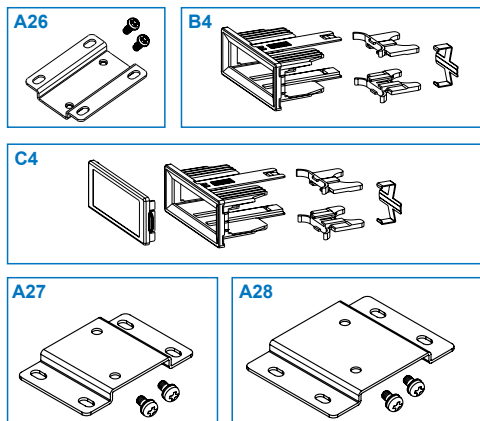

Name and functions of individual parts

Panel description

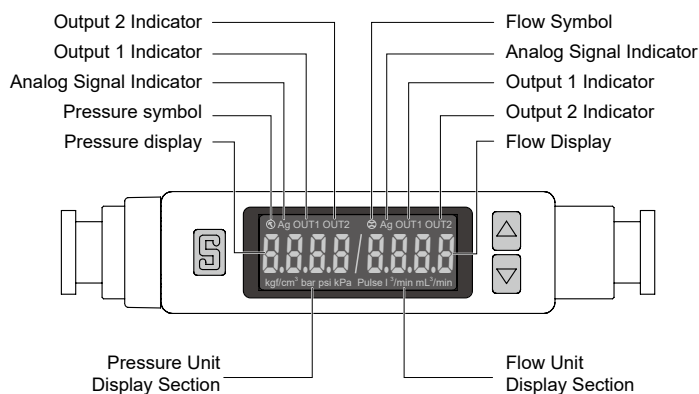

Body description

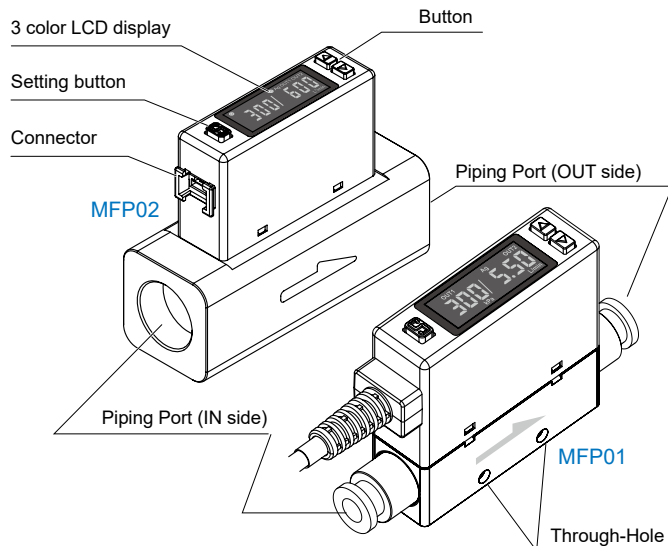

MFP01 Dimensions

FLOW & PRESSURE SENSOR



Mindman

Port size

R6 (ø6)

R8 (ø8)

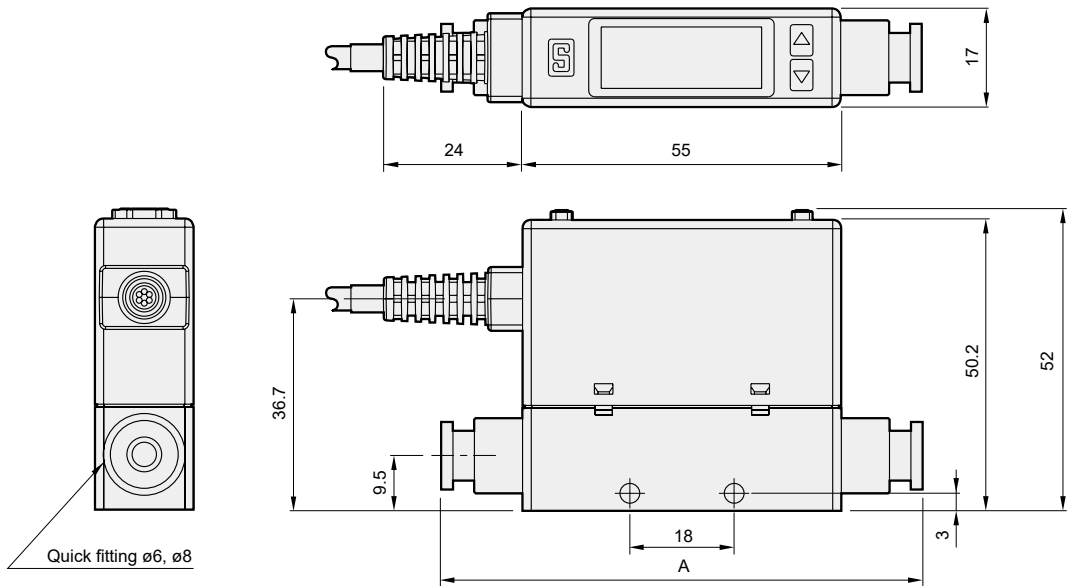

Code Tube I.D.	A (mm)
ø8	92.2
ø6	83

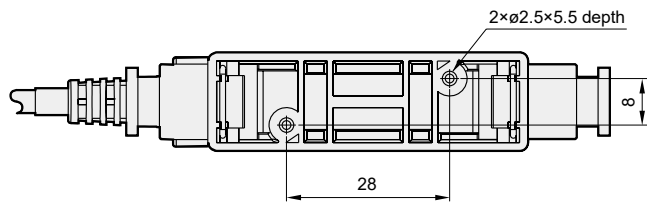

Port size

F1C (Rc1/8")

F4C (Rc1/4")

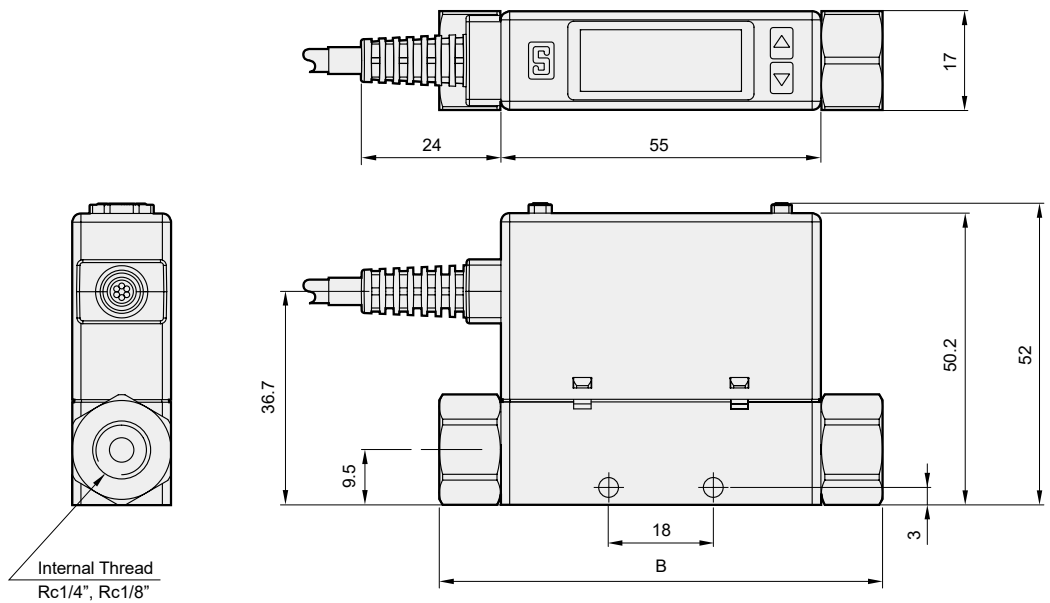

Code Thread	B (mm)
Rc1/8"	76.2
Rc1/4"	76.2

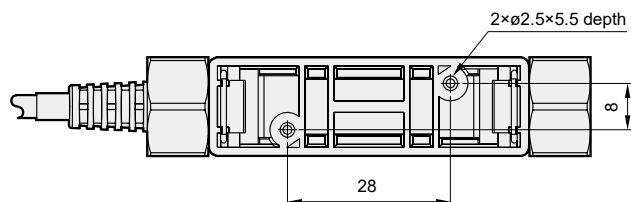

MFP01 Mounting accessories

FLOW & PRESSURE SENSOR



Mounting bracket

MP-A26

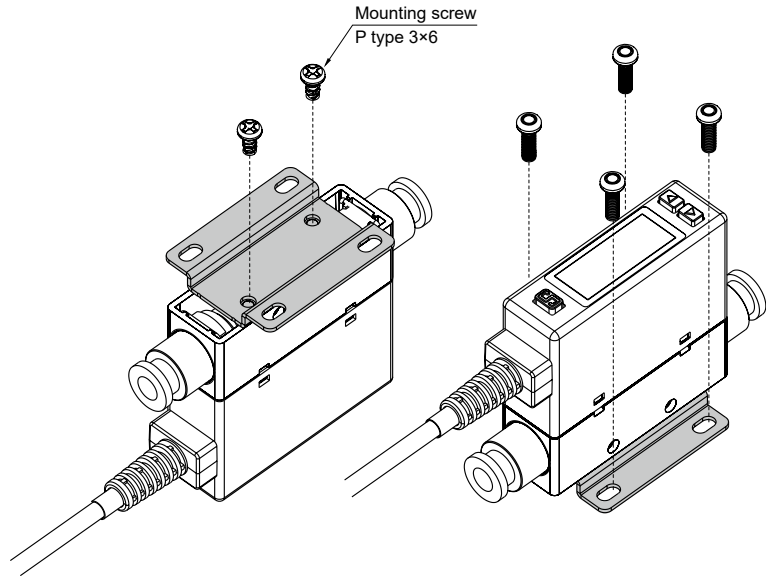
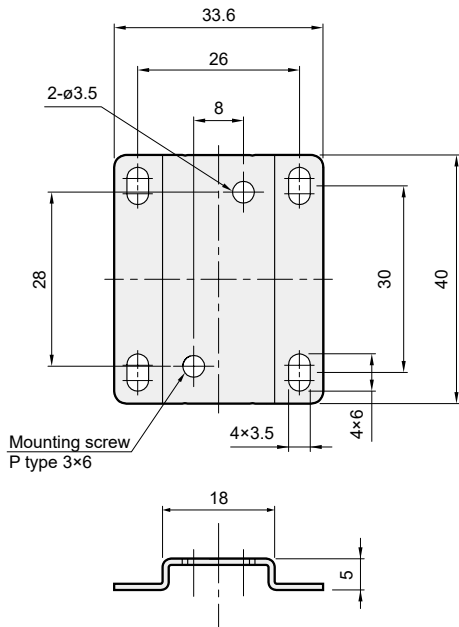

Panel type

Front protective lid + Panel adapter **MP-C4**

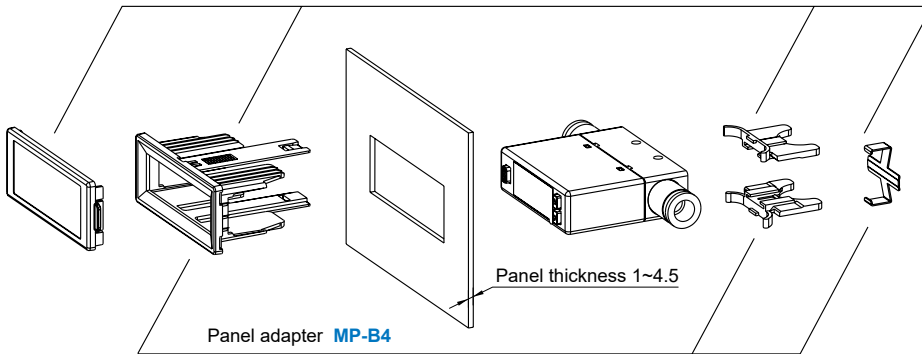

Panel cut dimensions

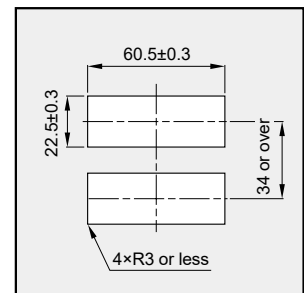

Front protective lid

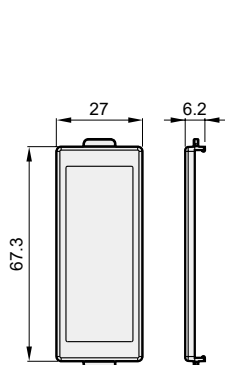

Panel adapter

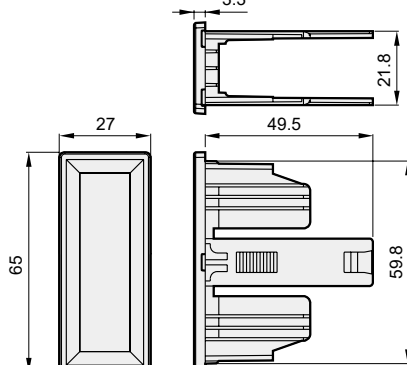

Panel adapter

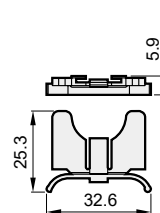

Panel adapter

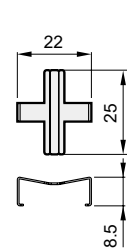

MFP02 Dimensions

FLOW & PRESSURE SENSOR



Dimensions

Port size
F7C (Rc1/2")
F9C (G1/2")

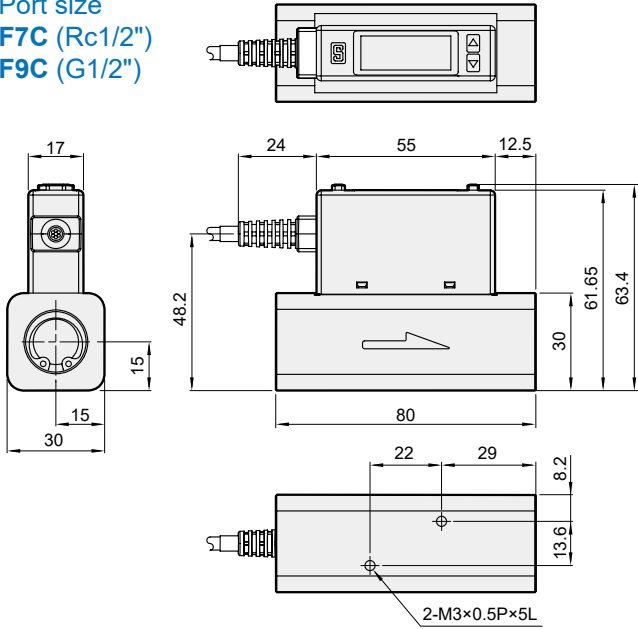

Port size
F10C (Rc3/4")
F12C (G3/4")

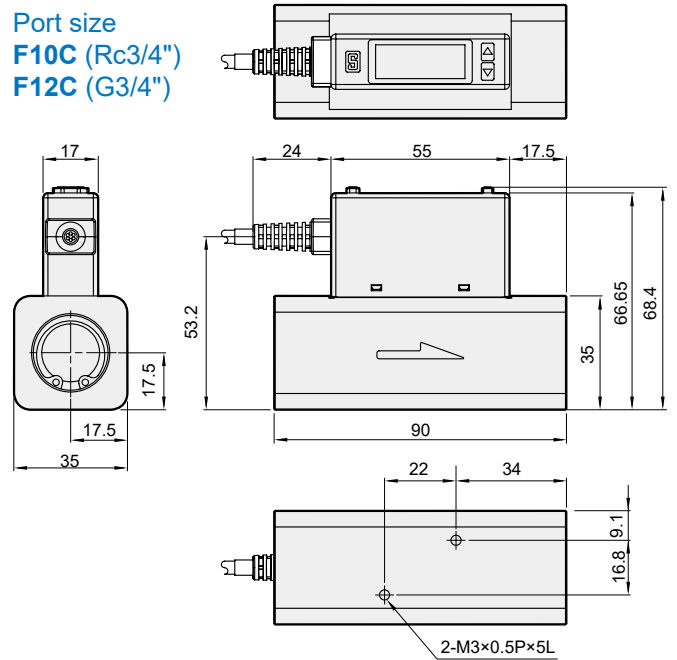

Mounting bracket

MP-A27

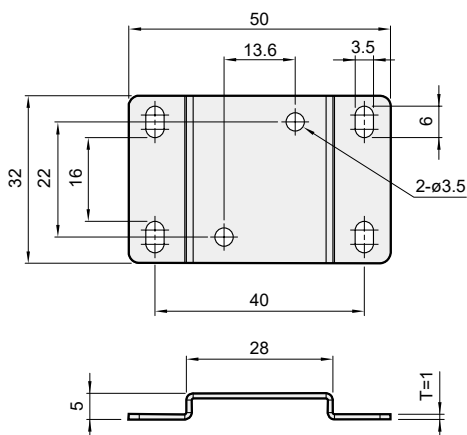
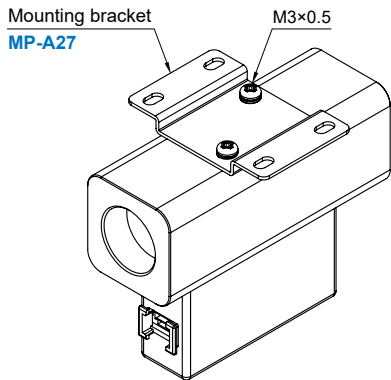

MP-A28

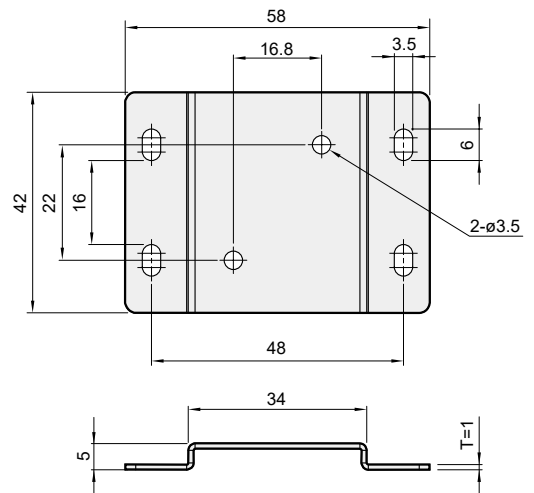
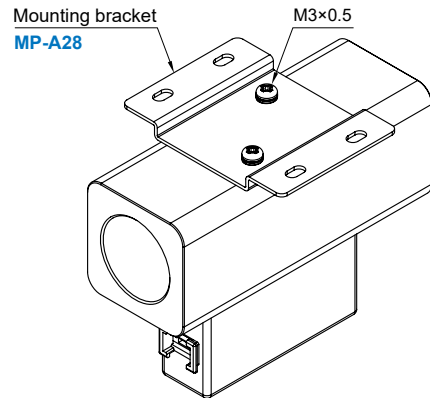

MFPS series

FLOW & PRESSURE SENSOR



User manual



Selection table

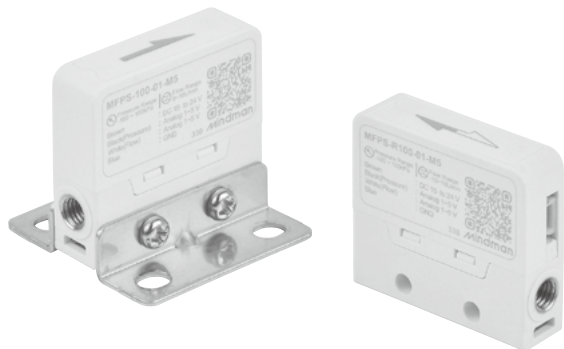

Feature

- Simultaneous monitoring of flow and pressure
- Approximate linear analog output of flow
- 3-color indicator
- 2 Analog outputs 1 ~ 5 V
- Response time ≤ 5 ms

Features highlight

2 in 1 design

- Pressure and flow rate simultaneous monitoring.

Flow sensor		Pressure sensor
Analog output 1~5 V		Analog output 1~5 V
Bidirectional	1~3~5V -F.S.~0~F.S. (L/min)	1~3~5V -100~0~100 kPa
Unidirection	1~5V 0~F.S. (L/min)	

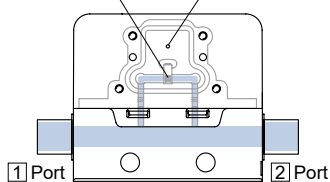

Approximate linear analog output

- Compared to existing flow sensors, it is better at monitoring flow rate for slight changes.

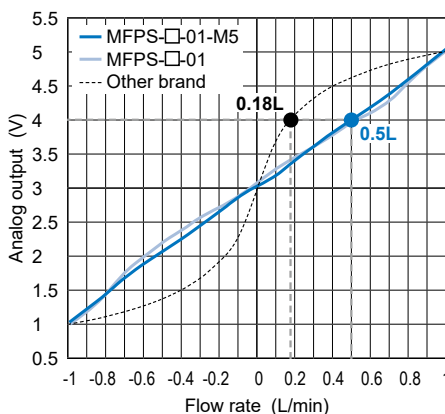

Equipped with pressure sensor

- Manage nozzle between pressure range -100 ~ 100 kPa.

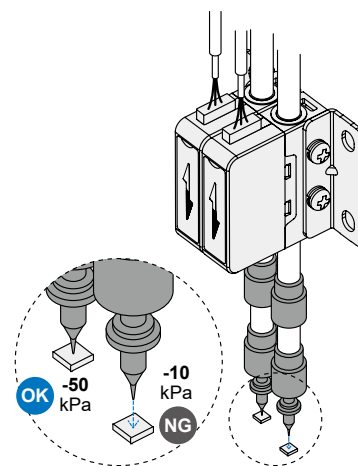

The design of 3-color indicator (signal) helps better monitor changes in flow and pressure

- Detect anomalies in time to reduce loss.

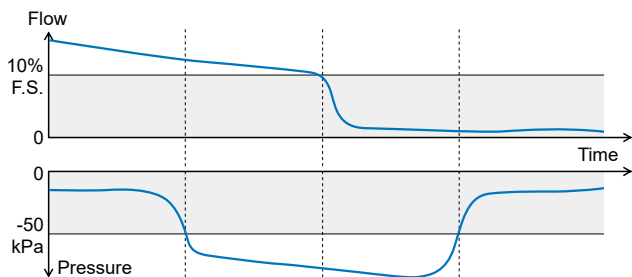

Vacuum Pressure : Suction

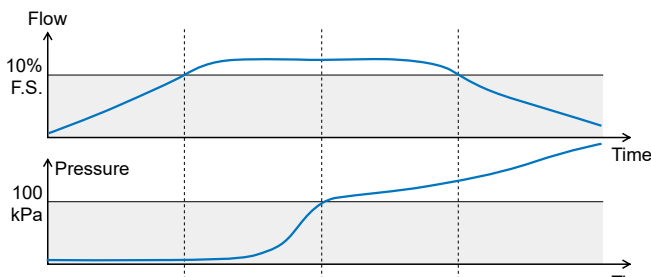
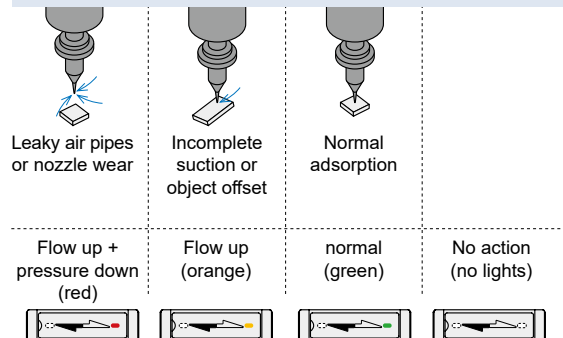

Positive Pressure : Release

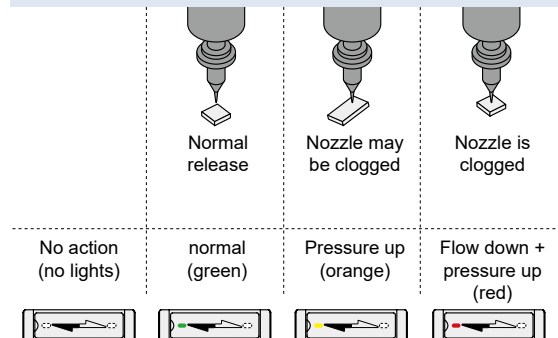

Model		003	005	010	050	100	R003	R005	R010	R050	R100	
Flow	Measured flow rate range	0 ~ 0.3 L/min	0 ~ 0.5 L/min	0 ~ 1 L/min	0 ~ 5 L/min	0 ~ 10 L/min	-0.3 ~ 0.3 L/min	-0.5 ~ 0.5 L/min	-1 ~ 1 L/min	-5 ~ 5 L/min	-10 ~ 10 L/min	
	Flow direction	Unidirection					Bidirectional					
Pressure	Rated pressure range	-100 ~ 100 kPa										
Withstand pressure		300 kPa										
Fluid		Dry air, N ₂ , Non-corrosive / Non-flammable gas										
Power supply voltage		15 ~ 24V DC ±10%, Ripple (P-P) ≤ 10%										
Current consumption		≤ 30mA										
Flow	Repeatability	≤ ± 2% F.S.										
	Linearity	Non-linearity *1										
	Temp. characteristic *2	≤ ± 0.6% F.S./°C					≤ ± 0.3% F.S./°C					
	Pressure characteristic *3	± 10% F.S.					± 5% F.S.					
Pressure	Repeatability	≤ ± 1% F.S.										
	Linearity	± 0.5% F.S.										
	Temp. characteristic *2	± 2% F.S.										
Response time	Flow	≤ 5ms (90% Response time)										
	Pressure	≤ 1ms										
Switch on indicator		Green/ orange/ red										
Analog Output	Flow	Voltage Output Range: 1~5V ±5% F.S. (±0.2V) (Non-linearity), Output Impedance: 1 KΩ										
	Pressure	Voltage Output Range: 1~5V ±1% F.S. (±0.04V) (Linearity), Output Impedance: 1 KΩ										
Environment	Enclosure	IP40										
	Working fluid temp.	0 ~ 50°C (No condensation or freezing)										
	Ambient temp. range	Operation : 0 ~ 50°C ; Storage : -10 ~ 60°C (No condensation or freezing)										
	Ambient humidity Range	Operation / Storage : 35 ~ 85% R.H. (No condensation)										
	Withstand voltage	1000V AC in 1-min (between case and lead wire)										
	Insulation resistance	≥ 50MΩ (500V DC, between case and lead wire)										
	Vibration	Total amplitude 1.5mm or 10G, 10 Hz - 55 Hz - 10 Hz scan for 1 minute, 2 hours each direction of X, Y and Z										
	Shock	100m/s ² (10G), 3 times each in direction of X, Y and Z										
Lead Wire		Ø2.9 PUR - 28 AWG (0.078 mm ²) - 4 cores										
Weight (with 3 meter lead wire)		Approx. 43 g (w/o Port) ; Approx. 47 g (M5 Port)										
Circuit wiring diagrams												

*1. Approximate linearity analog output (±10% F.S.) except 0 ~ 10 L and 10 ~ 10 L.

*2. Benchmark : 25°C (Temperature range : 0 ~ 50°C)

*3. Benchmark : 0 kPa (Pressure range : -90 ~ 200kPa)

Adsorption application table

Flow range (L/min)	Application nozzle size (mm)	Application industry
-0.3 ~ 0.3	≤ ø0.1	Quartz crystal oscillator, solder balls, micro LEDs
-0.5 ~ 0.5	ø0.2	Chip resistors, chip capacitors, optical components, mini LEDs
-1.0 ~ 1.0	ø0.3	
-5.0 ~ 5.0	Inverted pyramid wafer nozzle	Silicon wafer (bonded die), general parts
-10 ~ 10	Inverted pyramid wafer nozzle	

Order example

MFPS - 003 - 01 - M5

MODEL

FLOW RATE RANGE

OUTPUT

PORT SIZE

003: 0 ~ 0.3 L/min
005: 0 ~ 0.5 L/min
010: 0 ~ 1 L/min
050: 0 ~ 5 L/min
100: 0 ~ 10 L/min

01: 2 Analog output (1 ~ 5V)

Blank: None
M5: M5 female thread

R003: -0.3 ~ 0.3 L/min
R005: -0.5 ~ 0.5 L/min
R010: -1 ~ 1 L/min
R050: -5 ~ 5 L/min
R100: -10 ~ 10 L/min

Mounting accessories (Option)

MP - A29-1

MODEL

OPTION PARTS

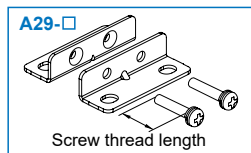

A29-1: fit with 1 sensor (Bracket + M3×0.5×15L screw)
A29-2: fit with 2 sensors (Bracket + M3×0.5×25L screw)
A29-3: fit with 3 sensors (Bracket + M3×0.5×35L screw)
A29-4: fit with 4 sensors (Bracket + M3×0.5×45L screw)
A29-5: fit with 5 sensors (Bracket + M3×0.5×55L screw)

Optional parts dimensions

MFPS*-01

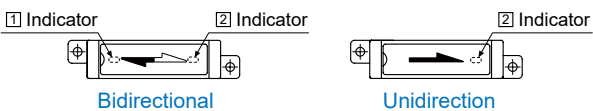
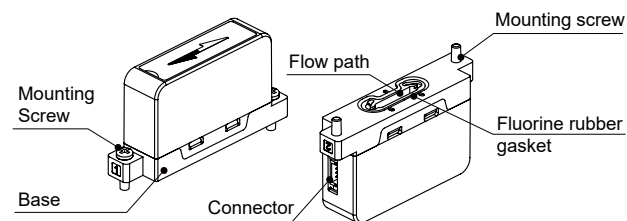

MFPS*-01-M5

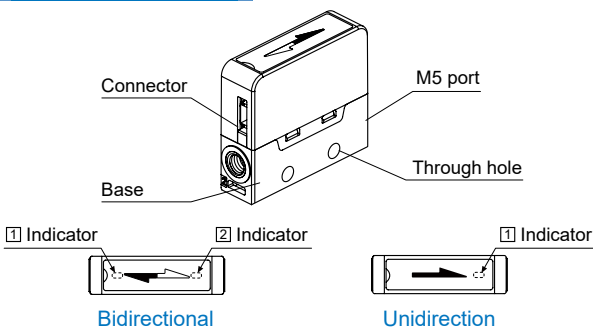

Wetted parts

MFPS*-01

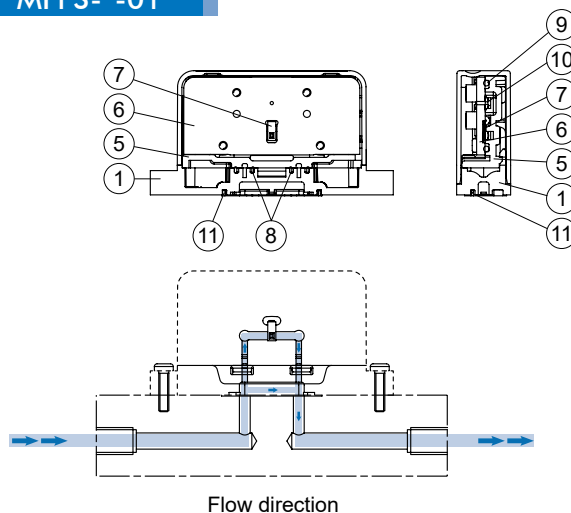

MFPS*-01-M5

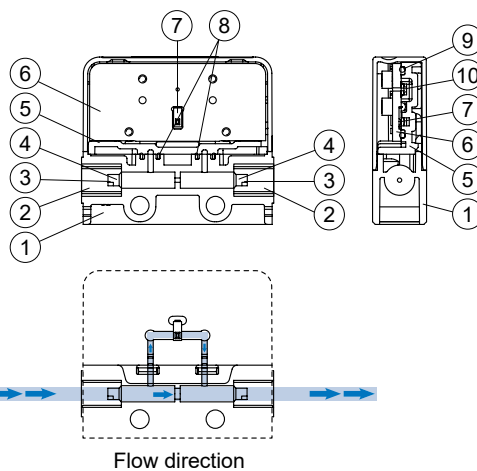

Material

No.	Description	Material
1	Base	PBT
2	Fitting for piping	SUS 303
3	Mesh holding screw	POM
4	Mesh	SUS 316
5	PCB-Holder	PBT
6	Sensor Board	GE4F
7	Sensor	Si
8	Gasket	Viton
9	Gasket	Viton
10	Sensor	Si
11	Gasket	Viton

Installation precautions

1. This product can be installed in any direction; top, bottom, left, or right.
2. MFPS-□-01 can be installed with 2 through holes (ø2).

Port thread	Tightening torque N.m
M2	0.2~0.3

3. When mounting, please use wrench on specified position as below.
Using on other parts of the product with a wrench may damage the product.
4. Please ensure the size of fittings are within the width of MFPS-□-01-M5 while connecting multiple sensors side by side.
5. Please be aware the tightening torque when mounting.
6. After installing, please take a leakage test to ensure the installation is appropriate.

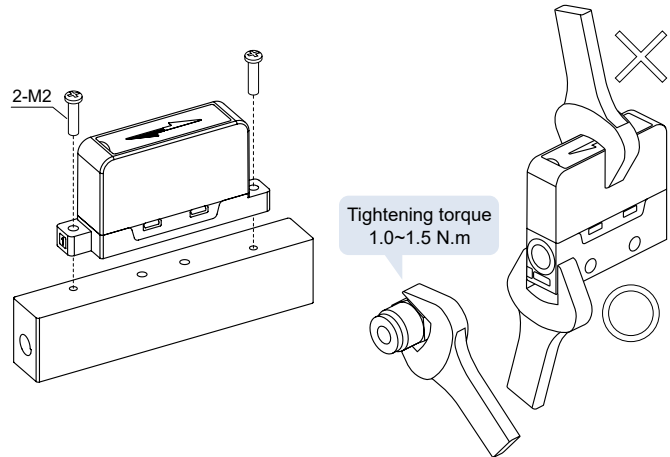

Dimensions

MFPS-* -01

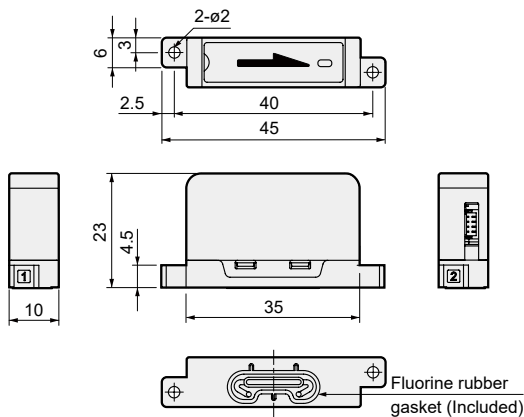

Installation

MFPS-* -01

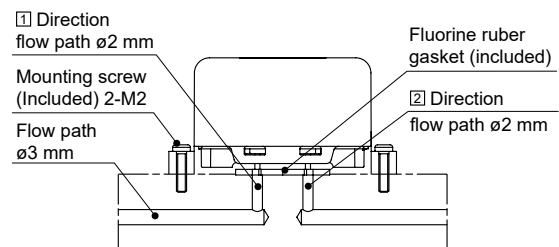
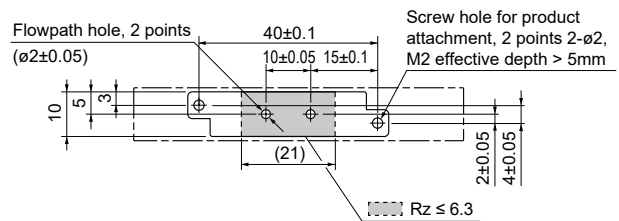

MFPS-* -01-M5

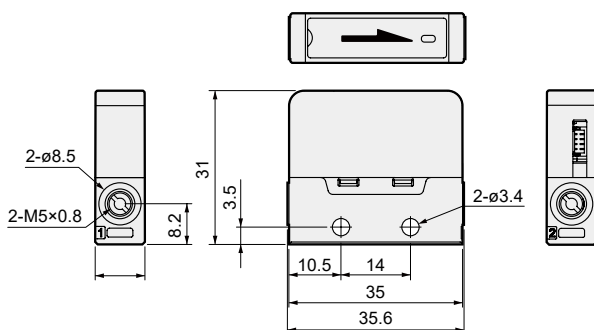

Mounting accessories

Bracket (Through hole) **MP-A29***

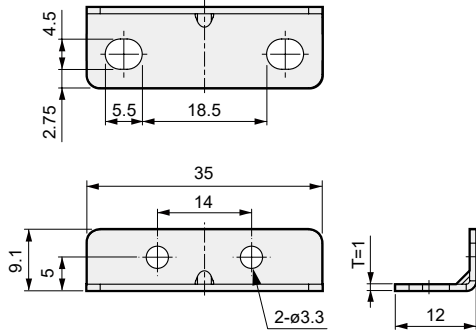

Bracket (Tapped hole)

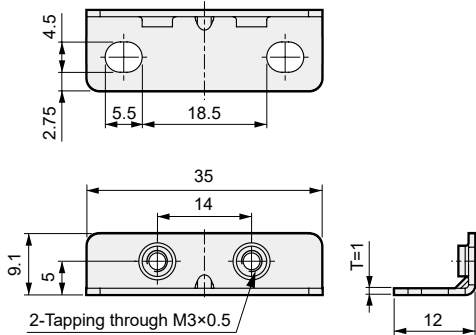

Installation dimension of bracket

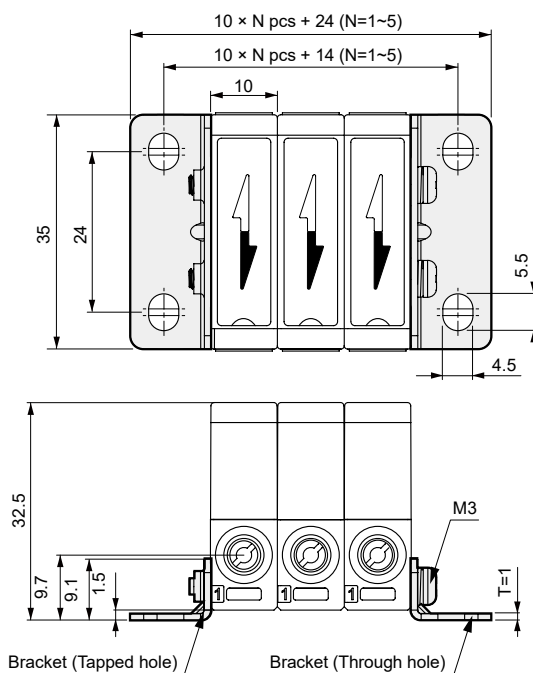

Mounting bracket

Horizontal mounting

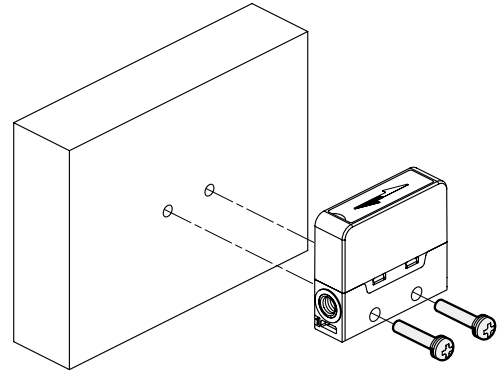

Bracket mounting

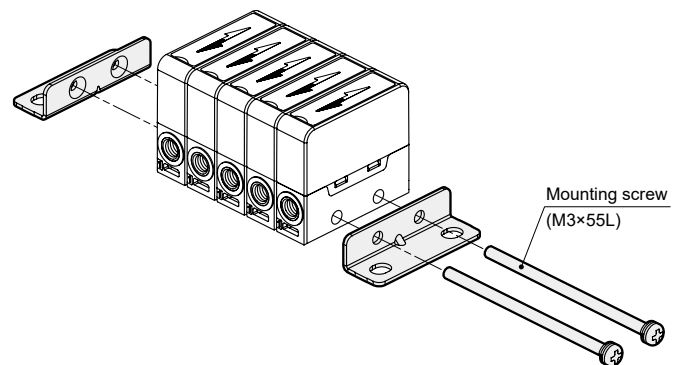
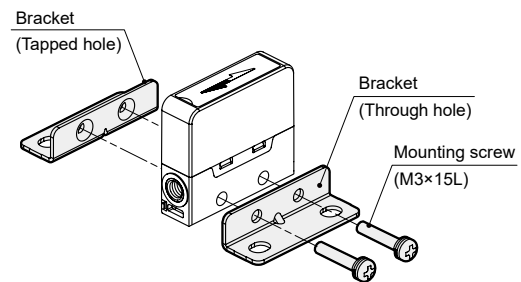
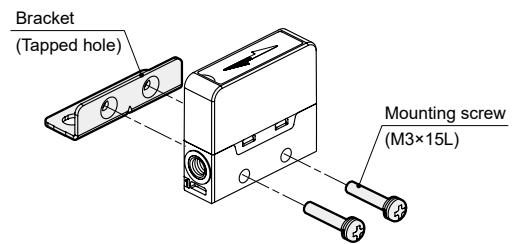

Port thread	Tightening torque N·m
M3	0.2 ~ 0.3



User manual



Selection table



Feature

- Response time ≤ 5 ms
- Slim size
- Light weight
- Confirmation of small object adsorption
- Leak detection
- Suitable for the semiconductor industry

Specifications

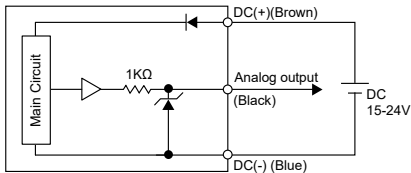
Model	003	005	010	050	100	R003	R005	R010	R050	R100	
Measured flow rate range	0 ~ 0.3 L/min	0 ~ 0.5 L/min	0 ~ 1 L/min	0 ~ 5 L/min	0 ~ 10 L/min	-0.3 ~ 0.3 L/min	-0.5 ~ 0.5 L/min	-1 ~ 1 L/min	-5 ~ 5 L/min	-10 ~ 10 L/min	
Flow direction	Unidirection					Bidirectional					
Rated pressure range	-100 ~ 200 kPa										
Withstand pressure	300 kPa										
Fluid	Dry air, N ₂ , Non-corrosive / Non-flammable gas										
Power supply voltage	15 ~ 24V DC $\pm 10\%$, Ripple (P-P) $\leq 10\%$										
Current consumption	≤ 20 mA										
Accuracy	Repeatability	$\leq \pm 2\%$ F.S.									
	Linearity	Non-linearity									
	Temp. characteristic *1	$\leq \pm 0.6\%$ F.S./°C					$\leq \pm 0.3\%$ F.S./°C				
	Pressure characteristic *2	$\pm 10\%$ F.S.					$\pm 5\%$ F.S.				
Response time	≤ 5 ms (90% Response time)										
Indicator	Green LED										
Analog output	Voltage output range: 1~5V $\pm 5\%$ F.S. (± 0.2 V) (Non-linearity), Output Impedance: 1 K Ω										
Environment	Enclosure	IP40									
	Working fluid temp.	0 ~ 50°C (No condensation or freezing)									
	Ambient temp. range	Operation : 0 ~ 50°C ; Storage : -10 ~ 60°C (No condensation or freezing)									
	Ambient humidity Range	Operation / Storage : 35 ~ 85% R.H. (No condensation)									
	Withstand voltage	1000V AC in 1-min (between case and lead wire)									
	Insulation resistance	≥ 50 M Ω (500V DC, between case and lead wire)									
	Vibration	Total amplitude 1.5mm or 10G, 10 Hz - 55 Hz - 10 Hz scan for 1 minute, 2 hours each direction of X, Y and Z									
Shock	100m/s ² (10G), 3 times each in direction of X, Y and Z										
Lead Wire	$\varnothing 2.6$ oil-resistance cable (PVC) - 26 AWG (0.15 mm ²) - 3 cores										
Weight	Product	Approx. 4 g (w/o Port) ; Approx. 9.6 g (M5 Port)									
	Lead wire (3M)	31.8 g									
Circuit wiring diagrams											

*1. Benchmark : 25°C (Temperature range : 0 ~ 50°C)

*2. Benchmark : 150 kPa (Pressure range : -100 ~ 200 kPa)

Order example

MFS – 003 – 01 – M5

MODEL	FLOW RATE RANGE	OUTPUT	PORT SIZE
	003: 0 ~ 0.3 L/min 005: 0 ~ 0.5 L/min 010: 0 ~ 1 L/min 050: 0 ~ 5 L/min 100: 0 ~ 10 L/min R003: -0.3 ~ 0.3 L/min R005: -0.5 ~ 0.5 L/min R010: -1 ~ 1 L/min R050: -5 ~ 5 L/min R100: -10 ~ 10 L/min	01: 1 Analog output (1 ~ 5V) M5: M5 female thread	Blank : None M5: M5 female thread

Mounting accessories (Option)

MP – A30-1

MODEL	OPTION PARTS
-------	--------------

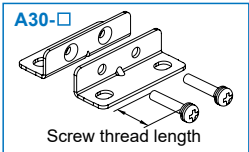

Screw thread length

A30-1: fit with 1 sensor (Bracket + M2×0.4×15L screws)
A30-2: fit with 2 sensors (Bracket + M2×0.4×25L screws)
A30-3: fit with 3 sensors (Bracket + M2×0.4×35L screws)
A30-4: fit with 4 sensors (Bracket + M2×0.4×45L screws)
A30-5: fit with 5 sensors (Bracket + M2×0.4×55L screws)

Optional parts dimensions

MFS-*-01

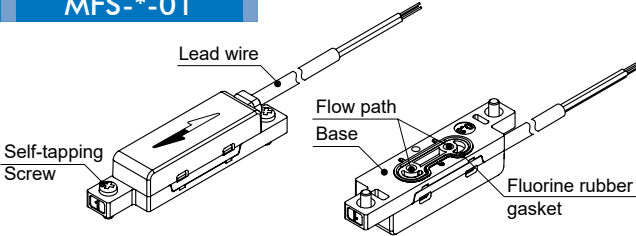

Lead wire
 Self-tapping Screw
 Flow path
 Base
 Fluorine rubber gasket

MFS-*-01-M5

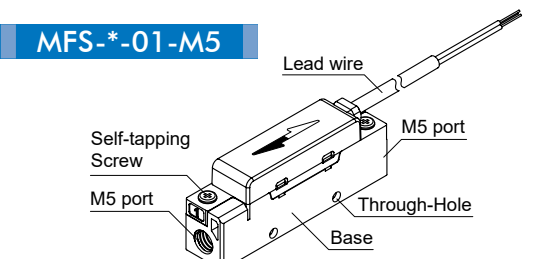

Lead wire
 Self-tapping Screw
 M5 port
 Through-Hole
 Base

* Do not set the self-tapping screws repeatedly.

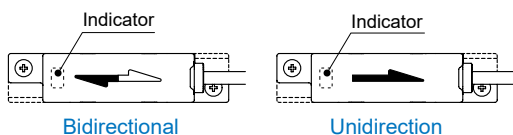

Wetted parts

MFS-*-01

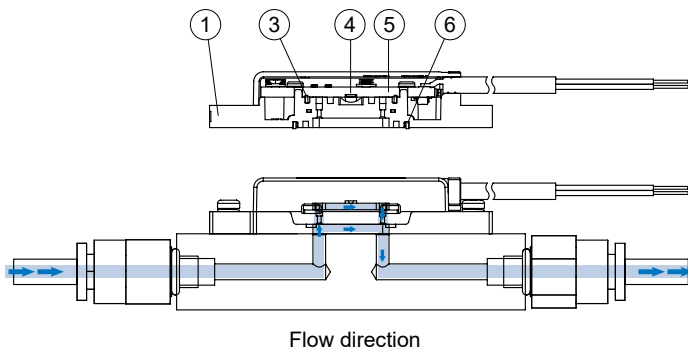

MFS-*-01-M5

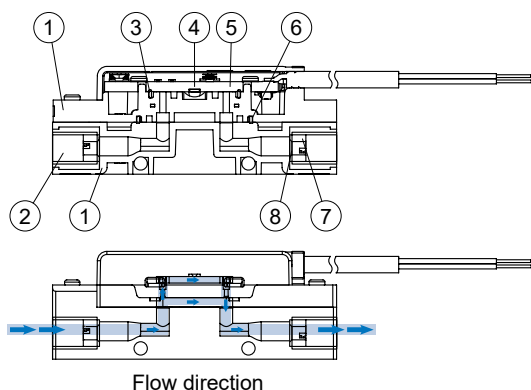

Material

No.	Description	Material
1	Base	PBT
2	Fitting for piping	SUS 303
3	Gasket	Viton
4	Sensor	Si
5	Sensor Board	GE4F
6	Gasket	Viton
7	Mesh holding screw	POM
8	Mesh	SUS 304

Installation precautions

1. This product can be installed in any direction; top, bottom, left, or right.
2. MFS-□-01 can be installed with 2 through holes (ø2).

Port thread	Tightening torque N.m
M2	0.2~0.3

3. When mounting, please use wrench on specified position as below.
Using on other parts of the product with a wrench may damage the product.
4. Please ensure the size of fittings are within the width of MFS-□-01-M5 while connecting multiple sensors side by side.
5. Please be aware the tightening torque when mounting.
6. After installing, please take a leakage test to ensure the installation is appropriate.

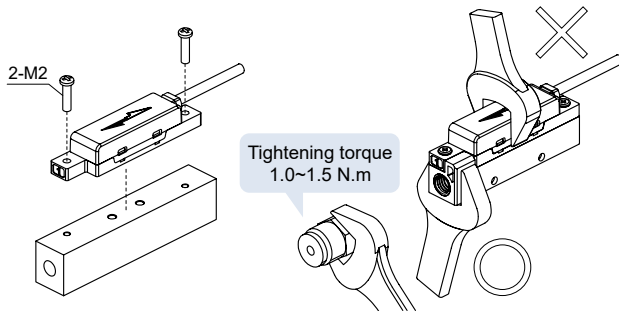

Installation

MFS-* -01

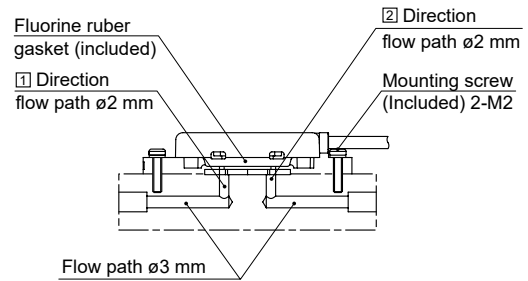
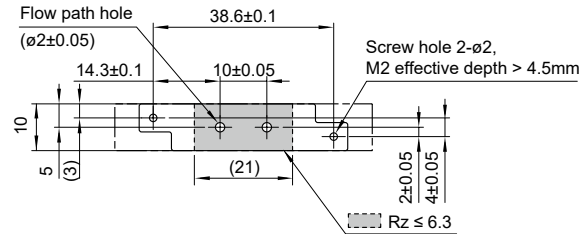

Dimensions

MFS-* -01

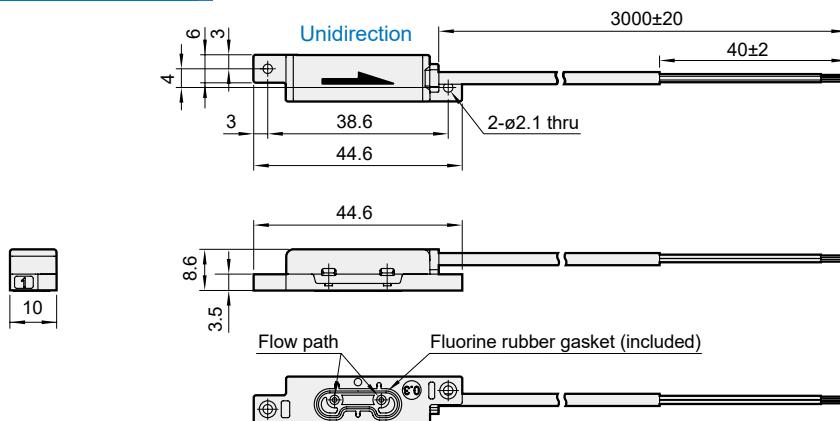

MFS-* -01-M5

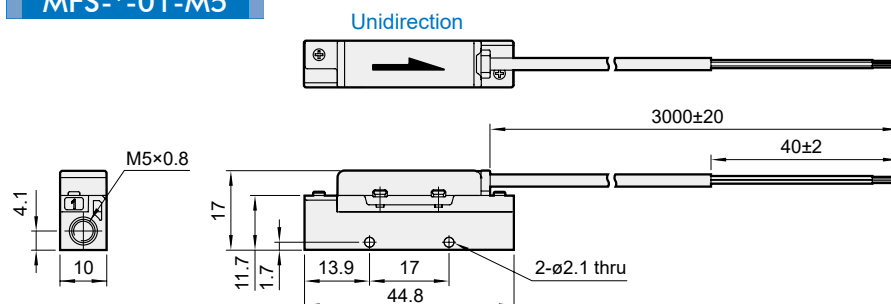

Mounting accessories

Bracket (Through hole)

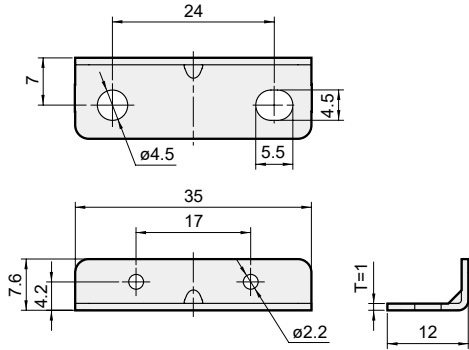

Bracket (Tapped hole)

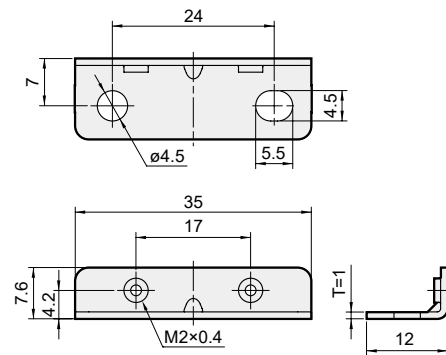

Installation dimension of bracket

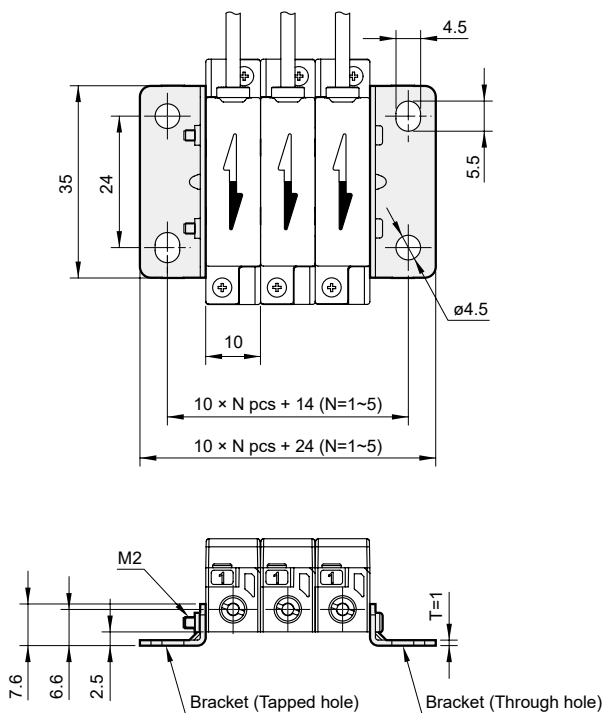

Mounting bracket

Horizontal mounting

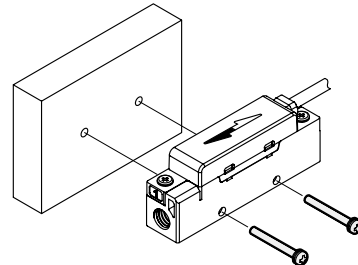

Bracket mounting

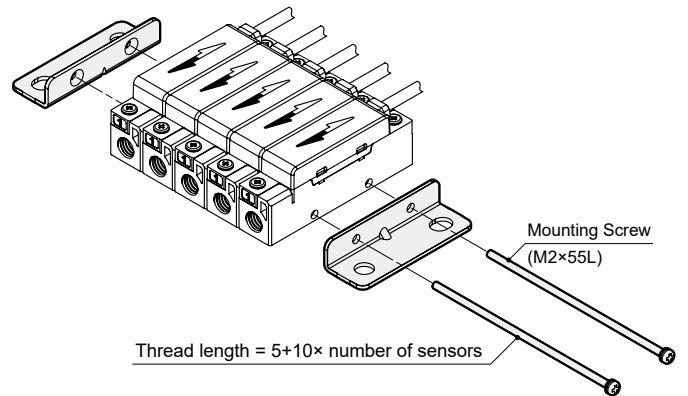
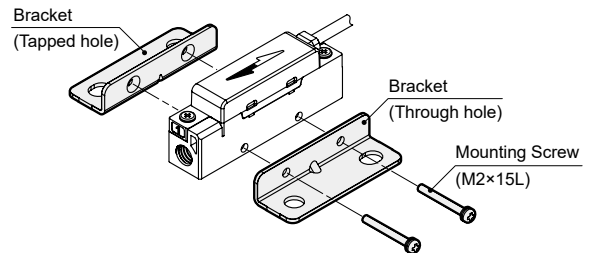
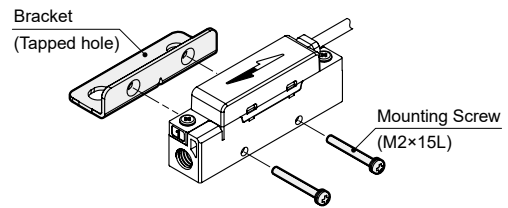

Port thread	Tightening torque N·m
M2	0.2 ~ 0.3

MPG-60 series

DIGITAL PRESSURE GAUGE



User manual



Selection table



Features

- 6 user programmable pressure units (kPa, MPa, kgf/cm², psi, bar, mmHg) available.
- Battery powered.
- Easy / fast read out with digital display.
- Power saving mode.
- Back light option.
- IP65 enclosure, dust and splash-proof.

Specification

Model	Vacuum		Positive	
	MPG-60V	MPG-60V-L	MPG-60P	MPG-60P-L
Rate / display pressure range	0 ~ -101 kPa / 10 ~ -101 kPa		0 ~ 1 MPa / -0.1 ~ 1 MPa	
Proof pressure	300 kPa		1.5 MPa	
Fluid	Filtered air, Non-corrosive gases, incombustible gases			
Set pressure resolution	kPa / MPa		1 / -	
	kgf/cm ² / bar		- / 0.01	
	psi		0.1	
	mmHg		1	
Battery / Battery replaceable	CR 2032 lithium / Yes			
Battery life	3 years (5 times/day)	1 years (5 times/day)	3 years (5 times/day)	1 year (5 times/day)
Low-power indicator	Yes			
Back light	No	Yes	No	Yes
Turn-on interval	Display turn off after 60 sec.			
Sampling rate	2 Hz (2 times/sec.)			
Programmable pressure unit	psi, bar, mmHg, kPa user selectable		psi, bar, kgf/cm ² , MPa user selectable	
Repeatability	±1% F.S. ±1digit		±0.2% F.S. ±1digit	
LCD display	3 ½ digital, 7 segment LCD display (Black)			
Indicator accuracy	±2% F.S. ±1 digit (Ambient temperature: 25 ±3 °C)			
Environment	Enclosure: IP65 (Air tube must be installed to maintain IP65)			
	Ambient temp. range: Operation: 0 ~ 50°C, storage: -10 ~ 60°C (No condensation or freezing)			
	Ambient humidity range: Operation/Storage: 35 ~ 85% RH (No condensation)			
	Vibration: Total amplitude 1.5mm or 10G, 10Hz-55Hz-10Hz scan for 1 minute, two hours each direction of X, Y and Z			
Shock: 100m/s ² (10G), 3 times each in direction of X, Y and Z				
Temperature characteristic	±2% F.S. of detected pressure (25°C) at temp. Range of 0~50°C			
Weight	Approx. 40 g			

Order example

MPG - 60 P - L - F1

MODEL

PRESSURE RANGE
V: Vacuum
P: Positive

BACK LIGHT
Blank: Back light unavailable
L: Back light available

PRESSURE PORT
F1: R1/8", M5
F2: NPT1/8", #10-32 UNF
F3: G1/8", M5
F4: R1/4", M5
F5: NPT1/4", #10-32 UNF
F6: G1/4", M5

Mounting accessories (Option)

MP - A5

MODEL

OPTION PARTS
A5: Mounting bracket
A6: Mounting bracket
B2: Panel adapter
C2: Panel adapter + Front protective lid

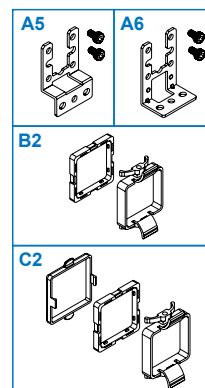

MPG-60 Dimensions

DIGITAL PRESSURE GAUGE



Dimensions

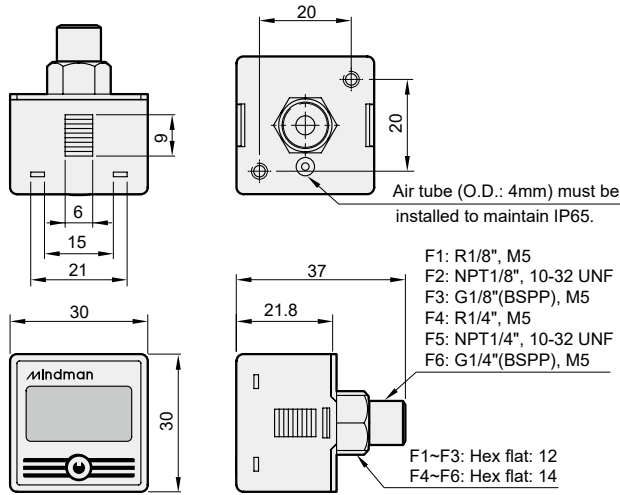

Panel instructions

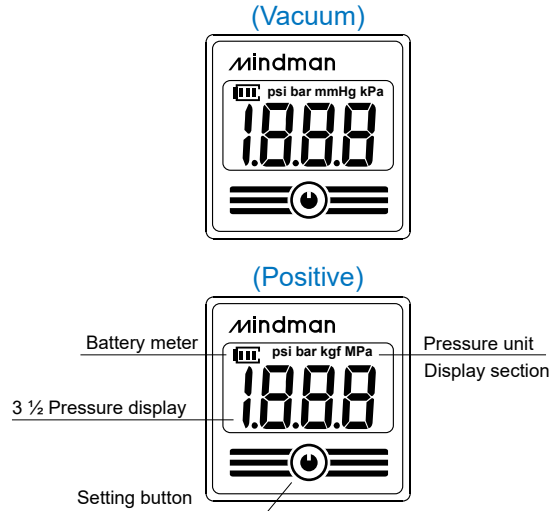

Mounting accessories

Mounting bracket

MP-A5

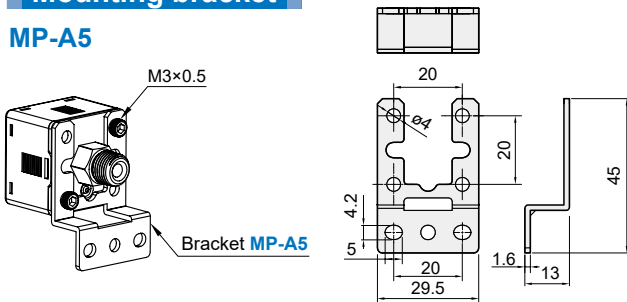

MP-A6

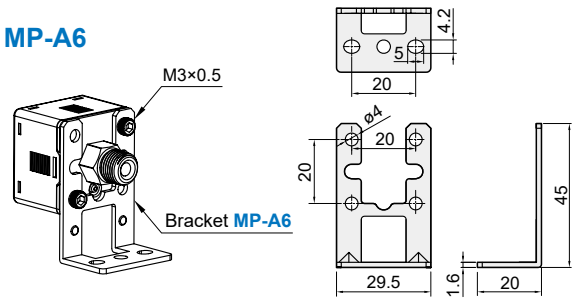

Panel type

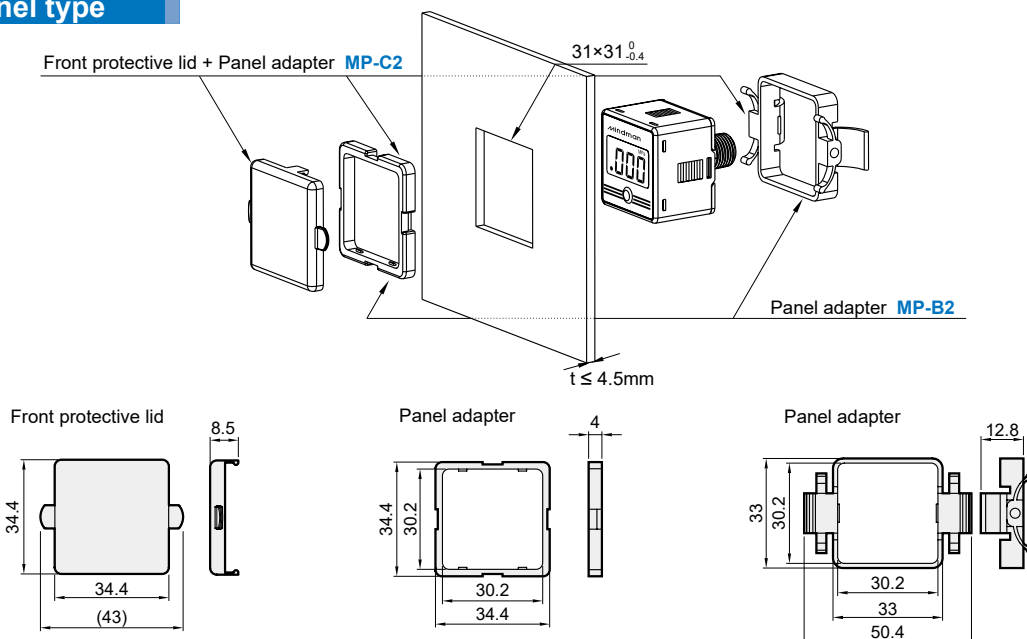



Selection table

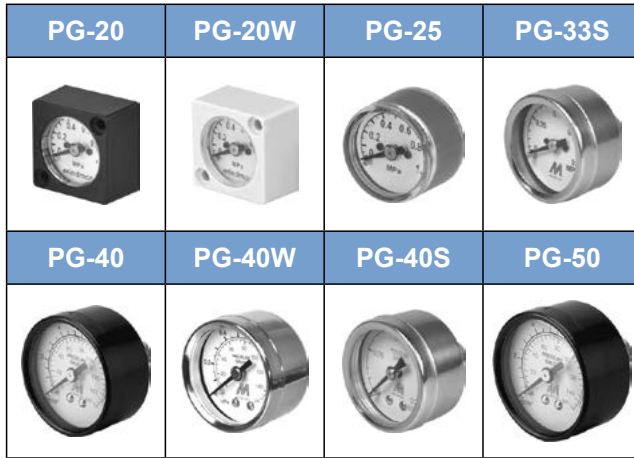

Specification

Model	PG-20	PG-25	PG-33	PG-40	PG-50
Bore No.	—	—	6A	6A	8A
Port size	—	1/16	1/8	1/8	1/4
Medium	Air				
Operating pressure range	By order specifications				
Proof pressure	The max. scale of gauge times 1.2				
Precision	±4% F.S.		ASME B class		
Ambient temperature	-5~+60°C (No freezing)				
Weight	11 g	17 g	34 g	54 g	108 g

* Please consult us if out of specification.

Order example

PG - 40 S - 1K - NPT

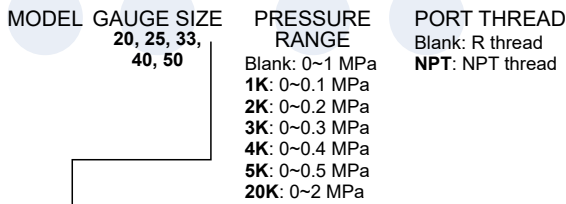

CASE MATERIAL

Code Model	W	S	Note
PG-20	○	○	W(White)
PG-25			
PG-33		○	
PG-40	○	○	W(Electroplating)
PG-50	○		

* Blank: Standard type (Black)
PG-25 standard type (Gray)
* S: Stainless steel

Code Model	1K	2K	3K	4K	5K	20K
PG-20	○	×	×	×	×	×
PG-20W	○	×	×	×	×	×
PG-25	○	×	×	×	×	×
PG-33S	○	×	○	×	×	×
PG-40	○	○	○	○	○	○
PG-40W	○	○	○	○	○	○
PG-40S	○	×	○	×	×	×
PG-50	○	×	×	×	×	○

PG-20

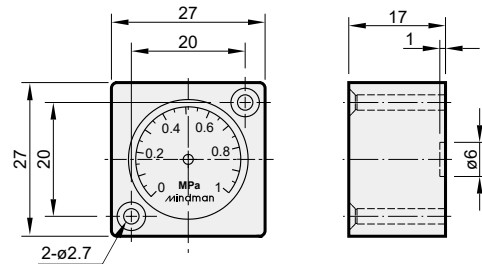

PG-25

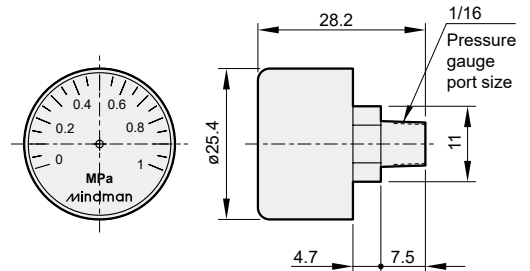

PG-33S

*Only for SUS case.

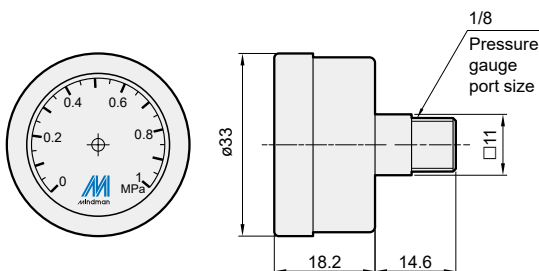

PG-40 / 50

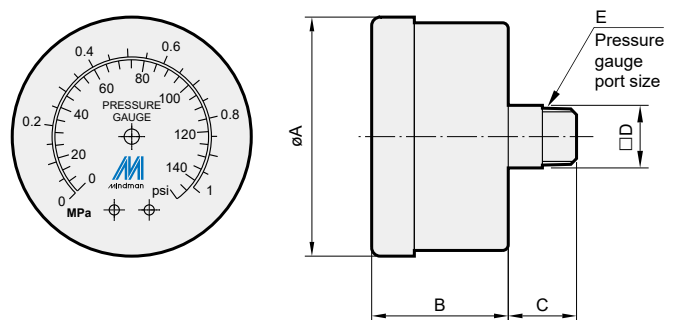

Code Model	A	B	C	D	E
PG-40	42	25	15	11	1/8
PG-50	53	26.5	22.5	14	1/4



Selection table



Specification

Model	PGV-40S
Bore No.	6A
Port size	1/8
Medium	Air
Operating pressure range	-100~0 kPa (*)
Precision	ASME B class
Ambient temperature	-5~+60°C (No freezing)
Weight	50 g

* Do not use for positive pressure, otherwise it will cause damage to pressure gauge.

Order example

PGV — 40 S — NPT

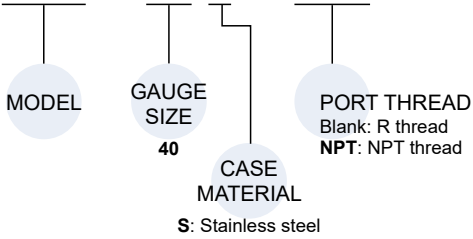

Dimensions

