

# CLAMP CYLINDER

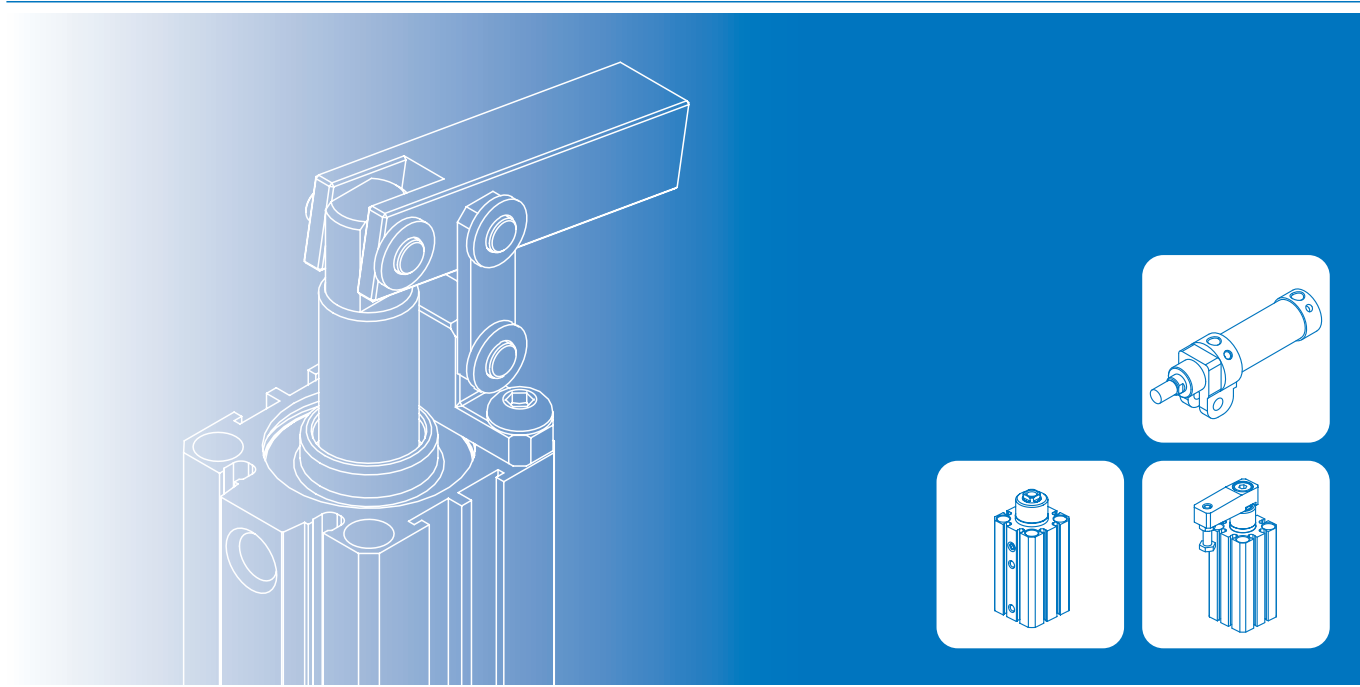

<b>MCKC</b>	ø12~ø63 .....	2-2
<b>MCKA</b>	ø40 .....	2-7
<b>MCKB</b>	ø25~ø63.....	2-10



Moment of inertia



Technical data



Caution for safety  
(Read before installing)

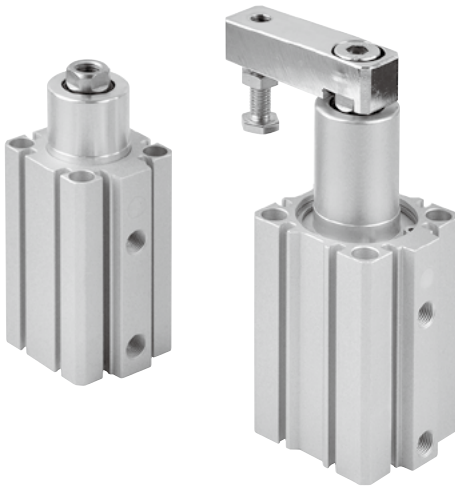

### Order example

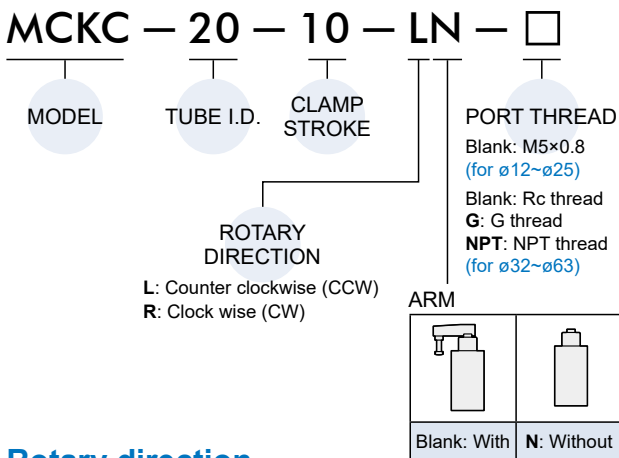

### Rotary direction

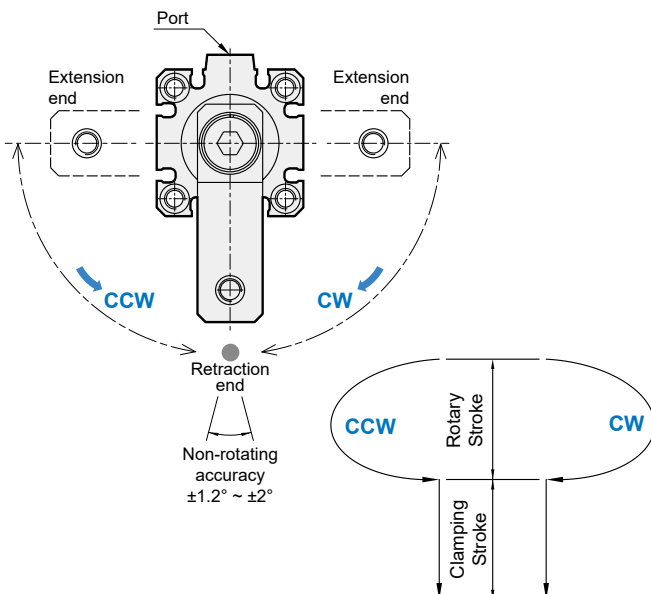

### Features

- Ultra compact, light weight and space saving cylinder.
- Ideal for use in machinery where space is limited and incorporating sensor groove which enables flush fitting of sensors.
- The sensor can freely mounted the four sides.
- Magnetic as standard.

### Specification

Model	MCKC							
Acting type	Double acting							
Tube I.D. (mm)	12	16	20	25	32	40	50	63
Port size	M5×0.8				Rc1/8		Rc1/4	
Rotary angle (Extension end)	90°±10°							
Rotary direction	CCW (L), CW (R)							
Rotary stroke (mm)	7.5		9.5		15		19	
Clamp stroke (mm)	10, 20		10, 20, 30, 50 (50 only for ø50, ø63)					
Medium	Air							
Operating pressure range	0.1~1 MPa							0.1~0.6
Ambient temperature	-5°C~+60°C (No freezing)							
Available speed range (*1)	50~200 mm/sec							
Non-rotating accuracy (*2)	±2°	±1.3°	±1.2°					
Lubrication	Not required							
Sensor switch (*3)	RDE	●	●	-	-	-	-	-
	RCE,RCE1	-	-	●	●	●	●	●
	RDEP	-	-	-	●	-	●	●

\*1. Keep the operating speed between 50~200mm/s with a speed controller.

Please refer to moment of inertia.

Adjust the speed gradually from state to prevent inner parts being damaged.

\*2. Arm during clamping (Clamp part).

\*3. RCE/RDE , RCE1 , RDEP specifications.

### Clamping arm mounting methods

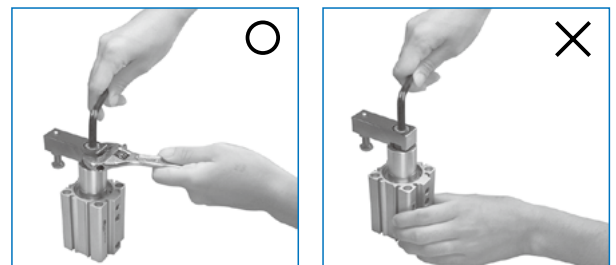

### Clamping arm tightening torque

Tube I.D. (mm)	Tightening torque (kgf·cm)
12	5.1 ~ 7.1
16	28.5 ~ 35.7
20, 25	117.2 ~ 142.7
32, 40	244.6 ~ 305.8
50, 63	764.5 ~ 917.4

### Moment of inertia

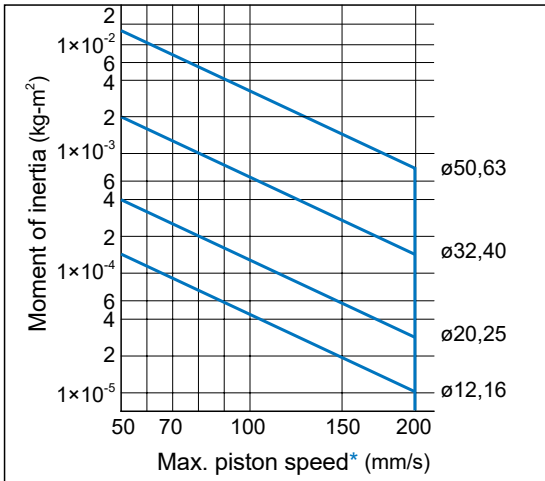

\* Max. piston speed is equivalent to approximately 1.6x the average piston speed. (Rough indication)

### Installation of sensor switch

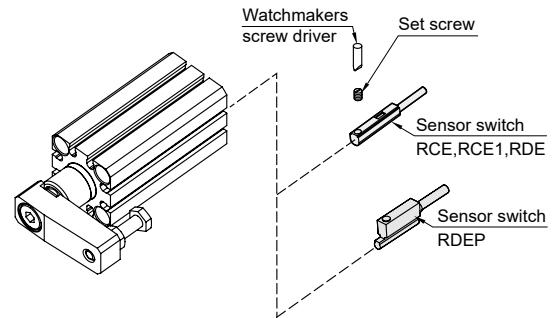

### Allowable bending moment

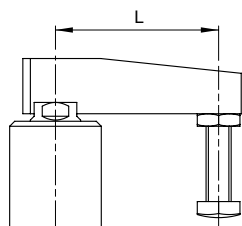
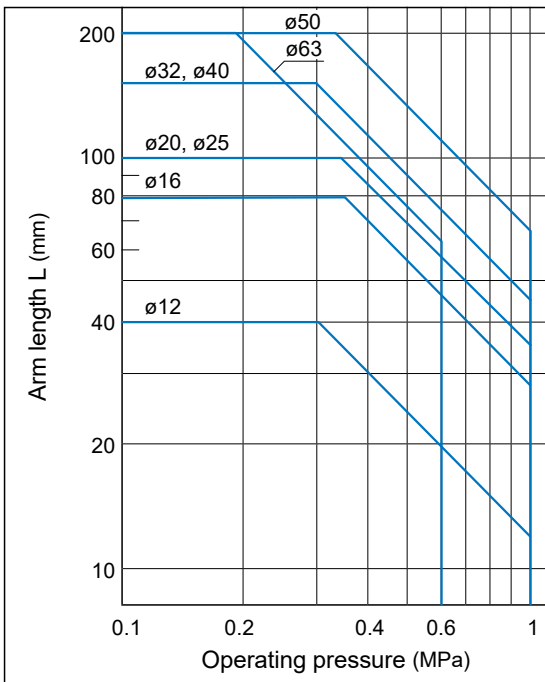

**CAUTION**

Do not use the cylinder under the following environments

- Areas that contain splashing cutting oil.
- Areas that contain foreign objects such as cutting chips or heavy-dust.
- Areas that environment temperature exceeds the operating range.
- Areas that expose to direct sunlight.
- Areas that contain corrosion risk.

A cylinder could malfunction or the non-rotating accuracy could be reduced if a rotational force is applied to the piston rod. Therefore, check the particular examples below before operating the cylinder.

- 1 Make sure to mount the cylinder vertically to the ground. (Fig.1)
- 2 Do not apply external rotary force on the piston rod. (Fig.2)
- 3 Make sure that the clamping surface of the workpiece is perpendicular to the axial line of cylinder. (Fig.3)
- 4 Clamping the workpiece in the clamping stroke of cylinder only. Do not clamp the workpiece in the rotary stroke. (Fig.4)
- 5 Make sure that the workpiece is not moved by external force while clamping. (Fig.5)

- 1 Do not mount the cylinder horizontally.

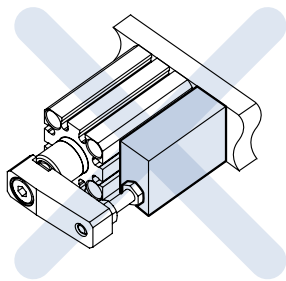

Fig.1

- 2 Do not apply external rotary force on the piston rod.

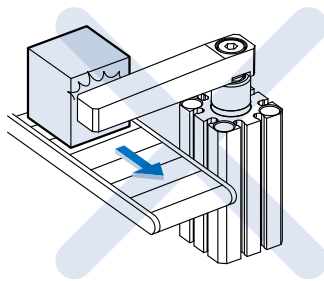

Fig.2

- 3 Do not clamp on a slope.

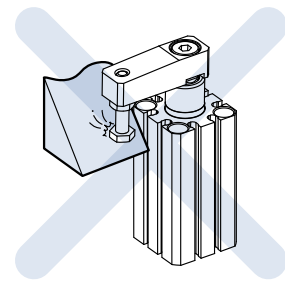

Fig.3

- 4 Do not clamp the workpiece in the rotary stroke.

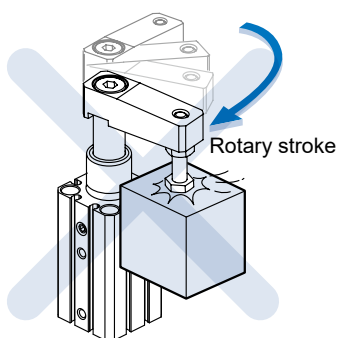

Fig.4

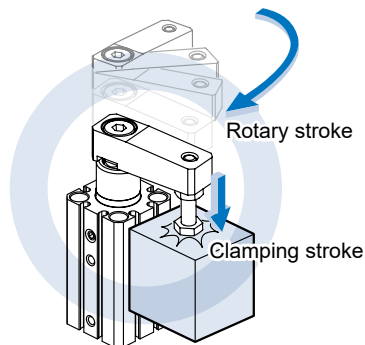

Fig.4

- 5 Make sure that the workpiece have no external force applied besides the cylinder while clamping.

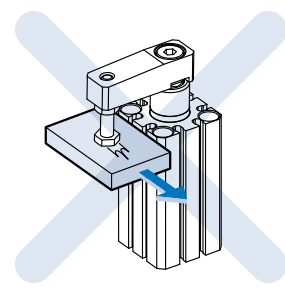
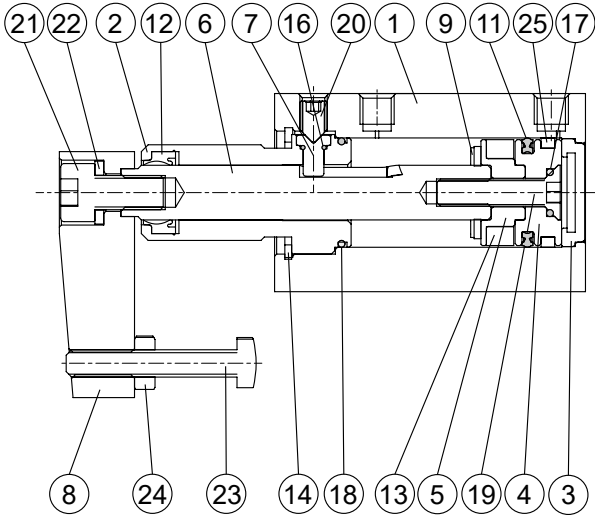
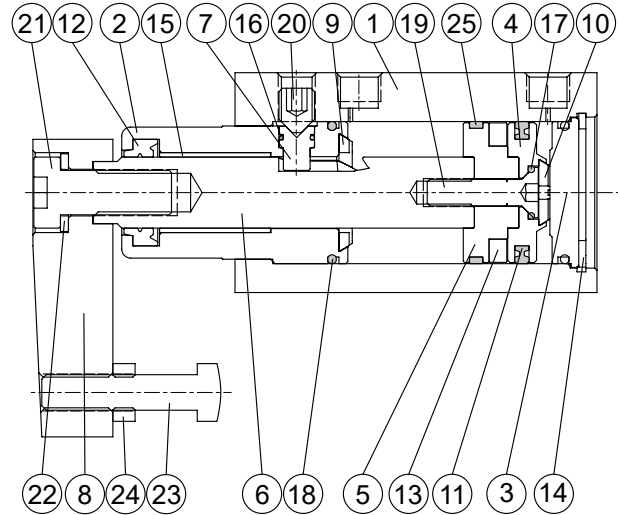

Fig.5

ø12, ø16, ø40, ø50, ø63



ø20, ø25, ø32



### Material

No.	Part name	Material	Note
1	Body	Aluminum alloy	
2	Rod cover	Aluminum alloy	
3	End cover	Aluminum alloy	
4	Piston	Aluminum alloy	
5	Piston for magnet ring	Aluminum alloy	
6	Piston rod	SCM	
7	Guide pin	SCM	
8	Arm	Carbon steel	
9	Rod cushion	NBR	
10	End cushion	NBR	For ø20~ø63
11	Piston packing	NBR	
12	Rod packing	NBR	
13	Magnet ring	Magnet material	

No.	Part name	Material	Note
14	Snap ring	Carbon steel	*1
15	Bush	Copper	For ø32~ø63
16	O-ring	NBR	
17	O-ring	NBR	
18	O-ring	NBR	
19	Bolt	Stainless steel	*2
20	Set screw	SCM	
21	Bolt	SCM	
22	Spring washer	Spring steel	
23	Bolt	SCM	
24	Nut	Carbon steel	
25	Wear ring	Resin	

\*1. ø20~ø32: Stainless steel  
\*2. ø32~ø63: Carbon steel

### Theoretical force

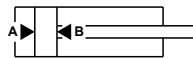

Tube I.D. (mm)	Piston rod (mm)	Operating direction	Piston area (mm <sup>2</sup> )	Operating pressure (MPa)								
				0.1	0.2	0.3	0.4	0.5	0.6	0.7	0.8	0.9
12	6	A	113	11.3	22.6	33.9	45.2	56.5	67.8	79.1	90.4	101.7
		B	85	8.5	17.0	25.5	34.0	42.5	51.0	59.5	68.0	76.5
16	8	A	201	20.1	40.2	60.3	80.4	100.5	120.6	140.7	160.8	181.0
		B	151	15.1	30.2	45.2	60.3	75.4	90.5	105.6	120.6	135.7
20	12	A	314	31.4	62.8	94.2	125.7	157.1	188.5	219.9	251.3	282.7
		B	201	20.1	40.2	60.3	80.4	100.5	120.6	140.7	160.8	181.0
25	12	A	491	49.1	98.2	147.3	196.4	245.4	294.5	343.6	392.7	441.8
		B	378	37.8	75.6	113.3	151.1	188.9	226.7	264.4	302.2	340.0
32	16	A	804	80.4	160.8	241.3	321.7	402.1	482.5	563.0	643.4	723.8
		B	603	60.3	120.6	181.0	241.3	301.6	361.9	422.2	482.5	542.9
40	16	A	1257	125.7	251.4	377.1	502.8	628.5	754.2	879.9	1005.6	1131.3
		B	1056	105.6	211.2	316.8	422.4	528.0	633.6	739.2	844.8	950.4
50	20	A	1964	196.3	392.5	588.9	785.2	981.6	1177.9	1374.2	1570.6	1766.9
		B	1649	164.9	329.7	494.7	659.6	824.5	989.5	1154.4	1319.3	1484.2
63	20	A	3117	311.7	623.4	935.1	1247.2	1559.3	1871.4	2183.5	2495.6	2807.7
		B	2803	280.3	560.6	840.9	1121.2	1401.5	1681.8	1962.1	2242.4	2522.7

Unit: N

### Cylinder weight

Unit: g

Model	Basic weight MCKC	Basic weight MCKC-N	Stroke 10 mm MCKC
Tube I.D.			
ø12	66	52	16
ø16	100	66	23
ø20	266	176	38
ø25	319	229	46
ø32	573	382	69
ø40	652	461	74
ø50	1170	820	109
ø63	1455	1105	143

## PNEUMATIC - SWING CLAMP CYLINDER

$\phi 12, \phi 16$

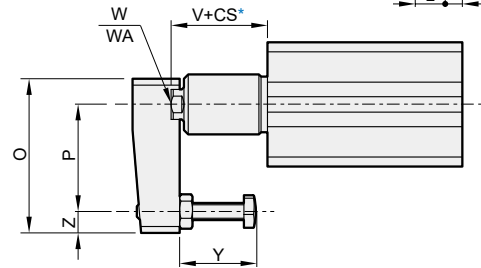
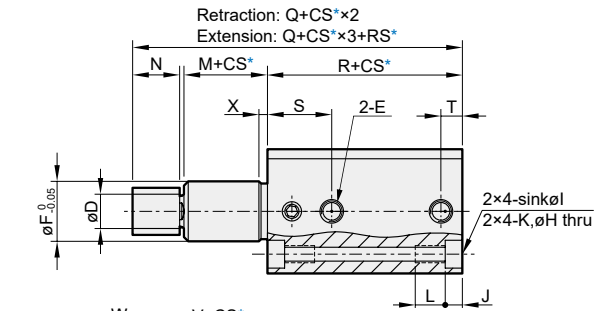
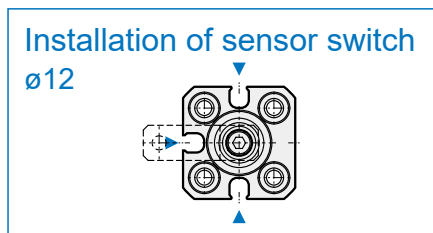
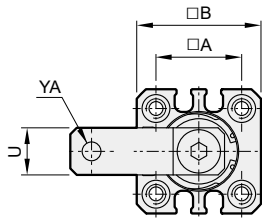

$\phi 20, \phi 25$

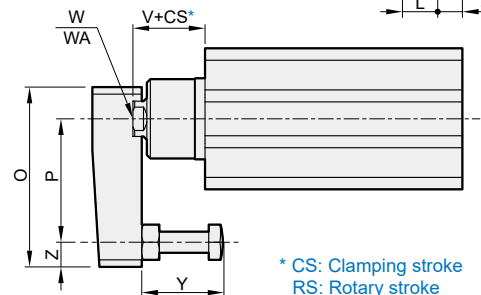
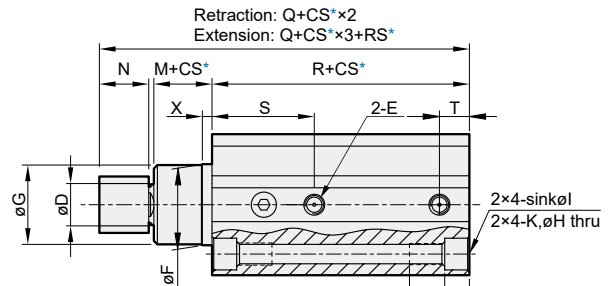
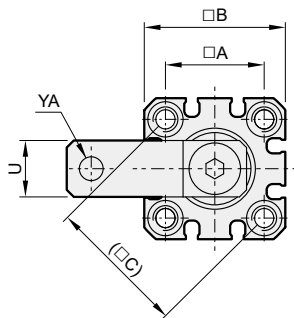

\* CS: Clamping stroke  
RS: Rotary stroke

$\phi 32, \phi 40$

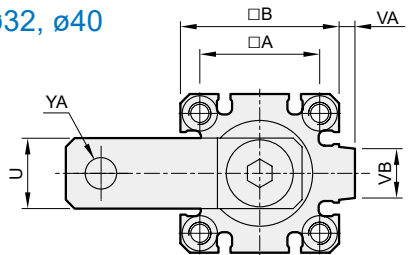

$\phi 50, \phi 63$

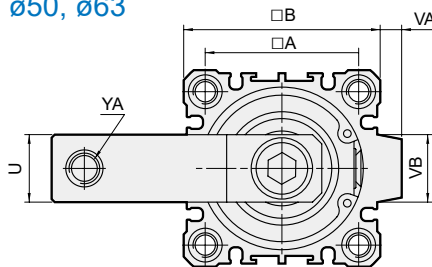

Code Tube I.D.	A	B	C	D	E	F	G	H	I	J	K	L	M
12	15.5	25	-	6	M5×0.8	11 <sup>0</sup> <sub>-0.05</sub>	-	3.5	6.5	4	M4×0.7	7	9.5
16	20	29	-	8	M5×0.8	14 <sup>0</sup> <sub>-0.05</sub>	-	3.5	6.5	4	M4×0.7	7	9.5
20	25.5	36	36	12	M5×0.8	18 <sup>0</sup> <sub>-0.05</sub>	17.9	5.4	9	7	M6×1.0	10	6.5
25	28	40	39.6	12	M5×0.8	23 <sup>0</sup> <sub>-0.05</sub>	22.5	5.4	9	7	M6×1.0	10	6.5
32	34	45	-	16	Rc1/8	30 <sup>0</sup> <sub>-0.05</sub>	29.5	5.5	9	7	M6×1.0	10	15.5
40	40	52	-	16	Rc1/8	30 <sup>0</sup> <sub>-0.05</sub>	29.5	5.5	9	7	M6×1.0	10	23.0
50	50	64	-	20	Rc1/4	37 <sup>0</sup> <sub>-0.05</sub>	36.5	6.6	11	8	M8×1.25	14	28.0
63	60	77	-	20	Rc1/4	48 <sup>0</sup> <sub>-0.062</sub>	47.5	9	14	10.5	M10×1.5	18	27.5

Code Tube I.D.	N	O	P	Q	R	RS	S	T	U	V	VA	VB	W (ROD thread)	WA	X	Y	YA	Z
12	8	29	20	54	35.5	7.5	15	5	8	12.5	-	-	M3×0.5×5.5L	Across flats 5×2.5L	2	7~18	M3×0.5	4
16	11	36	25	57	35.5	7.5	15	5	11	12.5	-	-	M5×0.8×6.5L	Across flats 7×2.5L	2	7~20	M4×0.7	5
20	14	51	35	84	62	9.5	28	8.7	16	10.5	-	-	M8×1.25×14L	Across flats 10×3L	3	12~25	M6×1.0	7
25	14	51	35	85	63	9.5	29	8.5	16	10.5	-	-	M8×1.25×14L	Across flats 10×3L	3	12~25	M6×1.0	7
32	18	67	45	107	71.5	15	28	11	20	22	4.5	14	M10×1.5×19L	Across flats 14×5.5L	3	12~25	M8×1.25	10
40	18	67	45	108	65	15	27	8	20	29.5	5	14	M10×1.5×19L	Across flats 14×5.5L	3	12~25	M8×1.25	10
50	22	88	65	129.5	76.5	19	34	11.5	22	35.5	7	19	M12×1.75×20L	Across flats 17×5.5L	3.5	30~40	M10×1.5	10
63	22	88	65	132.5	80	19	34	10.5	22	35	7	22	M12×1.75×25L	Across flats 17×5.5L	3.5	30~40	M10×1.5	10



Technical data



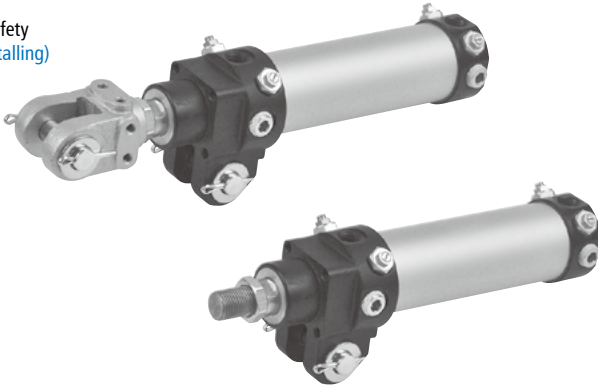

Caution for safety  
(Read before installing)



### Features

- Aluminium alloy tube provides both smooth lines and high corrosion resistance.
- Self lubricated nose bush gives long life.
- Versatile porting position available.
- End cushioning at both ends reduces impact loads.

### Specification

Model	MCKA
Acting type	Double acting
Tube I.D. (mm)	40
Medium	Air
Operating pressure range	0.05~1 MPa
Proof pressure	1.5 MPa
Temperature range	-5~+60°C (No freezing)
Lubrication	Not required
Available speed range	50~500 mm/sec
Cushion	With adjustable cushion at both ends
Sensor switch	RDC, RQC  , RCA 
Sensor switch band	R*C: BKC-1(*), RCA: PN-A40

\* Not for R\*CV angle cable.

### Order example

**MCKA – 40 – 100 M – A**

MODEL

TUBE I.D.

STROKE

50  
75  
100  
125  
150

Blank: With adjustable cushion  
A: With flow adjustable

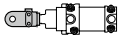
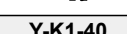
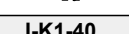

M: Magnet

### Order example of connector

Code	Y	I
Mounting		
Tube I.D.		
ø40	<b>Y-K1-40</b>	<b>I-K1-40</b>

### Order example of pin

Applicable Y & I connector

Code	<b>PIN-1-P</b> (With split pin)
Mounting	
Tube I.D.	
ø40	<b>PIN-K2-50-1-P</b>

### Application examples

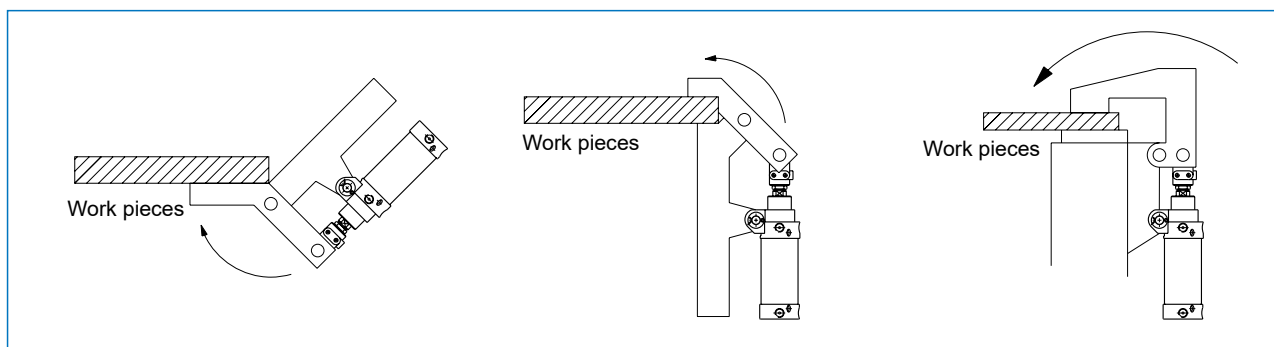

## CLAMP CYLINDER

Mindman

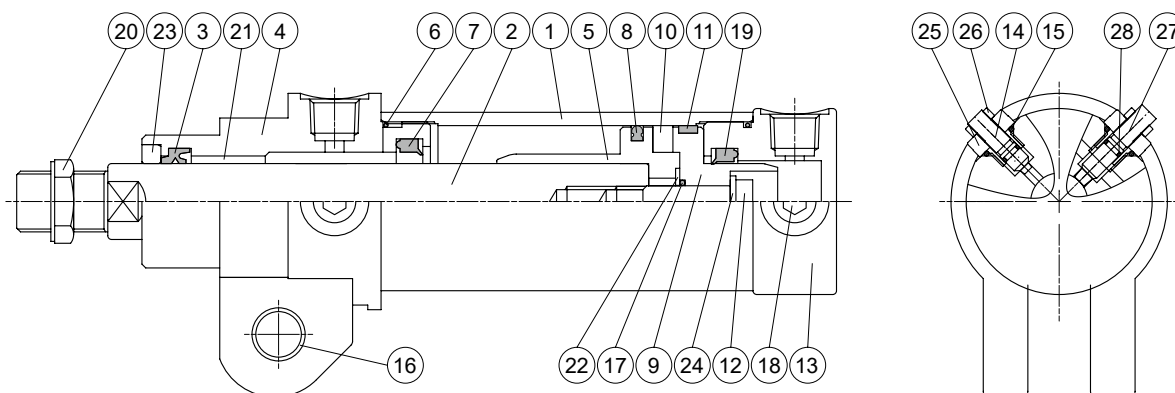

### Material

No.	Part name	Material	Q'y	Component parts (inclusion)	Repair kits (inclusion)
1	Tube	Aluminum alloy	1		
2	Piston rod	Carbon steel	1		
3	Rod packing	NBR	1	●	●
4	Rod cover	Carbon steel	1	●	
5	Piston-R	Aluminum alloy	1	●	
6	Cover ring	NBR	2	●	●
7	Cushion packing-R	NBR	1	●	●
8	Piston packing	NBR	1	●	●
9	Piston-H	Aluminum alloy	1	●	
10	Magnet ring	Magnet material	1	●	
11	Wear ring	Resin	1	●	
12	Piston bolt	SCM	1	●	
13	Head cover	Aluminum alloy	1	●	
14	Cushion needle valve	Copper	2	●	
15	Need valve packing	NBR	4	●	●
16	Bush	Copper	2	●	
17	Piston gasket	NBR	1	●	●
18	Seal screw	Carbon steel	4	●	
19	Cushion packing-H	NBR	1	●	●
20	Rod front nut	Carbon steel	1	●	
21	Rod bush	Copper	1	●	
22	Washer	Carbon steel	1	●	
23	Scraper	Copper	1	●	
24	Washer	Carbon steel	1	●	
25	Lock nut for need valve	Copper	4	●	
26	Adj. nut for need valve	Copper	4	●	
27	Flow needle valve	Copper	2	●	
28	Need valve packing	NBR	4	●	●

### Order example of component parts / repair kits

Tube I.D.	Component parts	Repair kits
ø40	<b>CP-MCKA-40</b>	<b>PS-MCKA-40</b>

CLAMP CYLINDER

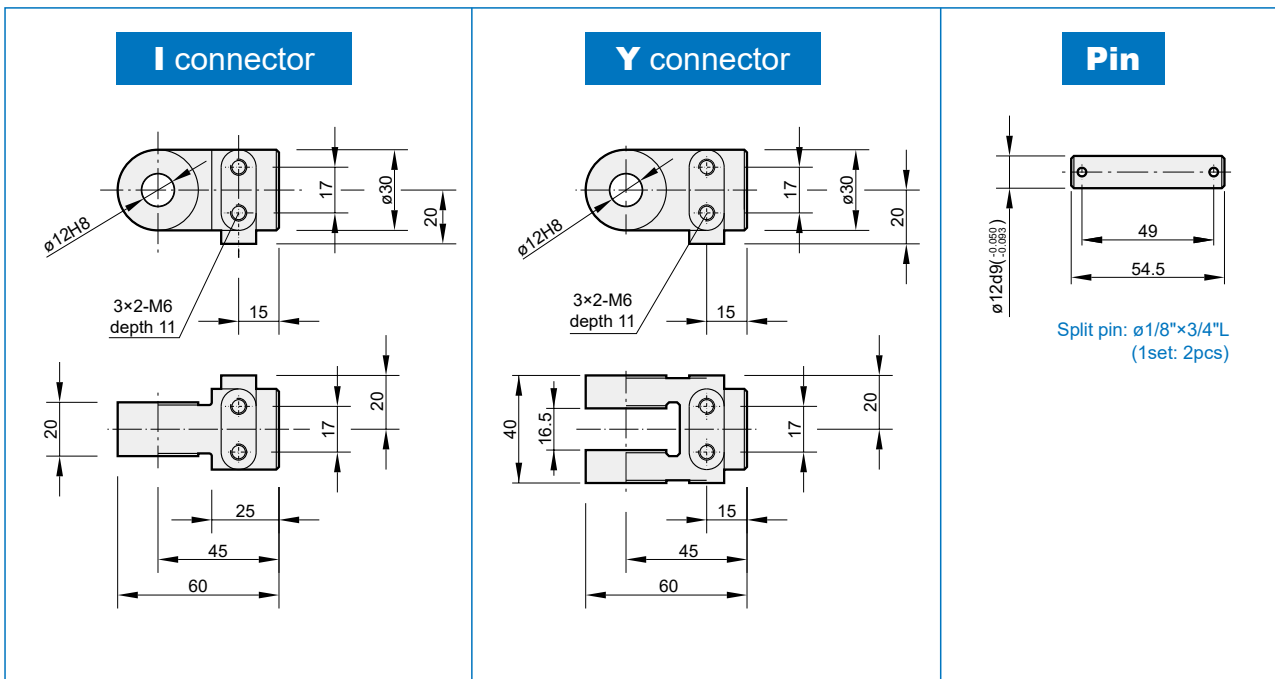
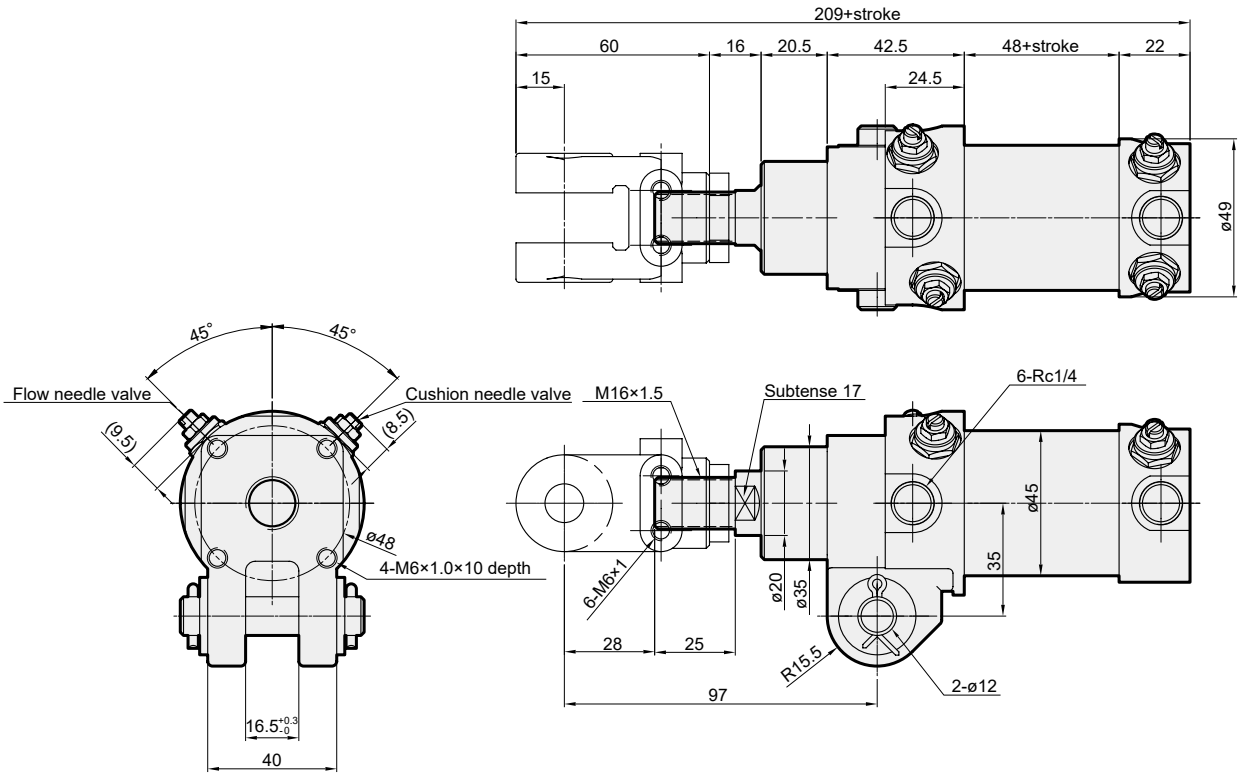



Technical data



Caution for safety  
(Read before installing)

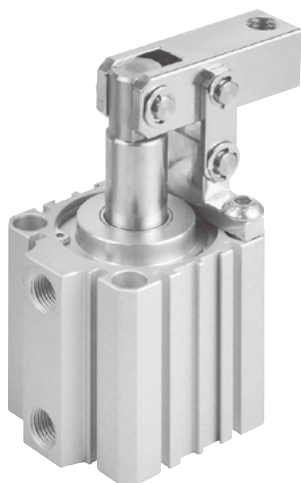

### Order example

**MCKB** — **32** — **25** **M** —

MODEL    TUBE I.D.    STROKE    M: Magnet    PORT THREAD



Blank: M8×0.5  
(Only for ø25)

Blank: Rc thread  
G: G thread  
NPT: NPT thread  
(Only for ø32~ø63)

### Features

- Lever type clamp cylinder gives high clamping force.
- Simple mounting of sensors on all four sides of body.
- Hard anodised body gives smooth lines and high corrosion resistance.

### Specification

Model	MCKB					
Acting type	Double acting					
Tube I.D. (mm)	25	32	40	50	63	
Stroke (mm)	20	25	25	30	35	
Port size	M5×0.8	Rc1/8		Rc1/4		
Operating fluid	Air					
Operating pressure range	0.1~1 MPa					
Proof pressure	1.5 MPa					
Ambient temperature	-5~+60°C (No freezing)					
Lubrication	Cylinder	Not required				
	Lever	Grease				
Available speed range	50~500 mm/sec					
Sensor switch (*)	RCE  , RCE1  , RDEP 					
Weight (g)	Without	233	411	466	832	1111
	Magnet	270	456	578	915	1242

\* RDEP is not suitable for ø63.

### Installation of sensor switch

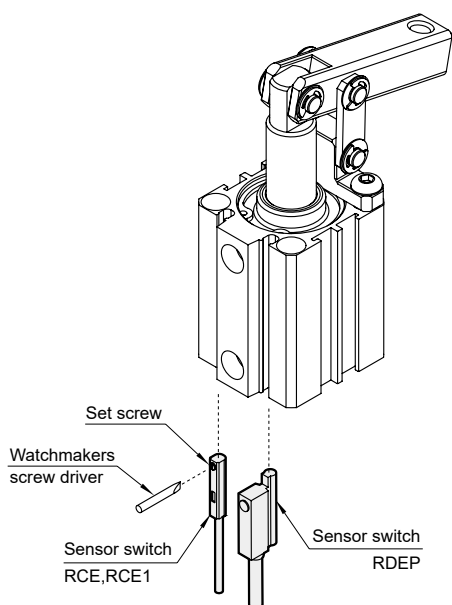

## LEVER CLAMP CYLINDER

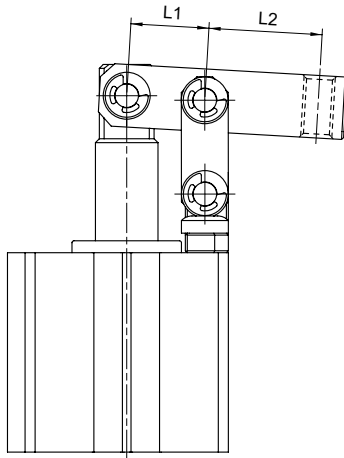

$$T = \frac{F \times L1}{L2}$$

<b>T:</b>	Theoretical clamping force of the lever	(N)
<b>F:</b>	Theoretical output of cylinder	(N)
<b>L1:</b>	Distance from output point to fulcrum	(mm)
<b>L2:</b>	Distance from clamping point to fulcrum	(mm)

Tube I.D. (mm)	Piston area when the lever is down (mm <sup>2</sup> )	Operating pressure (MPa)						Operating pressure (MPa)					
		0.3	0.4	0.5	0.6	0.7	0.8	0.3	0.4	0.5	0.6	0.7	0.8
		Theoretical output (N)						Theoretical clamping force of lever (N)					
25	490.9	147.3	196.3	245.4	294.5	343.6	392.7	61.5	82.1	102.6	123.1	143.6	164.1
32	804.2	241.3	321.7	402.1	482.5	563.0	643.4	108.6	144.8	181.0	217.1	253.3	289.5
40	1256.6	377.0	502.7	628.3	754.0	879.6	1005.3	260.0	346.7	433.3	520.0	606.7	693.3
50	1963.5	589.0	785.4	981.7	1178.1	1374.4	1570.8	471.2	628.3	785.4	942.5	1099.6	1256.6
63	3117.2	935.2	1246.9	1558.6	1870.3	2182.1	2493.8	1169.0	1558.6	1948.3	2337.9	2727.6	3117.2

### Without magnet

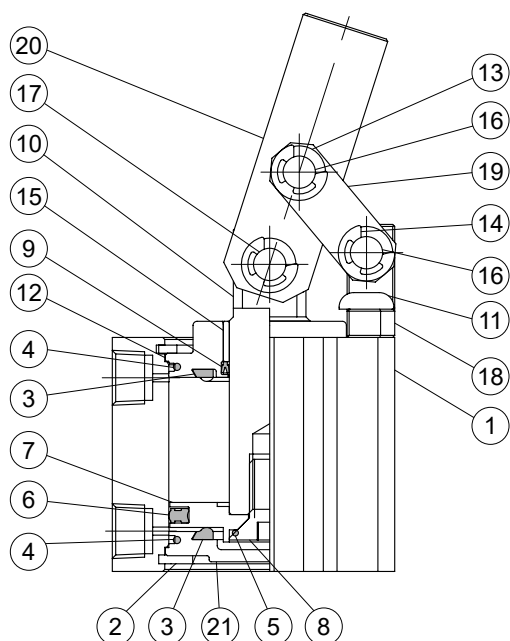

### Magnet

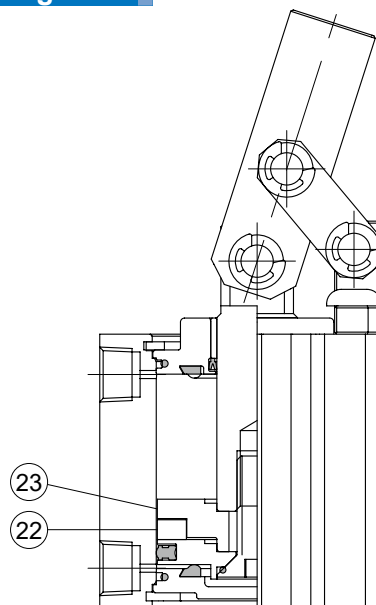

### Material

No.	Part name	Material	Q'y	Repair kits (inclusion)	Note
1	Body	Aluminum alloy	1		
2	Snap ring	Spring steel	2		
3	Cushion	NBR	2	●	
4	Cover gasket	NBR	2	●	
5	Piston gasket	NBR	1	●	
6	Piston packing	NBR	1	●	
7	Piston	Aluminum alloy	1		
8	Piston bolt	SCM	1		
9	Rod packing	NBR	1	●	
10	Piston rod	Carbon steel	1		
11	Screw	SCM	2		
12	Rod cover	Aluminum alloy	1		
13	Washer	Carbon steel	6		
14	Snap ring	Spring steel	6		
15	Rod bush	Bearing alloy	1		ø25 without No.15
16	Connecting pin	Stainless steel	2		
17	Lever pin	Stainless steel	1		
18	Holder	Carbon steel	1		
19	Connecting plate	Carbon steel	2		
20	Lever	Carbon steel	1		
21	Head cover	Aluminum alloy	1		
22	Magnet ring	Magnet material	1		for magnet type only
23	Piston	Aluminum alloy	1		for magnet type only

### Order example of repair kits

Tube I.D.	Repair kits
ø25	<b>PS-MCKB-25</b>
ø32	<b>PS-MCKB-32</b>
ø40	<b>PS-MCKB-40</b>
ø50	<b>PS-MCKB-50</b>
ø63	<b>PS-MCKB-63</b>

## LEVER CLAMP CYLINDER

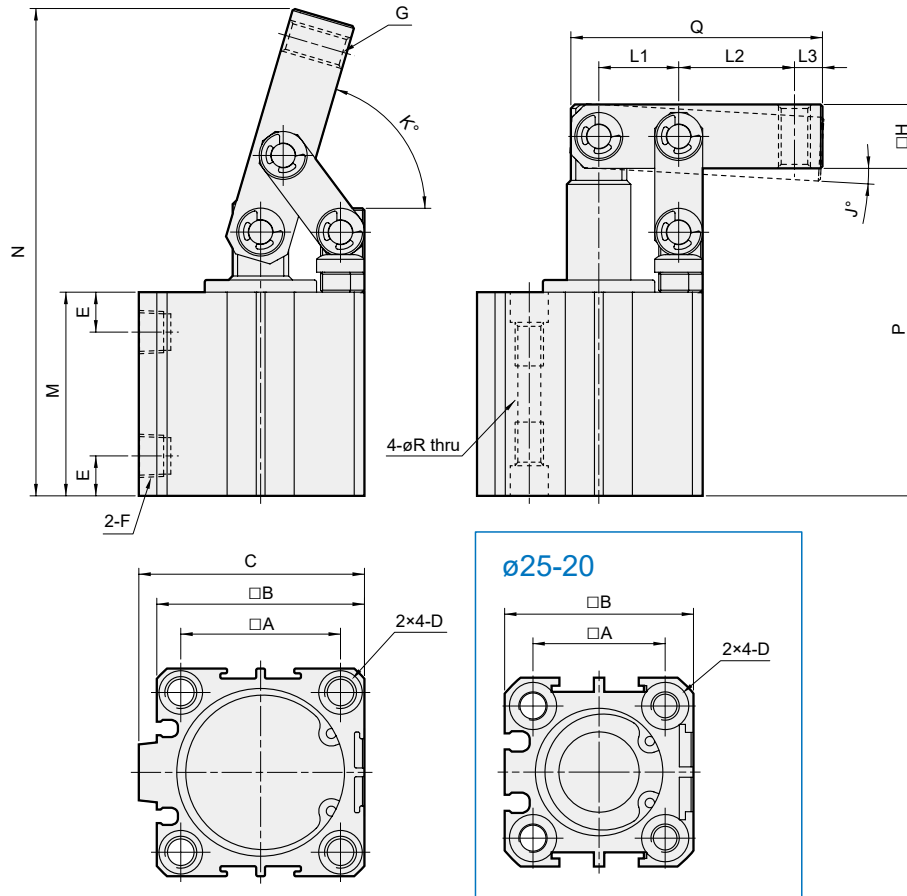

Code Tube I.D.	A	B	C	D	E	F	G	H	J	K	L1	L2	L3
25	28	40	-	$\phi 9 \times 7$ depth, M6 $\times$ 1.0 $\times$ 10 depth	8	M5 $\times$ 0.8	M6 $\times$ 1.0	13	4.5	81.2	14	33.5	5
32	34	44	48.5	$\phi 9 \times 7$ depth, M6 $\times$ 1.0 $\times$ 10 depth	9	Rc1/8	M8 $\times$ 1.25	16	11.9	77.4	18	40	7
40	40	52	56.5	$\phi 10.5 \times 8$ depth, M8 $\times$ 1.25 $\times$ 12 depth	10	Rc1/8	M8 $\times$ 1.25	16	3.3	73.6	20	29	7
50	48	62	70	$\phi 11 \times 8.5$ depth, M8 $\times$ 1.25 $\times$ 16.5 depth	10	Rc1/4	M10 $\times$ 1.5	22	2.6	72.2	24	30	8
63	60	75	83	$\phi 11 \times 8.5$ depth, M8 $\times$ 1.25 $\times$ 16.5 depth	12	Rc1/4	M10 $\times$ 1.5	22	2.1	67.1	30	24	8

Code Tube I.D.	Without magnet			Magnet			Q	R
	M	N	P	M	N	P		
25	41	103.8	63.5	51	113.8	73.5	57	5.1
32	49.5	132.7	80.9	59.5	142.7	90.9	70	5.1
40	51	122	82	61	132	92	63	6.9
50	58	138.5	94	68	148.5	104	70	6.9
63	67	147.5	109	77	157.5	119	70	6.9

