

AUXILIARY EQUIPMENT

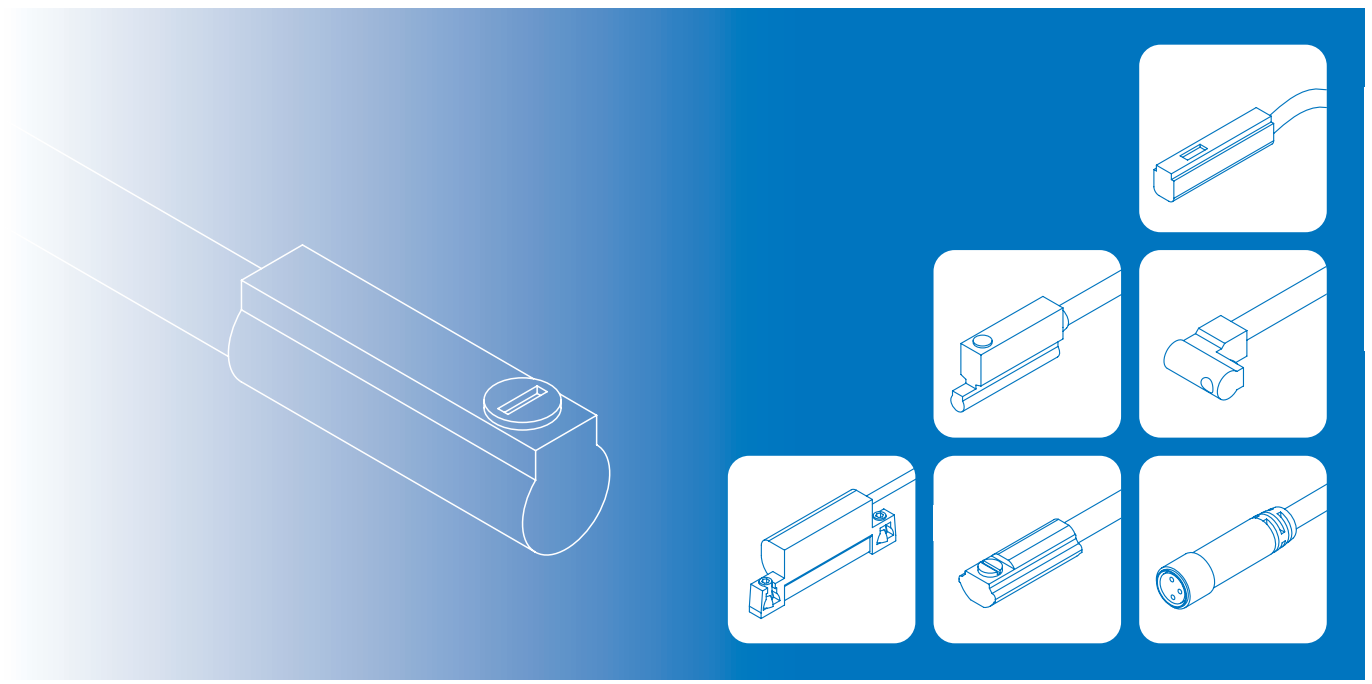

		SENSOR SWITCH	
RC*	RCA.....		5-2
	RCD		5-4
	RCE.....		5-5
	RCE1.....		5-6
	RCI.....		5-7
	RD*	RDC / RQC New	
RDT / RQT New			5-11
RDEP			5-13
RDFE			5-14
RL*	RLG Magnetic position sensor		5-15
	RLZ Linear position sensor		5-16
	RLT Slot-type photomicrosensor ...		5-19
PU-Y974	Slot-type photomicrosensor New		5-20
RJ*	RJY Proximity sensor		5-21
	RJF Proximity sensor		5-22
LN*	LN01G.....		5-23
	LN01P		5-24
	LN32H.....		5-25
	LN65		5-26
		CABLE WITH CONNECTOR	
M8*	M83R(L) / M84R(L) / M88R.....		5-27
	M83R-F		5-28

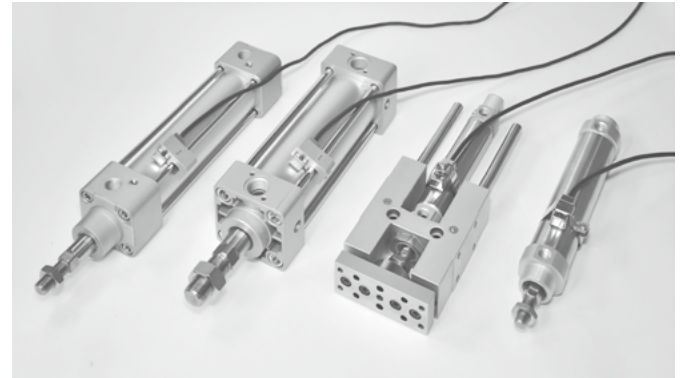

Order example * Special order is available.

RCA – 2M

MODEL

RCA: Reed switch
RDA: Without contact
RNA: NPN
RNAE: NPN
RPA: PNP
RPAE: PNP

WIRE LENGTH

2M: L=2000mm
3M: L=3000mm
QD: M8, 3 Pin connector
EQD: M8, 3 Pin connector

Switch holder / band

HV1

SWITCH HOLDER

HA*: for MCQA, MCQV
HV*: for MCQA, MCQV, MCQV3, MCQV3L, MCBQV, MCBQV3, MCQN
HS*: for MSB*-ø50
PN-A*: for MCKA
PM*: for MCQA, MCQV

Specification

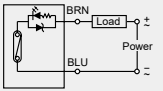
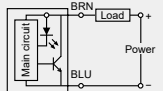
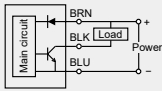
Model	RCA	RDA	RNA	RNAE	RPA	RPAE
Wiring method	2 wire		3 wire			
Switching logic	SPST N.O.	Solid state output, normally open				
Switch type	Reed switch	Non-contact	NPN current sinking		PNP current sourcing	
Operating voltage	5~240V DC/AC		5~30V DC			
Switching current	100mA max.	50mA max.	200mA max.			
Switching rating (*1)	10W max.	1.5W max.	6W max.			
Current consumption	—		15 mA@24V DC max.	6 mA@24V DC max.	15 mA@24V DC max.	6 mA@24V DC max.
Voltage drop	3.5V max.	3.7V max.	1.5V max.	0.5max.	1.5V max.	0.5max.
Leakage current	—	0.1mA(40uA) max.	0.01mA max.			
Indicator	Green LED	Red LED			Green LED	
Cable	ø4, 2C, PVC		ø4, 3C, PVC			
Temperature range	-10~+70°C (No freezing)					
Shock (*2)	30G		50G			
Vibration (*3)	9G					
Enclosure classification	IEC 60529 IP67					
Protection circuit (*4)	1	3,4	2,3,4	3,4	2,3,4	3,4
Weight	46 g (2m cable)					
Connect diagram						

*1. Warning: Never exceed rating (watt=voltage×amperage). Permanent damage to sensor will occur.
 *2. Sin wave / X.Y.Z. 3 directions / 3 times each direction / 11ms each time.
 *3. Double amplitude 1.5mm / 10Hz~55Hz~10Hz(Sweep 1min) / X.Y.Z. 3 directions / 1 hour each time.
 *4. 1=None / 2=Short-circuit / 3=Power source reverse polarity / 4=Surge suppression
 *5. Caution for safety 

Assembling style

Cylinder type	MCQA					MCQV3 / MCBQV3			MCQV		
Mounting clamps	Hold					Hold					
Order	HV2	HV4	PM14	PM16	HA5	HV1	HV2	HV3	HV4	PM16	HA5
Cylinder tube I.D.	40,50,63	80,100	125	150	200	32,40	50,63	80,100	125	160	200
Pictures											

Cylinder type	MCBQV	MCQV3L		MCQN			MCKA	MSB* $\phi 50$
Mounting clamps	Hold	Hold		Hold			Band	Hold
Order	HV4	HV2	HV3	HV1	HV2	HV3	PN-A40	HS
Cylinder tube I.D.	125	63	80	40	50,63	80,100	40	50
Pictures								

Dimension

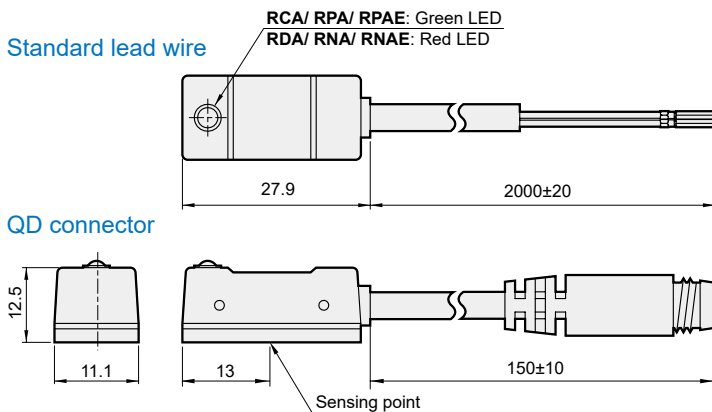

Wiring of the QD

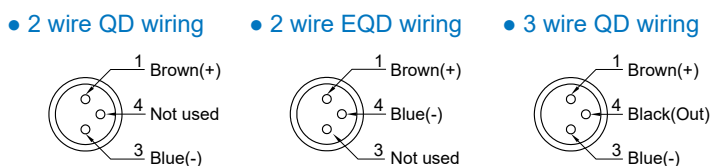

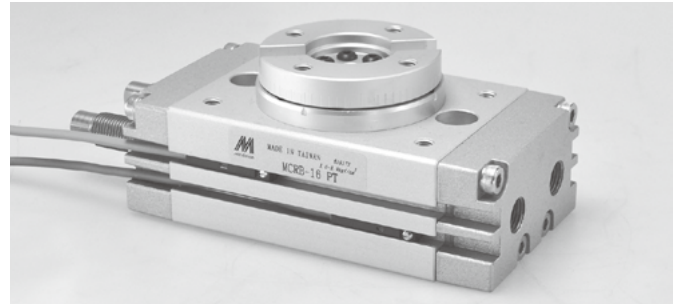

Order example

RCD – 2M

MODEL

RCD: Reed switch
 RDD: Without contact
 RND: NPN
 RNDE: NPN
 RPD: PNP
 RPDE: PNP

WIRE LENGTH

2M: L=2000mm
 QD: M8, 3 Pin connector
 EQD: M8, 3 Pin connector
 * Special order is available.

Assembling style

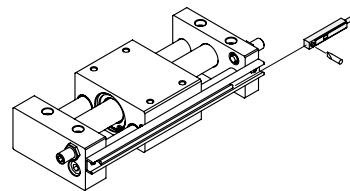
Cylinder type	Mounting clamp
MCRPMS, MCRB	

Dimension

Standard lead wire

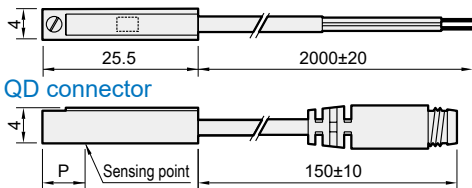

QD connector

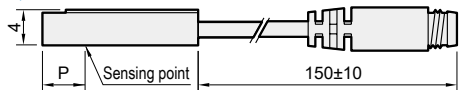

Code Model	P
RCD	12
RDD	6
RND	7.5
RNDE	6
RPD	7.5
RPDE	6

Wiring of the QD

• 2 wire QD wiring

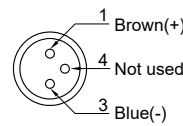



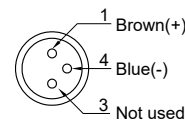

• 2 wire EQD wiring

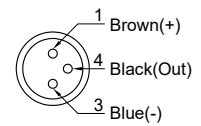

• 3 wire QD wiring

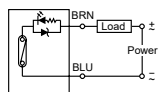
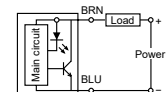

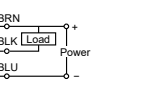
Specification

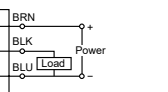
Model	RCD	RDD	RND	RNDE	RPD	RPDE
Wiring method	2 wire		3 wire			
Switching logic	SPST normally open		Solid state output, normally open			
Switch Type	Reed switch	Non-contact	NPN current sinking		PNP current sourcing	
Operating voltage	5~120V DC/AC		5~30V DC			
Switching current	100mA max.	50mA max.	200mA max.			
Contact rating (*1)	10W max.	1.5W max.	6W max.			
Current consumption	-		8 mA@24V DC Max	6 mA@24V DC Max	8 mA@24V DC Max	6 mA@24V DC Max
Voltage drop	3.5V max.	3.7V max.	1V@200mA Max	0.5V@200mA Max	1V@200mA Max	0.5V@200mA Max
Leakage current	-	0.1mA(40uA) Max	0.01mA Max			
Indicator	Red LED				Green LED	
Cable	ø2.8, 2C, PUR		ø2.8, 3C, PUR			
Temperature range	-10~+70°C (No freezing)					
Shock (*2)	30G		50G			
Vibration (*3)	9 G					
Enclosure classification	IEC 60529 IP67					
Protection circuit (*4)	1	3, 4	2, 3, 4	3, 4	2, 3, 4	3, 4
Weight	20 g (2m cable)					
Connect diagram						

*1. Warning: Never exceed rating (watt=voltage×amperage). Permanent damage to sensor will occur.
 *2. Sin wave / X.Y.Z. 3 directions / 3 times each direction / 11ms each time.
 *3. Double amplitude 1.5mm / 10Hz~55Hz~10Hz(Sweep 1min) / X.Y.Z. 3 directions / 1 hour each time.
 *4. 1=None / 2=Short-circuit / 3=Power source reverse polarity / 4=Surge suppression
 *5. Caution for safety 

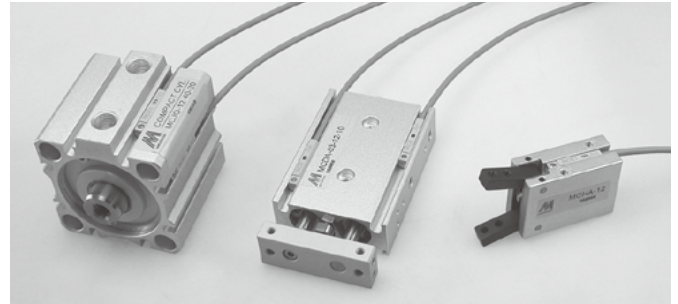

Order example * Special order is available.

RCE — 2M

MODEL

- RCE: Reed Switch
- RDE: Non-contact
- RDE-D: Non-contact, two indicators
- RNEE: NPN
- RPE: PNP
- RPEE: PNP

WIRE LENGTH

- 1M: L=1000mm
- 2M: L=2000mm
- QD: M8, 3 Pin connector
- EQD: M8, 3 Pin connector

Dimension

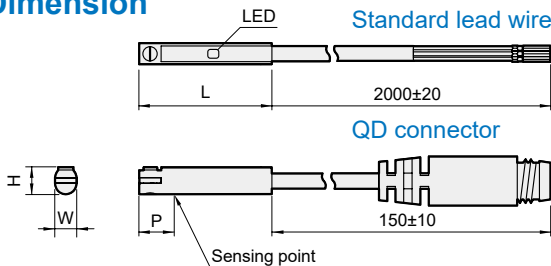

Assembling style

Cylinder type	Mounting clamp
MCJA, MCJQ, MCKJQ, MCFA, MCGB, MCGS, MCGD, MCGJ, MCG3, MCDA, MCSH, MCSS, MCSQ, MCSF, MCRPMD, MCRA, MCKB, MCKC, MCHA, MCHB, MCHC, MSB*, MSL*	

* RDE not applicable to MCDA-12, MCSS-6/8, MCSQ.

Wiring of the QD

- 2 wire QD wiring
- 2 wire EQD wiring
- 3 wire QD wiring

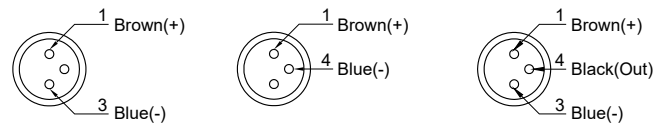

Code Model	H	L	P	W
RCE	5	26	12.5	4
RDE, RDE-D	5	24	6	4
RPE	4.65	22	6	4.1
RNEE, RPEE	5	22	6	4

Specification

Model	RCE	RDE	RDE-D	RNEE	RPE	RPEE
Wiring method	2 wire			3 wire		
Switching logic	SPST N.O.	Solid state output, normally open				
Switch Type	Reed switch	Non-contact		NPN current sinking	PNP current sourcing	
Operating voltage	5~220V DC/AC	10~28V DC		5~30V DC		
Switching current	50mA max.	50mA max.	80mA max.	200mA max.	50mA max.	200mA max.
Switching rating (*1)	10W max.	1.5W max.	2W max.	6W max.	1.5W max.	6W max.
Current consumption (*5)	—			6 mA@24V DC max.	12 mA@24V DC max.	6 mA@24V DC max.
Voltage drop (*5)	3.5V max.		4V max.	0.5V @200mA max.	1.5V max.	0.5V @200mA max.
Leakage current (*5)	—	0.1mA max.	1mA max.	0.01mA max.		
Indicator (LED)	Red		Red/Green (*6)	Red	Green	
Cable	ø2.8,2C,PUR	ø2.8,2C,PUR		ø3, 3C, PU		
Temperature range	-10~+70°C (No freezing)					
Shock (*2)	30G	50G				
Vibration (*3)	9G					
Enclosure classification	IEC 60529 IP67					
Protection circuit (*4)	1	3,4	2,3,4	3,4		
Weight	20 g (2m cable)					
Connect diagram						

*1. Warning: Never exceed rating (watt=voltage×amperage). Permanent damage to sensor will occur.
 *2. Sin wave / X.Y.Z. 3 directions / 3 times each direction / 11ms each time.
 *3. Double amplitude 1.5mm / 10Hz~55Hz~10Hz(Sweep 1min) / X.Y.Z. 3 directions / 1 hour each time.
 *4. 1=None / 2=Short-circuit / 3=Power source reverse polarity / 4=Surge suppression.
 *5. It bases on conditions of voltage 24V DC, ambient temp. 25°C and cable 2M length. Voltage drop increases in pace with cable length.

*6. Red LED: unstable sensing range;
 Green LED: stable sensing range.
 *7. Caution for safety

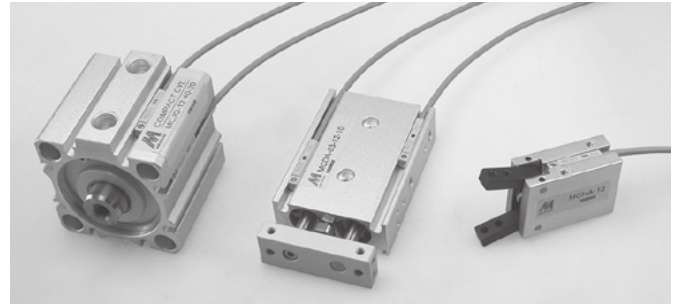

Order example * Special order is available.

RCE1 — 2M

MODEL

RCE1: Reed Switch
RDE1E: Non-contact
RNE1E: NPN
RPE1E: PNP

WIRE LENGTH

1M: L=1000mm
2M: L=2000mm
QD: M8, 3 Pin connector
EQD: M8, 3 Pin connector

Dimension

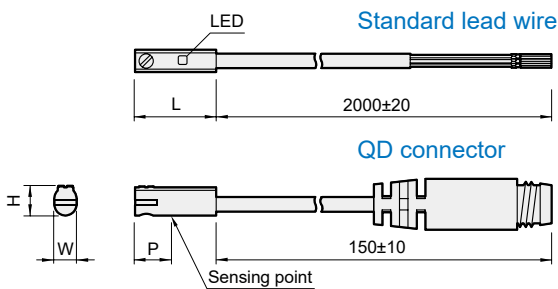

Assembling style

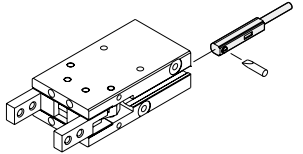
Cylinder type	Mounting clamp
MCJA, MCJQ, MCKJQ, MCFA, MCGB, MCGS, MCGD, MCGJ, MCG3, MCDA, MCSH, MCSS, MCSQ, MCSF, MCRPMD, MCRA, MCKB, MCKC, MCHA, MCHB, MCHC, MSB*, MSL*	

* RNE1E not applicable to MCDA-12.

Wiring of the QD

- 2 wire QD wiring
- 2 wire EQD wiring
- 3 wire QD wiring

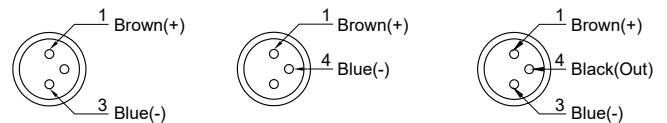

Code Model	H	L	P	W
RCE1	4.65	22.0	12	4.1
RDE1E	5	14.2	6	4
RNE1E	5	14.2	6	4
RPE1E	5	14.2	6	4

Specification

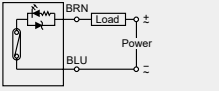
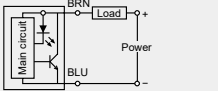
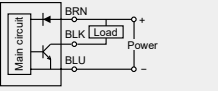
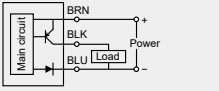
Model	RCE1	RDE1E	RNE1E	RPE1E
Wiring method	2 wire		3 wire	
Switching logic	SPST normally open		Solid state output, normally open	
Switch Type	Reed switch	Non-contact	NPN current sinking	PNP current sourcing
Operating voltage	5~120V DC/AC		5~30V DC	
Switching current	100mA max.	50mA max.	80mA max.	
Switching rating(*1)	10W max.	1.5W max.	2.2W max.	
Current consumption	—		10 mA@24V DC max.	
Voltage drop	3.5V max.		0.5V@50mA max.	
Leakage current	—	0.1mA(40uA) max.	0.01mA max.	
Indicator (LED)	Red			
Cable	ø2.8,2C,PU	ø2.6,2C,PVC	ø2.6,3C,PVC	
Temperature range	-10~+70°C (No freezing)			
Shock (*2)	30G	50G		
Vibration (*3)	9G			
Enclosure classification	IEC 60529 IP67			
Protection circuit (*4)	1	3,4		
Weight	20 g (2m cable)			
Connect diagram				

*1. Warning: Never exceed rating (watt=voltage×amperage). Permanent damage to sensor will occur.

*2. Sin wave / X.Y.Z. 3 directions / 3 times each direction / 11ms each time.

*3. Double amplitude 1.5mm / 10Hz~55Hz~10Hz(Sweep 1min) / X.Y.Z. 3 directions / 1 hour each time.

*4. 1=None / 2=Short-circuit / 3=Power source reverse polarity / 4=Surge suppression

*5. Caution for safety .



Order example

RCI - N - 2M

MODEL

RCI: Reed Switch
 RCI-N: Reed Switch NPN
 RCI-P: Reed Switch PNP
 RNI: NPN
 RPI: PNP

WIRE LENGTH

1M: L=1000mm
 2M: L=2000mm
 3M: L=3000mm
 QD: M8, 3 Pin connector
 EQD: M8, 3 Pin connector

* Special order is available.

Assembling style

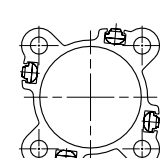
Cylinder type	Mounting clamp
MCQI*, MCKQI*, MCBQI*, MCJI, MCGI, MGTB, MGTU, MGTX, METB	

Specification

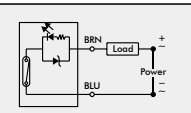
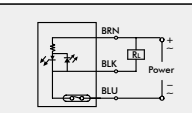
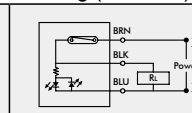
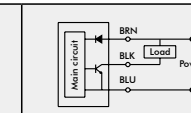
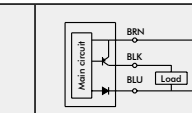
Model	RCI	RCI-N	RCI-P	RNI	RPI
Wiring	2 wire	3 wire		3 wire	
Switching logic	Normal open				
Switch Type	Reed switch	Reed switch NPN	Reed switch PNP	NPN current sinking	PNP current sourcing
Voltage range	5~240V DC/AC	10~30V DC		10~30V DC	
Current range	100mA max.	500mA max.		200mA max.	
Contact rating(*1)	10W max.				6W max.
Current consumption	—	5 mA@24V DC max.		20 mA@24V DC max.	
Voltage drop	3.5V max.	0.1V@100mA max.		1.5V max.	
Leakage current	—	—	—	0.05mA max.	
Indicator	Red LED	Yellow LED		Red LED	Yellow LED
Cable	ø3,2C,PUR	ø3,3C,PUR		ø3,3C,PUR	
Temperature	-10~+70°C (No freezing)				
Shock (*2)	30G			50G	
Vibration (*3)	9G				
Protection classification	IEC 60529 IP67				
Protection circuit (*4)	1			2,3,4	
Weight	23 g (2m cable)				
Connect diagram					

*1. Warning: Never exceed rating (watt=voltage×amperage). Permanent damage to sensor will occur.

*2. Sin wave / X.Y.Z. 3 directions / 3 times each direction / 11ms each time.

*3. Double amplitude 1.5mm / 10Hz~55Hz~10Hz(Sweep 1min) / X.Y.Z. 3 directions / 1 hour each time.

*4. 1=None / 2=Short-circuit / 3=Power source reverse polarity / 4=Surge suppression

*5. Caution for safety 

Dimension

Standard lead wire

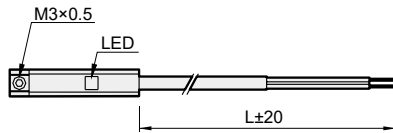

QD connector

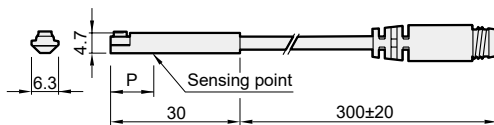

Code Model	P
RCI	13
RCI-N, RCI-P	10
RNI, RPI	8

Mounting

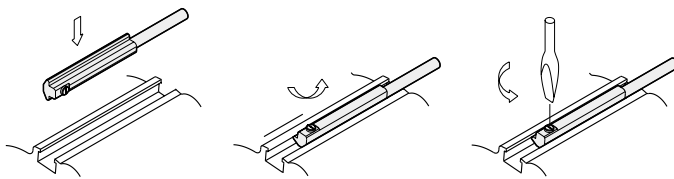

Wiring of the QD

• 2 wire QD wiring

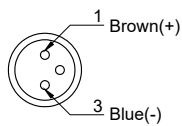

• 2 wire EQD wiring

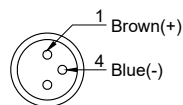

• 3 wire QD wiring

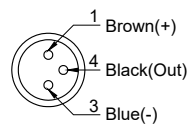



Order example

RDC V – 2M

Model	Auto switch type	Wire length
RDC: Non-contact RQC: NPN & PNP configurations*	Blank: Straight cable V: Angle cable	2M: L=2000mm QD: M8, 3 Pin connector EQD: M8, 3 Pin connector (Only for RDC)

* Selects the mode based on NPN or PNP wiring configuration. Always turn off power before wiring; never work on live wires.

Wiring of the QD

- 2 wire QD wiring
- 2 wire EQD wiring
- 3 wire QD wiring

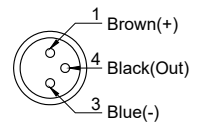
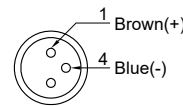
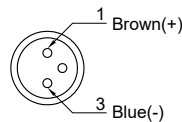

Dimension

Angle cable

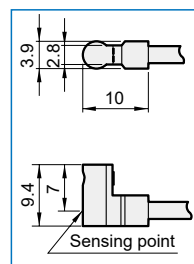

Straight cable

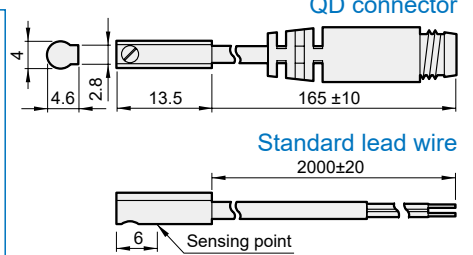

Specification

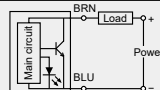
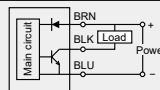
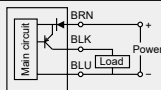
Model	RDC / RDCV	RQC / RQCV	
Wiring method	2 wire	3 wire	
Switching logic		Normally open	
Switch Type	Non-contact	NPN current sinking	PNP current sourcing
Operating voltage		5~30V DC	
Switching current	50mA max.	80mA max.	
Contact rating(*1)	1.5W max.	2.4W max.	
Current consumption (*5)	—	2mA @24V DC max.	
Voltage drop (*5)	4.0V@50mA max.	1.2V @ 80mA max.	
Leakage current (*5)	0.1mA max.	0.01mA max.	
Magnet requirement (*5,6)		40~1000 Gauss	
Indicator		Red LED	
Cable		ø2.6, 27AWG, Black, PVC	
Operating Frequency		1000 Hz	
Temperature range		-10~+70°C (No freezing)	
Shock (*2)		50G	
Vibration (*3)		9G	
Enclosure classification		IEC 60529 IP67	
Protection circuit (*4,7)	3, 4, 5	2, 3, 4	
Weight	17 g (2m cable)	19 g (2m cable)	
Connect diagram			

*1. Warning: Never exceed rating (watt=voltage×amperage). Permanent damage to sensor will occur.

*2. Sin wave / X.Y.Z. 3 directions / 3 times each direction / 11ms each time.

*3. Double amplitude 1.5mm / 10Hz~55Hz~10Hz(Sweep 1min) / X.Y.Z. 3 directions / 1 hour each time.

*4. 1=None / 2=Short-circuit / 3=Power source reverse polarity / 4=Surge suppression / 5=Sensor thermal protection.

*5. It bases on conditions of voltage 24V DC, ambient temp. 25°C and cable 2M length. Voltage drop increases in pace with cable length.

*6. Measuring standard target : ø15.5 × ø8 × 5t (Anisotropy rubber magnet)

*7. The LED will flash when short-circuit or sensor thermal protection is ON.

*8. Please turn off the power before installing or changing the output contact, and ensure the load is installed according to the wiring diagram to prevent abnormal operation or product malfunction.

*9. Caution for safety .

Assembling style

Cylinder model
MAM*, MCJQ3, MCJQ3-3, MCKJQ3, MCJU, MCFA2, MCFB, MCMJP, MCGS2, MCGM2, MCDJ, MGT*-32~63, MCSS2, MCSQ2, MCSF-5, MCSH2, MCRPM-20~40, MCRPMD-10, MCRPMS, MSBE, MCRJ-S, MCRC, MCKC2, MCHB2, MCHCJ, MCHC2, MCHD, MCHH, MCHX, MCHG2, MCHA2, MCHY2, METI, MEQI, MEGT, MEJQ, MESF2, MESBE
Direct mounting

Model	Tube I.D.	Holder	Tie rod	
MCQA	40	DT7-1	ø7.1	
	50			
	63			
	MCQN	80	DT7-3	ø10.8
		100		
		125		
150				
175				
MCQV3 MCBQV3	40	DT7-1	ø6	
	50			
	63			
	MCQV3L	80	DT7-2	ø8.9
		100		
125				
MCQV	32	DT7-1	ø5.3	
	40			
	50			
MCBQV	63	DT7-2	ø7.1	
	80			
	100			
MCQV3L	63	DT7-1	ø7.1	
	80			
	100			
MCQV	125	DT7-3	ø10.8	
	160			
	200			
MCBQV	125	DT7-2	ø10.8	
	150			
DT7-*				

Model	Tube I.D.	Holder with band	
MCMA	16	BKC-1 (Not applicable for Angle cable(V)) 	
	20		
	25		
	32		
	40		
MCMB MCMBR*	20		
	25		
	32		
	40		
MCKMB	20		
	25		
	32		
	40		
MCMBL	32		
	40		
MCM I	8	Mounting steps 	
	10		
	12		
	16		
	20		
	25		
	32		
	40		
	MCBMI MGTK/ B/ U		20
			25
MCMIS	10		
	12		
	16		
	20		
	25		
MCKMI	16		
	20		
	25		
MCMJ	6		
	10		
	16		
MCCG MCCN	20		
	25		
	32		
	40		
	50		
	63		
MCCH	25		
	32		
MCKA	40		

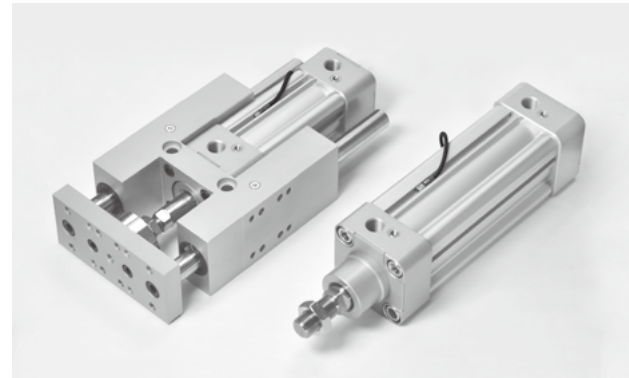

Order example

RDT – 2M

MODEL

RDT: Non-contact
RQT: NPN & PNP configurations*

WIRE LENGTH

2M: L=2000mm
QD: M8, 3 Pin connector
EQD: M8, 3 Pin connect (EQD only for RDT)

* Selects the mode based on NPN or PNP wiring configuration.
Always turn off power before wiring; never work on live wires.

Specification

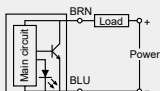
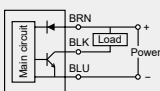
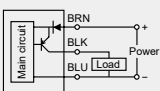
Model	RDT	RQT	
Wiring	2 wire	3 wire	
Switching logic	Normally open		
Switch type	Non-contact	NPN current sinking	PNP current sourcing
Voltage range	5~30V DC		
Switching current	50mA max.	80mA max.	
Contact rating (*1)	1.5W max.	2.4W max.	
Current consumption (*5)	—	2 mA@24V DC max.	
Voltage drop (*5)	4.0V @50mA max.	1.2V@80mA max.	
Leakage current (*5)	0.1mA max.	0.01mA max.	
Magnet requirement (*5,6)	40~1000 Gauss		
Indicator	Red LED		
Cable	ø2.8, 27AWG, Black PVC		
Operating frequency	1000 Hz		
Temperature	-10~+70°C (No freezing)		
Shock (*2)	50G		
Vibration (*3)	9G		
Protection classification	IEC 60529 IP67		
Protection circuit (*4,7)	3, 4, 5	2, 3, 4	
Weight	19.5g (2m cable)	21.5g (2m cable)	
Connect diagram			

*1. Warning: Never exceed rating (watt=voltage×amperage). Permanent damage to sensor will occur.
*2. Sin wave / X.Y.Z. 3 directions / 3 times each direction / 11ms each time.
*3. Double amplitude 1.5mm / 10Hz~55Hz~10Hz(Sweep 1min) / X.Y.Z. 3 directions / 1 hour each time.
*4. 1=None / 2=Short-circuit / 3=Power source reverse polarity / 4=Surge suppression / 5=Sensor thermal protection.
*5. It bases on conditions of voltage 24V DC, ambient temp. 25°C and cable 2M length. Voltage drop increases in pace with cable length.

Wiring of the QD

- 2 wire QD wiring
- 2 wire EQD wiring
- 3 wire QD wiring

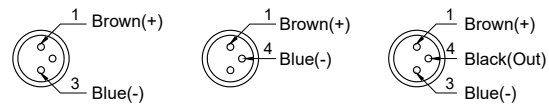



Dimension

Standard lead wire

QD

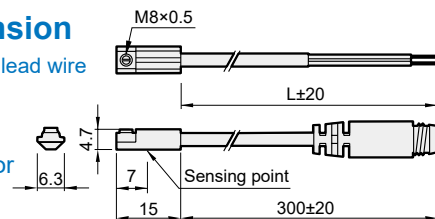
connector



*6. Measuring standard target : ø15.5 × ø8 × 5t (Anisotropy rubber magnet)
*7. The LED will flash when Short-circuit or Sensor Thermal Protection is ON.
*8. Please turn off the power before installing or changing the output contact, and ensure the load is installed according to the wiring diagram to prevent abnormal operation or product malfunction.
*9. Caution for safety 

Assembling style

Cylinder model

MCQI3, MCKQI3, MCBQI3, MCJI, MCGI, MGTB, MGTU, MGTX, MCRPL2-32~40, MCRPLF2-32~63, METB

Direct mounting

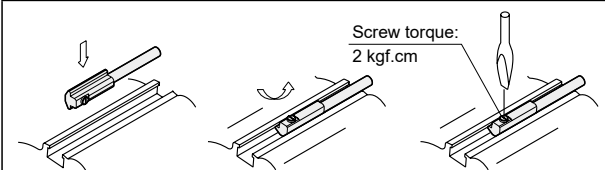

Model	Tube I.D.	Holder	Tie rod
MCQA	200	DT-5	ø19
MCQV	125	DT-3	ø10.8
	160		ø15
	200		
MCQV3 MCBQV3	32	DT-1	ø5.3
	40		ø7.1
	50		
	63	DT-2	ø8.9
	80		
MCQV3L	63	DT-1	ø7.1
	80	DT-2	ø8.9
MCBQV	125	DT-3	ø10.8
	MCRPL2 MCRPLF2	16	HPL2
25		HPL2	

DT-*

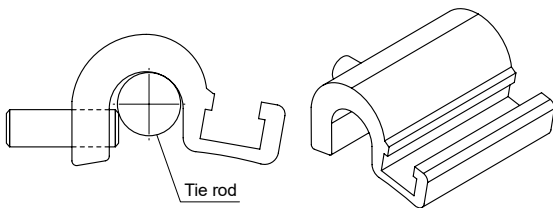

HPL2

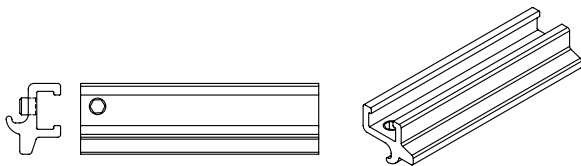

Model	Tube I.D.	Holder with band
MCBMI	20	BKT-1
	25	
MCMi	8	
	10	
	12	
	16	
	20	
	25	
	32	
40		
MCMIS	10	
	12	
	16	
	20	
MCKMI	25	
	16	
	20	
MGTK/ B/ U	25	
	20	

Mounting steps

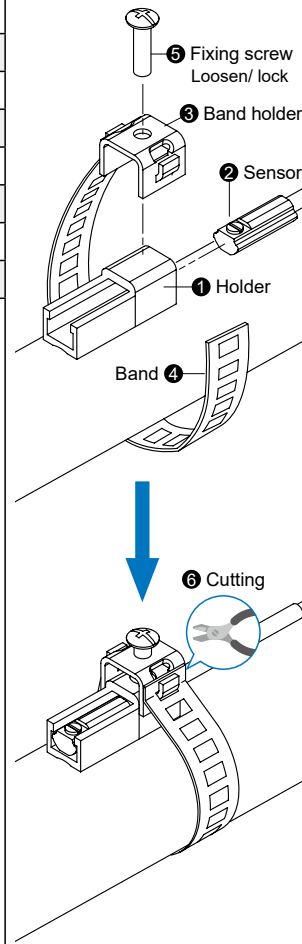

- ⑤ Fixing screw Loosen/ lock
- ③ Band holder
- ② Sensor
- ① Holder
- ④ Band
- ⑥ Cutting

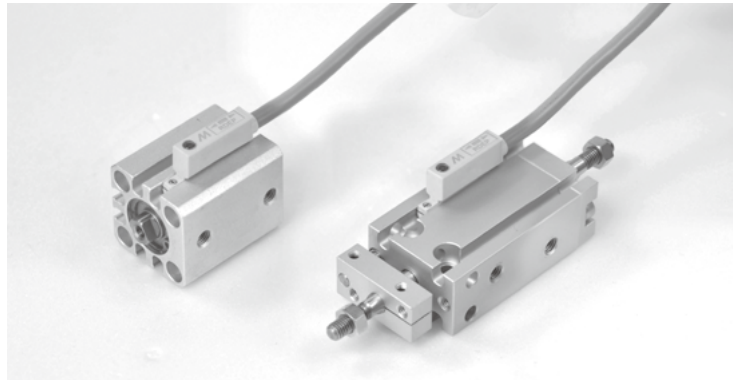

Application environment

- RDEP can be applied in the strong magnetic field environment such as automotive manufacturing or areas near welding machine.
- When RDEP detects the magnetic AC field (50 or 60Hz) it will keep the status of output and will not be effected.

Order example

RDEP — 3M

MODEL WIRE LENGTH
 3M: 3000mm
 QD: M12, 4Pin connector

Dimension

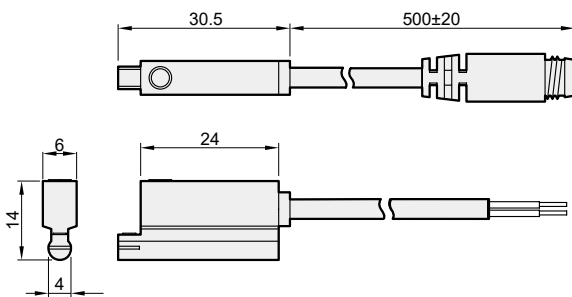

Specification

Model	RDEP
Wiring method	2 wire
Switching logic	Solid state output, normally open
Switch type	Current sourcing
Operating voltage	10~28V DC
Switching current	5~50mA max.
Switching rating (*1)	1.5W max.
Current consumption	—
Voltage drop	5V max.
Leakage current	1mA max.
Indicator	Unstable: Red LED ; Stable: Green LED
Cable	ø4.8, 2C, PVC
Temperature range	-10°C~+60°C (No freezing)
Shock (*2)	50G
Vibration (*3)	9G
Enclosure classification	IEC 60529 IP67
Protection circuit (*4)	3, 4
Weight	100 g (3m cable)
Connect diagram	

- *1. Warning: Never exceed rating (watt=voltage×amperage). Permanent damage to sensor will occur.
- *2. Sin wave / X.Y.Z. 3 directions / 3 times each direction / 11ms each time.
- *3. Double amplitude 1.5mm / 10Hz~55Hz~10Hz(Sweep 1min) / X.Y.Z. 3 directions / 1 hour each time.
- *4. 1=None / 2=Short-circuit / 3=Power source reverse polarity / 4=Surge suppression
- *5. Caution for safety

Wiring of the QD

- 2 wire

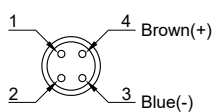

Weld-field immune

The operational distance can be 0mm between sensor and welding gun (welding conductor or cable) when the welding current less than 16000A.

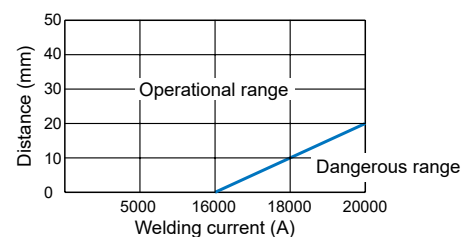

Assembling style

Cylinder type	Mounting clamp
MCJA, MCJQ, MCKJQ, MCFA, MCGB, MCGS, MCGD, MCGJ, MCG3, MCDA, MCSS, MCSH, MCSQ, MCRA, MCKB, MCKC, MSB*, MSL*	



Order example * Special order is available.

RDFE V – 2M

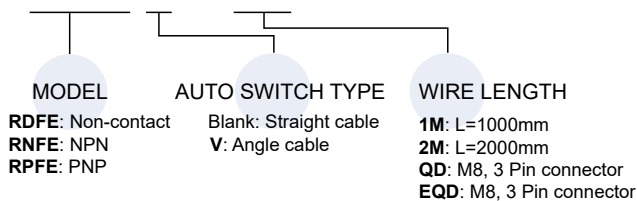

Assembling style

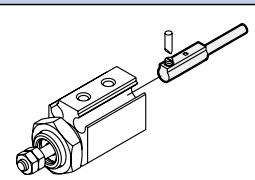
Applicable model	Mounting clamp
MAM*, MCJU, MCFB, MCMJP, MCDJ, MCSF-5, MCRPMS, MSBE, MCRJ-S, MCRQ, MCRQ-S, MCHC-6/32/40, MCHD, MCHH, MCHU, MCHS, MCHX, MCHG2, MCHJ, MCHY, MCRT, MEQI, MESF2, MESBE	

Dimension

Straight cable

Angle cable

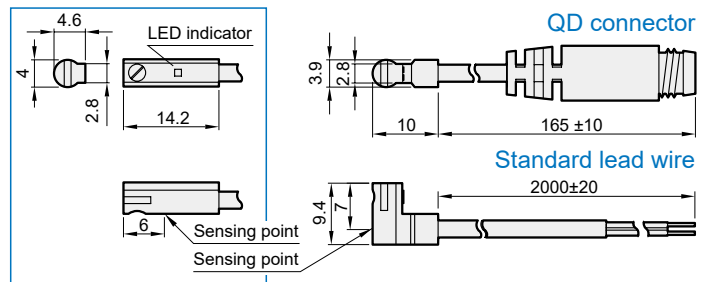

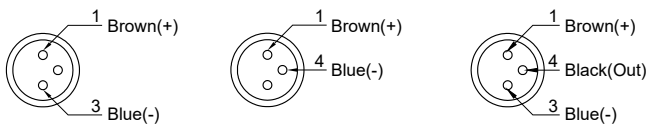

Wiring of the QD

- 2 wire QD wiring
- 2 wire EQD wiring
- 3 wire QD wiring

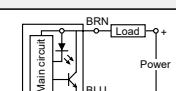
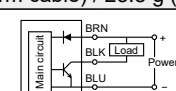
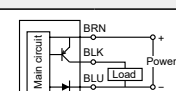

Specification

Model	RDFE / RDFEV	RNFE	RNFEV	RPFE	RPFEV
Wiring method	2 wire	3 wire			
Switching logic	Solid state output, Normally open				
Switch Type	Non-contact	NPN current sinking		PNP current sourcing	
Operating voltage	5~30V DC	5~30V DC		5~30V DC	
Switching current	50mA max.	50mA max.	80mA max.	50mA max.	80mA max.
Contact rating(*1)	1.5W max.	1.5W max.	2.2W max.	1.5W max.	2.2W max.
Current consumption	—	10mA @24V DC max.	6mA @24V DC max.	10mA @24V DC max.	6mA @24V DC max.
Voltage drop	3.5V max.	0.5V @ 50mA max.			
Leakage current	0.1mA(40uA) max.	0.01mA max.			
Indicator	Red LED				
Cable	ø2.6, 2C, PVC	ø2.6, 3C, PVC			
Operating Frequency	1000 Hz				
Temperature range	-10~+70°C (No freezing)				
Shock (*2)	50G				
Vibration (*3)	9G				
Enclosure classification	IEC 60529 IP67				
Protection circuit (*4)	3, 4				
Weight	12.8 g (1m cable) / 23.8 g (2m cable)				
Connect diagram					

*1. Warning: Never exceed rating (watt=voltage×amperage). Permanent damage to sensor will occur.
 *2. Sin wave / X.Y.Z. 3 directions / 3 times each direction / 11ms each time.
 *3. Double amplitude 1.5mm / 10Hz~55Hz~10Hz(Sweep 1min) / X.Y.Z. 3 directions / 1 hour each time.
 *4. 1=None / 2=Short-circuit / 3=Power source reverse polarity / 4=Surge suppression
 *5. Caution for safety 



Order example

RLG – 3N – 2M

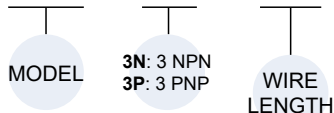

2M: L=2000mm
QD: M12, 5 Pin connector
 * Special order is available.

Wiring of the QD

• 5 wire QD wiring

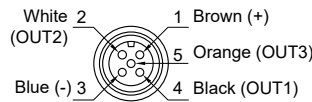

Dimension

Standard lead wire

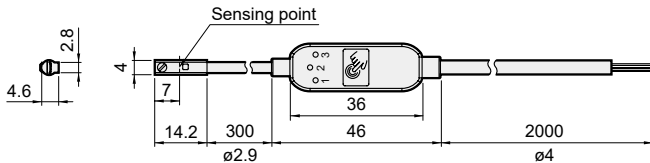

QD connector

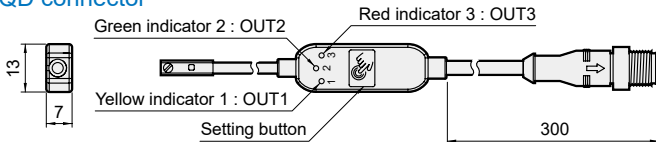

Setting example

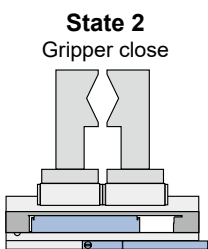
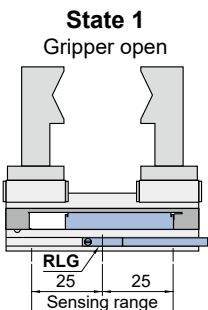

Setting procedure example for state 3

1. Press button once, then long press until three indicators flash.
 2. Keep press button till indicator 3 flashes, then adjust gripper to gripping position.
 3. Long press button to finish.
- * Check manual for more details.

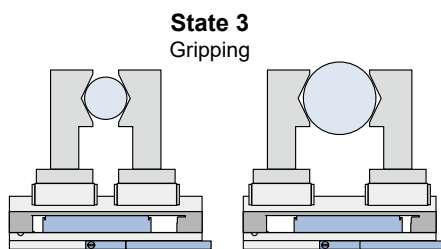

Specification

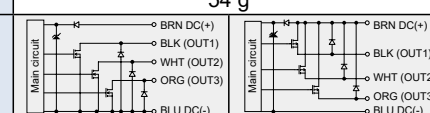
Model	RLG-3N	RLG-3P
Measuring range (*1)	50 mm	
Switching logic	Solid state output, normally open / normally close switchable	
Switch type	3 NPN current sinking	3 PNP current sourcing
Operating voltage	5 ~ 30 V DC	
Switching current (*2)	150 mA max.	
Power supply voltage (*2)	30 V DC	
Contact rating (*2)	4.5 W max.	
Current consumption	20 mA @ 24 V DC max.	
Voltage drop (*2)	1.5 V max. (with resistive load)	
Leakage current	0.01 mA max.	
Repeatability	≤ 0.01 mm	
Indicator	Yellow LED, Green LED, Red LED	
Cable	ø4 PVC - 26 AWG (0.15mm ²) - 5 cores	
Operating frequency	50 Hz	
Magnet requirement (*3)	40 ~ 1000 Gauss	
Temperature range	-10 ~ 70 °C	
Shock (*4)	50 G	
Vibration (*5)	9 G	
Enclosure classification	IEC 60529 IP69	
Protection circuit (*6)	2, 3, 4	
Weight	54 g	
Connect diagram		

- *1. The difference of magnetism, environment, and interference of magnetic field can cause the deviation of measurement.
- *2. The standard is for each output.
- *3. Measuring standard target: ø15.5 × ø8 × 5t (Anisotropy rubber magnet)
- *4. Sin wave / X , Y , Z 3 directions / 3 times each direction / 11 ms each time.
- *5. Double amplitude 1.5 mm / 10 Hz ~ 55 Hz ~ 10 Hz (Sweep 1 min) / X , Y , Z 3 directions / 1 hour each time.
- *6. 1=None / 2=Short-circuit / 3=Power source reverse polarity / 4=Surge suppression.

Assembling style

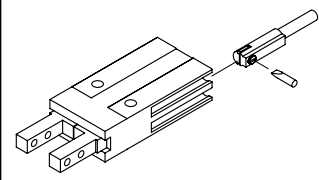
Cylinder type	Mounting clamp
MCJU, MCFB, MCMJP, MGS2, MCDJ, MCSF-5, MSBE, MCRJ-S*, MCRQ*, MCRQ-S, MCHC2-6, MCHD*, MCHH, MCHU, MCHS, MCHX, MCHG2, MCHJ, MCHY2, MCRT, MEQI	

* To ensure good repeatability MCRJ-S, MCRQ-12, MCHD require special specification orders, must use single magnet specification, refer to order example of special cylinder when ordering.

Order example of special cylinder

Standard model no. — **XZ1**

Suitable for RLG series
 * Special cylinder, please contact us



Order example

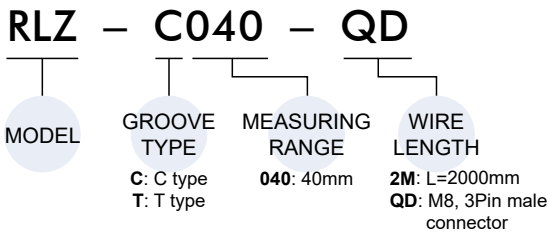

Applicable

For the measurement of dimensions.

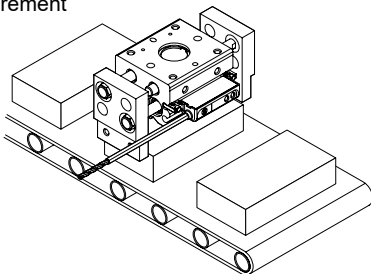

Used to check machined holes.

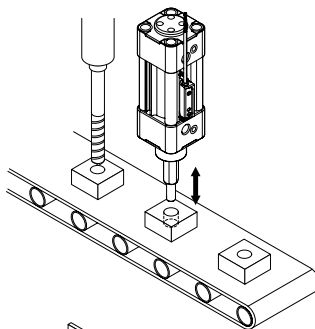

For long/short side detection.

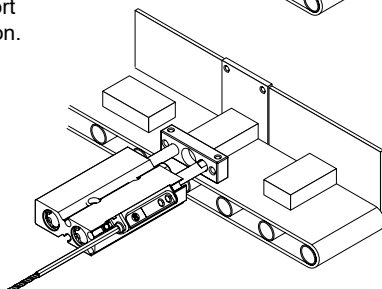

Features

- Repeatability ± 0.01 mm
- Analog output invertible (0~10V \leftrightarrow 10~0V)(4~20mA \leftrightarrow 20~4mA)
- Sampling time ≤ 0.3 ms
- Voltage / current output switchable
- Freely set measuring range

Specification

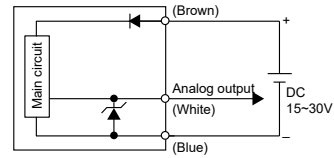
Model	RLZ
Measuring range	40 \pm 1 mm
Power supply voltage	15 ~ 30 V DC, Ripple (P-P) ≤ 10 %
Current consumption	≤ 15 mA (with no load)
Displacement resolution *1	0.001 mm
Linearity error *1	± 0.2 mm @ 25 °C
Repeatability *1	± 0.01 mm @ 25 °C
Sampling time	≤ 0.3 ms
Analog voltage output *2	Voltage Output : 0 ~ 10 V Min. Load Impedance : 2 K Ω Linearity : ± 0.05 % F.S. @ 25 °C Sensitivity : 0.25 mV/ μ m
Analog current output *2	Current Output : 4 ~ 20 mA Max. Load Impedance : 500 Ω Linearity : ± 0.05 % F.S. @ 25 °C Sensitivity : 0.4 μ A/ μ m
Magnetic field strength*1,3	20 ~ 200 Gauss
Enclosure	IP69 IEC 60529
Ambient temp. Range	Operation : 0 ~ 50 °C, Storage : -10 ~ 60 °C (No condensation or freezing)
Ambient humidity range	Operation / Storage : 35 ~ 85 % RH (No condensation)
Withstand voltage	1000 V AC in 1-min (between case and lead wire)
Insulation resistance	≥ 50 M Ω (at 500 V DC, between case and lead wire)
Shock *4	30 G
Vibration *5	10 G
Lead wire	$\phi 2.9$ PUR - 26 AWG (0.15mm ²) - 3 cores
Protection circuit	Power source reverse polarity, Surge suppression
Weight (with 2M lead wire)	Approx. 33 g (C type), Approx. 37 g (T type)
Connect diagram	

*1. Measuring standard target : $\phi 15.5 \times \phi 8 \times 5t$ (The movement of anisotropy rubber magnet and piston are from same direction.)

*2. Only one of analog output can be selected while setting.

*3. The difference of magnetism, environment, and interference of magnetic field can cause the deviation of measurement.

*4. Sin wave / X , Y , Z 3 directions / 3 times each direction / 11 ms each time.

*5. Double amplitude 1.5 mm or 10 G / 10 Hz ~ 55 Hz ~ 10 Hz (Sweep 1 min) / X, Y, Z 3 directions / 2 hours each time.

*6. Caution for safety .

⚠ Caution

- * The repeatability of sensor will be affected by the operational condition and environment.
- * Avoid piston and magnet of cylinder spin to cause inaccuracy.
- * To ensure good repeatability, models marked with ● require special specification orders.

● Standard cylinder
 ● Special cylinder

	Model	Stroke Tube I.D.	5	10	15	20	25	30	40	50	60	80	100	150	200	250	300	400	500				
Mini	MCMJP (C type)	10					●	●															
		16					●	●	●														
Guide cylinder	MCGI (T type)	20,25				●	●	●	●	●	●	●	●										
		32,40			●	●	●	●	●	●	●	●	●	●	●	●							
		50			●	●	●	●	●	●	●	●	●	●	●	●	●	●					
		63,80,100		●	●	●	●	●	●	●	●	●	●	●	●	●	●	●					
	MCDJ (C type)	6				●		●	●	●													
10			●		●		●	●	●														

	Model	Tube I.D. Spec.	6	8	10	12	16	20	25	32	40	50	63	80	100	125	160	200	300				
Cylinder	MCKQI3 (T type)									●	●												
	MGTB/U/X *1 (T type)									●	●												
Rotary actuator	MCRJ-S (C type)	90°																					
		180°	●	●																			
	MCRQ (C type)	90°				●	●	●	●	●													
		180°				●	●	●	●	●													
Gripper	MCHD (C type) *2	Short				●	●	●															
		Medium		●*3		●	●	●															
		Long		●		●	●	●															
	MCHU (C type)					●	●	●															
	MCHS (C type)																	●	●	●			
	MCHX (C type)				●		●	●	●	●	●	●											
MCHY2 (C type)				●		●	●	●	●														

- *1. The cylinders for MGTB/U/X are MCKQI3.
- *2. MCHD must use single magnet specification.
- *3. Please install the sensor in the middle of MCHD-8 medium stroke (as shown in Figure 2).
- *4. The built-in magnets must be glued except *2.
- *5. RLZ is also applicable to the models marked with ● in standard specification if good repeatability is not required. (except MCHD and MCRQ-12 series)
- *6. Please contact us if required models not found in the table.

Order example of special cylinder

Standard model no. — XZ1

Suitable for RLZ series
 * Special cylinder, please contact us

Installation

Move the sensor to the required position, then tighten the screw by hexagon wrench 2.0 mm with tightening torque 0.2 ~ 0.4 Nm (as shown in Figure 1).

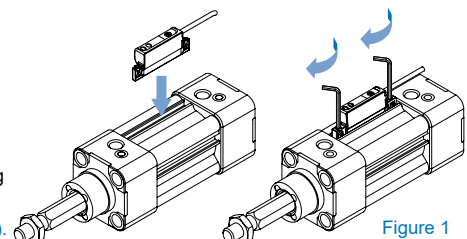

⚠ Precautions (Read before installing)

- Be sure to tighten within the recommended tightening torque when mounting the actuator position sensor.
- According to the installation condition, the cylinder may not operate even when mounted appropriately. If the sensor doesn't work, try following solutions: 1. Restart the power. 2. Operate the cylinder for several times.
- Turn off power before connecting wiring. Wrong wiring or short circuit will damage and / or cause malfunction.

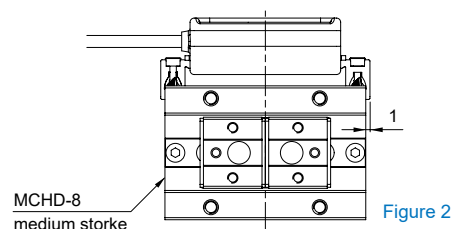

Wiring of the QD

- 3 wire QD wiring

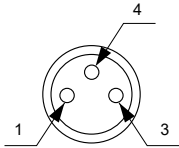

- 1 Brown(+)
- 3 Blue(-)
- 4 White (analog output)

Analog output function

- Analog voltage / current output can be switched.
- Analog output can be inverted.

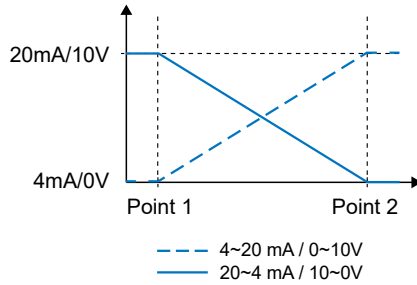

Information indicator LED color description

Please ensure that the required measurement range of the cylinder is within the measurement range of RLZ.

Default setting



Resetting

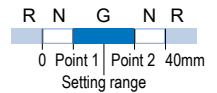

Description	
G (Green)	Within the setting range
N (Non)	Within the measuring range, but outside the setting range.
R (Red)	Outside the measuring range

Dimensions

RLZ-C

C type

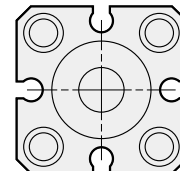
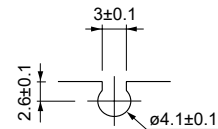
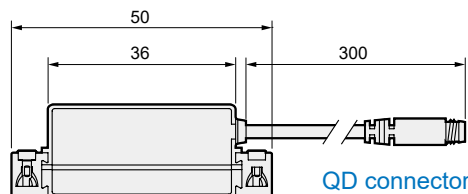
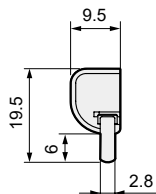
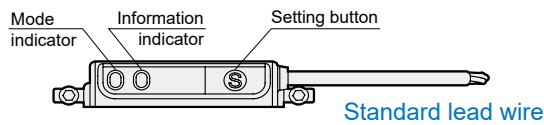

RLZ-T

T type

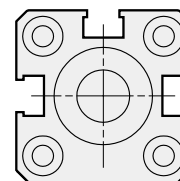
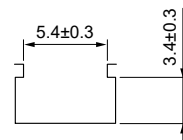
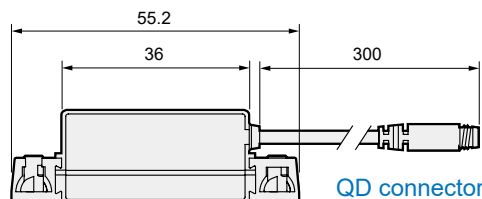
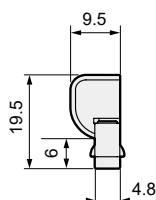
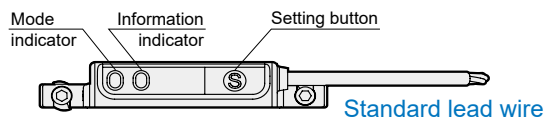

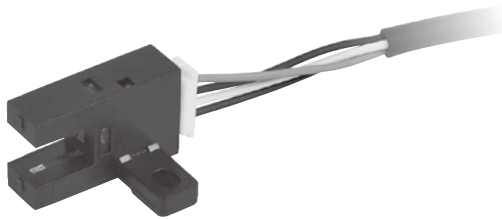

Order example

RLT — N — □

MODEL

SWITCH TYPE
N: NPN
P: PNP

WIRE LENGTH
Blank: Without
2M: L=2000mm

* Special order is available.

Dimension

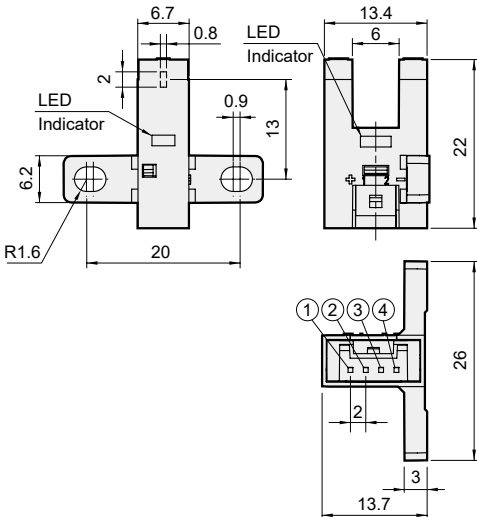

①	+	Brown	8~24V DC
②	1	Black	Output 1 (NC)
③	2	White	Output 2 (NO)
④	-	Blue	GND (0V)

Specification

Model	RLT-N	RLT-P
Sensing distance	6 mm (slot width)	
Sensing object	Opaque: 2×0.8mm min.	
Switch type	NPN current sinking	PNP current sourcing
Differential distance	0.025 mm max.	
Light source (Peak wavelength)	Infrared LED with a peak wavelength of 940 nm	
Indicator	Light indicator (Red LED)	
Supply voltage	8~24 VDC ± 10%, ripple (p-p): 10% max.	
Current consumption	20 mA max.	
Control output	Load power supply voltage: 8~24 VDC Load current: 50 mA max Off-stage current: 0.5 mA max. 50 mA load current with a residual voltage of 1.0 Vmax. 19 mA load current with a residual voltage of 0.4V max.	
Protection circuit	Power supply reverse polarity protection; output reverse polarity protection: overcurrent protection	
Response frequency	1 kHz min. (2 kHz average)	
Ambient illumination	1000 lx max. with fluorescent light on the surface of the receiver	
Ambient temperature	Operating: -25~55°C, Storage: -30~80°C (with no icing or condensation)	
Ambient humidity range	Operating: 5~85% RH, Storage: 5~95% RH (with no icing or condensation)	
Vibration resistance (Destruction)	10~2000 Hz 0.75-mm single amplitude (15-min periods, 10 cycles) each in X, Y and Z directions	
Shock resistance (Destruction)	Destruction: 500 m/s ² for 3 times each in X, Y and Z directions	
Degree of protection	IEC 60529 IP50	
Connecting method	Connector	
Case material	Acrylonitrile butadiene styrene (ABS)	
Weight (Packed state)	Approx. 3g	
Connect diagram		

* 1. Caution for safety

Assembling style

Cylinder type	Mounting
METFB, METS2 MESH2, MESS2	

PU-Y974 series

SLOT-TYPE PHOTOMICROSENSOR



Mindman

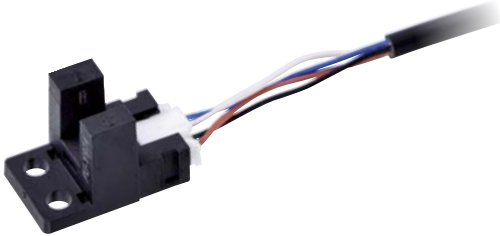

Order example

PU — Y974 P — □

MODEL

SWITCH TYPE

WIRE LENGTH

Blank: NPN
P: PNP

Blank: Without
2M: L=2000mm

Assembling style

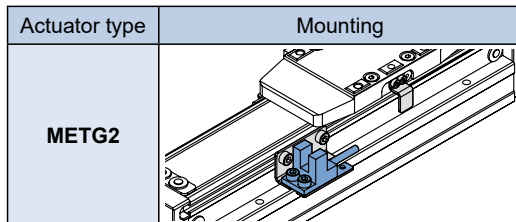

Dimension

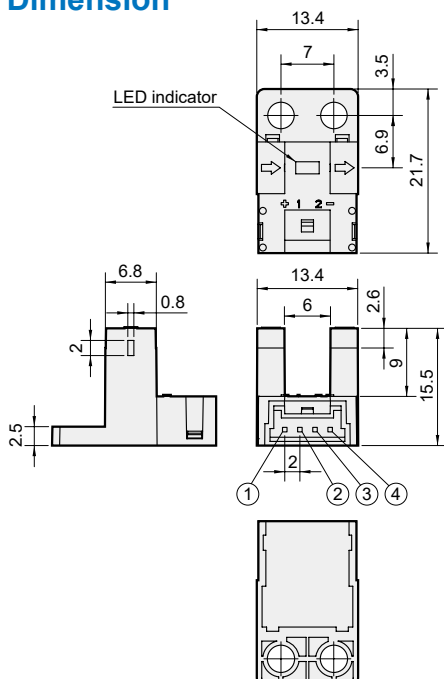

Specification

Model	PU-Y974	PU-Y974P
Detection distance	6 mm (slot width)	
Standard detection object	Opaque objects larger than 2×0.8 mm	
Sensing distance	≤ 0.025 mm	
Contact type	NPN	PNP
Switch mode	Switchable between L.on (Light ON mode) and D.on (Dark ON mode)	
Indicator light	When an object is detected, the light turns off; when no object is present, the light remains on	
Response frequency	2KHz	
Light source	Infrared LED	
Operating voltage	5~24 VDC±10%, ripple (p-p) less than 10%	
Residual voltage	1V or below (at a load current of 50mA)	
Current consumption	≤15 mA	
Protection circuit	Reverse power protection	
Ambient light intensity	Illuminance on the receiving surface: Below 1000 lux	
Ambient temperature	Operating: -25~+55°C, Storage: -30~+80°C (No condensation and freezing)	
Ambient humidity	Operating: 5~85%RH, Storage: 5~95%RH (No condensation and freezing)	
Vibration resistance	10~2000 Hz, single amplitude 0.75mm, X, Y, and Z directions, Scan time: 15 minutes, Scan times: 10 times	
Degree of protection	IP50	
Case material	ABS	
Wiring method	Connector	
Wight	3 g	
Connect diagram		

* Caution for safety

①	Brown	8~24V DC
②	Black	Output 1 (NC)
③	White	Output 2 (NO)
④	Blue	GND (0V)

Wire

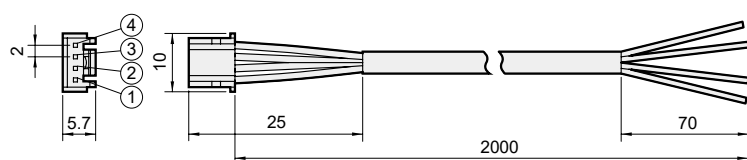

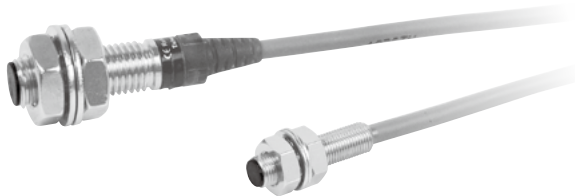

Order example

RJY – N – M8 – 3M

MODEL	SWITCH TYPE	Body thread	Wire length
	N: NPN P: PNP	M5	2M: 2000mm
		M8	3M: 3000mm

Dimension

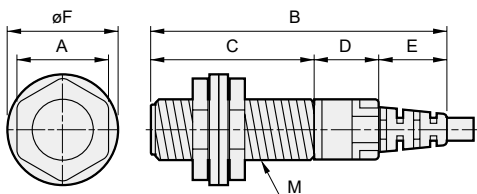

Code Model	A	B	C	D	E	F	M
RJY*-M5	7	-	20	-	-	8	M5×0.5
RJY*-M8	12	39	21.5	8.5	9	15.5	M8×1.0

Connect diagram

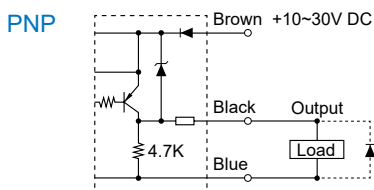
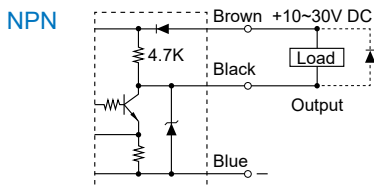

Specification

Model	RJY	
Body thread	M5	M8
Operating voltage	10~30V DC	
Power ripple	20% peak to peak	
Current consumption (mA)	10 max.	
Detection distance (mm)	1.0±0.2 (steel)	1.8~2.0 (steel) 0.4~0.6 (aluminum)
Hysteresis	10% of sensing distance max.	
Response frequency (KHz)	2.5 min.	
Output type	NPN, PNP	
Output logic	N.O.	
Output current (mA)	100 max.	150 max.
Residual voltage (V)	0.1 max.	
Leakage current (mA)	0.8 max.	
Protection type	Short circuit & polarity reversed protection	
Indicator (LED)	Green	White
Cable	3c/ø3 Gray cover, oil and shaking resistance	
Maximum voltage resistance	2.5kv / 1 minute min.	
Operating environment	-20°C ~ +80°C, 35% ~ 85% RH	
Protection class	IP 67	

* Caution for safety 

Assembling style

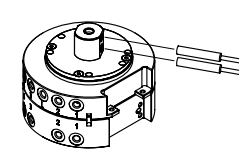
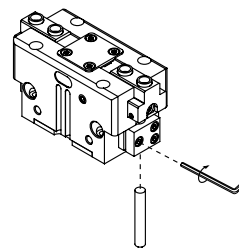
Model	Cylinder type	Mounting clamp
RJY*-M5	MCTC MSBE-32	
RJY*-M8	MCHJ MCHS MSBE MESBE	

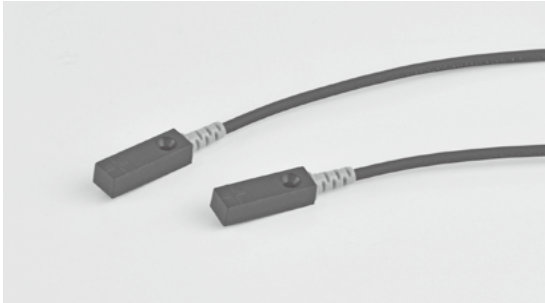

Order example

RJF — N — 2M

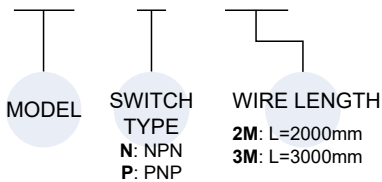

Dimension

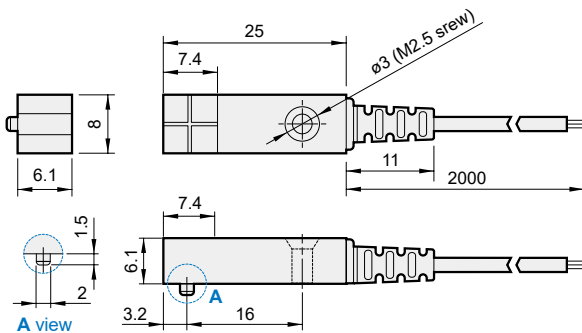

Specification

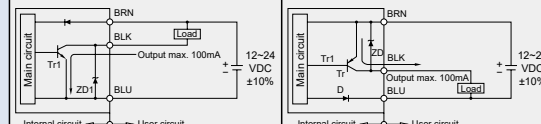
Model	RJF-N	RJF-P
Supply voltage	12~24VDC± 10%, Pulsation(P-P)10% less	
Current consumption	<10mA	
Load current	100mA	
No load current	<0.01mA No-load	
Detection distance	0~2 mm	
Min. detection object	1×8×8 (Iron)	
Ripple	<1.5VDC(Load 100mA,wire 2M)	
Repeat accuracy	<1% Detection distance	
Frequency	600 HZ	
Power reverse connection protection	Yes	
Output short circuit protection	Yes	
Switching output	NPN, N.O.	PNP, N.O.
Ambient operating temperature	-25 ~ 70°C	
Temperature drift	<10% Detection distance	
Enclosure rating	IP67	
Voltage withstand	100VAC 50~60HZ 1min	
Insulation resistance	>20MΩ	
Connection type	ø3×2M/3M, 3-wires	
Housing material	ABS/PBT	
Accessories	M2.5 screw ×1, M2.5 nut ×1	
Weight	Approx. 24g (2M), 36g (3M)	
Connect diagram		

* Caution for safety 

Assembling style

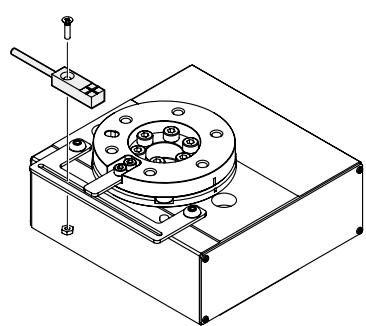
Cylinder type	Mounting
MERE	

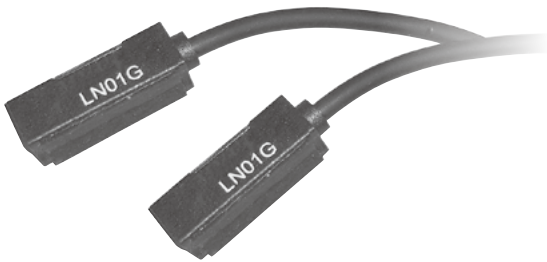

Specification

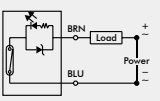
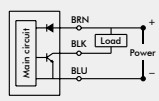
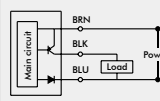
Model	LN01G	LN01G-N	LN01G-P
Wiring method	2 wire	3 wire	
Switching logic	Normally open	Solid state output, normally open	
Switch Type	Reed switch	NPN current sinking	PNP current sourcing
Operating voltage	5~240V DC/AC	5~30V DC	
Switching current	100mA max.	200mA max.	
Switching rating(*1)	10W max.	6W max.	
Current consumption	—	OFF:7mA(24V) ON:20mA(24V) max.	
Voltage drop	3V max.	0.5V@200mA max.	
Indicator	Red LED		Green LED
Cable	ø3.3, 2C, PVC	ø3.3, 3C, PVC	
Temperature range	-10~+70°C (No freezing)		
Enclosure classification	IEC 60529 IP67		
Protection circuit (*2)	1	3, 4	
Symbol			

Order example

LN01G — P — □

MODEL



Blank: Lead wire
QD: Connector

SWITCH TYPE
Blank: Reed switch
N: NPN
P: PNP

*1. Warning: Never exceed rating (watt=voltage×amperage).

*2. 1=None / 2=Short-circuit / 3=Power source reverse polarity / 4=Surge suppression.

*3. Caution for safety .

Assembling style

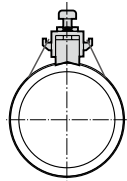
Cylinder type	Mounting clamp
MDO*	

Dimension

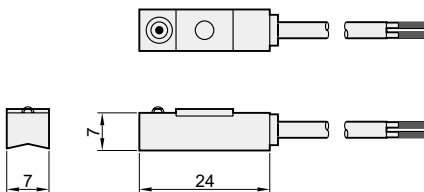

Wiring of the QD

• 2 wire QD wiring

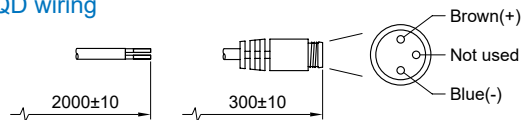

• 3 wire QD wiring

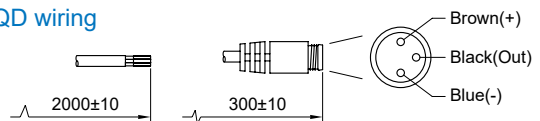



Specification

Model	LN0*P	LN0*P-AN	LN0*P-AP
Wiring method	2 wire	3 wire	
Switching logic	Normally open	Solid state output, normally open	
Switch Type	Reed switch	NPN current sinking	PNP current sourcing
Operating voltage	10~220V DC/AC	5~30V DC	
Switching current	100mA max.	200mA max.	
Switching rating(*1)	10W max.	6W max.	
Current consumption	—	OFF:7mA(24V) ON:20mA(24V) max.	
Voltage drop	3V max.	0.5V@200mA max.	
Indicator	Red LED		Green LED
Cable	ø3.3, 2C, PVC	ø3.3, 3C, PVC	
Temperature range	-10~+70°C (No freezing)		
Enclosure classification	IEC 60529 IP67		
Protection circuit (*2)	1	3, 4	
Symbol			

Order example

LN01P — AN — □

MODEL



LN01P

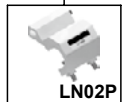

LN02P



LN03P

Blank: Lead wire
QD: Connector

SWITCH TYPE
Blank: Reed switch
AN: NPN
AP: PNP

*1. Warning: Never exceed rating (watt=voltage×amperage).

*2. 1=None / 2=Short-circuit / 3=Power source reverse polarity / 4=Surge suppression.

*3. Caution for safety

Assembling style

Cylinder type	MDM*					MRPH	
Order	LN01P	LN02P	LN03P	80	100	LN01P	
Tube I.D.	40	50	63	80	100	32	40
Mounting clamp							

Dimension

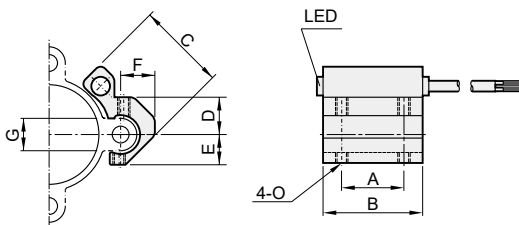

Model	A	B	C	D	E	F	G	O
LN01P	20	32	28.5	12	9.8	11	10.5	M4
LN02P	20	32	37.5	15	13.5	12	13.5	M4
LN03P	20	32	56	18	15	14	17	M4

Wiring of the QD

• 2 wire QD wiring

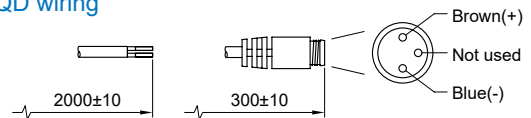

• 3 wire QD wiring

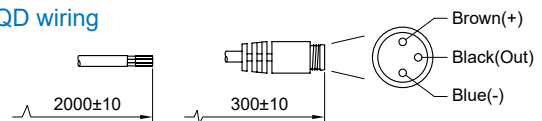



Order example

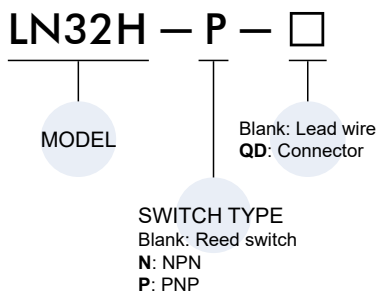

Specification

Model	LN32H	LN32H-N	LN32H-P
Wiring method	2 wire	3 wire	
Switching logic	Normally open	Solid state output, normally open	
Switch Type	Reed switch	NPN current sinking	PNP current sinking
Operating voltage	5~240V DC/AC	10~30V DC	
Switching current	100mA max.	200mA max.	
Switching rating(*1)	10W max.	3W max.	
Current consumption	—	OFF:7mA(24V) ON:17mA(24V) max.	
Voltage drop	3.5V max.	2.0V max.	
Indicator	Red LED		Yellow LED
Cable	ø3.3, 2C, PVC	ø3.3, 3C, PVC	
Temperature range	-10~+70°C (No freezing)		
Enclosure classification	IEC 60529 IP67		
Protection circuit (*2)	1	3, 4	
Symbol			

*1. Warning: Never exceed rating (watt=voltage×amperage).

*2. 1=None / 2=Short-circuit / 3=Power source reverse polarity / 4=Surge suppression.

*3. Caution for safety

Assembling style

Cylinder type	Mounting clamp
MHCB-M	

Dimension

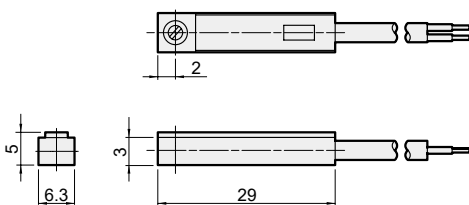

Wiring of the QD

• 2 wire QD wiring

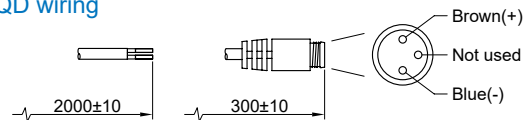

• 3 wire QD wiring

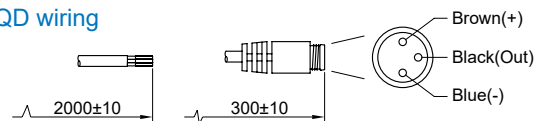



Order example

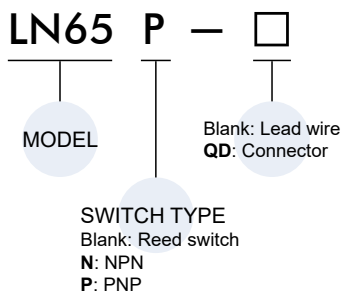

Specification

Model	LN65	LN65N	LN65P
Wiring method	2 wire	3 wire	
Switching logic	Normally open	Solid state output, normally open	
Switch Type	Reed switch	NPN current sinking	PNP current sinking
Operating voltage	5~240V DC/AC	5~30V DC	
Switching current	100mA max.	200mA max.	
Switching rating(*1)	10W max.	6W max.	
Current consumption	—	OFF:7mA(24V) ON:20mA(24V) max.	
Voltage drop	3.0V max.	0.5V@200mA max.	
Operating frequency	< 2ms	< 1ms	
Indicator	Red LED		Yellow LED
Cable	ø2.8, 2C, PUR	ø2.8, 3C, PUR	
Temperature range	-10~+70°C (No freezing)		
Enclosure classification	IP67		
Protection circuit (*2)	1	3, 4	
Symbol			

*1. Warning: Never exceed rating (watt=voltage×amperage).

*2. 1=None / 2=Short-circuit / 3=Power source reverse polarity / 4=Surge suppression.

*3. Caution for safety

Assembling style

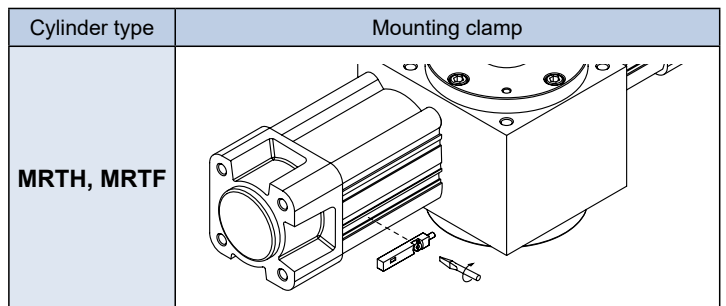

Dimension

LN65

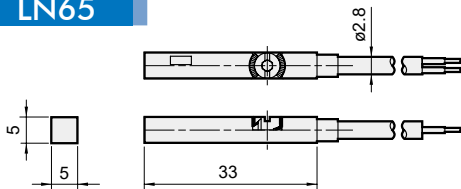

LN65N

LN65P

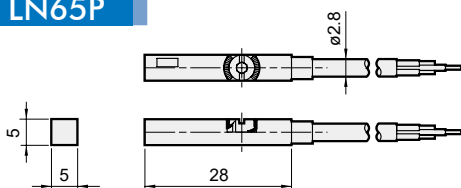

Wiring of the QD

• 2 wire QD wiring

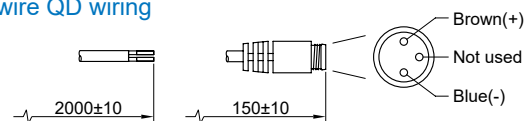

• 3 wire QD wiring

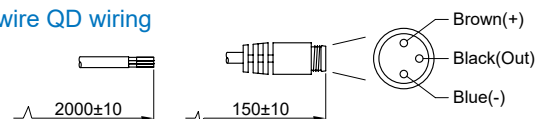



Specification

Model	M83R / M83RL	M84R / M84RL	M88R		
Female pin out					
Number of contacts	3	4	8		
Rated voltage	60V DC/AC		30V DC		
Rated current	3A		1.5		
Contact material	Gold plated brass				
Contact bearer material	PA				
Housing material	PP		PA		
Housing color	Black				
Cable material	ø4.5 PVC	ø4.5 PUR	ø4.5 PVC	ø4.5 PUR	ø5 PVC
Cable color	Gray	Black	Gray	Black	Black
Temperature	-20°C~+80°C (No freezing)				
Cable conductor	24AWG		26AWG		
Protection class	IEC60529 IP 67				

Order example

M83 R — PVC — □

Model	Connector	Cable material	Cable length
M83	M8, 3 Pin R: Straight cable socket RL: Angle cable socket	PVC: ø4.5 PVC cable PUR: ø4.5 PUR cable	Blank: 2000 mm 5M: 5000 mm
M84	M8, 4 Pin		
M88	M8, 8 Pin	PVC: ø5 PVC cable	0.45M: 450 mm

Dimension

- Straight cable socket (R)

M83/M84

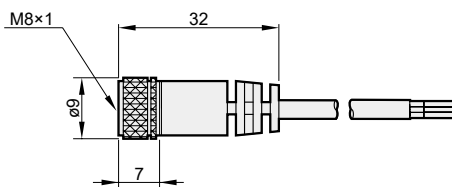

- Angle cable socket (RL)

M83/M84

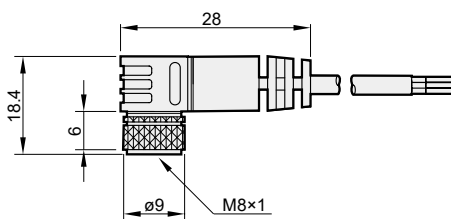

M88

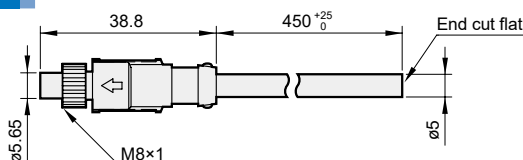

M83R-F series



CABLE WITH CONNECTOR / M8 (MALE) – M8 (FEMALE)

mindman



Specification

Model	M83R-F	
Male / Female pin out		
Number of contacts	3	3
Rated voltage	125V DC/AC	
Rated current	3A	
Contact material	Brass (Au plating)	
Contact bearer material	PVC	
Housing color	Gray	
Cable material	ø3.5, PVC	
Cable color	Gray	
Temperature	-20°C~+60°C (No freezing)	
Cable conductor	0.25mm ² / 24AWG	
Protection class of contact	IP 67	

Order example

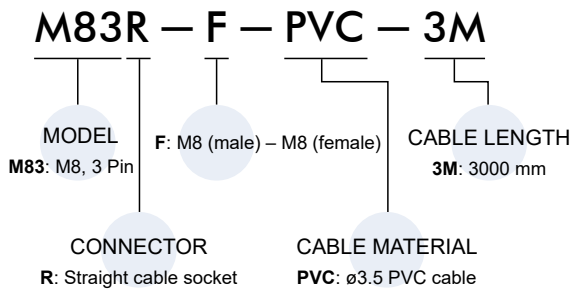

Dimension

