

MAR501 系列

空氣調理組合 (調壓器)



選用配件：MP41

符號

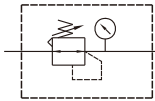

規格

型號	MAR501	
配管口徑代號	20A	25A
配管口徑尺寸	3/4	1
使用流體	空氣	
最高使用壓力	1.5 MPa	
耐壓力	2 MPa	
設定壓力範圍	0.05~0.85 MPa	
重覆精度	±7% F.S.	
周圍溫度	-5~+60°C (不凍結)	
附屬配件	壓力錶 (PG-20), L 型支架	
重量	1460 g	

訂購代號

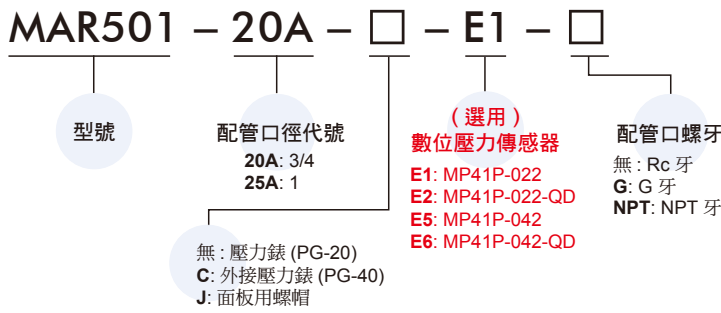

- * 選用 (C) 外接壓力表 PG-40 時, 不得與 (E*) 數位壓力傳感器 MP41 同時選用。
- * (E*) 數位壓力傳感器 MP41 規格, 請參 5-11 頁。

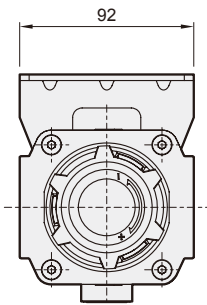

面板固定孔

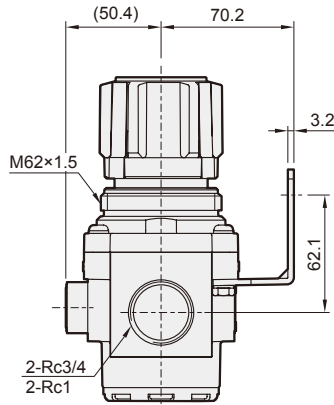
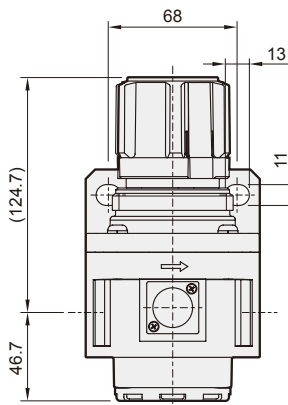
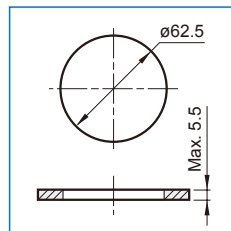

壓力特性圖

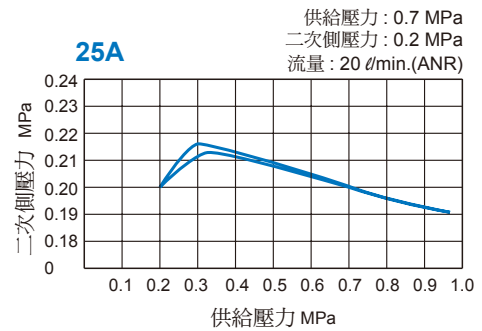
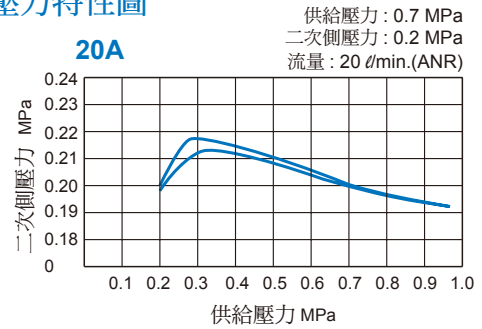

流量特性圖

