

### SDB

$\phi 20 \sim 63$  (另購 TA / TB)

$\phi 80, 100$

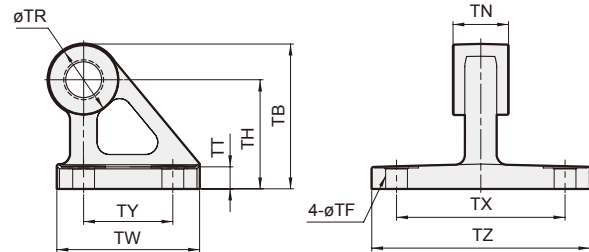
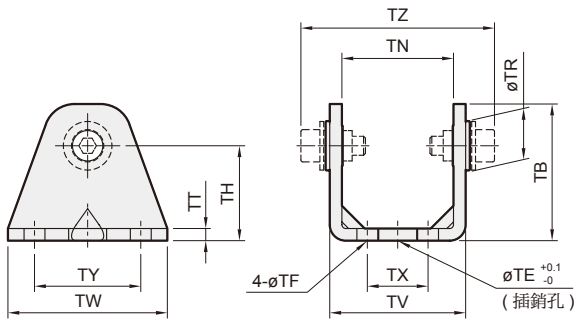

### SDB-R $\phi 20 \sim 63$

### SDB-H $\phi 20 \sim 63$

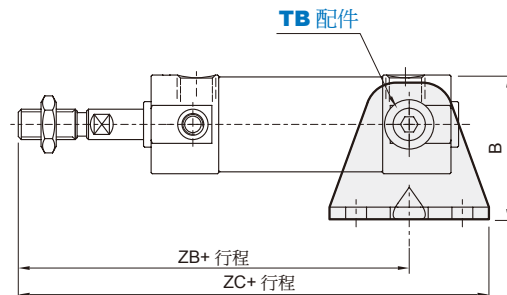
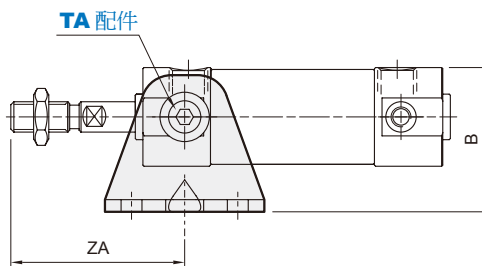

代號 內徑	B	TB	TE	TF	TH	TN	TR	TT	TV	TW	TX	TY	TZ	ZA	ZB	ZC	插銷外徑
20	38	36	10	5.5	25	29.3	14	3.2	35.8	42	16	28	51	46	93(101)	114(122)	8d9 -0.040 -0.076
25	45.5	43	10	5.5	30	33.1	16	3.2	39.8	42	20	28	58.2	51	98(106)	119(127)	10d9 -0.040 -0.076
32	54	50	10	6.6	35	40.4	18	4.5	49.4	48	22	28	71.5	51	101(108)	125(132)	12d9 -0.050 -0.093
40	63.5	58	10	6.6	40	49.2	22	4.5	58.4	56	30	30	88.5	62	118(125)	146(153)	14d9 -0.050 -0.093
50	79	70	20	9	50	60.4	25	6	72.4	64	36	36	109	71	136(147)	168(179)	16d9 -0.050 -0.093
63	96	82	20	11	60	74.6	27	8	90.4	74	46	46	131	71	136(147)	173(184)	18d9 -0.050 -0.093
80	-	73	-	11	55	28	36	11	-	72	85	45	110	-	-	-	18d9 -0.050 -0.093
100	-	90	-	13.5	65	32	50	12	-	93	100	60	130	-	-	-	22d9 -0.065 -0.117

( ): 內為長行程尺寸。