

### CA

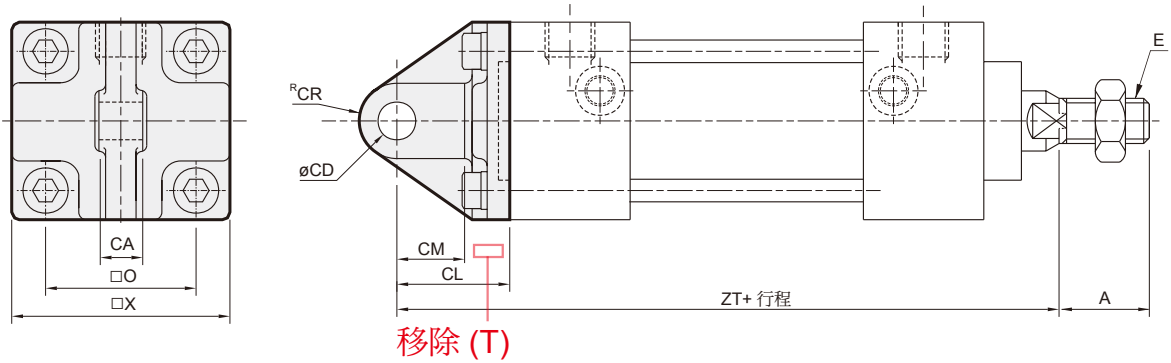

代號 內徑	A	CA	CD	CL	CM	CR	E	O	X	ZT
40	30	15 <sup>-0.1/-0.3</sup>	10 <sup>H10</sup>	30	18	10	M14×1.5	40.5	58	135
50	35	18 <sup>-0.1/-0.3</sup>	12 <sup>H10</sup>	35	22	12	M18×1.5	48	66	148
63	35	25 <sup>-0.1/-0.3</sup>	16 <sup>H10</sup>	40	27	16	M18×1.5	59	80	161
80	40	31.5 <sup>-0.1/-0.3</sup>	20 <sup>H10</sup>	48	30	20	M22×1.5	74	100	195
100	40	35.5 <sup>-0.1/-0.3</sup>	25 <sup>H10</sup>	58	38	25	M26×1.5	90	118	216

### CB

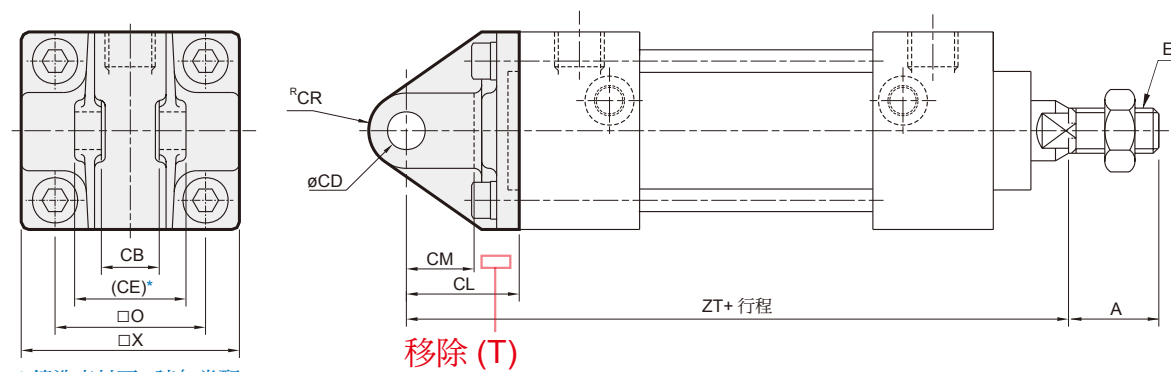

\* 鑄造素材面，請勿當配合面使用。如有需要，請洽業務。

代號 內徑	A	CB	CD	CE	CL	CM	CR	E	O	X	ZT
40	30	15 <sup>+0.3/+0.1</sup>	10 <sup>H10</sup>	29.5	30	18	10	M14×1.5	40.5	58	135
50	35	18 <sup>+0.3/+0.1</sup>	12 <sup>H10</sup>	38	35	22	12	M18×1.5	48	66	148
63	35	25 <sup>+0.3/+0.1</sup>	16 <sup>H10</sup>	49	40	27	16	M18×1.5	59	80	161
80	40	31.5 <sup>+0.3/+0.1</sup>	20 <sup>H10</sup>	59	48	30	20	M22×1.5	74	100	195
100	40	35.5 <sup>+0.3/+0.1</sup>	25 <sup>H10</sup>	64	58	38	25	M26×1.5	90	118	216

### CA

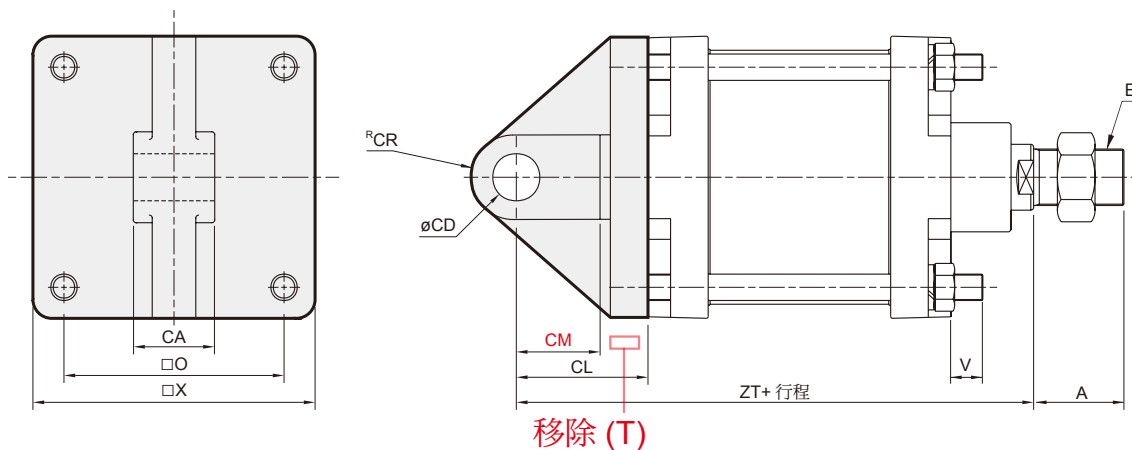

代號 內徑	A	CA	CD	CL	CM	CR	E	O	X	ZT	V
125	45	43 <sup>-0.1</sup> <sub>-0.3</sub>	25 <sup>H10</sup>	65	45	24	M30×1.5	117	150	248	20
150	50	40 <sup>-0.1</sup> <sub>-0.3</sub>	30 <sup>H10</sup>	78	53	27.5	M30×1.5	134	175	278	26
200	63	50 <sup>-0.1</sup> <sub>-0.3</sub>	40 <sup>H10</sup>	85	55	40	M45×1.5	182	226	306	12

### CB

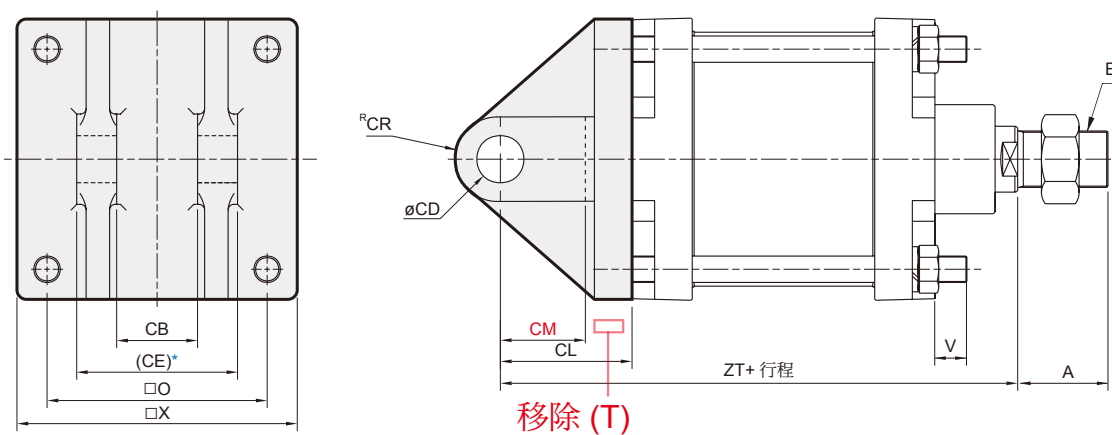

\* 鑄造素材面，請勿當配合面使用。如有需要，請洽業務。

代號 內徑	A	CB	CD	CE	CL	CM	CR	E	O	X	ZT	V
125	45	43 <sup>+0.3</sup> <sub>+0.1</sub>	25 <sup>H10</sup>	83	70	48	24	M30×1.5	117	150	253	20
150	50	40 <sup>+0.3</sup> <sub>+0.1</sub>	30 <sup>H10</sup>	90	78	53	27.5	M30×1.5	134	175	278	26
200	63	50 <sup>+0.3</sup> <sub>+0.1</sub>	40 <sup>H10</sup>	100	85	55	40	M45×1.5	182	226	306	12