

PHS-S 系列

魚眼接頭 (不銹鋼)



特點

- 屬嵌入式的軸承結構。
- 柄部本體材質屬構造用不銹鋼。
- 球體屬燒結磷青銅軸承。

訂購代號

PHS — S 20 — M20×1.5

型號

本體材質
S: 不銹鋼

規格

此螺牙尺寸
為下表 M 值

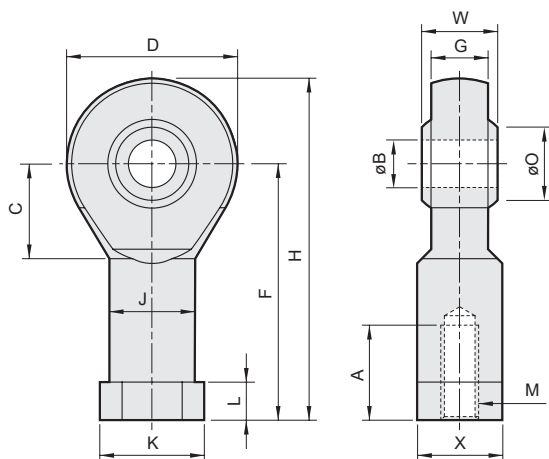

代號 型號	A	B	C	D	F	G	H	J	K	L	M	O	W	X	重量 (g)
PHS-S 4-M4×0.7	12	4	7	14	24	5.25	31	8	9.5	4	M4×0.7	7.6	7	8	12
PHS-S 5-M4×0.7 停產	10	5	10	18	27	6	36	9	11	4	M4×0.7	7.7	8	9	17
PHS-S 6-M6×1	12	6	11	20	30	6.75	40	10	13	5	M6×1.0	8.9	9	11	27
PHS-S 8-M8×1.25	16	8	13	24	36	9	48	12.5	16	5	M8×1.25	10.4	12	14	46
PHS-S 10-M10×1.25	20	10	15	28	43	10.5	57	15	19	6.5	M10×1.25	12.9	14	17	77
PHS-S 12-M12×1.25	22	12	17	32	50	12	66	17.5	22	6.5	M12×1.25	15.4	16	19	116
PHS-S 16-M16×1.5	28	16	23	42	64	15	85	22	27	8	M16×1.5	19.3	21	22	203
PHS-S 20-M20×1.5	33	20	27	50	77	18	102	27.5	34	10	M20×1.5	24.3	25	30	376