

### MHPD / MHPD-Z

#### Standard stroke (Short stroke)

Type	Working stroke			
	5	10	15	20
1T	50~75	50~125	50~150	75~200
3T	50	50~100	75~150	150~200
5T	50~75	50~150	75~200	150~200
8T	50~75	50~150	75~200	150~200
10T	50	50~125	50~200	125~200
1T-Z	50~75	50~125	50~150	50~200
3T-Z	50	50~100	75~150	100~200
5T-Z	50~75	50~150	50~200	125~200
8T-Z	50~75	50~150	50~200	100~200
10T-Z	50	50~125	50~200	75~200

#### Working stroke

Type	W			
	5	10	15	20
1T	108	146	184	222
3T	126	187	248	309
5T	135	199	263	327
8T	150	214	278	342
10T	148	212	276	340

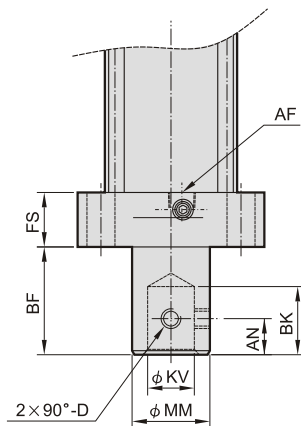

Female thread

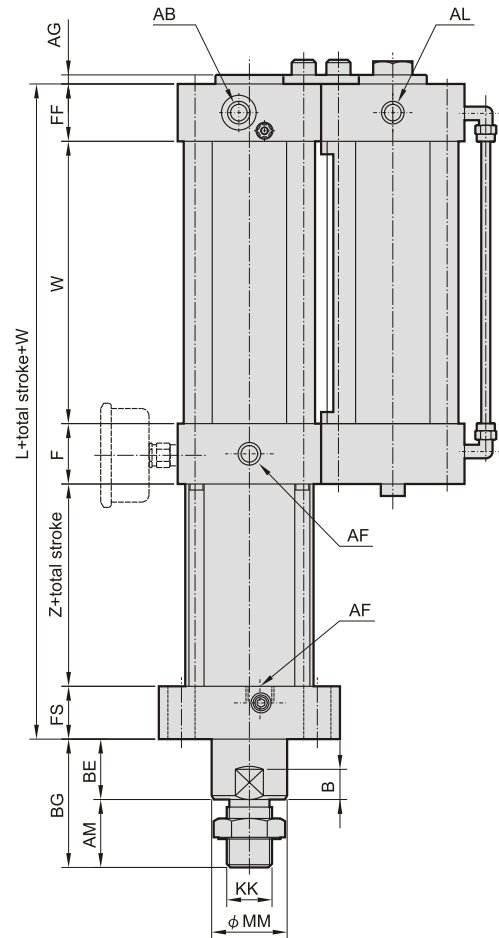
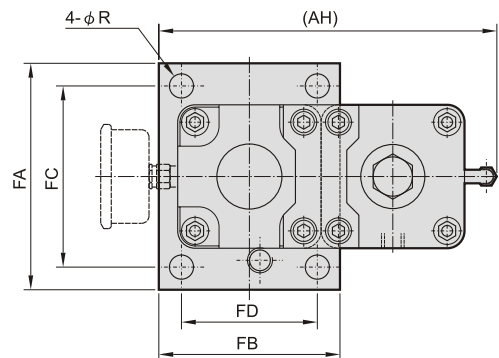
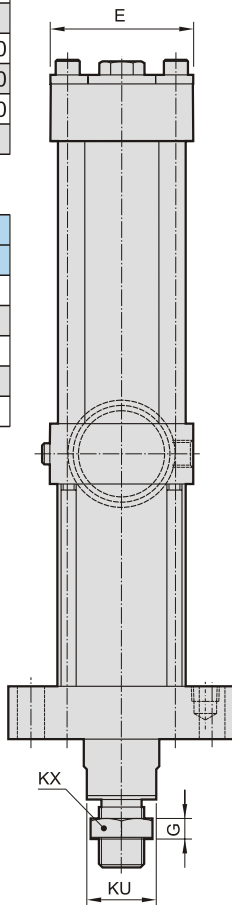

Code Type	AB	AF	AG	AH	AL	AM	AN	B	BE	BF	BG	BK	D	E	F
1T	G3/8	G3/8	5	187	G3/8	35	12	12	25	40	60	28	M6×1.0	75	40
3T	G3/8	G3/8	6	227	G3/8	45	15	20	40	50	85	35	M6×1.0	95	40
5T	G1/2	G1/2	6	262	G1/2	60	20	20	40	60	100	40	M10×1.5	115	40
8T	G1/2	G1/2	6	315	G1/2	70	25	20	50	70	120	60	M10×1.5	140	45
10T	G3/4	G3/4	6	381	G3/4	80	30	27	60	85	140	50	M10×1.5	174	55

Code Type	FA	FB	FC	FD	FF	FS	G	KK	KU	KV	KX	L	MM	R	Z
1T	130	100	100	70	32	35	11	M22×1.5	27	16	32	167	30	11	60
3T	150	120	120	90	38	35	13	M30×1.5	36	20	41	187	40	16	74
5T	185	130	155	100	40	45	15	M40×2.0	46	25	57	199	50	17	74
8T	230	160	190	120	45	45	15	M48×2.0	55	30	65	218	60	22	83
10T	270	190	220	140	55	50	20	M56×2.0	65	40	80	243	70	26	83

### MHPD / MHPD-Z

#### Standard stroke (Long stroke)

Type	Working stroke		
	5	10	15
1T	80~125	130~200	155~200
3T	55~100	105~200	155~200
5T	80~125	155~200	-
8T	80~100	155~200	-
10T	75~100	130~200	-
1T-Z	80~125	130~200	155~200
3T-Z	55~100	105~200	155~200
5T-Z	80~125	155~200	-
8T-Z	80~100	155~200	-
10T-Z	55~100	130~200	-

Type	W		
	5	10	15
1T	108	146	184
3T	126	187	248
5T	135	199	263
8T	150	214	278
10T	148	212	276

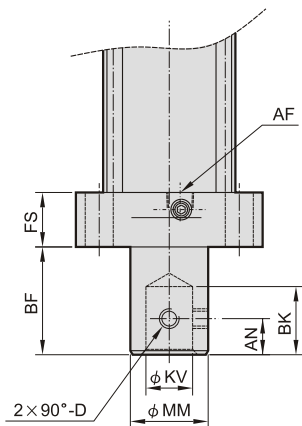

Female thread

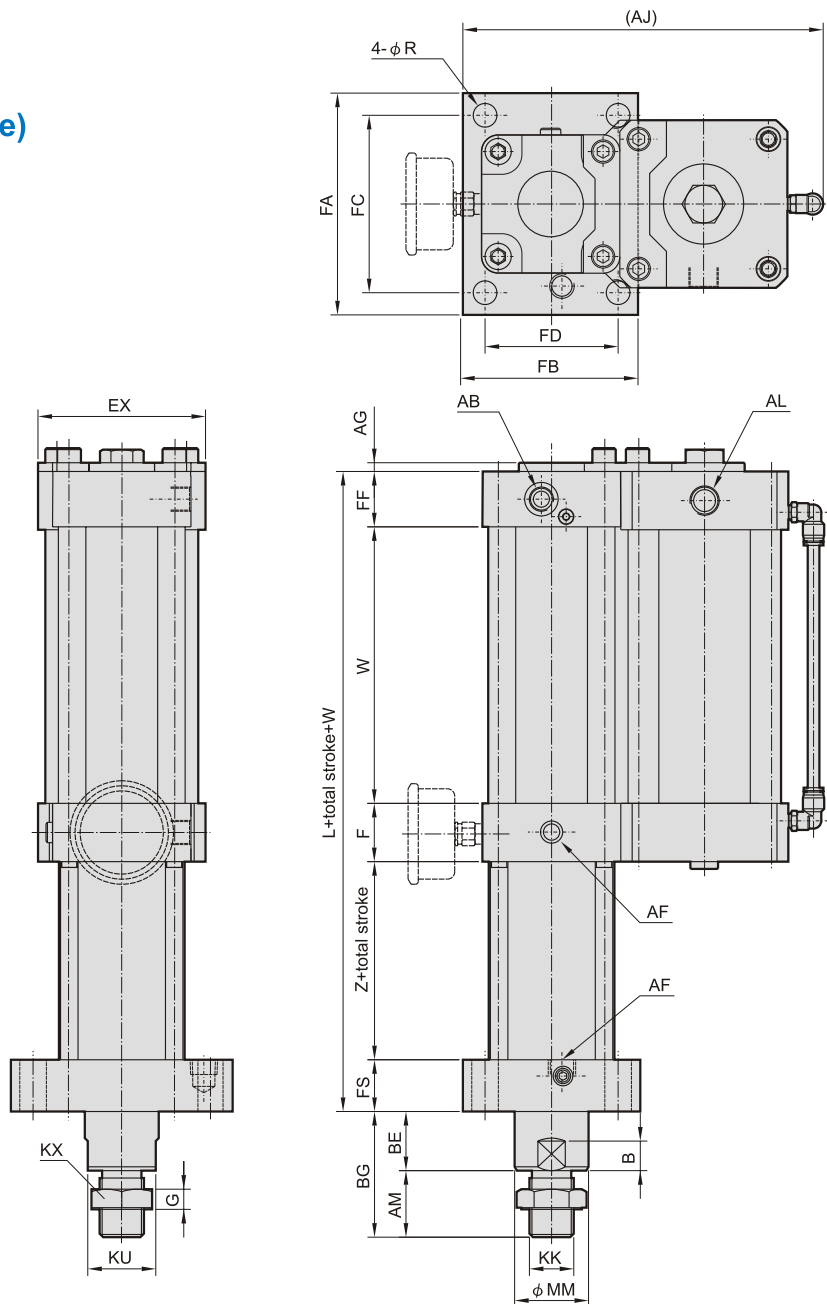

Code Type	AB	AF	AG	AJ	AL	AM	AN	B	BE	BF	BG	BK	D	EX	F
1T	G3/8	G3/8	5	207	G3/8	35	12	12	25	40	60	28	M6×1.0	95	40
3T	G3/8	G3/8	6	247	G3/8	45	15	20	40	50	85	35	M6×1.0	115	40
5T	G1/2	G1/2	6	287	G1/2	60	20	20	40	60	100	40	M10×1.5	140	40
8T	G1/2	G1/2	6	341	G1/2	70	25	20	50	70	120	60	M10×1.5	174	45
10T	G3/4	G3/4	6	411	G3/4	80	30	27	60	85	140	50	M10×1.5	204	55

Code Type	FA	FB	FC	FD	FF	FS	G	KK	KU	KV	KX	L	MM	R	Z
1T	130	100	100	70	32	35	11	M22×1.5	27	16	32	167	30	11	60
3T	150	120	120	90	38	35	13	M30×1.5	36	20	41	187	40	16	74
5T	185	130	155	100	40	45	15	M40×2.0	46	25	57	199	50	17	74
8T	230	160	190	120	45	45	15	M48×2.0	55	30	65	218	60	22	83
10T	270	190	220	140	55	50	20	M56×2.0	65	40	80	243	70	26	83