

METFB-32 Dimensions

SLIDER ELECTRIC CYLINDER (WITHOUT MOTOR)



Rotary Actuator

Clamp Cylinder

Gripper

Electric Actuator

Auxiliary Equipment

Hydraulic Cylinder

N

BW

Without guide • Motor top side

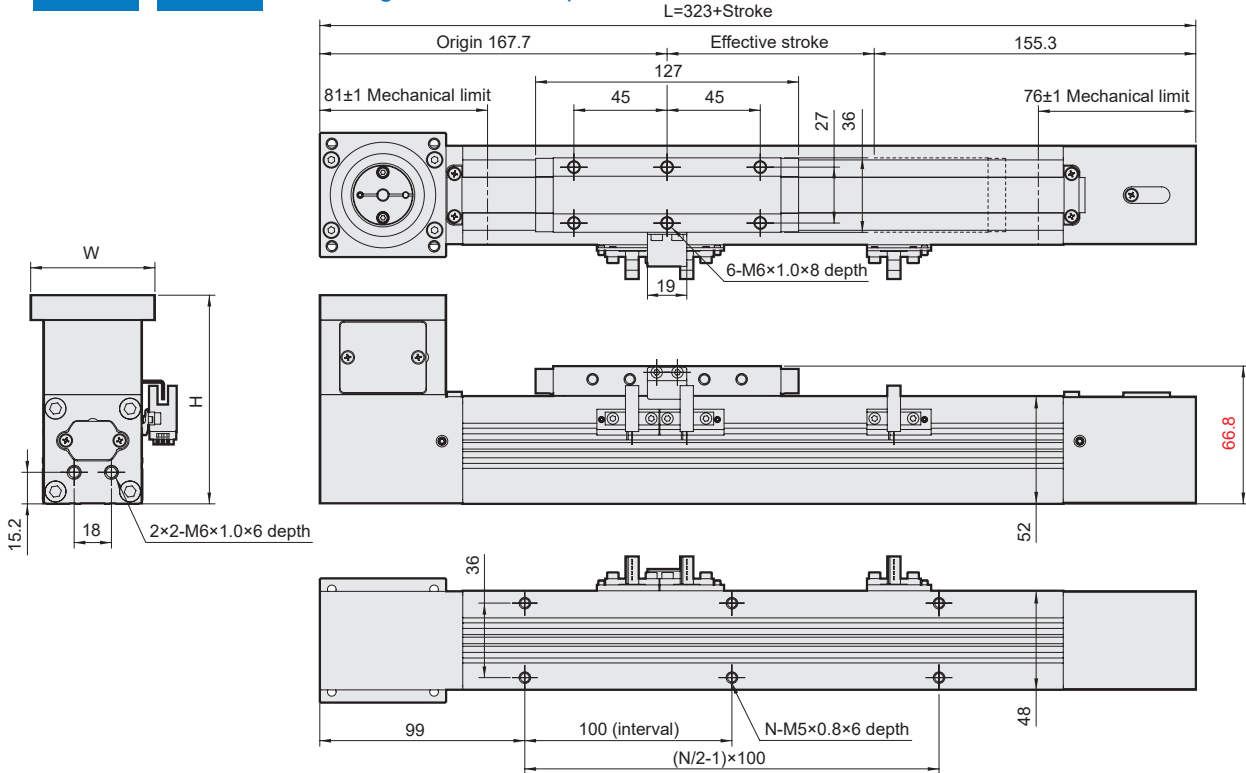

GL

BW

Guide left side • Motor top side

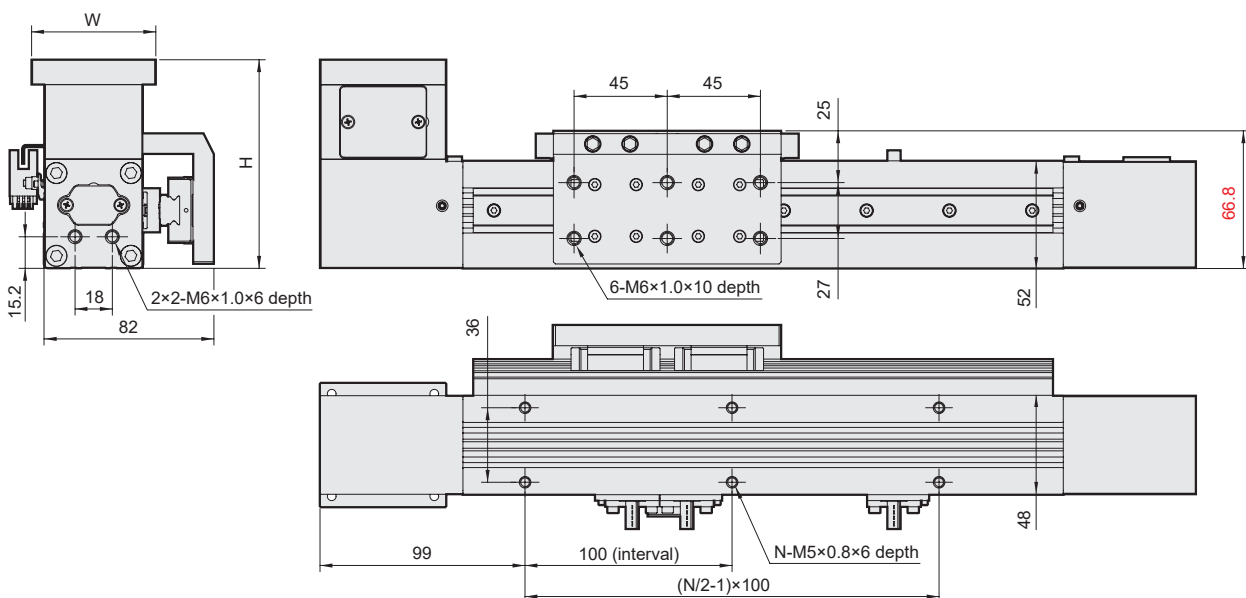

Unit: mm

Stroke Code	100	200	300	400	500	600	700	800	900	1000	1100	1200	1300	1400	1500	1600	1700	1800	1900	2000
L	423	523	623	723	823	923	1023	1123	1223	1323	1423	1523	1623	1723	1823	1923	2023	2123	2223	2323
N	6	8	10	12	14	16	18	20	22	24	26	28	30	32	34	36	38	40	42	44

Stroke Code	Servo	Step
W	60	47.6
H	100.8	94.8

METFB-32 Dimensions

SLIDER ELECTRIC CYLINDER (WITHOUT MOTOR)



N **BM** Without guide • Motor down side

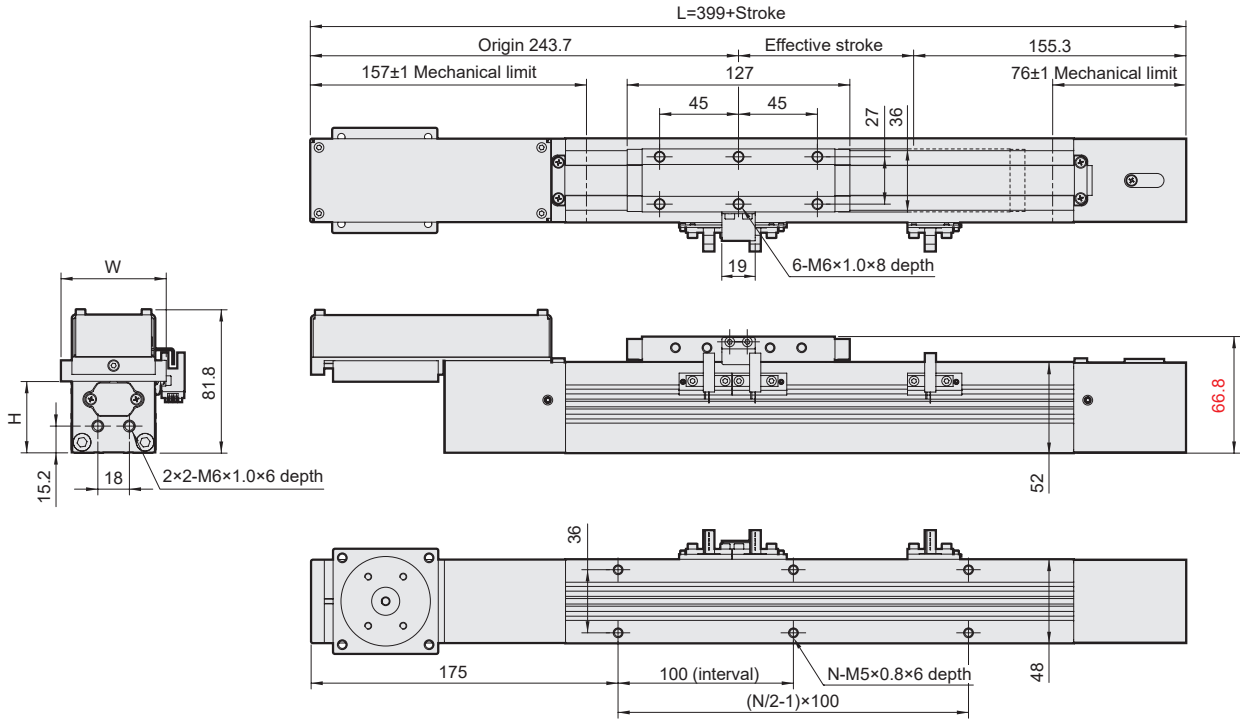

GL **BM** Guide left side • Motor down side

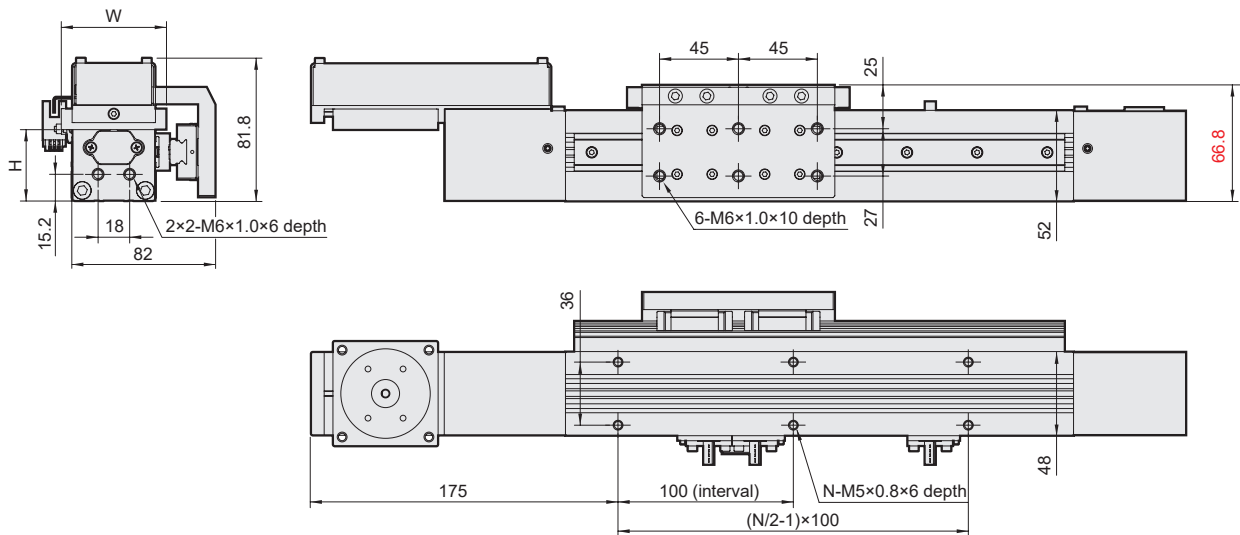

Unit: mm

Stroke Code	100	200	300	400	500	600	700	800	900	1000	1100	1200	1300	1400	1500	1600	1700	1800	1900	2000
L	499	599	699	799	899	999	1099	1199	1299	1399	1499	1599	1699	1799	1899	1999	2099	2199	2299	2399
N	6	8	10	12	14	16	18	20	22	24	26	28	30	32	34	36	38	40	42	44

Stroke Code	Servo	Step
W	60	47.6
H	40.8	42.8