

# MAR402 系列

空氣調理組合 (調壓器)



## 規格

型號	MAR402		
配管口徑代號	10A	15A	20A
配管口徑尺寸	3/8	1/2	3/4
使用流體	空氣		
最高使用壓力	1 MPa		
耐壓力	1.5 MPa		
設定壓力範圍	0.05~0.85 MPa		
周圍溫度	-5~+60°C (不凍結)		
附屬配件	壓力錶, L 型支架		
重量	974 g		

## 符號

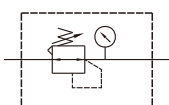

## 訂購代號

MAR402 - 15A - □

型號

配管口徑代號

配管口螺牙

10A: 3/8  
15A: 1/2  
20A: 3/4

無: Rc 牙  
G: G 牙  
NPT: NPT 牙

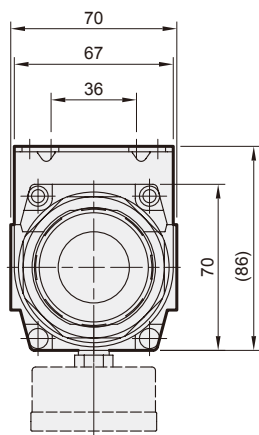

## 面板固定孔

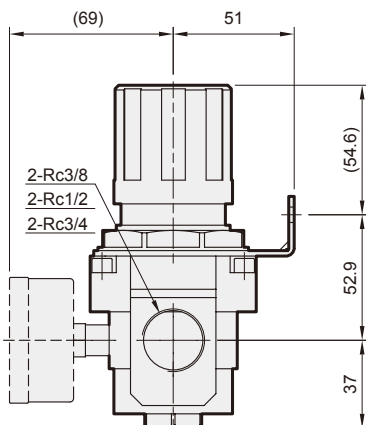
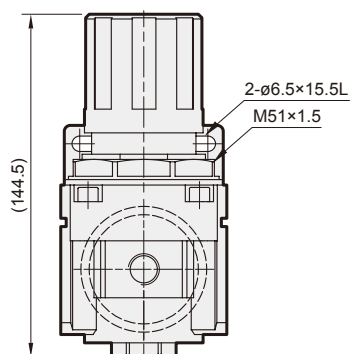
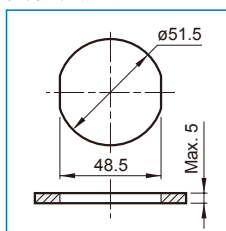

## 流量特性圖

10A, 15A, 20A 一次側壓力 0.7 MPa

