



### 標準行程表

氣缸內徑	標準行程 (mm)	長行程 (mm)	最大行程 (mm)
ø20	25,50,75,100,125,150,200	201~350	1200
ø25	25,50,75,100,125,150,200,250,300	301~400	
ø32		301~450	
ø40		301~800	
ø50		301~1200	500
ø63	301~500		
ø80	301~500		
ø100	301~500		

\* 中間行程亦可承製，請洽業務人員。

### 規格

型號	MCCG								
作動方式	複動型								
氣缸內徑 (mm)	20	25	32	40	50	63	80	100	
配管口徑尺寸	Rc1/8				Rc1/4		Rc3/8	Rc1/2	
使用流體	空氣								
最大使用壓力	1 MPa								
最小使用壓力	0.05 MPa								
耐壓力	1.5 MPa								
給油	不需給油								
周圍溫度	-5~+60°C (不凍結)								
使用速度範圍	50~500 mm/sec								
最大容許動能 (焦耳) J	墊片緩衝	0.07	0.10	0.17	0.3	0.5	0.85	1.48	2.48
	可調緩衝	0.09	0.14	0.23	0.45	0.85	1.23	2.95	4.18
傳感器	RCM (規格請參 8-16 頁)								
傳感器束帶	BMG20	BMG25	BMG32	BMG40	BMG50	BMG63	BMG80	BMG100	

\* 產品注意事項 (安裝前閱讀)，請參 3-2 頁。

### 氣缸 / 訂購代號

MCCG - 11 - 40 - 100M - A - □

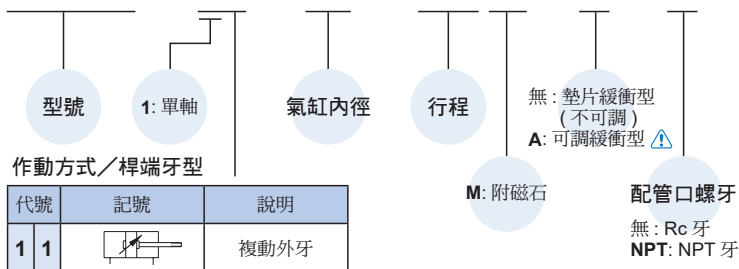

\* 特殊規格訂購請參 0-7 頁。

\* G 牙亦可承製，請洽業務人員。

### 注意

適用 (A) 可調緩衝型

- 調節緩衝時，請將針閥鎖緊，再緩慢旋開到適當緩衝狀態 (轉動需在 2.5 圈內)。
- 過度鬆開針閥，會使緩衝失效，並減短氣缸壽命。

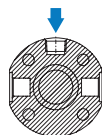
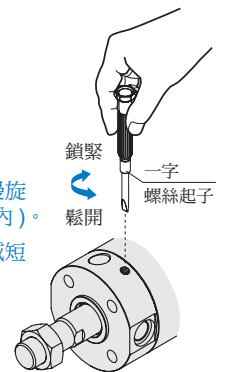

### ■ 安裝配件 / 訂購代號

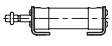
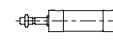
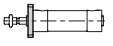
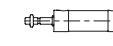
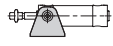
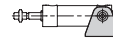

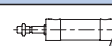
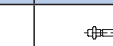
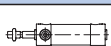
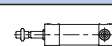
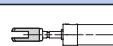
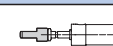
配件						
代號	LB (安裝需購買 2 個)	CB	FAC	FBC	SDB-R <sup>*1</sup> (含 TA)	SDB-H <sup>*1</sup> (含 TB)
安裝示意 內徑						
ø20	LB-C1-20	CB-C1-20	FAC-C1-20		SDB-C1-20	
ø25	LB-C1-25	CB-C1-25	FAC-C1-25		SDB-C1-25	
ø32	LB-C1-32	CB-C1-32	FAC-C1-32		SDB-C1-32	
ø40	LB-C1-40	CB-C1-40	FAC-C1-40		SDB-C1-40	
ø50	LB-C1-50	CB-C1-50	FAC-C1-50		SDB-C1-50	
ø63	LB-C1-63	CB-C1-63	FAC-C1-63		SDB-C1-63	
ø80	LB-C1-80	CB-C1-80	FAC-C1-80		-	
ø100	LB-C1-100	CB-C1-100	FAC-C1-100		-	

配件				接頭		
代號	CB+SDB+PIN <sup>*1</sup> (含插銷)	CB+SDB+PIN <sup>*1,*2</sup> (含插銷)	TA (前耳軸)	TB (後耳軸)	Y	I
安裝示意 內徑						
ø20	CB+SDB+PIN-C1-20	-	TA-C1-20		Y-C1-20	I-C1-20
ø25	CB+SDB+PIN-C1-25	-	TA-C1-25		Y-C1-25	I-C1-25
ø32	CB+SDB+PIN-C1-32	-	TA-C1-32			
ø40	CB+SDB+PIN-C1-40	-	TA-C1-40		Y-C1-40	I-C1-40
ø50	CB+SDB+PIN-C1-50	-	TA-C1-50		Y-C1-50	I-C1-50
ø63	CB+SDB+PIN-C1-63	-	TA-C1-63			
ø80	-	CB+SDB+PIN-C1-80	-		Y-C1-80	I-C1-80
ø100	-	CB+SDB+PIN-C1-100	-		Y-C1-100	I-C1-100

1. 配件組裝程序請參 3-90 頁。
2. SDB 配件 (訂購代號 SDB-C1-80 / 100)。

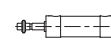
### ■ 插銷 / 訂購代號

桿前螺帽	
代號	NUT
安裝示意 內徑	
ø20	NUT-M8x1.25x5Hx13B
ø25	NUT-M10x1.25x6Hx17B
ø32	
ø40	NUT-M14x1.5x8Hx22B
ø50	NUT-M18x1.5x11Hx26B
ø63	
ø80	NUT-M22x1.5x13Hx32B
ø100	NUT-M26x1.5x14Hx35B

適用	Y&I 接頭	CB 配件
代號	PIN-Y-P (含扣環)	PIN-CB-P (含扣環)
圖示 內徑		
ø20	PIN-C1-20-2-P	PIN-C1-20-1-P
ø25	PIN-C1-25-2-P	PIN-C1-25-1-P
ø32		PIN-C1-32-1-P
ø40	PIN-C1-40-2-P	PIN-C1-40-1-P
ø50	PIN-C1-50-2-P	PIN-C1-50-1-P
ø63		PIN-C1-63-1-P
ø80	PIN-C1-80-1-P	
ø100	PIN-C1-100-1-P	

# MCCG / MCCN 內部構造及主要零件



## 圓型氣壓缸

### 墊片緩衝型 (不可調)

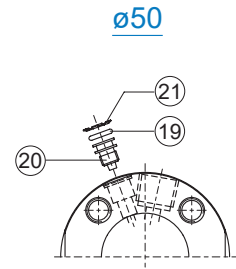
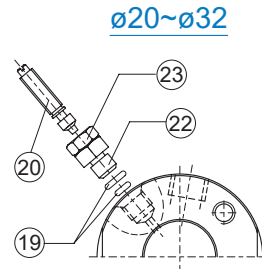
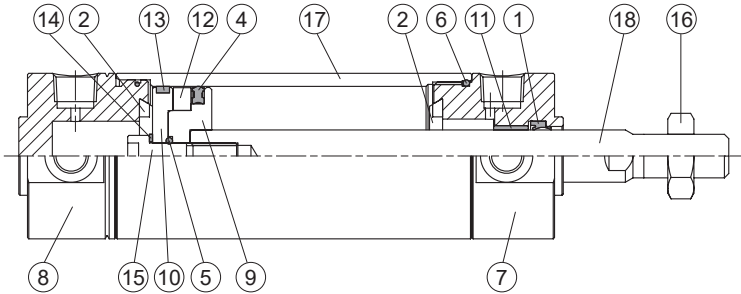

### 可調緩衝型

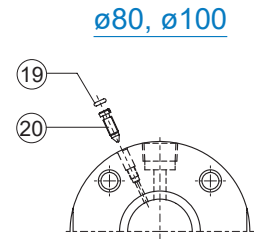
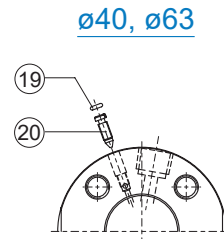
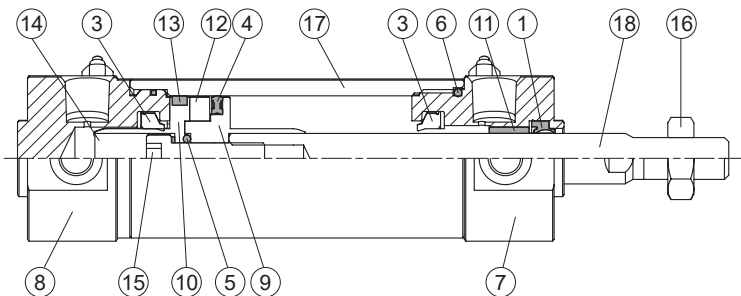

### 主要零件材質

A: 不含衝程料件, B: 修理包

No.	不可調	可調	名稱	材質	數量	A B		備註
						(內含)		
1	●	●	活塞桿密封環	NBR	1	●	●	
2	●		緩衝墊片	NBR	2	●	●	
3		●	緩衝環	NBR	2	●	●	
4	●	●	活塞密封環	NBR	1	●	●	
5	●	●	O型環	NBR	1	●	●	
6	●	●	O型環	NBR	1 or 2	●	●	ø50~100 (數量=2)
7	●	●	前蓋	鋁合金	1	●		
8	●	●	後蓋	鋁合金	1	●		
9	●	●	前活塞	鋁合金	1	●		
10	●	●	後活塞	鋁合金	1	●		
11	●	●	襯套	軸承合金	1	●		
12	●	●	磁性環	磁石材	1	◎		◎選配
			間隔環	鋁合金	1	●		適用 ø20~ø32
13	●	●	耐磨環	樹脂	1	●		
14	●	●	墊圈	碳鋼	1	●		ø20 不含此零件
15	●	●	活塞螺栓	碳鋼	1	●		
16	●	●	六角螺帽	碳鋼	1	●		
17	●	●	缸管	鋁合金	1			
18	●	●	活塞桿	碳鋼	1			ø20~25 不銹鋼
19		●	O型環	NBR	4 or 2			ø40~80 (數量=2)
20		●	針閥	不銹鋼	2			ø50: 銅合金, ø63~100: 碳鋼
21		●	針閥墊圈	碳鋼	2			僅適用 ø50
22		●	針閥固定螺帽	不銹鋼	2			僅適用 ø20~32
23		●	六角螺帽	碳鋼	2			僅適用 ø20~32

### ■ 不含衝程料件 / 訂購代號

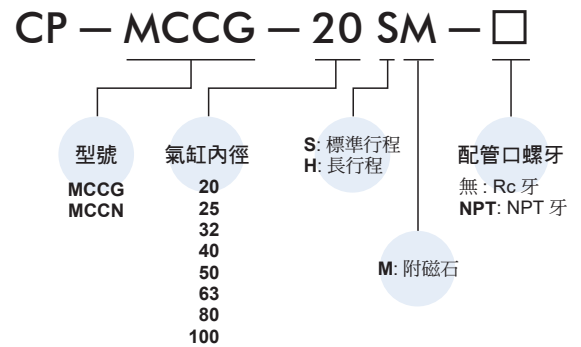

\* MCCN 僅能選用 NPT 牙。  
\* G 牙亦可承製，請洽業務人員。

### ■ 修理包 / 訂購代號

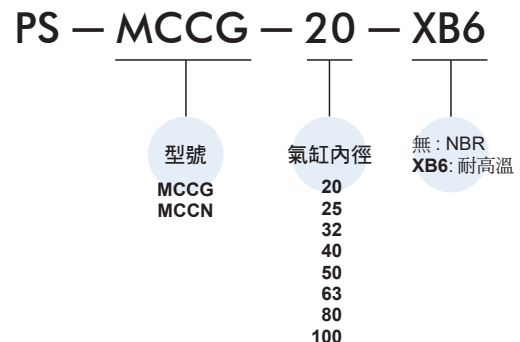

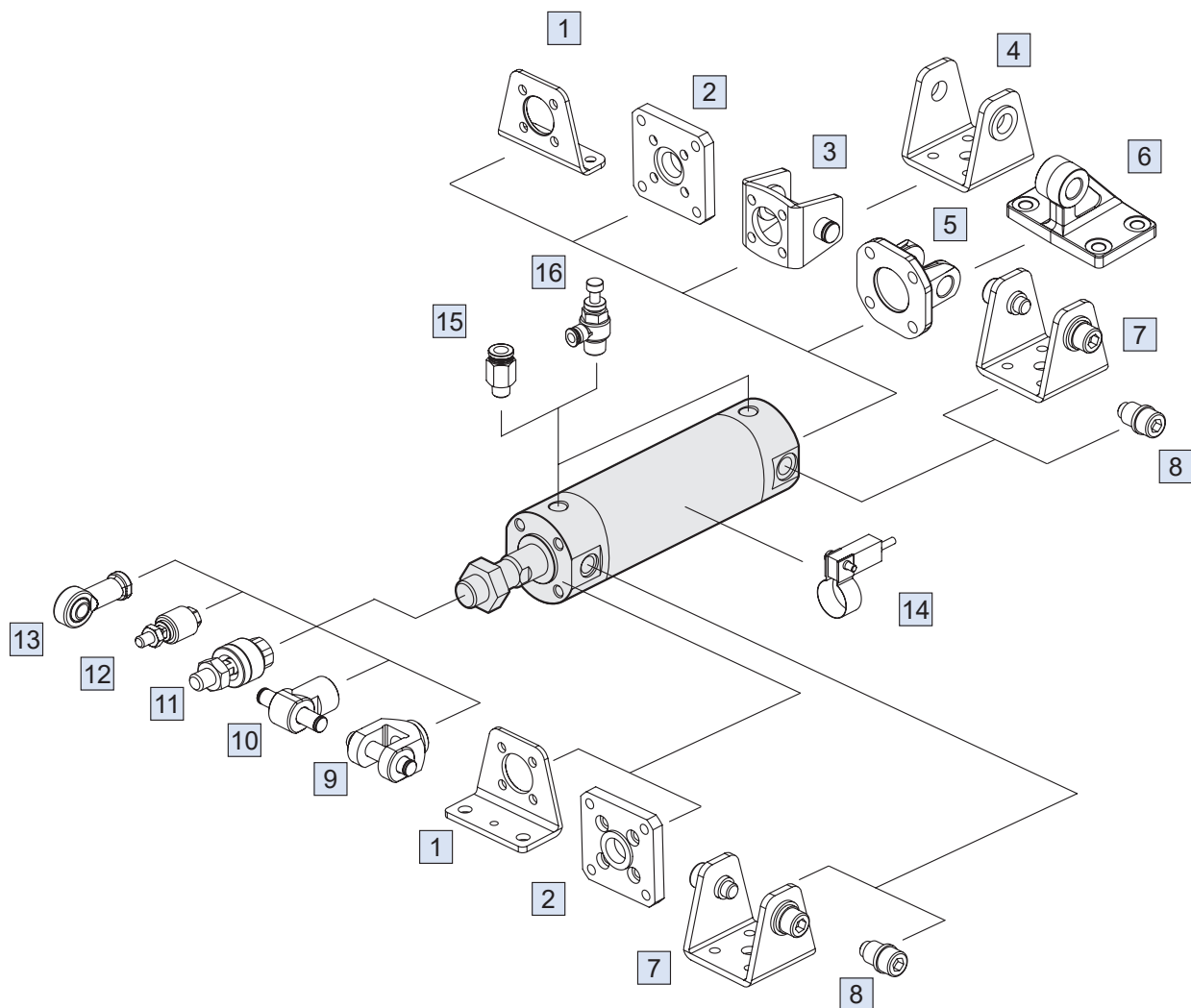

No.	安裝配件	材質	頁次
1	LB 安裝配件	碳鋼	3-87
2	FAC/FBC 安裝配件	碳鋼	3-87
3	CB+PIN 安裝配件 (*1)	碳鋼	3-88, 90, 91
4	SDB 安裝配件 (*1)	碳鋼	3-89, 90
5	CB+PIN 安裝配件 (*2)	鑄鐵 / 碳鋼	3-88, 90, 91
6	SDB 安裝配件 (*2)	鑄鐵	3-89, 90
7	SDB-R(H) 安裝配件	碳鋼	3-89
8	TA/TB 安裝配件	碳鋼	3-90

No.	安裝配件	材質	頁次
9	Y+PIN 接頭配件	碳鋼	3-91
10	I+PIN 接頭配件	碳鋼	3-91
11	MFC 浮動接頭	碳鋼	8-2
12	MFCS 浮動接頭	碳鋼	8-5
13	PHS 魚眼接頭	碳鋼	8-6
14	RCM+BMG** 傳感器 + 束帶	—	8-16
15	PC 管接頭 (PISCO)	—	8-3 (第一冊)
16	JSC 調速器 (PISCO)	—	8-21 (第一冊)

\*1. 適用內徑  $\phi 20\sim 63$

\*2. 適用內徑  $\phi 80, 100$

# MCCG 外觀尺寸 $\phi 20 \sim \phi 100$



## 圓型氣壓缸

mindman

$\phi 20, \phi 25$

$\phi 32 \sim \phi 100$

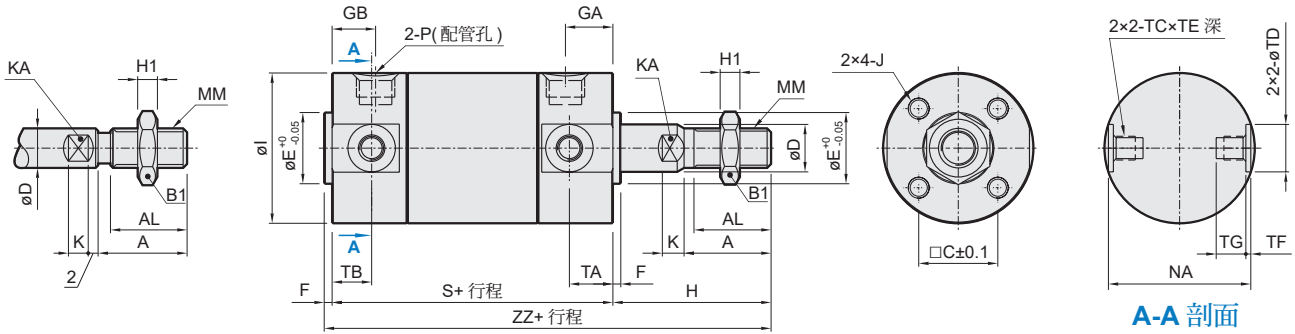

A-A 剖面

### ■ 可調緩衝型

A

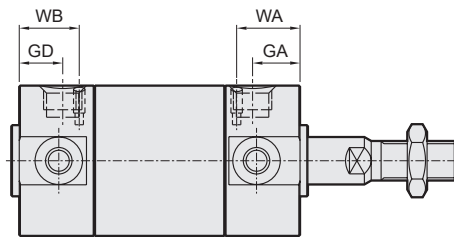

$\phi 20 \sim \phi 63$

$\phi 80, \phi 100$

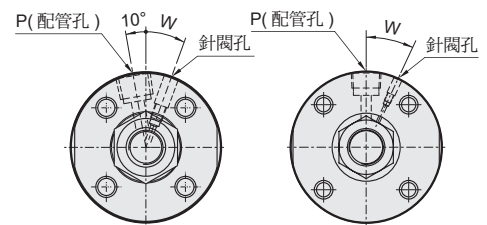

代號 內徑	標準行程 範圍	長行程 範圍	A	AL	B1	C	D	E	F	GA	GB	GD	H	H1	I	J	K	KA
20	~200	201~350	18	15.5	13	14	8	12	2	12	12 (12)	12 (12)	35	5	26	M4×0.7×7 深	4	6
25	~300	301~400	22	19.5	17	16.5	10	14	2	12	12 (12)	12 (12)	40	6	31	M5×0.8×7.5 深	5	8
32	~300	301~450	22	19.5	17	20	12	18	2	12	11 (12)	11 (12)	40	6	38	M5×0.8×8 深	5.5	10
40	~300	301~800	30	27	22	26	16	25	2	13	12 (13)	10 (13)	50	8	47	M6×1.0×12 深	6	14
50	~300	301~1200	35	32	26	32	20	30	2	14	13 (13)	12 (14)	58	11	58	M8×1.25×16 深	7	18
63	~300	301~700	35	32	26	38	20	32	2	14	13 (13)	12 (14)	58	11	72	M10×1.5×16 深	7	18
80	~300	301~700	40	37	32	50	25	40	3	20	16 (16)	16 (16)	71	13	89	M10×1.5×22 深	10	22
100	~300	301~700	40	37	35	60	30	50	3	20	16 (16)	16 (16)	71	14	110	M12×1.75×22 深	10	26

代號 內徑	MM	NA	P	S	TA	TB	TC	TD <sub>H9</sub>	TE	TF	TG	W	WA	WB	ZZ
20	M8×1.25	24	Rc1/8	69(77)	11	11 (11)	M5×0.8	8 <sup>+0.036</sup> <sub>-0</sub>	4	0.5	5.5	40°	14	14 (14)	106 (114)
25	M10×1.25	29	Rc1/8	69(77)	11	11 (11)	M6×0.75	10 <sup>+0.036</sup> <sub>-0</sub>	5	1	6.5	40°	14	13 (13)	111 (119)
32	M10×1.25	36	Rc1/8	71(79)	11	10 (11)	M8×1.0	12 <sup>+0.043</sup> <sub>-0</sub>	5.5	1.25	7.5	30°	14	13 (13)	113 (121)
40	M14×1.5	44	Rc1/8	78(87)	12	10 (12)	M10×1.25	14 <sup>+0.043</sup> <sub>-0</sub>	6	1.25	8	20°	16	15 (16)	130 (139)
50	M18×1.5	55	Rc1/4	90(102)	13	12 (13)	M12×1.25	16 <sup>+0.043</sup> <sub>-0</sub>	7.5	2	10	20°	16	16 (16)	150 (162)
63	M18×1.5	69	Rc1/4	90(102)	13	12 (13)	M14×1.5	18 <sup>+0.043</sup> <sub>-0</sub>	11.5	3	14.5	20°	18	18 (18)	150 (162)
80	M22×1.5	86	RC3/8	108(122)	-	-	-	-	-	-	-	25°	24	20 (20)	182 (196)
100	M26×1.5	106	RC1/2	108(122)	-	-	-	-	-	-	-	25°	24	20 (20)	182 (196)

( ): 內為長行程尺寸。

### ■ 傳感器安裝

傳感器：RCM，傳感器束帶：BMG\*\*

代號 內徑	A	B	C	D	E
20	24	37.5	7	16	28
25	26.5	42.5	7	16	28
32	30.5	50.5	7	16	28
40	35	59.5	7	16	28
50	40.5	70.5	7	16	28
63	47.5	84.5	7	16	28
80	56	101.5	7	16	28
100	66.5	122.5	7	16	28

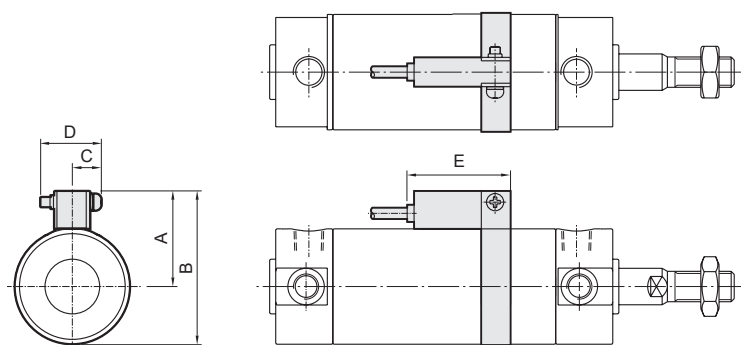

### LB

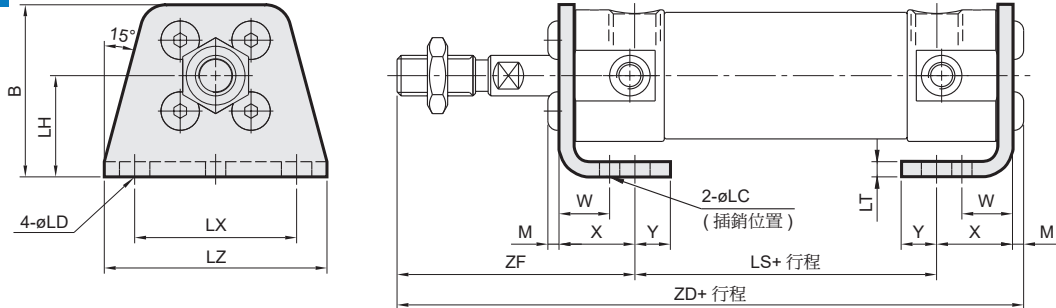

代號 內徑	B	LC	LD	LH	LS	LT	LX	LZ	M	W	X	Y	ZD	ZF
20	34	4	6	20	45 (53)	3	32	44	2.2	10	15	7	109.2 (117.2)	47
25	38.5	4	6	22	45 (53)	3	36	49	2.8	10	15	7	114.8 (122.8)	52
32	45	4	6.6	25	45 (53)	3	44	58	2.8	10	16	8	116.8 (124.8)	53
40	54.5	4	6.6	30	51 (60)	3	54	71	3.3	10	16.5	8.5	134.3 (143.3)	63.5
50	70.5	5	9	40	55 (67)	4.5	66	86	4.4	17.5	22	11	156.9 (168.9)	75.5
63	82.5	5	11	45	55 (67)	4.5	82	106	5.5	17.5	22	13	158.0 (170.0)	75.5
80	101	6	11	55	60 (74)	4.5	100	125	5.5	20	28.5	14	189.0 (203.0)	95.0
100	121	6	14	65	60 (74)	6	120	150	6.2	20	30	16	192.2 (206.2)	95.0

( ): 內為長行程尺寸。

### FAC

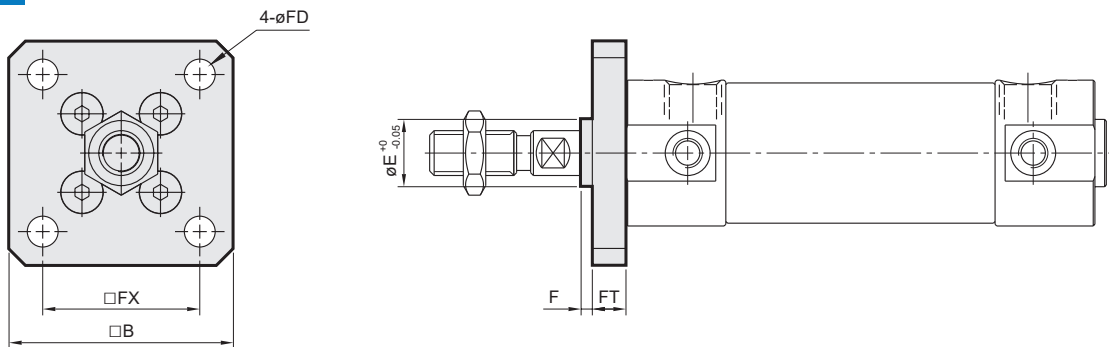

### FBC

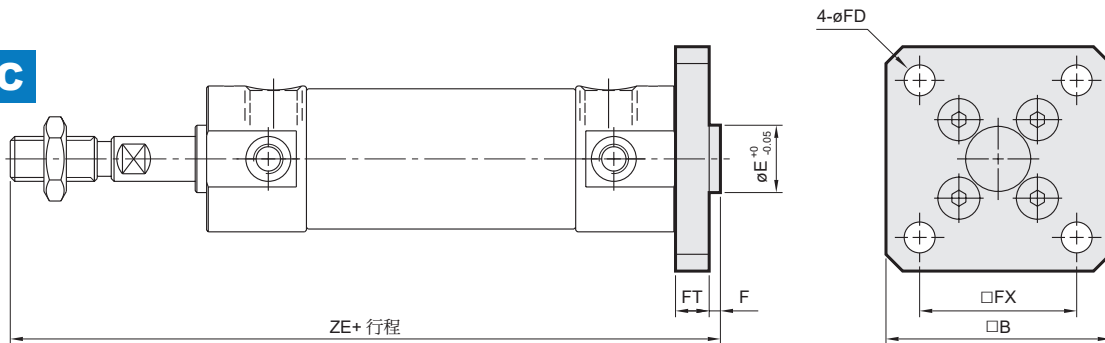

代號 內徑	B	E	F	FX	FD	FT	ZE
20	40	12	2	28	5.5	6	112 (120)
25	44	14	2	32	5.5	7	118 (126)
32	53	18	2	38	6.6	7	120 (128)
40	61	25	2	46	6.6	8	138 (147)
50	76	30	2	58	9	9	159 (171)
63	92	32	2	70	11	9	159 (171)
80	104	40	3	82	11	11	193 (207)
100	128	50	3	100	14	14	196 (210)

( ): 內為長行程尺寸。

### CB (另購 SDB + 插銷)

$\phi 20 \sim 63$

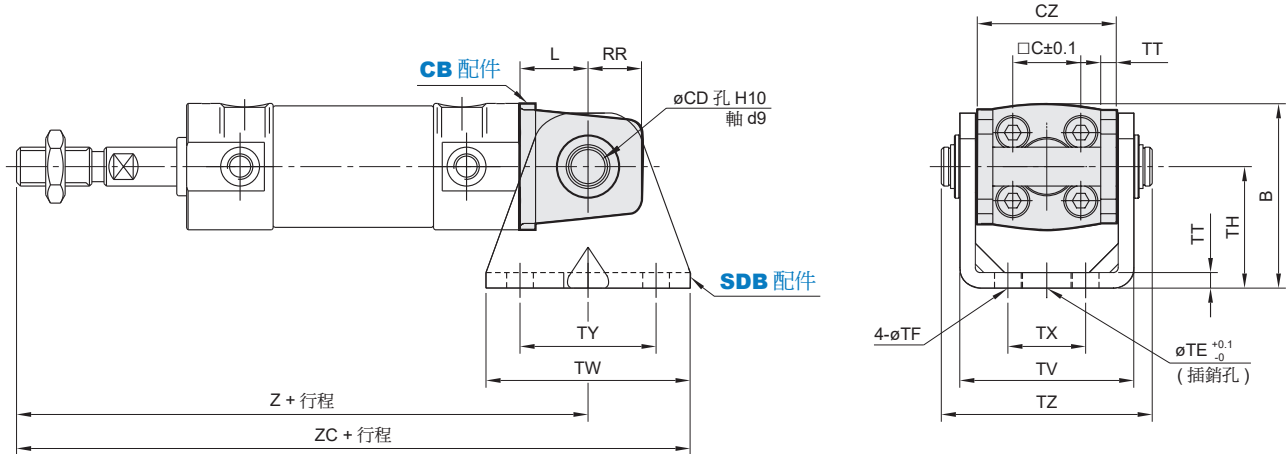

$\phi 80, 100$

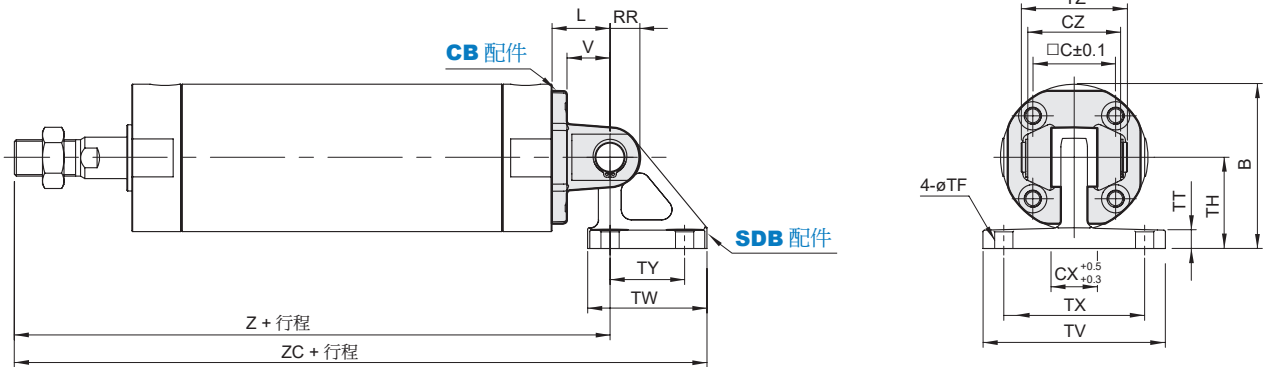

代號 內徑	B	C	CD	CX	CZ	L	RR	V	TE	TF	TH	TT	TV	TW	TX	TY	TZ	Z	ZC
20	38	14	8	-	29	14	11	-	10	5.5	25	3.2	35.8	42	16	28	43.4	118 (126)	139 (147)
25	45.5	16.5	10	-	33	16	13	-	10	5.5	30	3.2	39.8	42	20	28	48	125 (133)	146 (154)
32	54	20	12	-	40	20	15	-	10	6.6	35	4.5	49.4	48	22	28	59.4	131 (139)	155 (163)
40	63.5	26	14	-	49	22	18	-	10	6.6	40	4.5	58.4	56	30	30	71.4	150 (159)	178 (187)
50	79	32	16	-	60	25	20	-	20	9	50	6	72.4	64	36	36	86	173 (185)	205 (217)
63	96	38	18	-	74	30	22	-	20	11	60	8	90.4	74	46	46	105.4	178 (190)	215 (227)
80	99.5	50	18	28	56	35	18	26	-	11	55	11	110	72	85	45	64	214 (228)	272.5 (286.5)
100	120	60	22	32	64	43	22	32	-	13.5	65	12	130	93	100	60	72	222 (236)	298.5 (312.5)

( ) 內為長行程尺寸。

### SDB

$\phi 20 \sim 63$  (另購 TA / TB)

$\phi 80, 100$

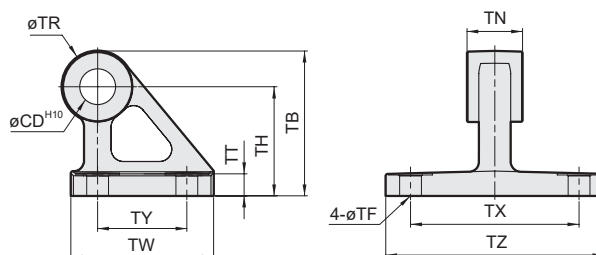
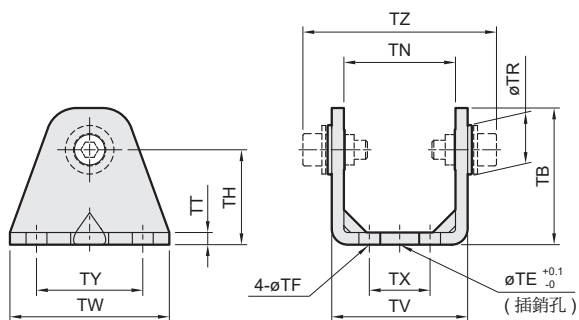

### SDB-R $\phi 20 \sim 63$

### SDB-H $\phi 20 \sim 63$

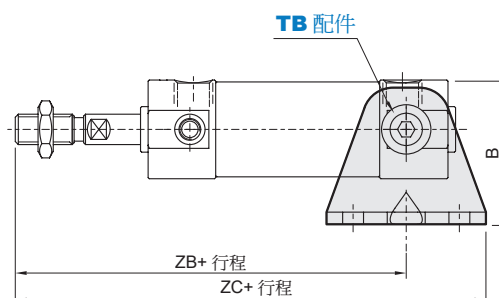
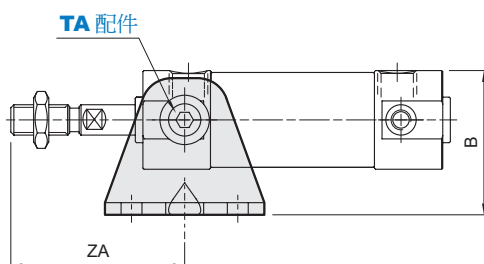

代號 內徑	B	CD	TB	TE	TF	TH	TN	TR	TT	TV	TW	TX	TY	TZ	ZA	ZB	ZC	插銷外徑
20	38	-	36	10	5.5	25	29.3	14	3.2	35.8	42	16	28	51	46	93(101)	114(122)	8d9 -0.040 -0.076
25	45.5	-	43	10	5.5	30	33.1	16	3.2	39.8	42	20	28	58.2	51	98(106)	119(127)	10d9 -0.040 -0.076
32	54	-	50	10	6.6	35	40.4	18	4.5	49.4	48	22	28	71.5	51	101(108)	125(132)	12d9 -0.050 -0.093
40	63.5	-	58	10	6.6	40	49.2	22	4.5	58.4	56	30	30	88.5	62	118(125)	146(153)	14d9 -0.050 -0.093
50	79	-	70	20	9	50	60.4	25	6	72.4	64	36	36	109	71	136(147)	168(179)	16d9 -0.050 -0.093
63	96	-	82	20	11	60	74.6	27	8	90.4	74	46	46	131	71	136(147)	173(184)	18d9 -0.050 -0.093
80	-	18	73	-	11	55	28	36	11	-	72	85	45	110	-	-	-	18d9 -0.050 -0.093
100	-	22	90	-	13.5	65	32	50	12	-	93	100	60	130	-	-	-	22d9 -0.065 -0.117

( ): 內為長行程尺寸。



### TA

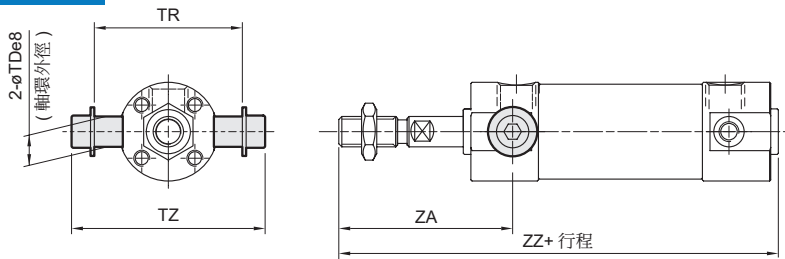

### TB

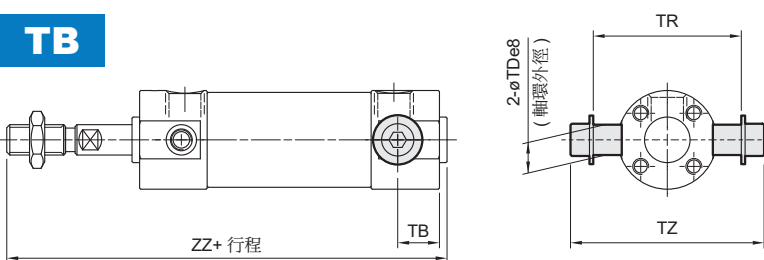

代號 內徑	TB	TDe8	TR	TZ	ZA	ZZ
20	11(11)	8 <sup>+0.025</sup> <sub>-0.047</sub>	39	51	46	106 (114)
25	11(11)	10 <sup>+0.025</sup> <sub>-0.047</sub>	43	58.2	51	111 (119)
32	10(11)	12 <sup>+0.032</sup> <sub>-0.059</sub>	53.5	71.5	51	113 (121)
40	10(12)	14 <sup>+0.032</sup> <sub>-0.059</sub>	64.5	88.5	62	130 (139)
50	12(13)	16 <sup>+0.032</sup> <sub>-0.059</sub>	80	109	71	150 (162)
63	12(13)	18 <sup>+0.032</sup> <sub>-0.059</sub>	98	131	71	150 (162)

( ): 內為長行程尺寸。

## MCCG / MCCN

### SDB-R(H) / TA / TB 安裝程序

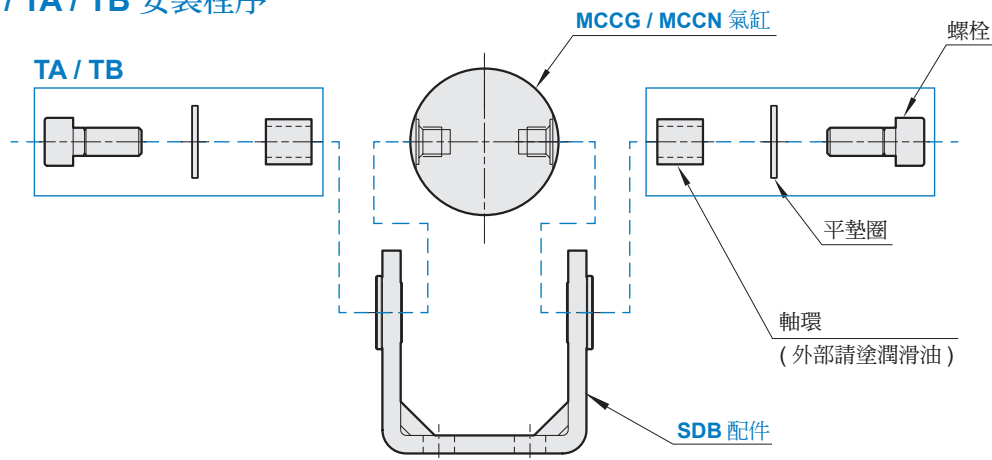

### CB+PIN+SDB 安裝程序

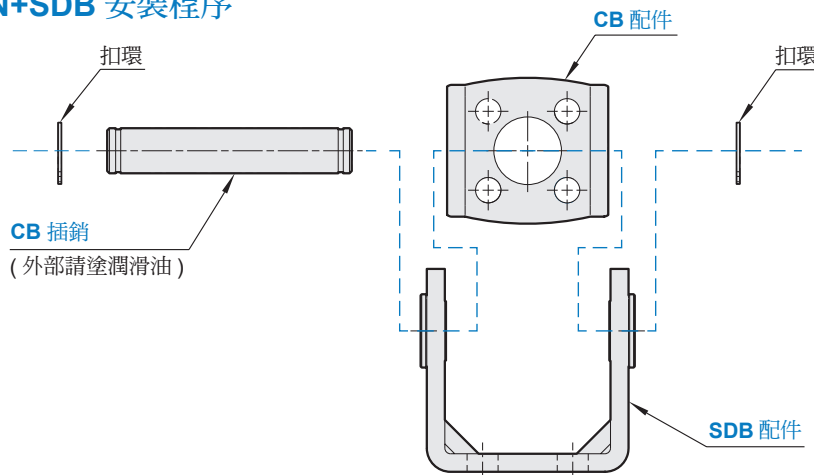

### Y 接頭

$\phi 20 \sim \phi 32$

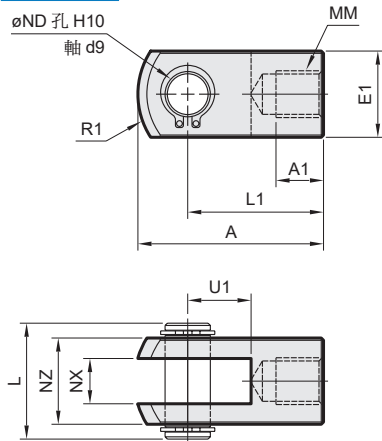

$\phi 40 \sim \phi 63$

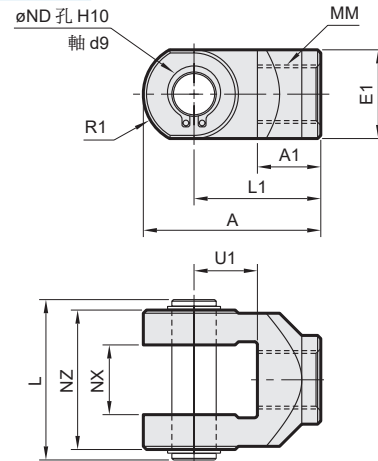

$\phi 80, \phi 100$

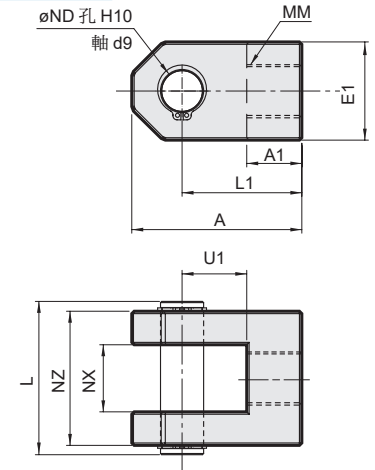

代號 內徑	A	A1	E1	L	L1	MM	R1	U1	ND	NX	NZ
20	34	8.5	16	21	25	M8×1.25	14	11.5	8	8 <sup>+0.4</sup> <sub>+0.2</sub>	15.88
25,32	41	10.5	20	25.6	30	M10×1.25	18	14	10	10 <sup>+0.4</sup> <sub>+0.2</sub>	19.05
40	42	16	20	41.6	30	M14×1.5	12	14	10	18 <sup>+0.5</sup> <sub>+0.3</sub>	36
50,63	56	20	25	50.6	40	M18×1.5	16	20	14	22 <sup>+0.5</sup> <sub>+0.3</sub>	44
80	71	23	41	64	50	M22×1.5	-	26	18	28 <sup>+0.5</sup> <sub>+0.3</sub>	56
100	79	24	47	72	55	M26×1.5	-	30	22	32 <sup>+0.5</sup> <sub>+0.3</sub>	64

### I 接頭

$\phi 20 \sim \phi 32$

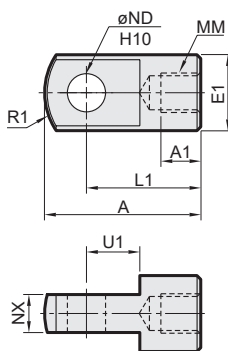

$\phi 40 \sim \phi 63$

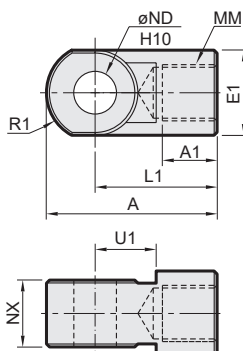

$\phi 80, \phi 100$

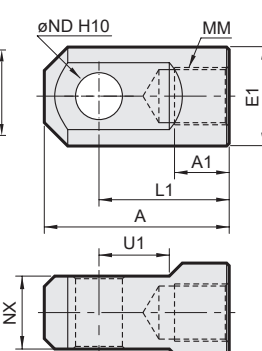

代號 內徑	A	A1	E1	L1	MM	R1	U1	ND <sub>H10</sub>	NX
20	34	8.5	16	25	M8×1.25	14	11.5	8 <sup>+0.058</sup> <sub>0</sub>	8 <sup>-0.2</sup> <sub>-0.4</sub>
25,32	41	10.5	20	30	M10×1.25	18	14	10 <sup>+0.058</sup> <sub>0</sub>	10 <sup>-0.2</sup> <sub>-0.4</sub>
40	42	14	22	30	M14×1.5	12	14	10 <sup>+0.058</sup> <sub>0</sub>	18 <sup>-0.3</sup> <sub>-0.5</sub>
50,63	56	18	28	40	M18×1.5	16	20	14 <sup>+0.070</sup> <sub>0</sub>	22 <sup>-0.3</sup> <sub>-0.5</sub>
80	71	21	38	50	M22×1.5	-	27	18 <sup>-0.070</sup> <sub>0</sub>	28 <sup>-0.3</sup> <sub>-0.5</sub>
100	79	21	45	55	M26×1.5	-	31	22 <sup>-0.084</sup> <sub>0</sub>	32 <sup>-0.3</sup> <sub>-0.5</sub>

### 插銷

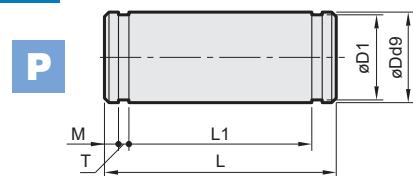

### CB 型 配件適用插銷





代號 內徑	Dd9	D1	L	L1	M	T	扣環
20	8 <sup>-0.04</sup> <sub>-0.08</sub>	7.6	43.4	38.6	1.5	0.9	STW-8
25	10 <sup>-0.04</sup> <sub>-0.08</sub>	9.6	48	42.6	1.55	1.15	STW-10
32	12 <sup>-0.05</sup> <sub>-0.09</sub>	11.5	59.4	54	1.55	1.15	STW-12
40	14 <sup>-0.05</sup> <sub>-0.09</sub>	13.4	71.4	65	2.05	1.15	STW-14
50	16 <sup>-0.05</sup> <sub>-0.09</sub>	15.2	86	79.6	2.05	1.15	STW-16
63	18 <sup>-0.05</sup> <sub>-0.09</sub>	17.0	105.4	97.8	2.45	1.35	STW-18
80	18 <sup>-0.05</sup> <sub>-0.09</sub>	17	64	56.2	2.55	1.35	STW-18
100	22 <sup>-0.06</sup> <sub>-0.11</sub>	21	72	64.2	2.55	1.35	STW-22

### Y 型 & I 型 接頭適用插銷







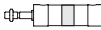



代號 內徑	Dd9	D1	L	L1	M	T	扣環
20	8 <sup>-0.04</sup> <sub>-0.08</sub>	7.6	21	16.2	1.5	0.9	STW-8
25,32	10 <sup>-0.04</sup> <sub>-0.08</sub>	9.6	25.6	20.2	1.55	1.15	STW-10
40	10 <sup>-0.04</sup> <sub>-0.08</sub>	9.6	41.6	36.2	1.55	1.15	STW-10
50,63	14 <sup>-0.05</sup> <sub>-0.09</sub>	13.4	50.6	44.2	2.05	1.15	STW-14
80	18 <sup>-0.05</sup> <sub>-0.09</sub>	17	64	56.2	2.55	1.35	STW-18
100	22 <sup>-0.06</sup> <sub>-0.11</sub>	21	72	64.2	2.55	1.35	STW-22

### 氣缸重量

單位：kg

型號	行程	基本重量		基本重量 (附磁)		行程 25 mm
		MCCG-11	MCCG-11-A	MCCG-11-M	MCCG-11-M-A	
內徑						
20	~200	0.107	0.112	0.108	0.113	0.022
	201~350	0.117	0.122	0.118	0.123	
25	~300	0.165	0.165	0.166	0.166	0.03
	301~400	0.178	0.178	0.179	0.179	
32	~300	0.233	0.237	0.234	0.238	0.043
	301~450	0.261	0.265	0.262	0.266	
40	~300	0.402	0.413	0.414	0.425	0.067
	301~800	0.44	0.451	0.452	0.463	
50	~300	0.753	0.782	0.77	0.799	0.1
	301~1200	0.838	0.867	0.855	0.884	
63	~300	1.058	1.076	1.078	1.096	0.119
	301~700	1.192	1.21	1.212	1.23	
80	~300	2.007	2.054	2.034	2.081	0.166
	301~700	2.227	2.274	2.254	2.301	
100	~300	3.015	3.094	3.05	3.129	0.234
	301~700	3.348	3.427	3.383	3.462	

### 配件重量

型號	LB	CB	FAC / FBC	SDB	TA / TB	Y	I	PIN-Y-P (含扣環)	PIN-CB-P (含扣環)	桿前螺帽
內徑										
20	0.0434	0.037	0.066	0.089	0.012	0.0352	0.0318	0.0088	0.0174	0.004
25	0.0543	0.051	0.092	0.111	0.018	0.0622	0.0598	0.0164	0.03	0.008
32	0.072	0.096	0.136	0.202	0.038				0.053	
40	0.089	0.147	0.208	0.311	0.068	0.093	0.07	0.0262	0.086	0.016
50	0.24	0.272	0.364	0.545	0.114	0.182	0.151	0.0618	0.135	0.032
63	0.352	0.488	0.521	0.725	0.176				0.2116	
80	0.45	0.57	0.786	0.933	-	0.68	0.4	0.125		0.049
100	0.814	1.075	1.542	1.719	-	0.976	0.614	0.19		0.056