

MHPD

預壓式增壓缸內孔型



MHPD-Z

預壓式增壓缸外牙型



訂購代號

MHPD - 3T × 100 - 10 - Z

型號

推力值

總行程

增壓行程

1T
3T
5T
8T
10T

50: 50mm
75: 75mm
100: 100mm
150: 150mm
200: 200mm

5: 5mm
10: 10mm
15: 15mm
20: 20mm

軸端型式

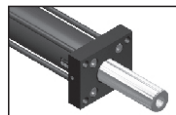

無: 內孔型

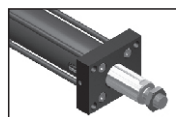

Z: 外牙型

特點

- 本壓缸結合增壓器及油壓缸，僅需使用氣壓源控制便可。
- 具有油壓高出力之特性，且不產生高溫及噪音之缺點。比油壓系統更經濟又安全及高效率。

規格

型號	MHPD
增壓推力值	1T, 3T, 5T, 8T, 10T
總行程 (mm)	50, 75, 100, 150, 200
增壓行程 (mm)	5, 10, 15, 20
使用流體	已濾清加油霧之壓縮空氣
使用壓力範圍	0.3~0.8 MPa
使用溫度範圍	-10~+60°C (不凍結)

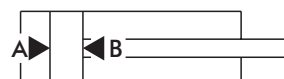

增壓缸理論出力表

單位: N

型式	1T	3T	5T	8T	10T		
內徑 (mm)	ø50	ø70	ø80	ø100	ø125		
桿徑 (mm)	ø30	ø40	ø50	ø60	ø70		
操作壓力 (MPa)	0.3	A	7,216	18,473	30,054	46,959	67,630
		B	377	778	919	1,508	2,527
	0.4	A	9,621	24,630	40,072	62,612	90,174
		B	503	1,037	1,225	2,011	3,369
	0.5	A	12,026	30,788	50,090	78,265	112,717
		B	628	1,296	1,532	2,513	4,212
	0.6	A	14,432	36,945	60,108	93,918	135,261
		B	754	1,555	1,838	3,016	5,054
	0.7	A	16,837	43,103	70,126	109,571	157,804
		B	880	1,814	2,144	3,519	5,896
	0.8	A	19,242	49,260	80,143	125,224	180,347
		B	1,005	2,073	2,450	4,021	6,739

增壓缸作動說明

1. 電磁閥 2 作動：空油轉換筒以氣壓 1 比 1 轉換油壓移動油壓缸。
2. 電磁閥 1 作動：待接近工作物時以增壓端高壓油壓對工作物作動。
3. 電磁閥 1,2 切斷：作業完成後，油壓缸復歸且增壓端回復原始位置。

增壓缸使用注意事項

- 增壓器之安裝必須保持注油口向上。
- 使用油壓作動油。
- 運轉前增壓軸心及油缸軸心需縮回。
- 增壓器之作動頻率必須低於每分鐘 20 次。

1. 預先移動行程

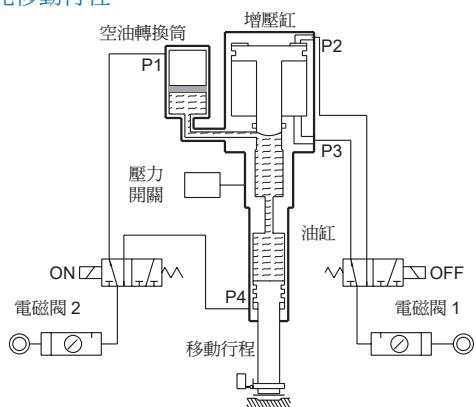

2. 加壓行程

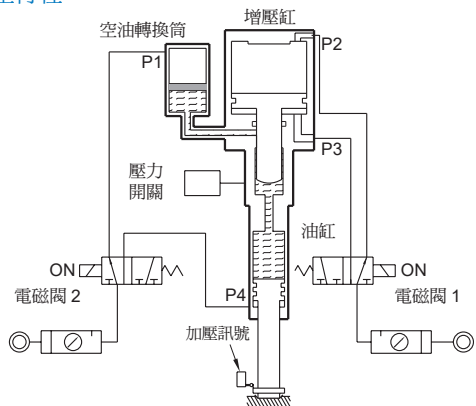

3. 復歸行程

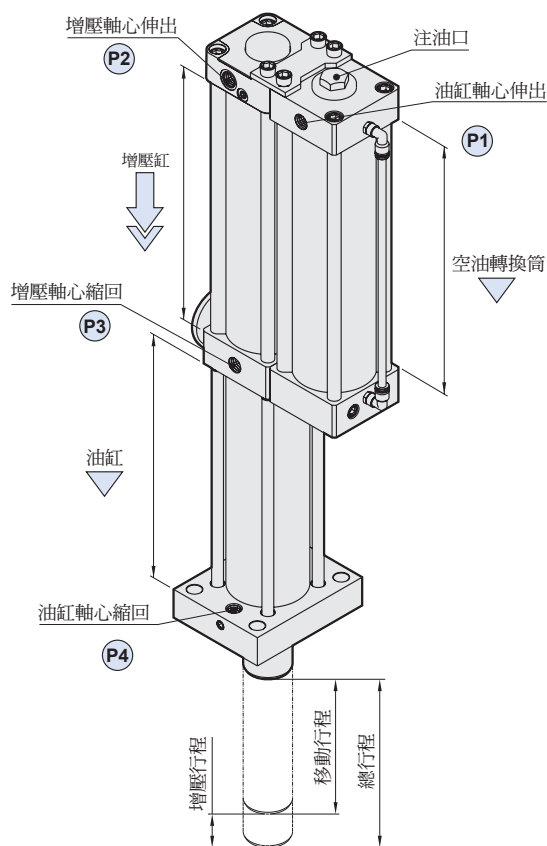
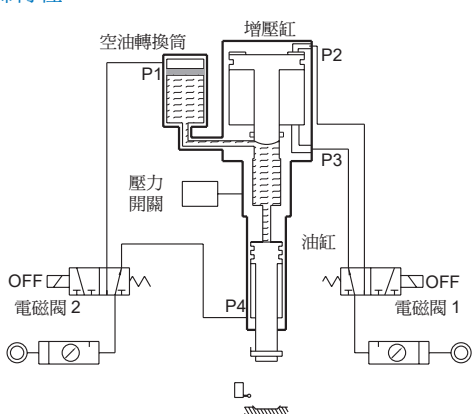

增壓缸行程

型式 推力值 總行程	增壓行程 (mm)					
	1T	3T	5T	8T	10T	
MHPD	50mm	⑤/10/15	⑤/10	⑤/10	⑤/10	⑤/10/15
	75mm	⑤/10/15/20	⑤/10/15	⑤/10/15	⑤/10/15	⑤/10/15
	100mm	⑤/10/15/20	⑤/10/15	⑤/10/15	⑤/10/15	⑤/10/15
	125mm	⑤/10/15/20	⑩/15	⑤/10/15	⑩/15	⑩/15/20
	150mm	⑩/15/20	⑩/15/20	⑩/15/20	⑩/15/20	⑩/15/20
	200mm	⑩/15/20	⑩/15/20	⑩/15/20	⑩/15/20	⑩/15/20
MHPD-Z	50mm	⑤/10/15	⑤/10	⑤/10/15	⑤/10/15	⑤/10/15
	75mm	⑤/10/15/20	⑤/10/15	⑤/10/15	⑤/10/15	⑤/10/15/20
	100mm	⑤/10/15/20	⑤/10/15/20	⑤/10/15	⑤/10/15/20	⑤/10/15/20
	125mm	⑤/10/15/20	⑩/15/20	⑤/10/15/20	⑩/15/20	⑩/15/20
	150mm	⑩/15/20	⑩/15/20	⑩/15/20	⑩/15/20	⑩/15/20
	200mm	⑩/15/20	⑩/15/20	⑩/15/20	⑩/15/20	⑩/15/20

備註 ⑤ = 5mm 增壓行程, ⑩ = 10mm 增壓行程;
 ⑮ = 15mm 增壓行程, ⑳ = 20mm 增壓行程
 短行程: ⑤/10/15/20, 長行程: ⑤/10/15/20

MHPD 外觀尺寸 – 短行程



增壓缸

mindman

MHPD / MHPD-Z

行程表 (短行程)

型式	增壓行程			
	5	10	15	20
1T	50~75	50~125	50~150	75~200
3T	50	50~100	75~150	150~200
5T	50~75	50~150	75~200	150~200
8T	50~75	50~150	75~200	150~200
10T	50	50~125	50~200	125~200
1T-Z	50~75	50~125	50~150	50~200
3T-Z	50	50~100	75~150	100~200
5T-Z	50~75	50~150	50~200	125~200
8T-Z	50~75	50~150	50~200	100~200
10T-Z	50	50~125	50~200	75~200

增壓行程

型式	W			
	5	10	15	20
1T	108	146	184	222
3T	126	187	248	309
5T	135	199	263	327
8T	150	214	278	342
10T	148	212	276	340

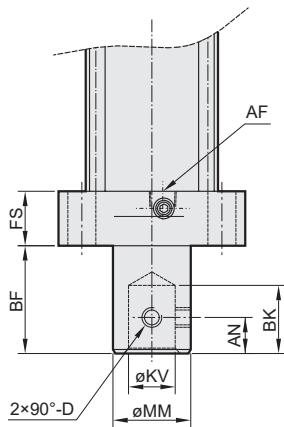

MHPD 型

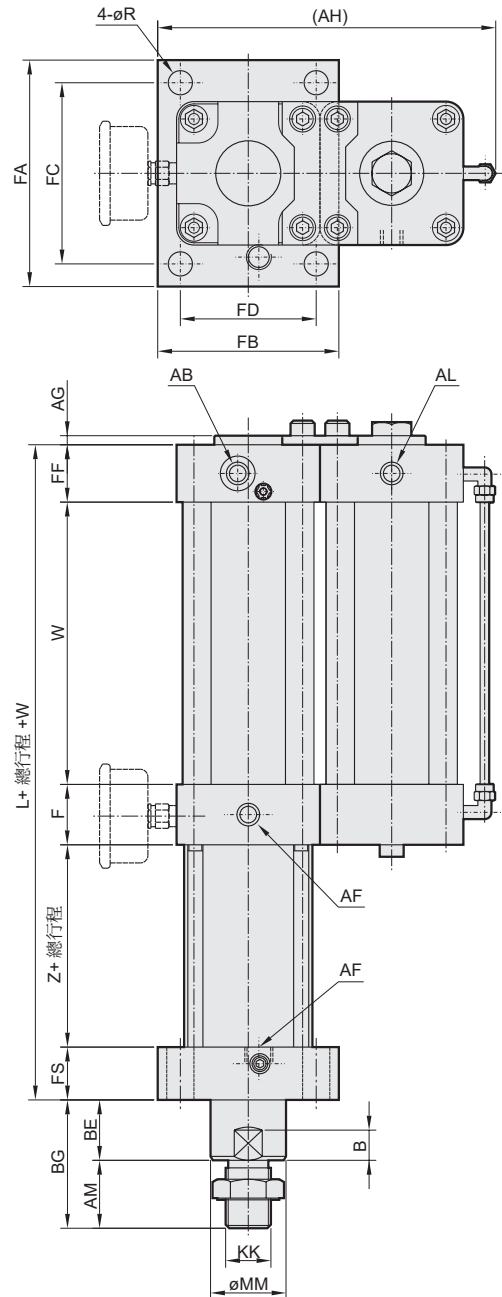
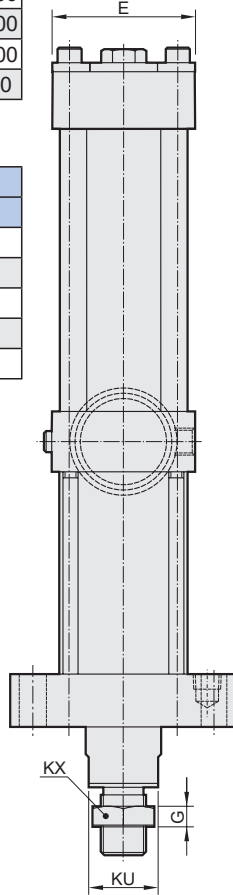

代號 型式	AB	AF	AG	AH	AL	AM	AN	B	BE	BF	BG	BK	D	E	F
1T	G3/8	G3/8	5	187	G3/8	35	12	12	25	40	60	28	M6×1.0	75	40
3T	G3/8	G3/8	6	227	G3/8	45	15	20	40	50	85	35	M6×1.0	95	40
5T	G1/2	G1/2	6	262	G1/2	60	20	20	40	60	100	40	M10×1.5	115	40
8T	G1/2	G1/2	6	315	G1/2	70	25	20	50	70	120	60	M10×1.5	140	45
10T	G3/4	G3/4	6	381	G3/4	80	30	27	60	85	140	50	M10×1.5	174	55

代號 型式	FA	FB	FC	FD	FF	FS	G	KK	KU	KV	KX	L	MM	R	Z
1T	130	100	100	70	32	35	11	M22×1.5	27	16	32	167	30	11	60
3T	150	120	120	90	38	35	13	M30×1.5	36	20	41	187	40	16	74
5T	185	130	155	100	40	45	15	M40×2.0	46	25	57	199	50	17	74
8T	230	160	190	120	45	45	15	M48×2.0	55	30	65	218	60	22	83
10T	270	190	220	140	55	62	20	M56×2.0	65	40	80	243	70	26	71

MHPD 外觀尺寸 – 長行程



增壓缸

MHPD / MHPD-Z

行程表 (長行程)

型式	增壓行程		
	5	10	15
1T	80~125	130~200	155~200
3T	55~100	105~200	155~200
5T	80~125	155~200	-
8T	80~100	155~200	-
10T	75~100	130~200	-
1T-Z	80~125	130~200	155~200
3T-Z	55~100	105~200	155~200
5T-Z	80~125	155~200	-
8T-Z	80~100	155~200	-
10T-Z	55~100	130~200	-

型式	W		
	5	10	15
1T	108	146	184
3T	126	187	248
5T	135	199	263
8T	150	214	278
10T	148	212	276

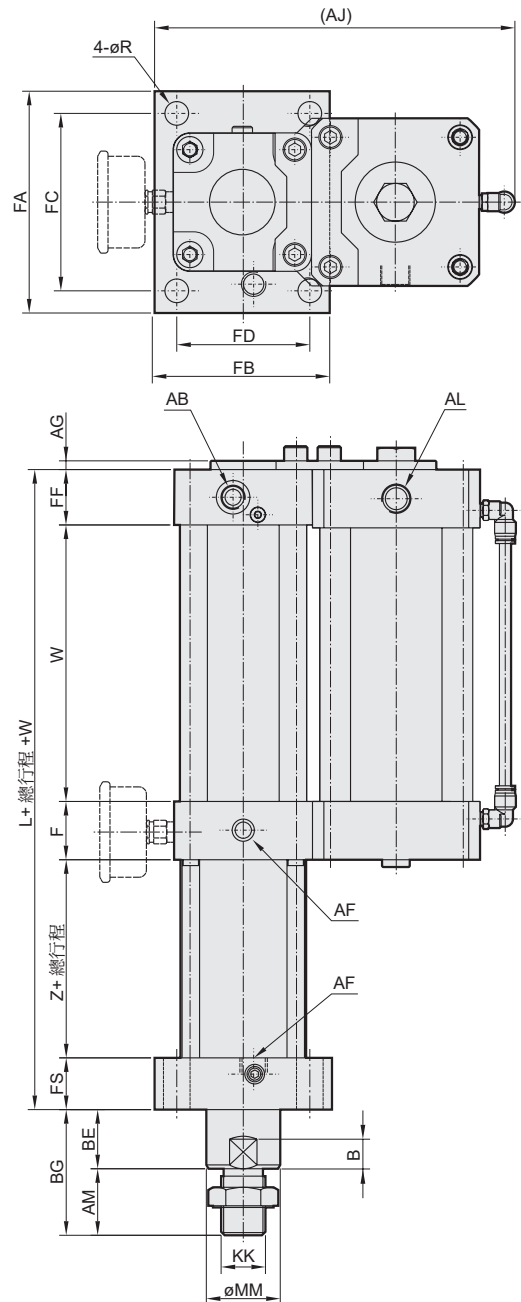
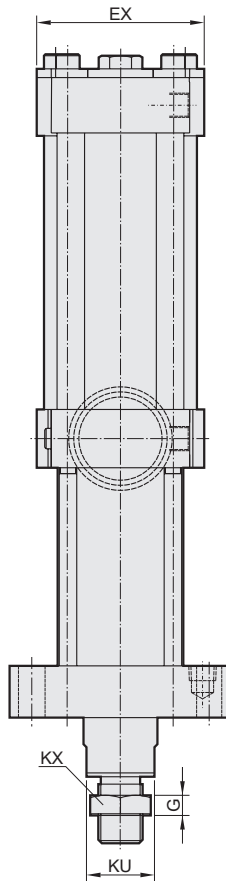
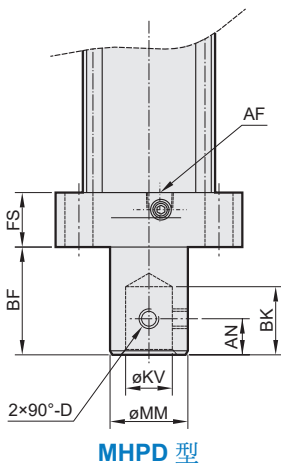

代號 型式	AB	AF	AG	AJ	AL	AM	AN	B	BE	BF	BG	BK	D	EX	F
1T	G3/8	G3/8	5	207	G3/8	35	12	12	25	40	60	28	M6×1.0	95	40
3T	G3/8	G3/8	6	247	G3/8	45	15	20	40	50	85	35	M6×1.0	115	40
5T	G1/2	G1/2	6	287	G1/2	60	20	20	40	60	100	40	M10×1.5	140	40
8T	G1/2	G1/2	6	341	G1/2	70	25	20	50	70	120	60	M10×1.5	174	45
10T	G3/4	G3/4	6	411	G3/4	80	30	27	60	85	140	50	M10×1.5	204	55

代號 型式	FA	FB	FC	FD	FF	FS	G	KK	KU	KV	KX	L	MM	R	Z
1T	130	100	100	70	32	35	11	M22×1.5	27	16	32	167	30	11	60
3T	150	120	120	90	38	35	13	M30×1.5	36	20	41	187	40	16	74
5T	185	130	155	100	40	45	15	M40×2.0	46	25	57	199	50	17	74
8T	230	160	190	120	45	45	15	M48×2.0	55	30	65	218	60	22	83
10T	270	190	220	140	55	62	20	M56×2.0	65	40	80	243	70	26	71