

PARALLEL • ANGULAR  
**GRIPPER**



# About MINDMAN.

 <p><b>QUALITY POLICY</b> Quality advancement &amp; Exceeding customers' demands</p>	 <p><b>600 PEOPLE</b> EMPLOYEES</p>	 <p><b>97 COUNTRIES</b> SALES NETWORK</p>	
<p>Core Business: Manufacture and sale for varieties of high quality automation components.</p>	<p><b>1979</b> FOUNDED</p>	<p><b>No.1</b> Quantity supplied of pneumatic components in Taiwan.</p>	<p>HEADQUARTERS IN <b>TAIPEI</b> CITY, TAIWAN</p>
 <p><b>CHING-CHENG HUANG</b> PRESIDENT</p>	 <p><b>CAPITAL</b> USD 12,558,000</p>	<p>MANUFACTURE BASE IN <b>TAINAN</b> CITY, TAIWAN</p>	 <p><b>90,000 m<sup>2</sup></b> Plant Size</p>

**M**indman Industrial Co., Ltd. was established in 1979 with a destination to provide high quality automation components for a wide variety of industries.

During the past 40 years, Mindman has devoted to the expansion of our product range. Thanks to our R&D department, we are proud to possess the diversified product lineup includes solenoid valves, air treatment units, pneumatic cylinders, electric actuators and all different types of fluid power accessories.

We always believe that fast delivery of automation components is the key of success in the market. Through the complete vertical integration of all manufacturing processes and automated warehouse, we are confident to achieve on time delivery.

To keep quality high during the whole production process, we implement the strict quality control standard. We thoroughly control the process via standard operation procedure (SOP), statistical process control system (SPC) and total productive management (TPM). Most important of all, Mindman commits to providing the products with 100% inspection after assembly.

Currently, Mindman products are exported to more than 90 countries around the world. We devoted ourselves to building the relationship with customers worldwide and provide them with the strong support, such as online 3D drawing, inventory check and promotional program...etc. In the vast automation market, Mindman will spare no effort in establishing a brand – a worldclass premium automation components supplier.



<p><b>ISO 9001</b> Quality</p> 
<p><b>ISO 14001</b> Environment</p> 
<p><b>ISO 45001</b> Health and Safety</p> 

## Quality Assurance Certification

Passed ISO 9001, ISO 14001 and ISO 45001 international certification.





*Connect with*  
**ROBOT**

Connect gripper and robotic arm to achieve various workpiece gripping applications.

# PARALLEL GRIPPER

## 2-FINGER

All gripping force is based on the conditions below.

- ▶ Operation Pressure 0.5 MPa.
- ▶ Gripping Length 20 mm.
- ▶ Outer diameter gripping.

\* MCHS, MCHJ series: Under the condition of clamping length 40mm and operation pressure 0.6 MPa.

**MCH\*** series  
Model selection

P. 6

- ▶ Gripper selection.
- ▶ Selection suggestions.
- ▶ Selection example.



**MCHC** series  
2-finger

P. 7

- ▶ Using linear ball bearing.
- ▶ Excellent repeatability.
- ▶ 7 kinds of mounting jaw available.
- ▶ Gripping force 4N~65N.



## 2-FINGER

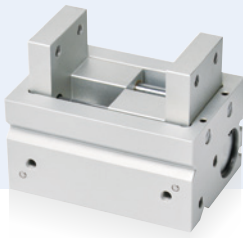

**MCHU** series  
2-finger

P. 23

- ▶ Using mechanism to achieve parallel gripping.
- ▶ Designed for long soft-jaws installation.
- ▶ Gripping force 20N~60N.



**MCHB** series  
2-finger

P. 27

- ▶ Using mechanism to achieve parallel gripping.
- ▶ Economic type.
- ▶ Gripping force 15N~125N.

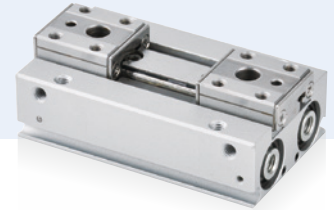

**MCHD** series  
2-finger

P. 33

- ▶ Using linear ball bearing.
- ▶ Excellent repeatability.
- ▶ Flat profile.
- ▶ Gripping force 15N~140N.

## 2-FINGER

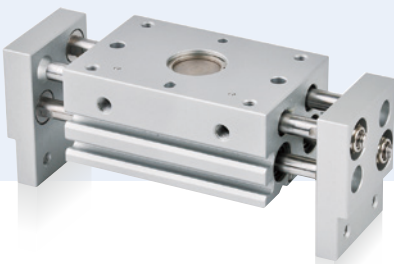

**MCHX** series  
2-finger

P. 43

- ▶ Using rack and pinions to achieve parallel gripping.
- ▶ Long gripping stroke.
- ▶ High rigidity.
- ▶ Gripping force 16N~400N.



**MCHH** series  
2-finger

P. 50

- ▶ Using rack and pinions to achieve parallel gripping.
- ▶ High rigidity.
- ▶ Gripping force 20N~125N.



**MCHS** series  
2-finger

P. 55

- ▶ Using transmission cam to achieve parallel gripping.
- ▶ High rigidity.
- ▶ Gripping force 75N~3400N.

# PARALLEL GRIPPER

## 3-FINGER



**MCHG2** series  
3-finger

P. 65

- ▶ Using transmission cam to achieve centering gripping.
- ▶ High rigidity.
- ▶ Gripping force 12N~1300N.



**MCHJ** series  
3-finger

P. 72

- ▶ Using transmission cam to achieve centering gripping.
- ▶ High rigidity.
- ▶ Gripping force 110N~5250N.

**All gripping force is based on the conditions below.**

- ▶ Operation Pressure 0.5 MPa.
- ▶ Gripping Length 20 mm.
- ▶ Outer diameter gripping.



# ANGULAR GRIPPER

## 2-FINGER

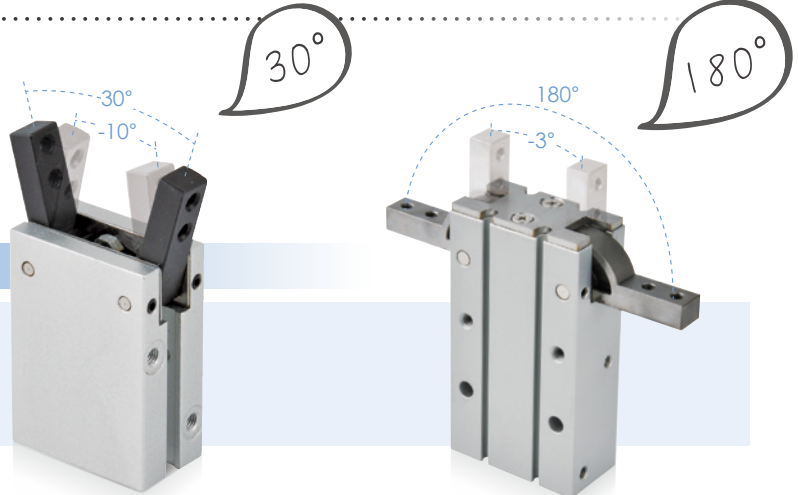

**MCHA** series  
2-finger

P. 79

- ▶ Simple structure with high stability.
- ▶ Economic type.
- ▶ Gripping force 10N~150N.

**MCHY** series  
2-finger

P. 84

- ▶ Using cams to achieve angular gripping.
- ▶ Gripping force 8N~114N.

## SENSOR SWITCH



**RDE** series

P. 89

- ▶ Non-contact
- ▶ NPN, PNP



**RDFE** series

P. 90

- ▶ Non-contact
- ▶ NPN, PNP



**RDGV** series

P. 91

- ▶ Non-contact
- ▶ NPN, PNP



**RDP8** series

P. 92

- ▶ NPN, PNP

## GRIPPER

### Gripper selection

- Depends on the coefficient of friction and the gripping conditions between soft fingers and work piece.

When gripping a workpiece as in the figure as shown above:

**F**: Gripping force of single finger (N)

**n**: Number of finger

**$\mu$** : Coefficient of friction between the attachments and the workpiece

**m**: Workpiece mass (kg)

**g**: Gravitational acceleration (=9.8m/s<sup>2</sup>)

**a**: Safe factor

the conditions under which the workpiece will not drop are,

$$n \times \mu F > m \times g$$

Therefore,

$$F \geq \frac{m \times g}{n \times \mu}$$

With "a" representing the extra margin, "F" is determined by the following formula:

$$F \geq \frac{m \times g}{n \times \mu} \times a$$

### Model selection suggestions

- For normal gripping and carrying usage, the recommended safe factor (a) is 4.
- The value of gripping force of single finger can be found at the gripping force table.
- The safe factor (a) have to be higher if the gripper is using with a great accelerated velocity or impaction condition.

### Model selection example

In the motion process did not produce high acceleration, deceleration or impact forces, Workpiece mass: 0.3kg, Gripping method: External gripping, Operating pressure: 0.5 MPa, Coefficient of friction ( $\mu$ ): 0.1, Holding position: L=20mm (no overhang)

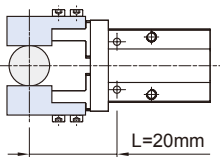

- Based on the above formula, the required gripping force can be derived:
 
$$F \geq \frac{0.3 \times 9.8}{2 \times 0.1} \times 4 \geq 60(N)$$
- From Effective Gripping Force Fig, Operating pressure: 0.5 MPa; Holding position: 20 mm Effective gripping force is greater than 60 (N) So selected **MCHC-25** grippers.

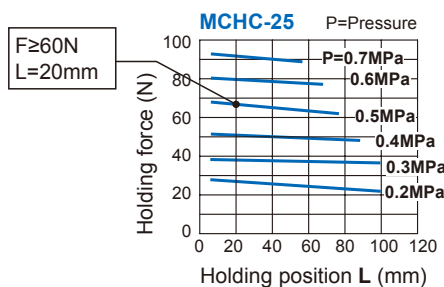

### Parallel gripper (2-Finger)

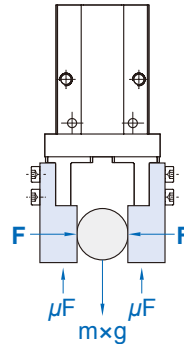

### Angular gripper

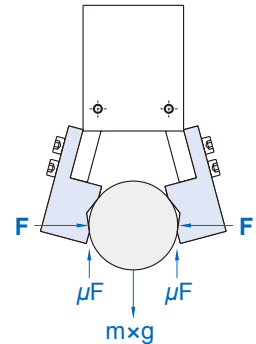

### Parallel gripper (3-Finger)

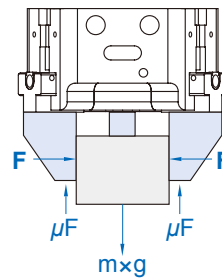

### Parallel gripper (4-Finger)

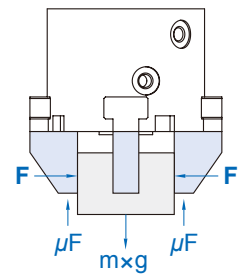

In the motion process did not produce high acceleration, deceleration or impact forces, Workpiece mass: 0.05kg, Gripping method: External gripping, Operating pressure: 0.3 MPa, Coefficient of friction ( $\mu$ ): 0.1, Holding position: L=40mm (no overhang)

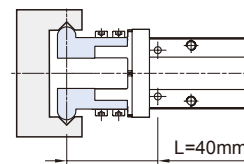

- Based on the above formula, the required gripping force can be derived:
 
$$F \geq \frac{0.05 \times 9.8}{2 \times 0.1} \times 4 \geq 10(N)$$
- From Effective Gripping Force Fig, Operating pressure: 0.3 MPa; Holding position: 40 mm Effective gripping force is greater than 10 (N) So selected **MCHC-16** grippers.

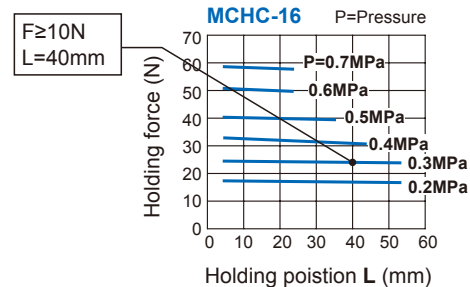



 *Connect with*

## *AIR CYLINDER*

Connect gripper with cylinder to achieve regular workpiece gripping.

# MCHC series [ feature ]

PARALLEL GRIPPER (2-Finger)

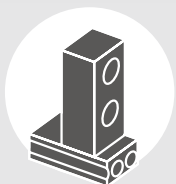

7 kinds of mounting jaw available



Linear ball bearing guide for high rigidity and precision



Whole gripping set made with martensitic stainless steel

## ▶ VARIOUS FINGER TYPES

● Standard



● Narrow



● Side tapped mounting



● Through hole



● Flat



## ▶ REPEATABILITY

±0.01 mm

## ▶ STROKE

Standard and long stroke.

The long stroke type is approximately double compare with standard type.

## ▶ ACTING

Single / Double acting  
N.C. / N.O. (optional)



## ▶ MOUNTING POSITION

Bottom / Side / Front



## ▶ SENSOR SWITCH

RDE, RNE, RPE series  
Standard with magnet  
Embedded sensor design

## ▶ POSITIONING HOLES

With positioning holes for fast positioning when changing grippers.

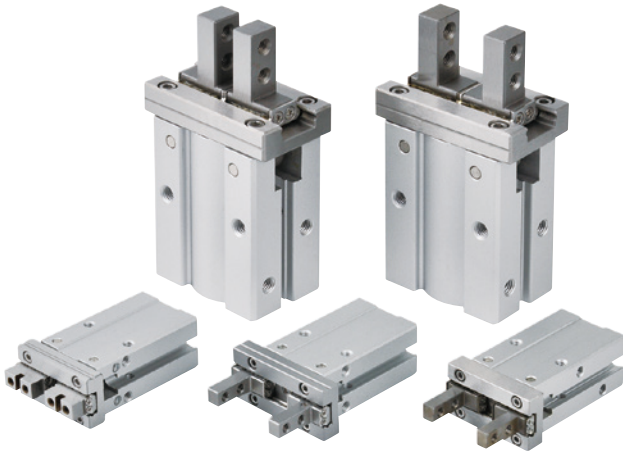

### Order example

MCHC □ – 20 – □ N

Model	Tube ID.	Style (*1)	Type (*2)
MCHC (Standard stroke)	6	Blank: Double acting	Blank: Standard 1: Side tapped mounting 2: Standard (Through hole)
	10	Blank: Double acting S: Single acting / Normally open C: Single acting / Normally closed	Blank: Standard 1: Side tapped mounting 2: Standard (Through hole) 3: Flat N: Narrow N1: Narrow type side tapped mounting N2: Narrow (Through hole)
	16		
	20		
25			
MCHCL (Long stroke)	10	Blank: Double acting	Blank: Standard 1: Side tapped mounting 2: Standard (Through hole)
	16		
	20		
	25		

#### \*1. STYLE

Blank: Double acting	S: Single acting / Normally open	C: Single acting / Normally closed

#### \*2. TYPE

Blank: Standard	1: Side tapped mounting	2: Standard (Through hole)	3: Flat
N: Narrow	N1: Narrow type side tapped mounting	N2: Narrow (Through hole)	

### Features

- Integral linear guide used for high rigidity and high precision.
- The material of finger is martensitic stainless steel.
- Body thickness tolerance ±0.05mm.
- Bottom pin holes for accurate re-locating.
- Grooves on the body for sensor switch to be inserted into.
- The gripping stroke of long-stroke type is approximately double compare with standard type.
- Magnetic as standard.

### Specification

Model	MCHC						
Acting type	Double acting / Single acting						
Tube I.D. (mm)	6	10	16	20	25		
Opening / Closing stroke (mm)	4	4(8)	6(12)	10(18)	14(22)		
Port size	M3×0.5		M5×0.8				
Medium	Air						
Operating pressure range (MPa)	Double acting	0.15~0.7	0.2~0.7	0.1~0.7			
	Single acting	–	0.35~0.7	0.25~0.7			
Ambient temperature	-10~+60°C (No freezing)						
Repeatability	± 0.01 mm						
Max. operating frequency (c.p.m)	180 (120)						
Lubricator	Not required						
Sensor switch (*2)	*1	RDE, RDE-D: Non-contact					
Weight (g)	Double acting	Standard	27	55	124	250	461
		Long stroke	–	56	125	252	463
	Single acting	Flat type	–	53	124	244	450
		Standard	–	70	145	270	490

\*1. Tube I.D. ø6 use RDFE(V) sensor switch.

\*2. RDE\*, RDFE(V) specification, please refer to page 89, 90.

\*3. ( ) value for long stroke.

### Gripping force

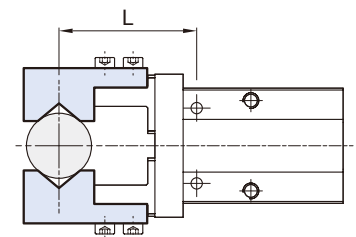

Tube I.D. (mm)		6	10	16	20	25
Double acting	External	3.3(0.3)	11(1.1)	34(3.5)	42(4.3)	65(6.6)
	Internal	6.1(0.6)	17(1.7)	45(4.6)	66(6.7)	104(10.6)
Single acting / Normally open	External	–	7.1(0.7)	27(2.8)	33(3.4)	45(4.6)
Single acting / Normally closed	Internal	–	13(1.3)	38(3.9)	57(5.8)	83(8.5)

\* Operation pressure 0.5 MPa, gripping length 20mm, the effective gripping force for each finger is \*\*\* N(kgf).

### Double acting

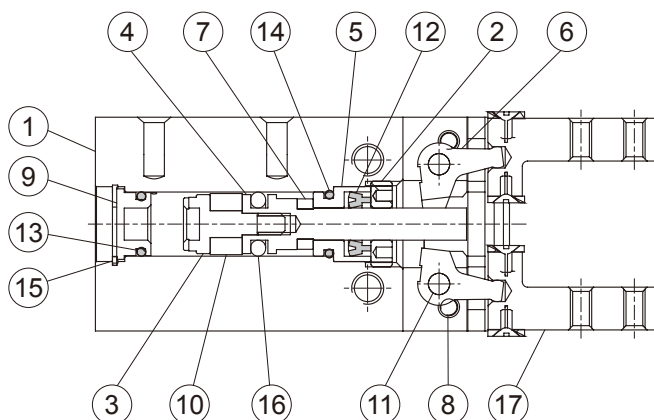

### Material

No.	Part name	Material	Q'y	Repair kits (inclusion)
1	Body	Aluminum alloy	1	
2	Front cap	Stainless steel	1	
3	Magnet holder	Stainless steel	1	
4	Piston rod	Stainless steel	1	
5	Rod cover	Stainless steel	1	
6	Lever	Stainless steel	2	
7	Cushion pad	PU	1	●
8	Screw	Stainless steel	4	
9	Head cover	Aluminum alloy	1	
10	Magnet ring	Magnet material	1	
11	Pin	Steel	2	
12	Rod packing	NBR	1	●
13	O-ring	NBR	1	
14	O-ring	NBR	1	
15	Snap ring	Carbon steel	1	●
16	Piston packing	NBR	1	●
17	Gripping set	Stainless steel (*)	1	

\* Bearing steel balls as standard.

### Order example of repair kits

Tube I.D.	Repair kits
$\varnothing 6$	<b>PS-MCHC-6</b>

**Double acting**

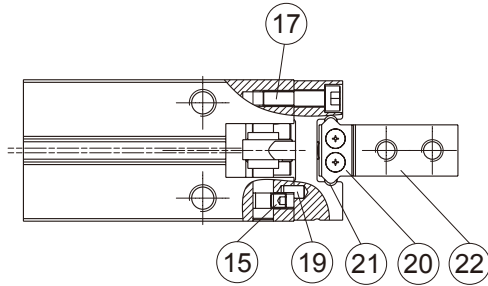

**Single acting**

Normally open

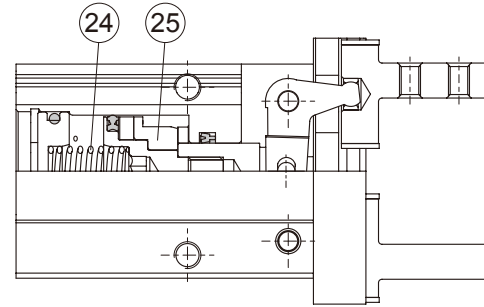

**Single acting**

Normally closed

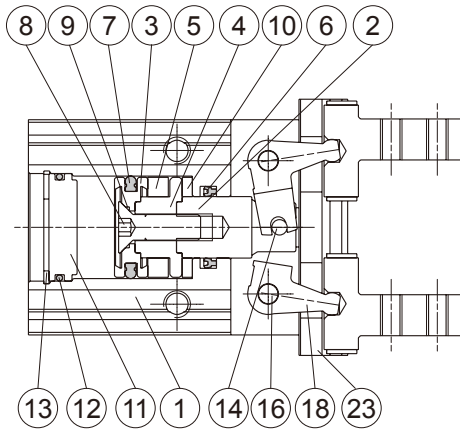
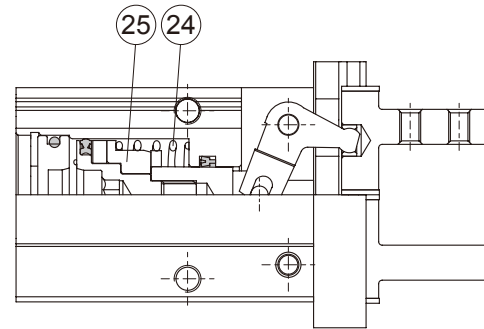

**Material**

No.	Tube I.D. Part name	10	16	20	25	Q'y	Repair kits (inclusion)
1	Body	Aluminum alloy				1	
2	Piston rod	Stainless steel				1	
3	Piston	Aluminum alloy				1	
4	Piston R	*1	Aluminum alloy			1	
5	Magnet ring	Magnet material				1	
6	Rod packing	NBR				1	●
7	Piston packing	NBR				1	●
8	Screw	—	Stainless steel			1	
9	O-ring	—	NBR			1	●
10	Cushion pad	PU				1	●
11	Head cover	Aluminum alloy				1	
12	Cover ring	NBR				1	●
13	Stop ring	*2	Stainless steel			1	
14	Spindle river	Carbon steel				1	
15	Screw	Carbon steel				4	
16	Grip rivet	Carbon steel				2	
17	Bolt	Stainless steel				4	
18	Lever	Stainless steel				2	

No.	Tube I.D. Part name	10	16	20	25	Q'y	Repair kits (inclusion)
19	Pin	Carbon steel				2	
20	Roller stopper	Stainless steel				4	
21	Steel balls	Bearing steel				24	
22	Finger	Stainless steel				2	
23	Guide	Stainless steel				1	
24	Magnet holder	Stainless steel				1	
25	Stop ring	Stainless steel				1	

\*1. Stainless steel \*2. Carbon steel

**Order example  
of repair kits**

Tube I.D.	Repair kits
$\varnothing 10$	<b>PS-MCHC-10</b>
$\varnothing 16$	<b>PS-MCHC-16</b>
$\varnothing 20$	<b>PS-MCHC-20</b>
$\varnothing 25$	<b>PS-MCHC-25</b>

### Double acting

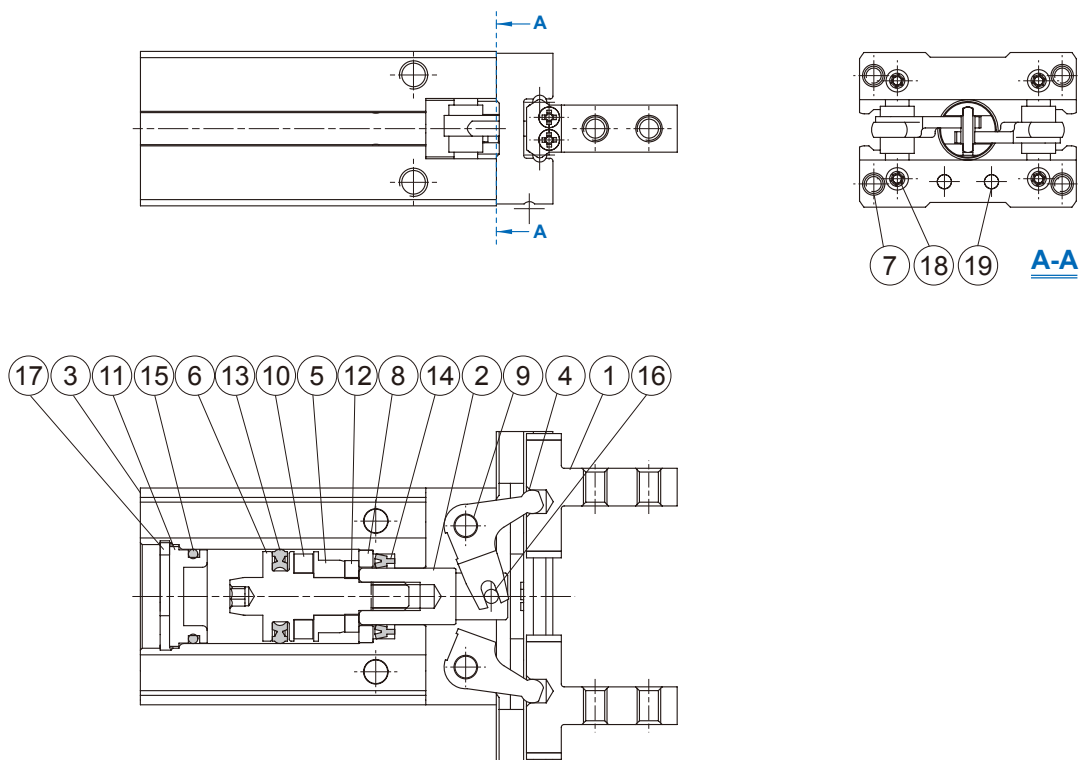

### Material

No.	Tube I.D. Part name	10	16	20	25	Q'y	Repair kits (inclusion)
1	Gripping set	Stainless steel (*1)				1	
2	Piston rod	Stainless steel				1	
3	Body	Aluminum alloy				1	
4	Lever	Stainless steel				2	
5	Spring holder	Stainless steel				1	
6	Piston	Stainless steel				1	
7	Bolt	Stainless steel				4	
8	Stop ring	*2		-		1	
9	Grip rivet	Mild carbon steel				2	
10	Magnet ring	Magnet material				1	
11	Head cover	Aluminum alloy				1	
12	Gasket	NBR				1	●
13	Piston packing	NBR				1	●
14	Rod packing	NBR				1	●
15	O-ring	NBR				1	●
16	Spindle river	Carbon steel				1	
17	Snap ring	*3	Stainless steel			1	
18	Hexgon screw	Stainless steel				4	
19	Pin	Carbon steel				2	

\*1. Bearing steel balls as standard.

2. Stainless steel 3. Carbon steel

### Order example of repair kits

Tube I.D.	Repair kits
$\varnothing 10$	PS-MCHCL-10
$\varnothing 16$	PS-MCHCL-16
$\varnothing 20$	PS-MCHCL-20
$\varnothing 25$	PS-MCHCL-25

### Confirmation of external force on fingers

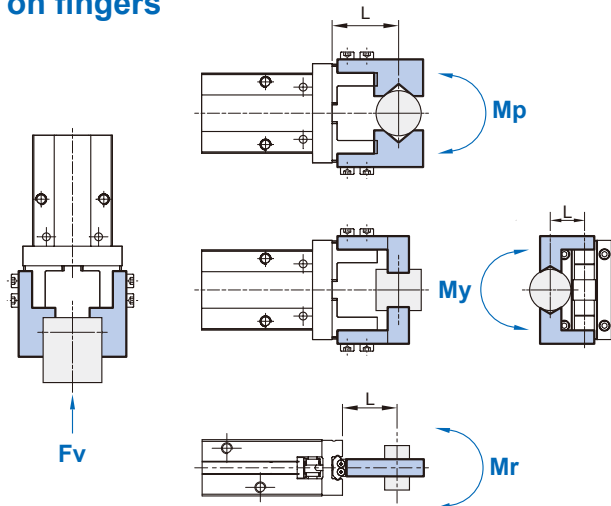

L: distance to the point at which the load is applied (mm)

Tube I.D. (mm)	Allowable vertical load Fv (N)	Maximum allowable moment		
		Pitch moment Mp (N-m)	Yaw moment My (N-m)	Roll moment Mr (N-m)
6	10	0.04	0.04	0.08
10	58	0.26	0.26	0.53
16	98	0.68	0.68	1.36
20	147	1.32	1.32	2.65
25	255	1.94	1.94	3.88

\* Values for load and moment in the table indicate static values.

### Installation of sensor switch

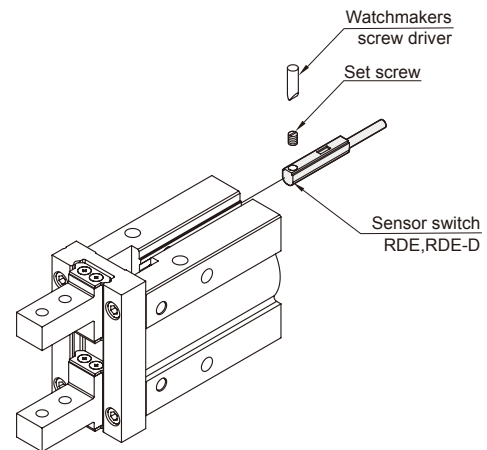

### Allowable load calculation

$$\text{Allowable load } F(N) = \frac{M(\text{maximum allowable moment})(N \cdot m)}{L(m)}$$

#### Example

When a static load of  $f=20\text{N}$  is operating, which applies pitch moment to point  $L=25\text{mm}$  from the **MCHC-16** guide.

$$\begin{aligned} \text{Allowable load } F(N) &= \frac{0.68 (N \cdot m)}{25 \times 10^{-3} (m)} \\ &= 27.2 (N) \end{aligned}$$

Load  $f=20 (N) < 27.2 (N)$ , so can be used.

### Model selection suggestions

1. For normal gripping and carrying usage, the recommended safe factor (a) is 4.
2. The value of gripping force of single finger can be found at the gripping force table.
3. The safe factor (a) have to be higher if the gripper is using with a great accelerated velocity or impaction condition.

### Effective gripping force (Double acting)

Indication of effective force.

The effective gripping force shown in the graphs to the right is expressed as F, which is the thrust of one finger, when both fingers and attachments are in full contact with the workpiece as shown in the figure below.

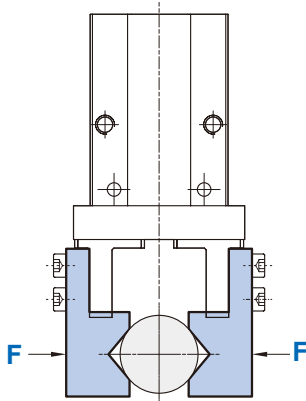

1N=0.102 kgf  
1MPa=10.2 kgf/cm<sup>2</sup>

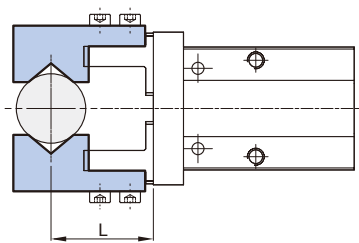

External grip

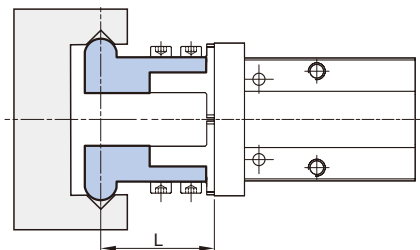

Internal grip

### External gripping force

### Internal gripping force

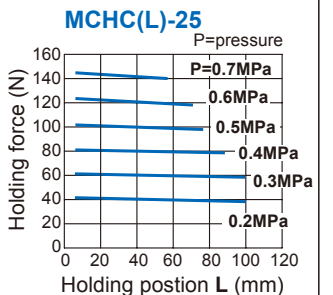
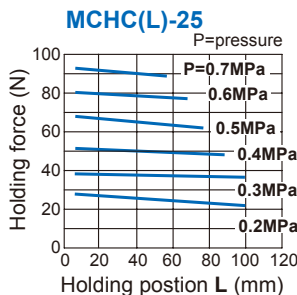
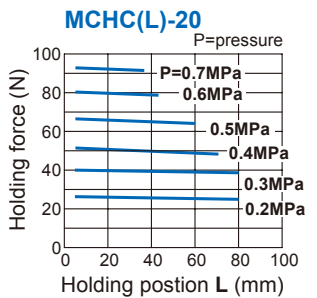
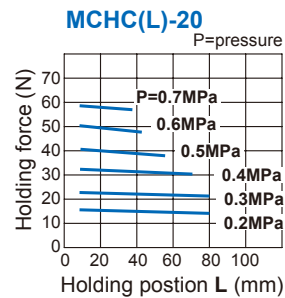
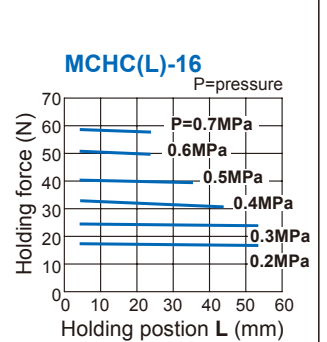
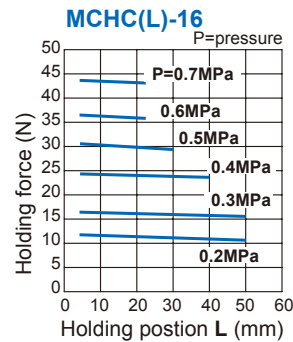
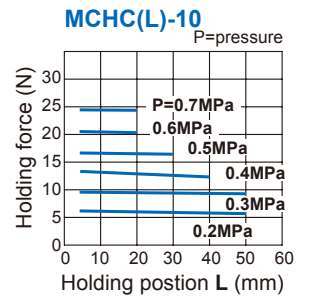
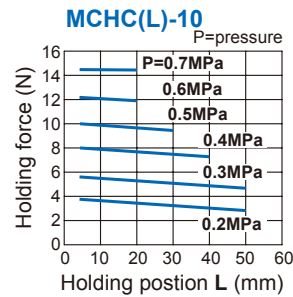
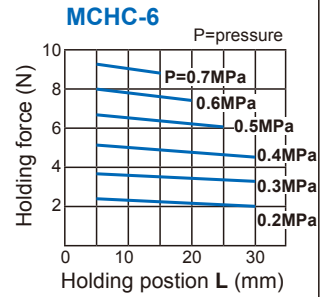
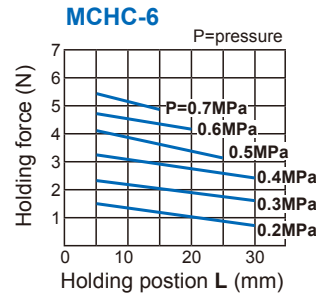

### Effective gripping force (Single acting)

Indication of effective force.

The effective gripping force shown in the graphs to the right is expressed as F, which is the thrust of one finger, when both fingers and attachments are in full contact with the workpiece as shown in the figure below.

1N=0.102 kgf  
1MPa=10.2 kgf/cm<sup>2</sup>

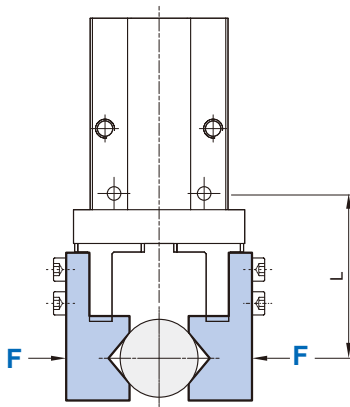

**External grip**  
(Single acting / Normally open)

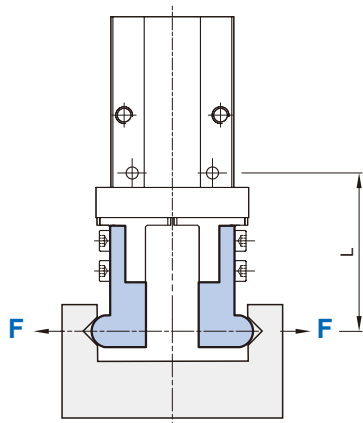

**Internal grip**  
(Single acting / Normally closed)

### External gripping force Single acting / N.O.

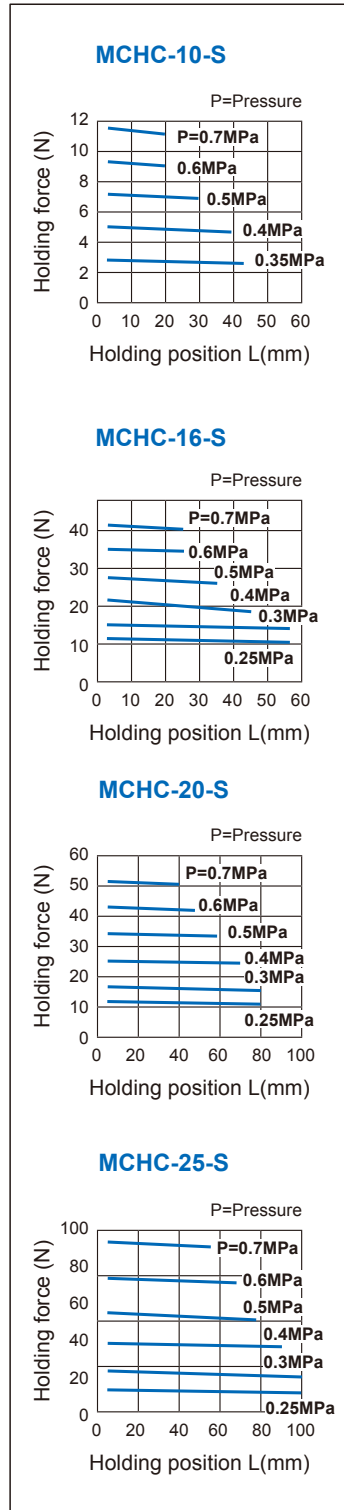

### Internal gripping force Single acting / N.C.

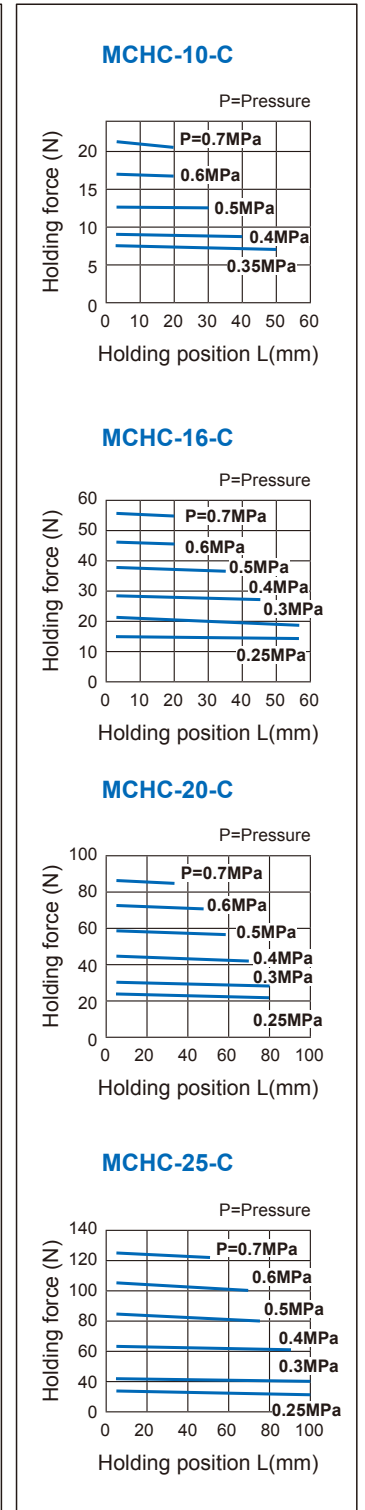

### Confirmation of gripping point

- The air gripper should be operated so that the workpiece gripping point "L" and the amount of overhang "H" stay within the range shown for each operating pressure given in the graphs to the right.
- If the workpiece gripping point goes beyond the range limits, this will have an adverse effect on the life the air gripper.

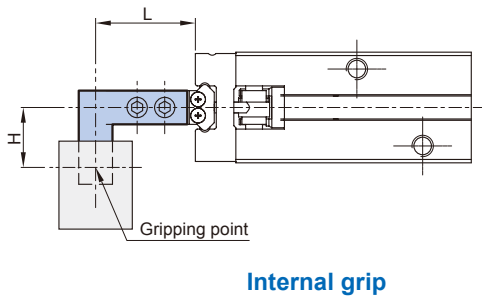
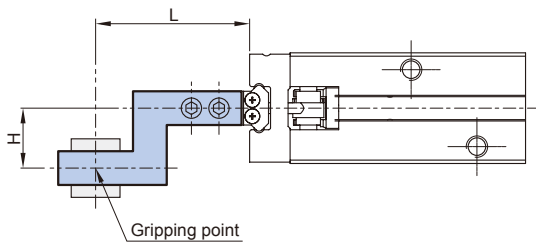

### External gripping

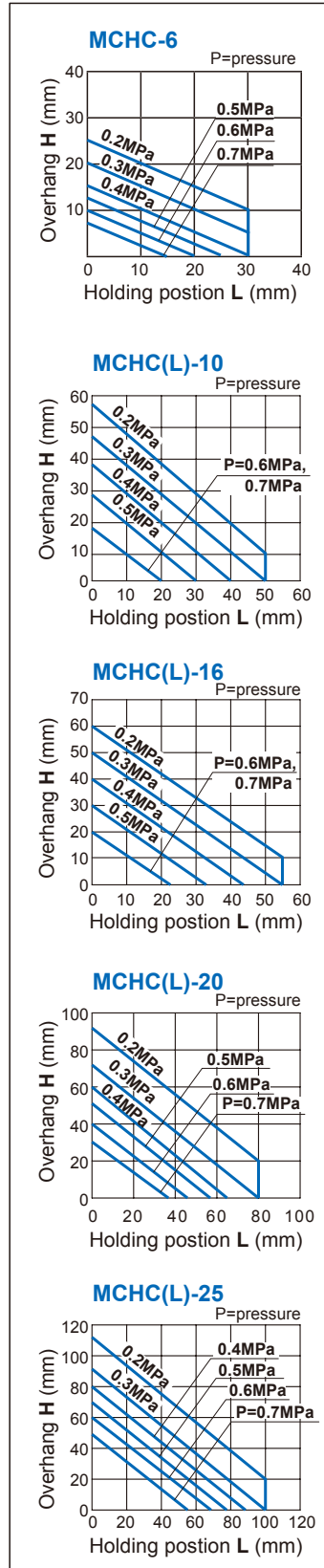

### Internal gripping

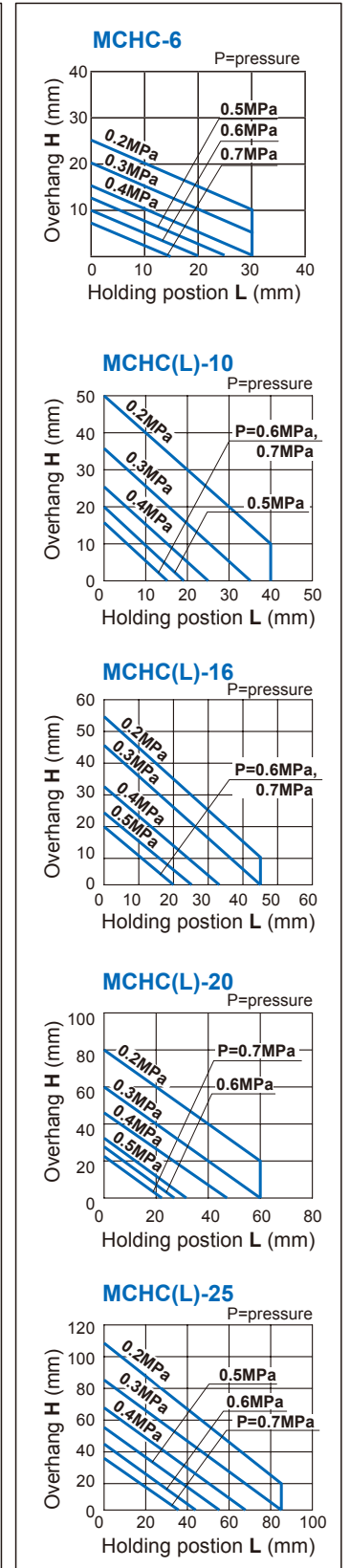

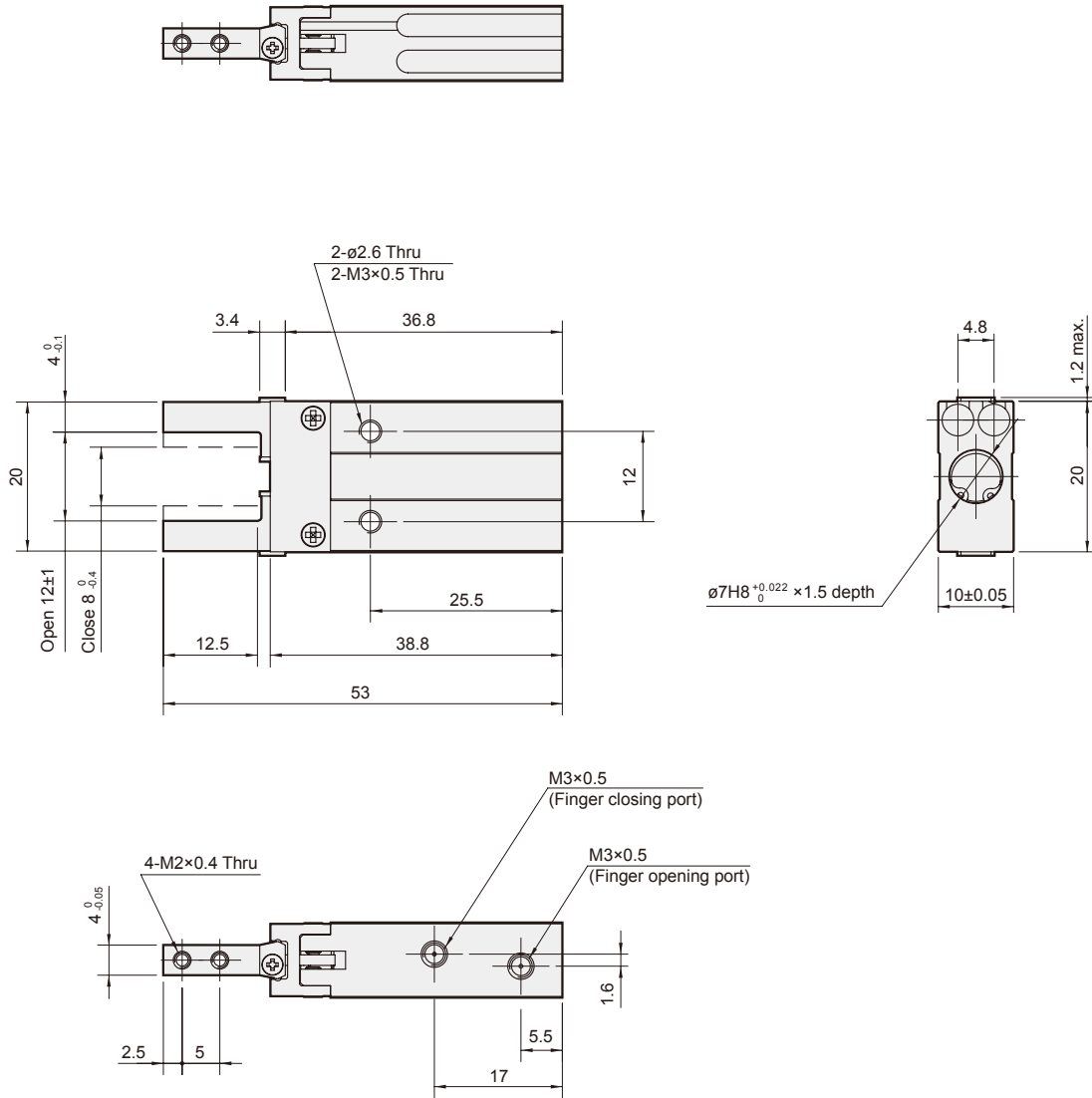

## PARALLEL GRIPPER (2-Finger)

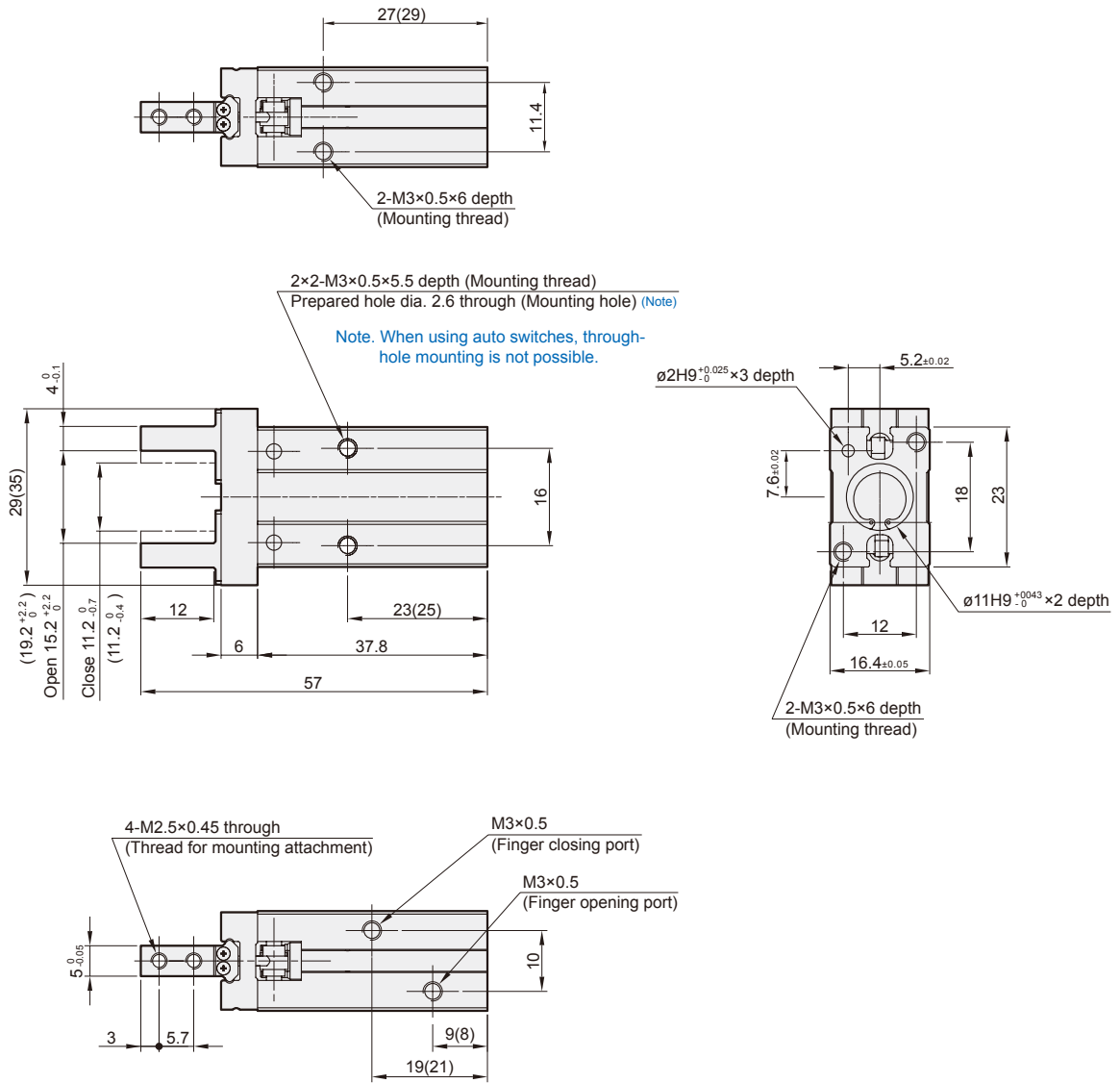

\*( ) for long stroke value.

### Finger position – Narrow type

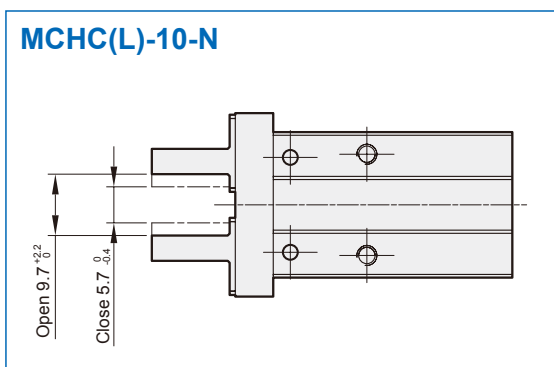

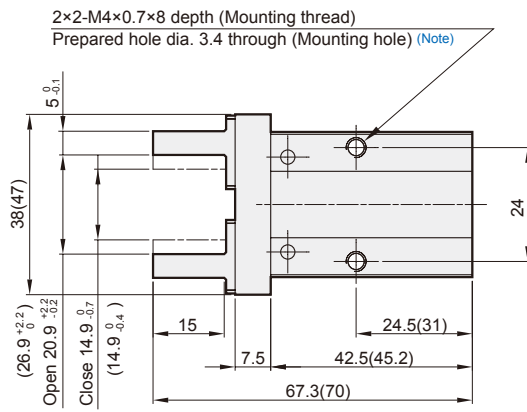
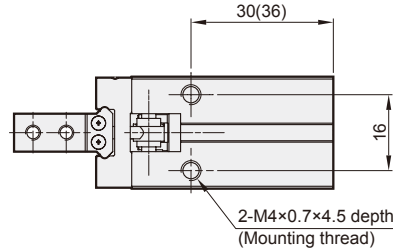

Note. Through-hole mounting is not possible when using the auto switch at the square groove.

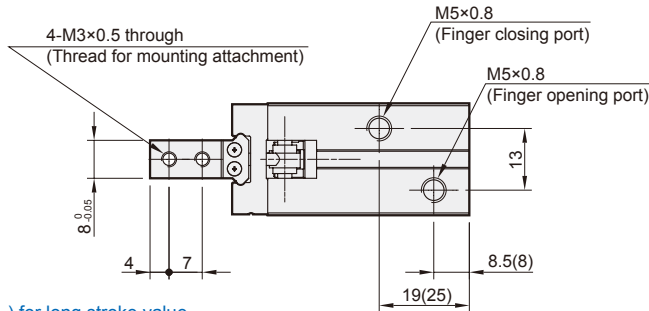
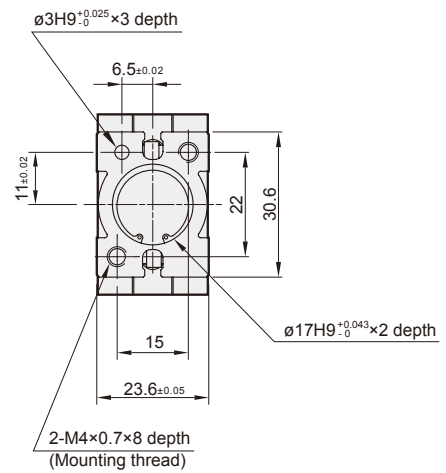

\*( ) for long stroke value.

### Finger position – Narrow type

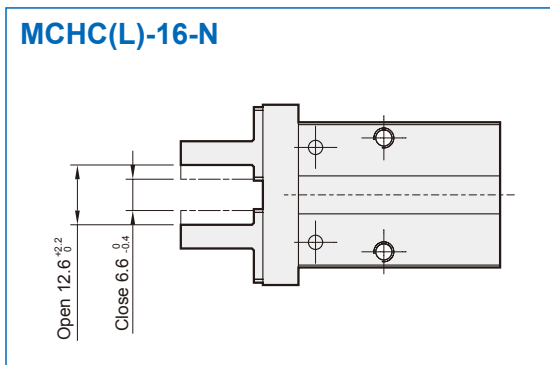

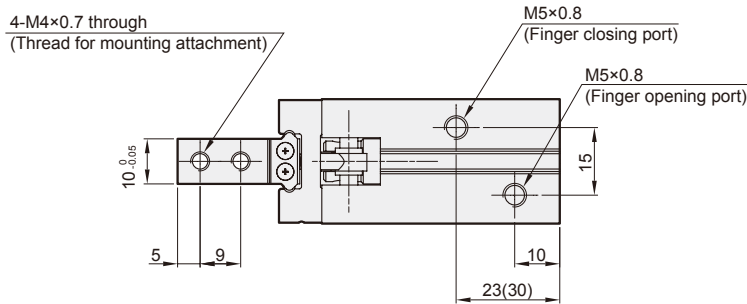
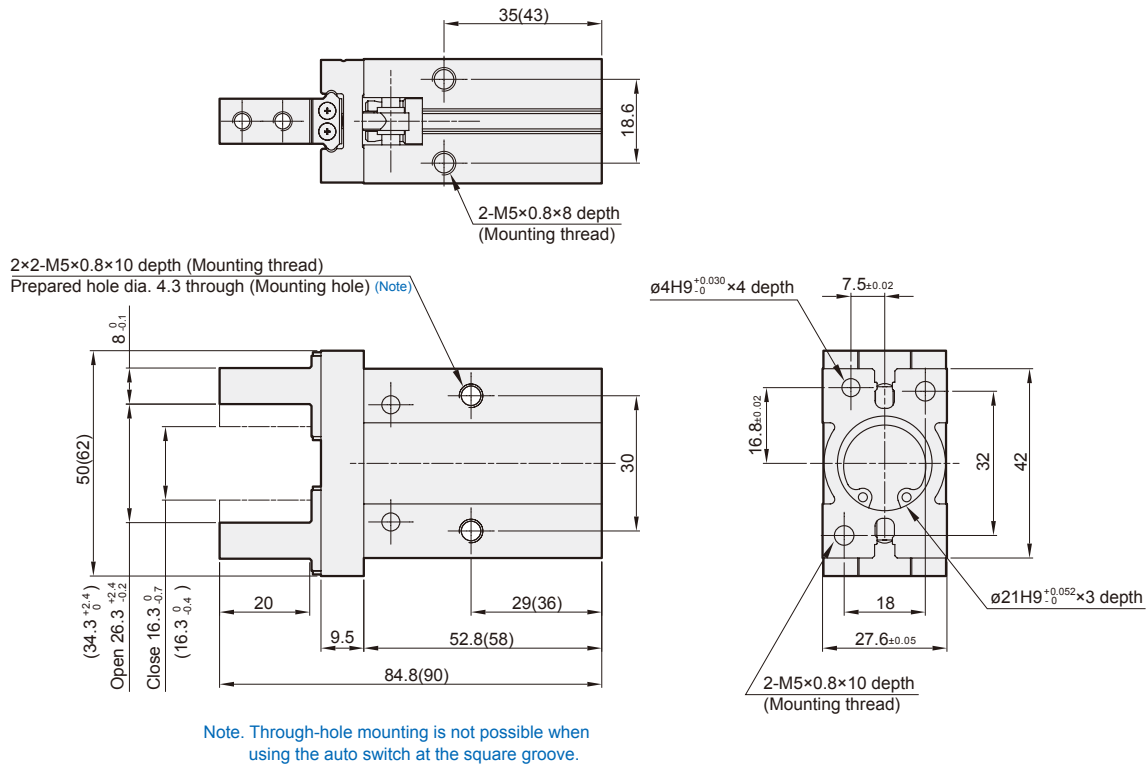

\*( ) for long stroke value.

### Finger position – Narrow type

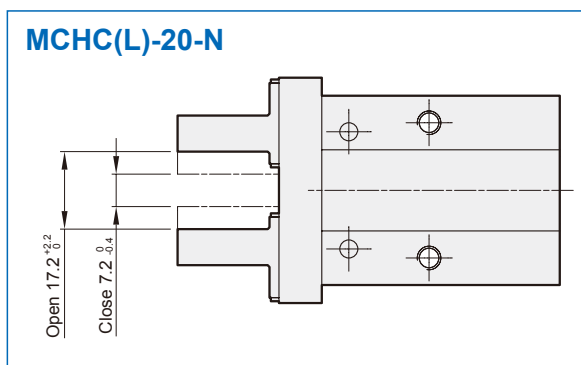

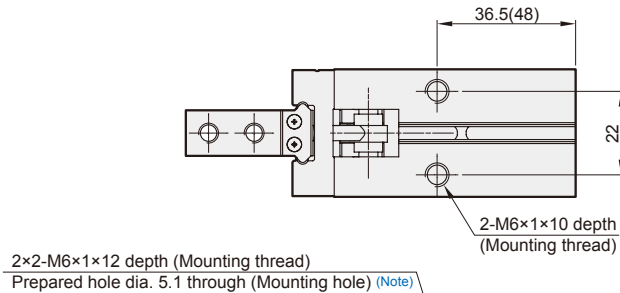

2x2-M6x1x12 depth (Mounting thread)  
Prepared hole dia. 5.1 through (Mounting hole) (Note)

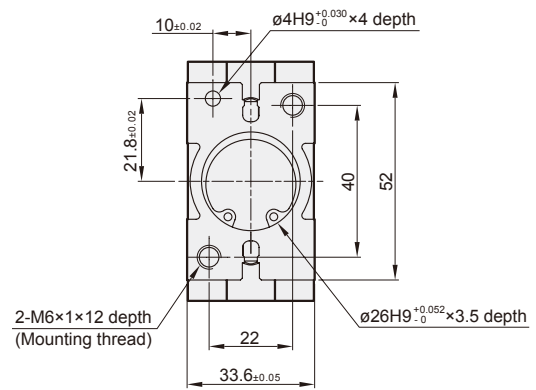
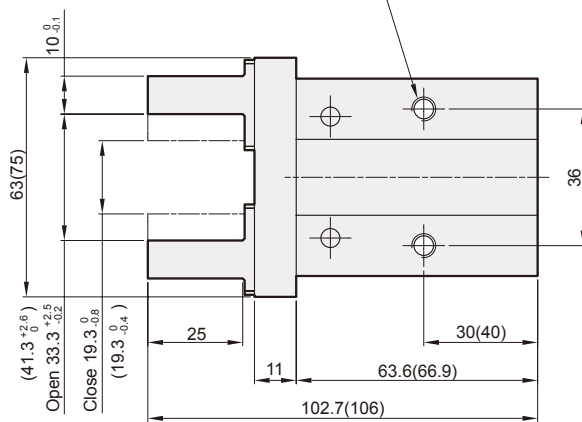

Note. Through-hole mounting is not possible when using the auto switch at the square groove.

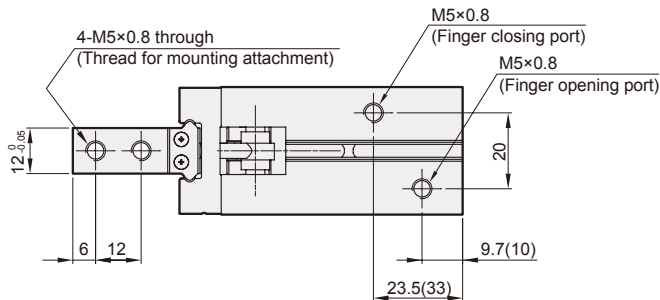

( ) for long stroke value.

### Finger position – Narrow type

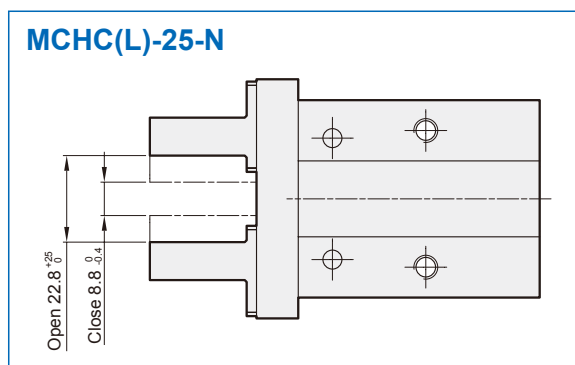

### MCHC\*-1, N1 Side tapped mounting

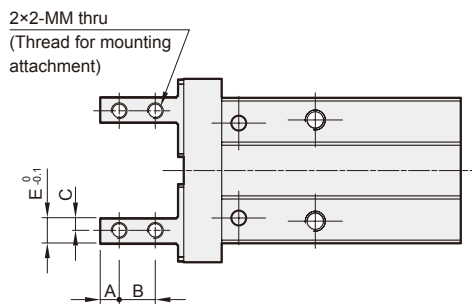

Code Tube I.D.	A	B	C	E	MM
6	2.5	5	2	4	M2×0.4
10	3	5.7	2	4	M2.5×0.45
16	4	7	2.5	5	M3×0.5
20	5	9	4	8	M4×0.7
25	6	12	5	10	M5×0.8

### MCHC\*-2, N2 Through hole type

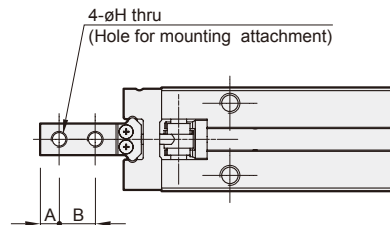

Code Tube I.D.	A	B	H
6	2.5	5	$\phi 2.4$
10	3	5.7	$\phi 2.9$
16	4	7	$\phi 3.4$
20	5	9	$\phi 4.5$
25	6	12	$\phi 5.5$

### MCHC\*-3 Flat type

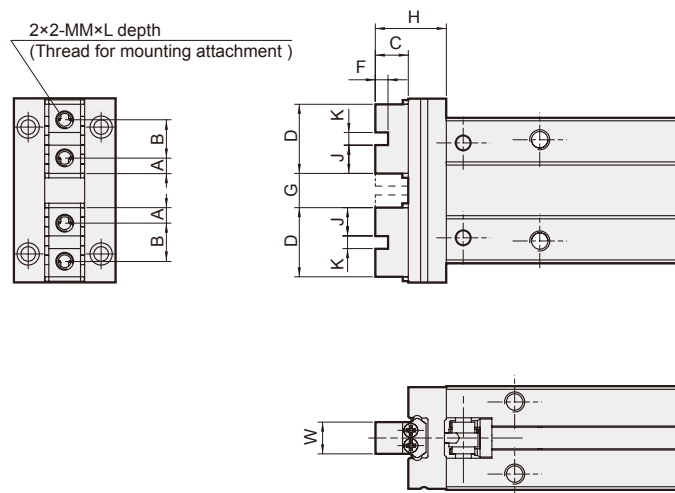

Code Tube I.D.	A	B	C	D	F	G		H	J	K	MM	L	W
						Open	Closed						
10	2.45	6	5.2	10.9	2	5.4 <sup>+2.2</sup> <sub>0</sub>	1.4 <sup>0</sup> <sub>-0.2</sub>	11.2	4.45	2H9 <sup>+0.025</sup> <sub>0</sub>	M2.5×0.45	5	5 <sup>0</sup> <sub>-0.05</sub>
16	3.05	8	8.3	14.1	2.5	7.4 <sup>+2.2</sup> <sub>0</sub>	1.4 <sup>0</sup> <sub>-0.2</sub>	15.8	5.8	2.5H9 <sup>+0.025</sup> <sub>0</sub>	M3×0.5	6	8 <sup>0</sup> <sub>-0.05</sub>
20	3.95	10	10.5	17.9	3	11.6 <sup>+2.3</sup> <sub>0</sub>	1.6 <sup>0</sup> <sub>-0.2</sub>	20	7.45	3H9 <sup>+0.025</sup> <sub>0</sub>	M4×0.7	8	10 <sup>0</sup> <sub>-0.05</sub>
25	4.90	12	13.1	21.8	4	16 <sup>+2.5</sup> <sub>0</sub>	2 <sup>0</sup> <sub>-0.2</sub>	24.1	8.9	4H9 <sup>+0.03</sup> <sub>0</sub>	M5×0.8	10	12 <sup>0</sup> <sub>-0.05</sub>



*Connect with*

.....

## **AUTOMATIC ASSEMBLY MACHINE**

Connect gripper with cylinder to achieve regular workpiece gripping.



### Features

- Compact design, light weight with rugged construction.
- Jaws mounted to wear resistant bush guides.
- Magnetic as standard.

### Specification

Model	MCHU		
Acting type	Double acting		
Tube I.D. (mm)	12	16	20
Stroke	15	20	25
Fluid	Air 0.2~0.7 MPa		
Ambient temperature	-10~+60°C (No freezing)		
Lubrication (*1)	Not required		
Repeatability	±0.03 mm		
Sensor switch (*2)	RDFE(V): Non-contact		
	RNFE(V): NPN, RPFE(V): PNP		
Weight (kg)	0.16	0.29	0.58

\*1. Sliding area of jaws need scheduled relubrication.  
 \*2. R\*FE(V) specification, please refer to page 90.

### Order example

**MCHU – 12 M**

MODEL

TUBE I.D.

M: Magnet

\* Magnetic as standard.

12  
16  
20

### Capacity

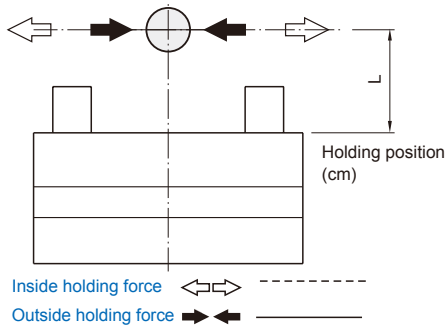

**MCHU-12**

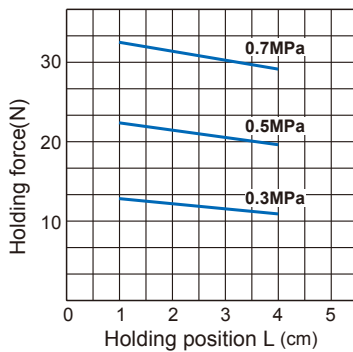

**MCHU-16**

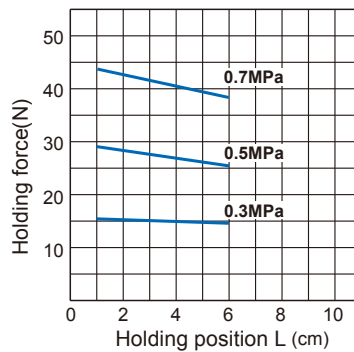

**MCHU-20**

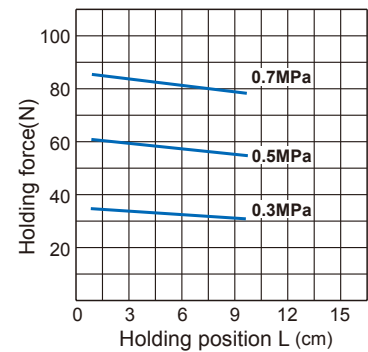

### Model selection suggestions

\* Finger selection please refer to page 6.

1. For normal gripping and carrying usage, the recommended safe factor (a) is 4.
2. The value of gripping force of single finger can be found at the gripping force table.
3. The safe factor (a) have to be higher if the gripper is using at high acceleration or impact condition.

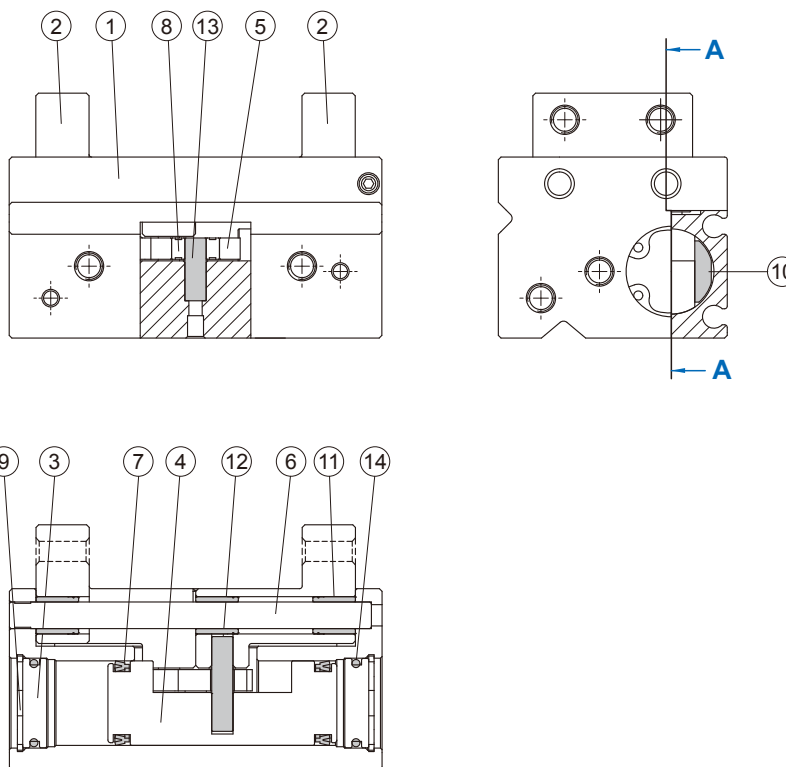

A-A

### Material

No.	Tube I.D. Part name	12	16	20	Q'y	Repair kits (inclusion)
1	Body	Aluminum alloy			1	
2	Finger	Aluminum alloy			2	
3	Cover	Aluminum alloy			2	
4	Piston	Stainless steel			1	
5	Cam	SCM			1	
6	Guide rod	SUS	Carbon steel		2	
7	Piston packing	NBR			2	●
8	Bearing	Bearing steel			1	
9	Snap ring	Spring steel			2	
10	Magnet	Magnet material			1	
11	Bush	Carbon steel			6	
12	Pin	Carbon steel			2	
13	Pin	Carbon steel			1	
14	O-ring	NBR			2	●

### Order example Repair kits

Tube I.D.	Repair kits
ø12	<b>PS-MCHU-12</b>
ø16	<b>PS-MCHU-16</b>
ø20	<b>PS-MCHU-20</b>

PARALLEL GRIPPER (2-Finger)

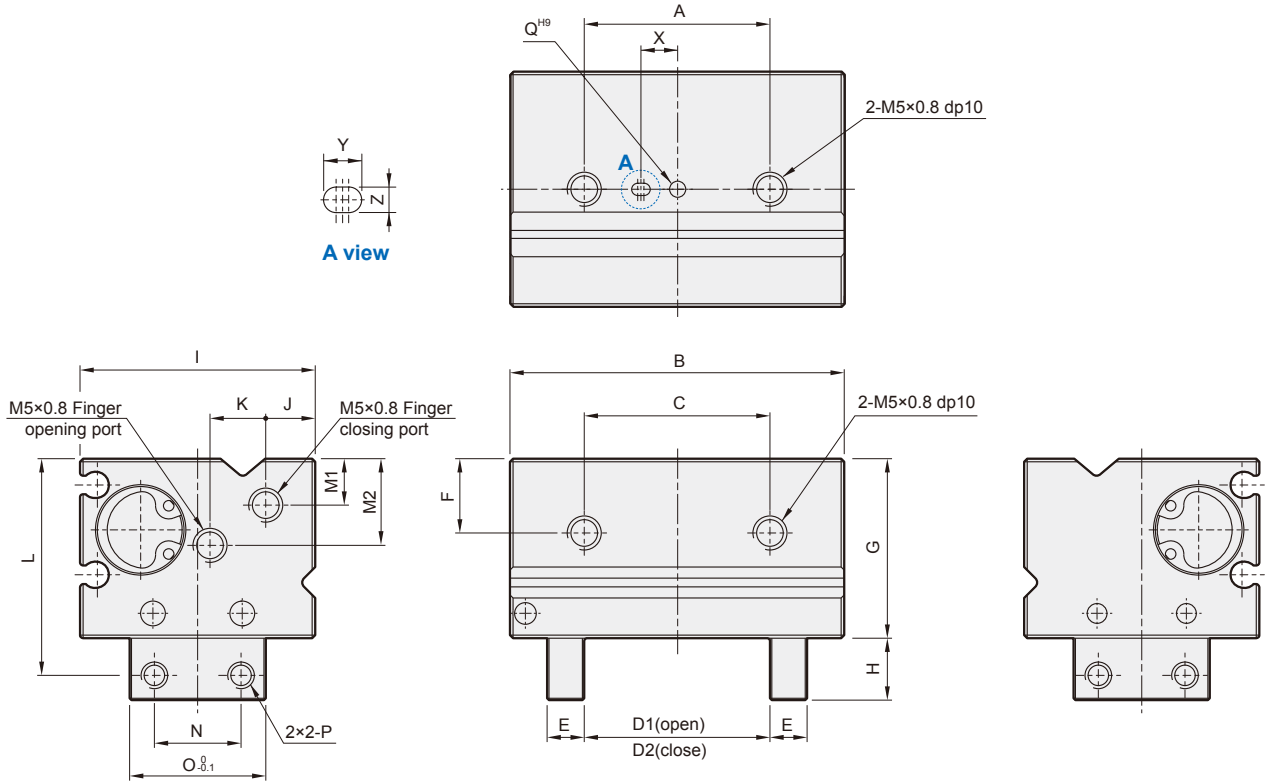

Code Tube I.D.	A	B	C	D1	D2	E	F	G	H	I	J	K	L	M1	M2	N	O	P	Q <sup>H9</sup>	X	Y	Z <sup>H9</sup>
12	30	54	30	30	15	6	12	29	10	38	8	9	35	7.5	14	14	22	M4×0.7	$\varnothing 2^{+0.025}_0 \times 2dp$	6	3	$2^{+0.025}_0 \times 2dp$
16	40	70	40	40	20	10	13.5	34	12	43	8	11	41	7.5	12.5	18	30	M5×0.8	$\varnothing 3^{+0.025}_0 \times 4dp$	10	4	$3^{+0.025}_0 \times 4dp$
20	60	82	60	50	25	10	15	43	22	56	10	15	59	9	20	20	35	M5×0.8	$\varnothing 3^{+0.025}_0 \times 6dp$	15	4	$3^{+0.025}_0 \times 6dp$

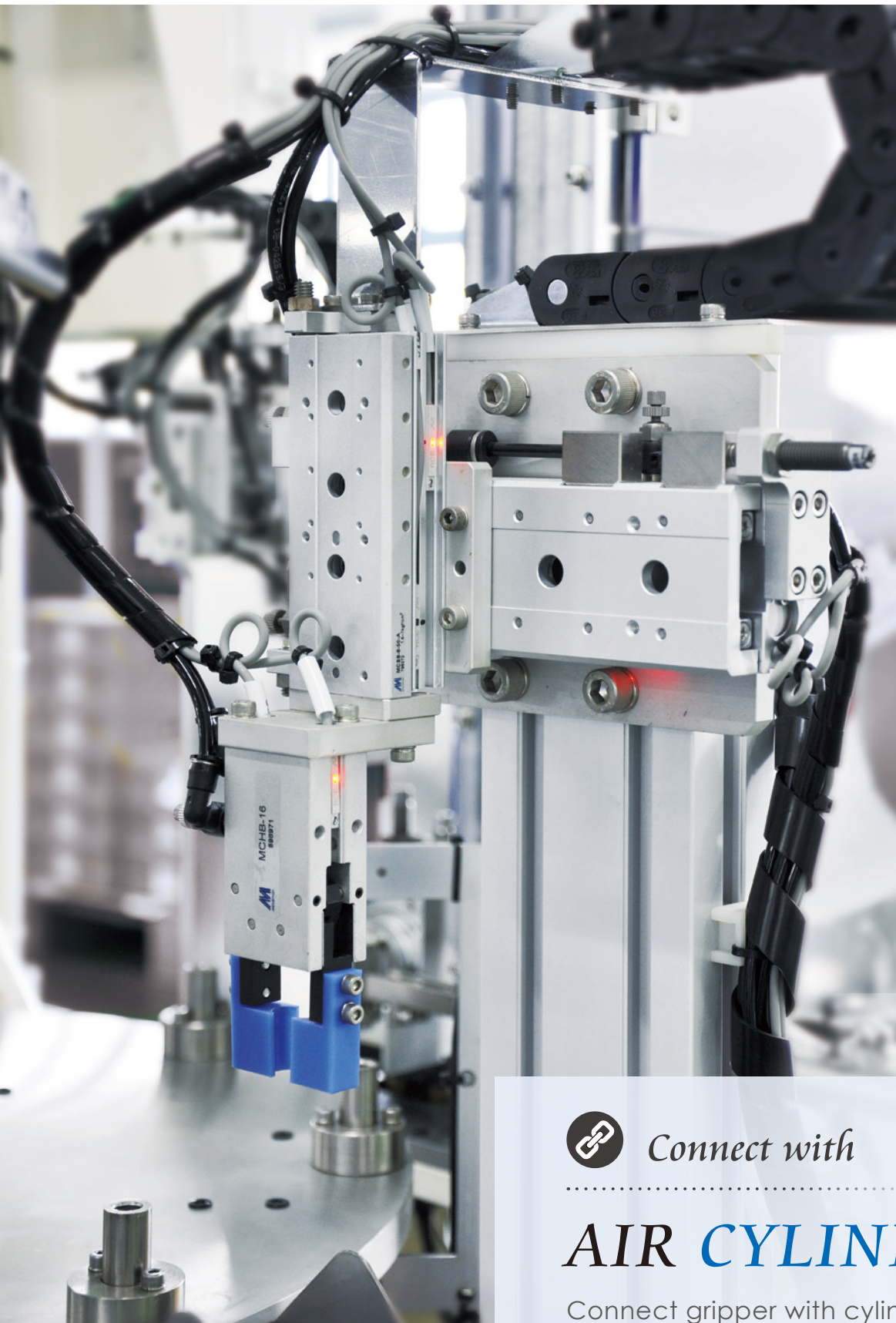

*Connect with*

## **AIR CYLINDER**

Connect gripper with cylinder to achieve regular workpiece gripping.



### Features

- Available with comprehensive range of Tube I.D. 12~32 mm.
- Highly accurate air driven device for holding work-piece.
- Magnetic as standard.

### Specification

Model		MCHB				
Acting Type		Double / Single acting				
Tube I.D. (mm)		12	16	20	25	32
Port size		M3×0.5	M5×0.8			
Medium		Air				
Operating pressure range	Double acting	0.15~0.7 MPa				
	Single acting	0.2~0.7 MPa				
Ambient temperature		-5~+60°C (No freezing)				
Max. operating frequency (c.p.m)		180				
Lubrication	Cylinder	Not required				
	Lever	Grease (Actuation at)				
Max. arm length (L) (mm)		30	40	60	70	85
Lever open / close stroke		6	8	12	14	16
Sensor switch (*)		RDE, RDE-D: Non-contact				
Weight (g)	Double acting	66	144	255	419	719
	Single acting	66.5	145	257	422	722

### Order example

**MCHB — 16 — S**

MODEL

TUBE I.D.

ACTING

12

16

20

25

32

Blank: Double acting  
S: Single acting  
(Normally open)

\* RDE, RDE-D specification, please refer to page 89.

### Length of gripping point

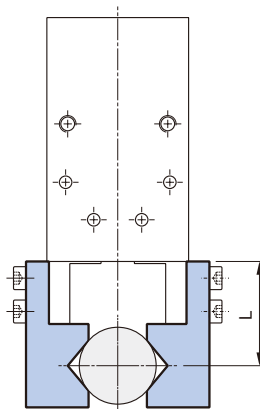

### Installation of sensor switch

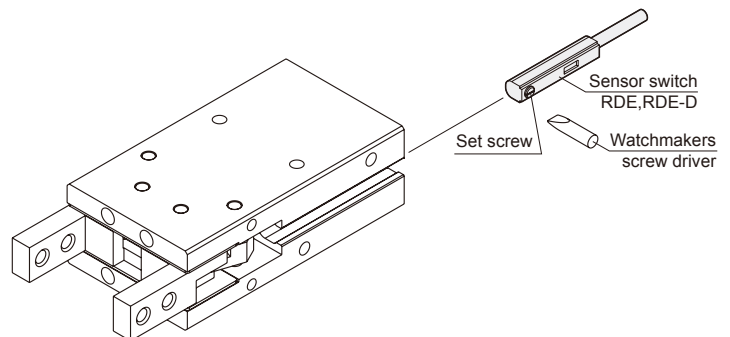

### Double acting

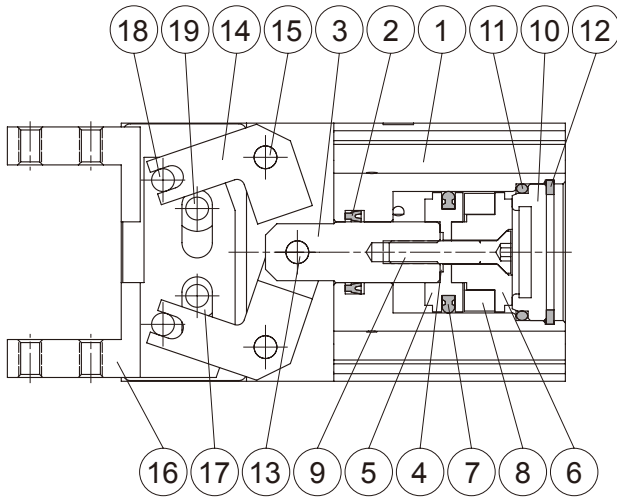

### Single acting

Normally open

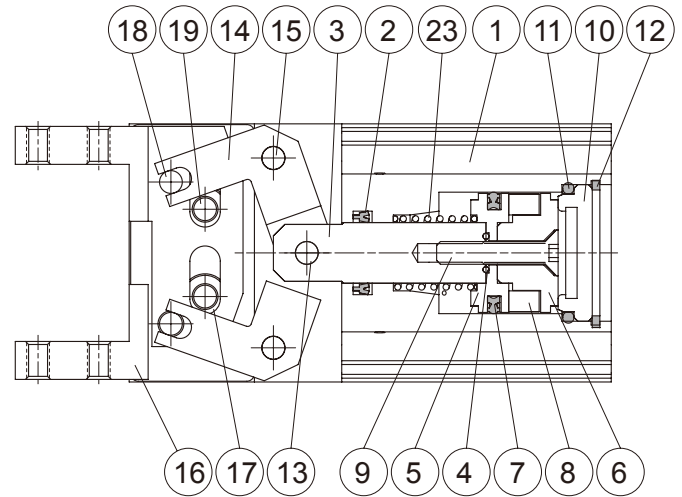

### Material

No.	Part name	Material	Q'y	Repair kits (inclusion)
1	Body	Aluminum alloy	1	
2	Rod packing	NBR	1	●
3	Piston rod	Stainless steel	1	
4	Gasket	NBR	1	●
5	Piston-R	Aluminum alloy	1	
6	Piston-H	Aluminum alloy	1	
7	Piston packing	NBR	1	●
8	Magnet ring	Magnet material	1	
9	Screw	Stainless steel	1	
10	Head cover	Carbon steel	1	
11	Cover ring	NBR	1	●
12	Stop ring	Spring steel	1	
13	Spindle river	Bearing steel	1	
14	Grip per	Carbon steel	2	
15	Grip rivet	Carbon steel	2	
16	Grip per	Carbon steel	2	
17	Bush	Stainless steel	4	
18	Grip rivet	Bearing steel	2	
19	Grip rivet	Carbon steel	2	
20	Screw	SCM	4	
21	Screw	SCM	4	
22	Washer for grip	Stainless steel	2	
23	Spring	Spring steel	1	

### Order example of repair kits

Tube I.D.	Repair kits
ø12	<b>PS-MCHB-12</b>
ø16	<b>PS-MCHB-16</b>
ø20	<b>PS-MCHB-20</b>
ø25	<b>PS-MCHB-25</b>
ø32	<b>PS-MCHB-32</b>

### Effective gripping force (Double acting)

Indication of effective force.

The effective gripping force shown in the graphs to the right is expressed as F, which is the thrust of one finger, when both fingers and attachments are in full contact with the workpiece as shown in the figure below.

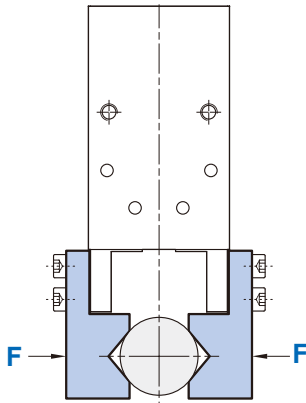

$1\text{N} = 0.102 \text{ kgf}$   
 $1\text{MPa} = 10.2 \text{ kgf/cm}^2$

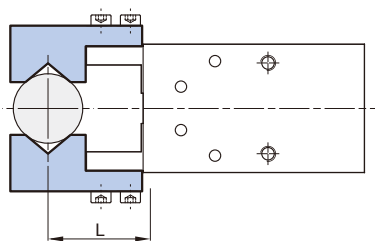

External grip

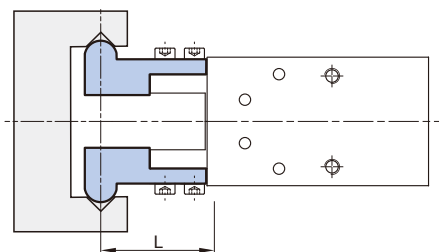

Internal grip

### External gripping force Double acting

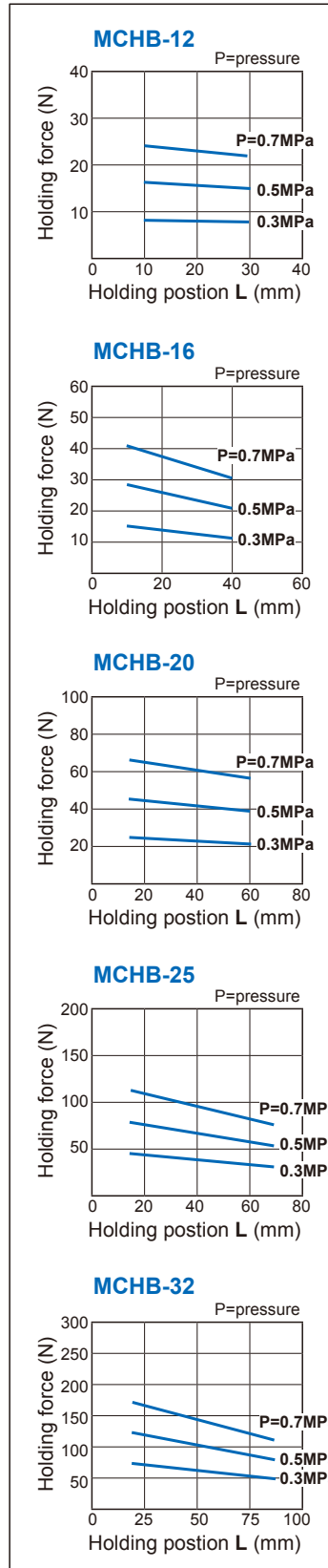

### Internal gripping force Double acting

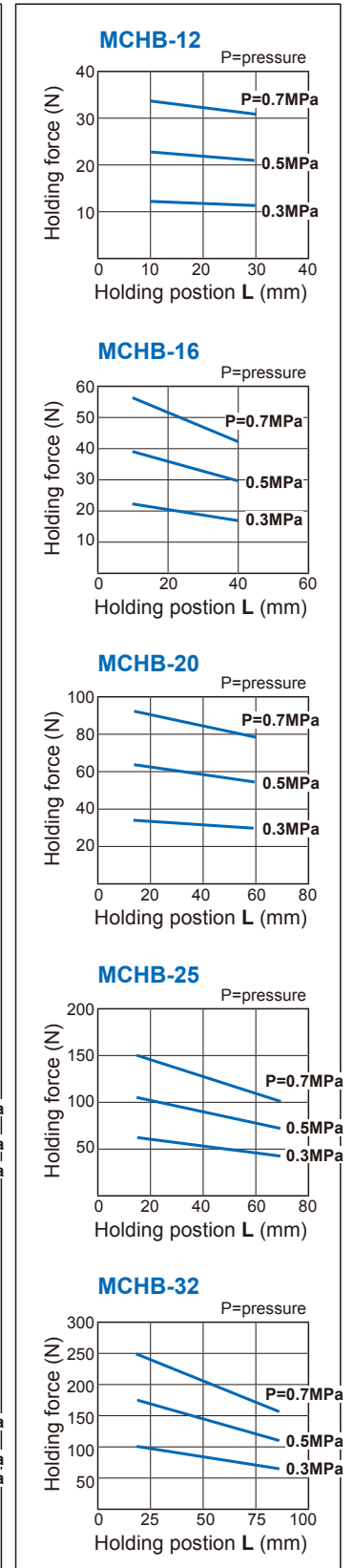

### Effective gripping force (Single acting)

Indication of effective force.

The effective gripping force shown in the graphs to the right is expressed as F, which is the thrust of one finger, when both fingers and attachments are in full contact with the workpiece as shown in the figure below.

1N=0.102 kgf  
1MPa=10.2 kgf/cm<sup>2</sup>

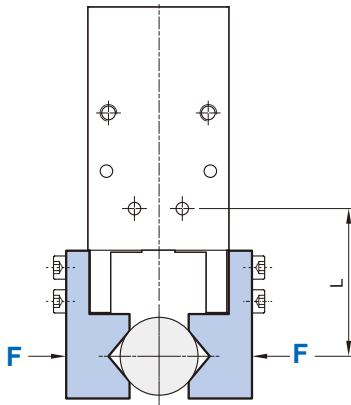

**External grip**  
(Single acting / Normally open)

### External gripping force Single acting / N.O.

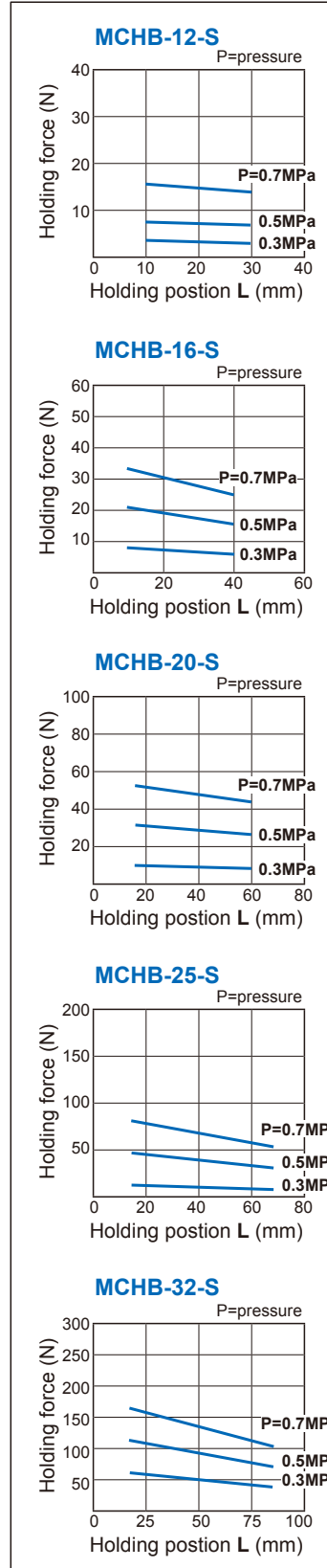

## PARALLEL GRIPPER (2-Finger)

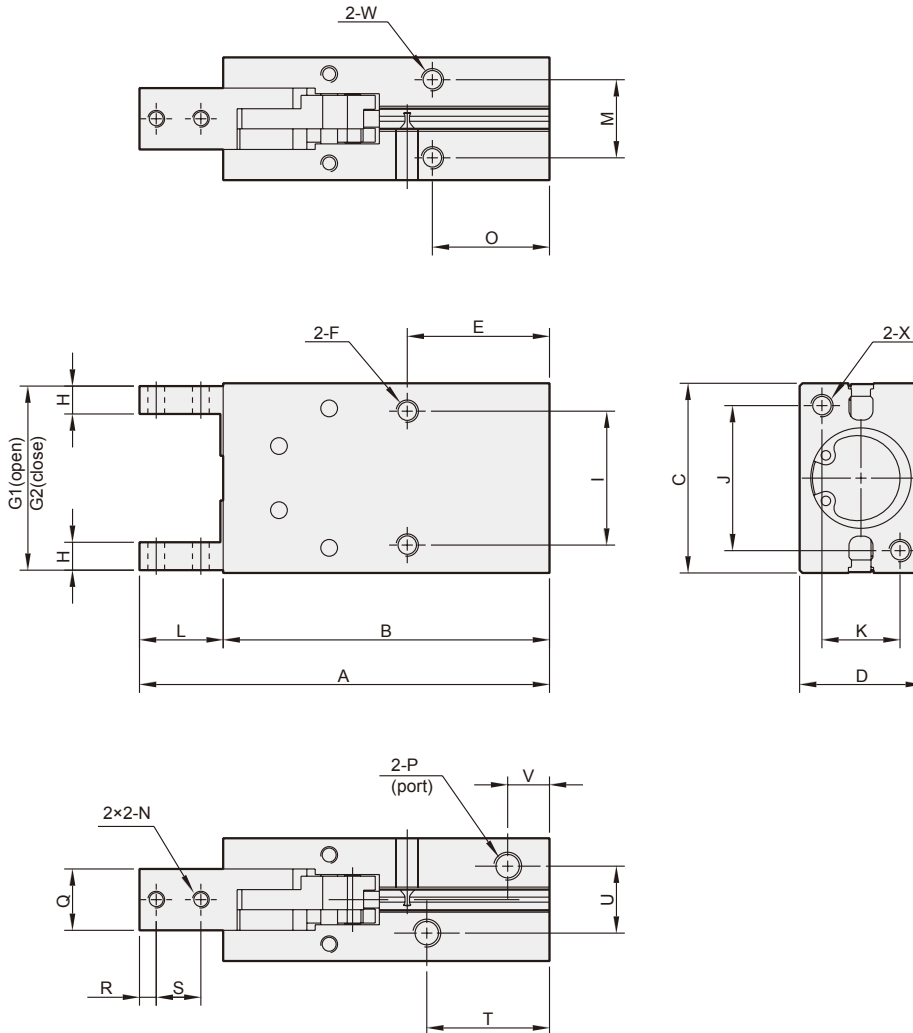

Code Tube I.D.	A	B	C	D	E	F	G1	G2	H	I	J	K	L	M	N	O
12	63.5 (68.5)	50.5 (55.5)	28	16	20 (25)	M3×0.5×5 depth	27	21	4	18	17	10	13	10	M3×0.5	16 (21)
16	73.5 (78.5)	58.5 (63.5)	34	22	25.5 (30.5)	M4×0.7×11 depth	33	25	5	24	26	14	15	14	M3×0.5	21 (26)
20	88.5 (93.5)	69.5 (74.5)	45	26	25 (30)	M5×0.8×8 depth	44	32	6	30	35	16	19	16	M4×0.7	19 (24)
25	102.5 (107.5)	78.5 (83.5)	52	32	28 (33)	M6×1.0×10 depth	51	37	8	36	40	20	24	20	M5×0.8	22 (27)
32	120.5 (125.5)	90.5 (95.5)	60	40	34 (39)	M6×1.0×10 depth	59	43	10	44	46	24	30	26	M6×1.0	26 (31)

Code Tube I.D.	P	Q	R	S	T	U	V	W	X
12	M3×0.5×5 depth	7	3	6	23	10.2	7.5	M3×0.5×5 depth	M3×0.5×5 depth
16	M5×0.8×5 depth	11	3	8	22	12	7.5	M4×0.7×7 depth	M4×0.7×7 depth
20	M5×0.8×5 depth	12	4	10	26	13	8	M5×0.8×8 depth	M5×0.8×8 depth
25	M5×0.8×5 depth	14	5	12	29	18	8.5	M6×1.0×10 depth	M6×1.0×10 depth
32	M5×0.8×5 depth	20	7	15	35	24	10.5	M6×1.0×10 depth	M6×1.0×10 depth

\* Values in ( ) are for single acting.

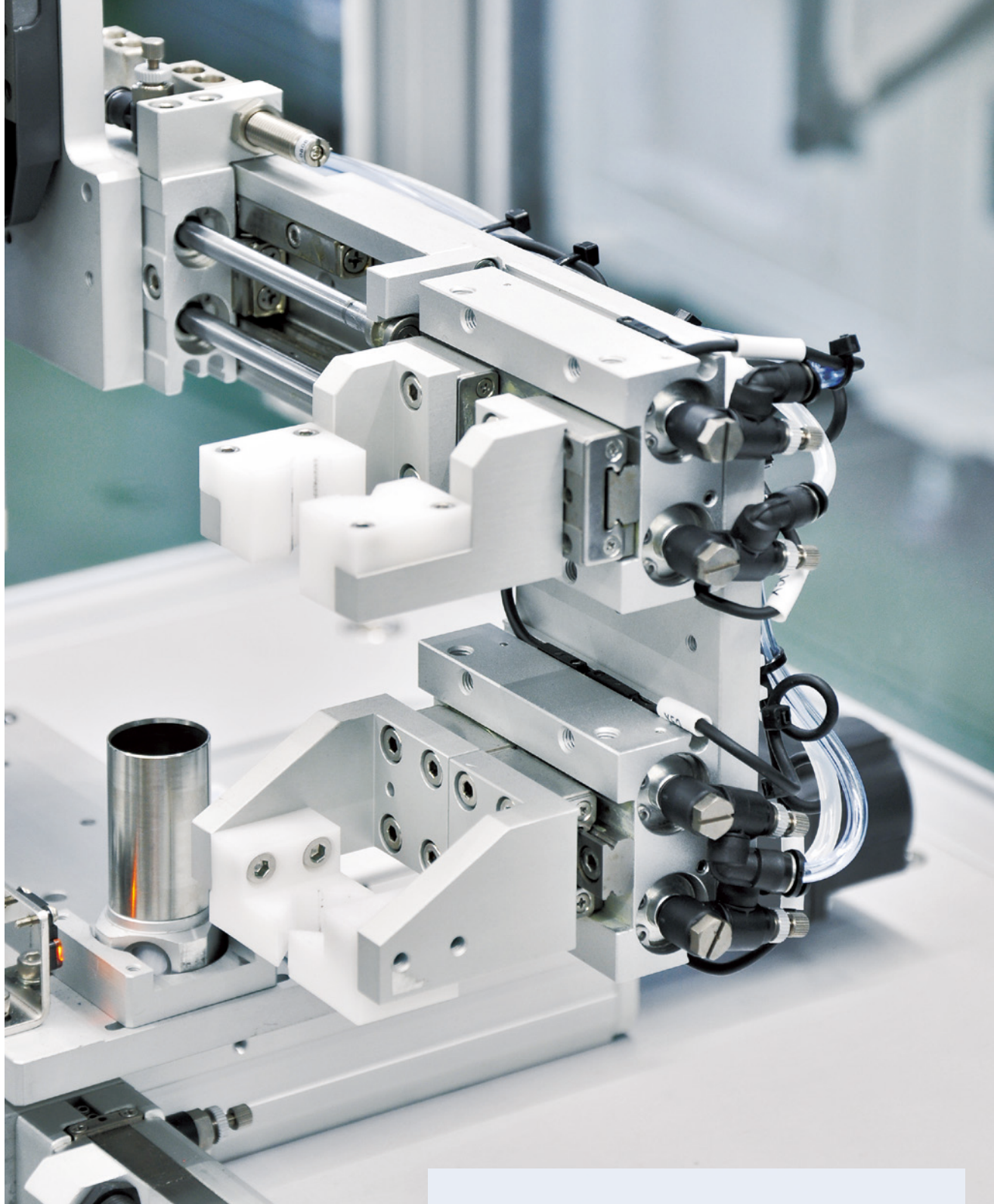

*Connect with*

## *AIR CYLINDER*

Connect gripper with cylinder to achieve regular workpiece gripping.

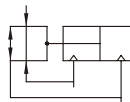

### Order example

MCHD – 20R – □



MODEL TUBE I.D.  
8, 12, 16, 20

STROKE \*  
Blank: Short  
1: Medium  
2: Long

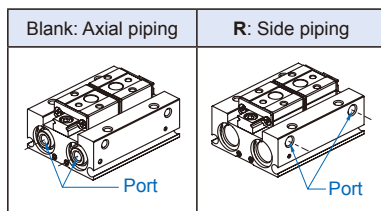
PIPING TYPE

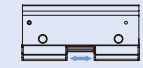

### \* Stroke selection

Tube I.D. Stroke (mm)	8	12	16	20
Short stroke 	8	12	16	20
Medium stroke 	16	24	32	40
Long stroke 	32	48	64	80

### Features

- Low profile design saves space and reduces bending moments, improved accuracy with smooth operation.
- Improved mounting repeatability, easy positioning for mounting.
- Double piston construction achieves compact design with strong gripping force.
- High rigidity and high precision with martensitic stainless steel.
- Grooves on the body for sensor switch to be inserted into.
- Magnetic as standard.

### Specification

Model	MCHD			
Acting type	Double acting			
Tube I.D. (mm)	8	12	16	20
Port size	M3×0.5	M5×0.8		
Medium	Air			
Operating pressure range	0.15~0.7	0.1~0.7 MPa		
Ambient temperature	-10~+60°C (No freezing)			
Repeatability	± 0.05 mm (*1)			
Max. operating frequency (c.p.m)	Short	120		
	Medium	120		
	Long	60		
Lubricator	Not required			
Sensor switch (*2)	2 wire	RDFE(V): Non-contact		
	3 wire	RNFE(V): NPN, RPFE(V): PNP		
Attached bolt	2 pcs	—		

\* 1. This is the value when no offset load is applied to the finger. When an offset load is applied to the finger, the maximum value is ±0.15mm due to the influence of backlash of the rack and pinion.

\* 2. R\*FE(V) specification, please refer to page 90.

### Gripping force

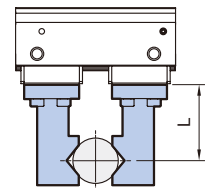

Model	Gripping force per finger effective value (N) (*)	Weight (g)
MCHD-8	19	65
MCHD-8-1		79.1
MCHD-8-2		113.3
MCHD-12	48	150
MCHD-12-1		191.3
MCHD-12-2		291.2
MCHD-16	90	350
MCHD-16-1		454.2
MCHD-16-2		678.3
MCHD-20	141	660
MCHD-20-1		869
MCHD-20-2		1310.6

\* Values based on pressure of 0.5 MPa, gripping point L=20mm, at center of stroke.

### Axial piping

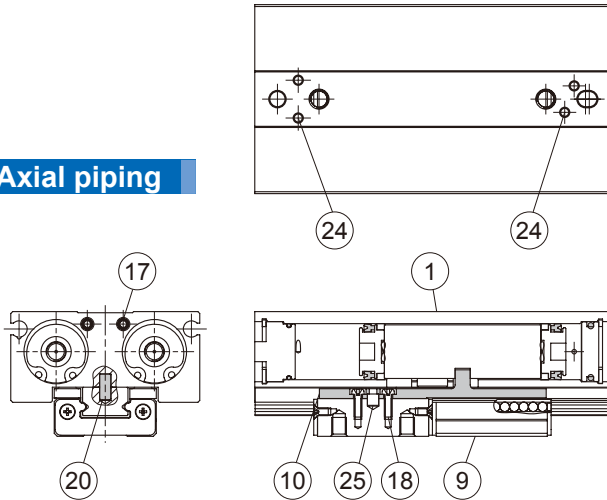

### Side piping

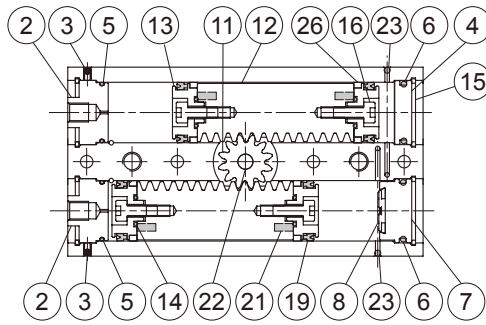
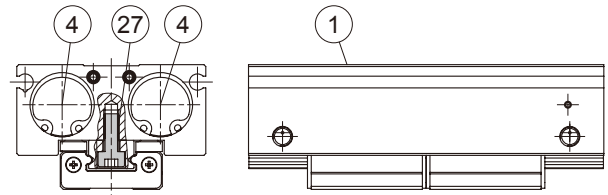

### Order example of repair kits

Tube I.D.	Repair kits	Tube I.D.	Repair kits
ø8	PS-MCHD-8	ø16	PS-MCHD-16
	PS-MCHD-8R		PS-MCHD-16R
ø12	PS-MCHD-12	ø20	PS-MCHD-20
	PS-MCHD-12R		PS-MCHD-20R

### Material

No.	Tube I.D. Part name	Material				Q'y		Repair kits (inclusion)
		8	12	16	20	Axial	Side	
1	Body	Aluminum alloy				1	1	
2	Cover A	Aluminum alloy				2	0	
3	Hexgon screw	Stainless steel				2	0	
4	Cover B	Aluminum alloy				1	3	
5	O-ring	NBR				2	0	●
6	O-ring	NBR				2	4	●
7	Cover C	Aluminum alloy				1	1	
8	Cushion pad	TPU				1	1	●
9	Guide set	Stainless steel				1	1	
10	Lever	Stainless steel				2	2	
11	Pinion	SCM				1	1	
12	Pinion piston	Stainless steel				2	2	
13	Piston	*1	Aluminum alloy			4	2	
14	O-ring	NBR				4	4	●
15	Snap ring	Stainless steel				4	4	
16	Bolt	-	Stainless steel			4	4	
17	Screw	Stainless steel				4	4	
18	Screw	Stainless steel				4	4	

No.	Tube I.D. Part name	Material				Q'y		Repair kits (inclusion)
		8	12	16	20	Axial	Side	
19	Piston packing	NBR				4	4	●
20	Pin	Stainless steel				2	2	
21	Magnet	Magnet material				4	4	
22	Needle	Stainless steel				1	1	
23	Ball	Stainless steel				2	2	
24	Ball	Stainless steel				4	4	
25	Needle	Stainless steel				2	2	
26	Wear ring *2	Resin				4	4	
27	Bolt *3	Stainless steel				K	K	

\*1. Stainless steel

\*2. Model MCHD-8(R)(-1), MCHD-12(R)(-1) without wear ring.

\*3. Bolt Q'y

Model	K
MCHD-8	2
MCHD-8-1	2
MCHD-8-2	4
MCHD-12	2
MCHD-12-1	4
MCHD-12-2	4

Model	K
MCHD-16	2
MCHD-16-1	4
MCHD-16-2	4
MCHD-20	2
MCHD-20-1	4
MCHD-20-2	4

### Model selection

Please select your model according to the weight of workpiece

- Although conditions differ according to the work piece shape and the coefficient of friction between the attachments and the workpiece, select a model that can provide a gripping force of 10 to 20 times the workpiece weight, or more.
- If high acceleration, deceleration or impact forces are encountered during motion, a further margin of safety should be considered.

When gripping a workpiece as in the figure as shown above:

**F**: Gripping force (N)

$\mu$ : Coefficient of friction between the attachments and the workpiece

**m**: Workpiece mass (kg)

**g**: Gravitational acceleration (=9.8m/s<sup>2</sup>)

**mg**: Workpiece weight (N)

the conditions under which the workpiece will not drop are,

$$2 \times \mu F > mg$$

Number of fingers

Therefore,

$$F > \frac{mg}{2 \times \mu}$$

With "a" representing the extra margin, "F" is determined by the following formula:

$$F = \frac{mg}{2 \times \mu} \times a$$

The "10 to 20 times or more of the workpiece weight" is calculated with a safety margin of a=4, which allows for impacts that occur during normal transportation, etc.

$\mu=0.2$	$\mu=0.1$
$F = \frac{mg}{2 \times 0.2} \times 4$	$F = \frac{mg}{2 \times 0.1} \times 4$
$= 10 \times mg$	$= 20 \times mg$
↓	↓
10×workpiece weight	20×workpiece weight

- \* 1. Even in cases where the coefficient of friction is greater than  $\mu=0.2$ , for reasons of safety, please select a gripping force which is at least 10 to 20 times greater than the workpiece weight.
- \* 2. If high acceleration, deceleration or impact forces are encountered during motion, a further margin of safety should be considered.

### Confirmation of external force on fingers

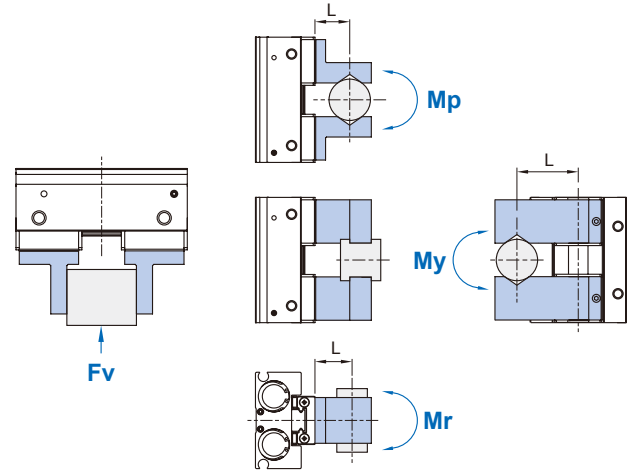

L: Distance to the point at which the load is applied (mm)

Tube I.D. (mm)	Allowable vertical load Fv(N)	Maximum allowable moment		
		Pitch moment Mp(N·m)	Yaw moment My(N·m)	Roll moment Mr(N·m)
8	58	0.26	0.26	0.53
12	98	0.68	0.68	1.4
16	176	1.4	1.4	2.8
20	294	2	2	4

\* Values for load and moment in the table indicate static values.

### Allowable load calculation

$$\text{Allowable load } F(N) = \frac{M(\text{maximum allowable moment})(N \cdot m)}{L(m)}$$

#### Example

When a static load of f=20N is operating, which applies pitch moment to point L=25mm from the MCHD-16 guide.

$$\begin{aligned} \text{Allowable load } F(N) &= \frac{1.4 (N \cdot m)}{25 \times 10^{-3} (m)} \\ &= 56 (N) \end{aligned}$$

Load f=20 (N) < 56 (N), so can be used.

### Model selection example

In the motion process did not produce high acceleration, deceleration or impact forces,  
 Workpiece mass: 300g, Gripping method: External gripping,  
 Operating pressure: 0.5 MPa, Coefficient of friction ( $\mu$ ): 0.1,  
 Holding position: 20mm (no overhang)

1. The conditions under which the workpiece will not drop are,

$$F = \frac{0.3}{2 \times 0.1} \times 4 = 6 \text{ (kgf)} \approx 60 \text{ (N)}$$

2. From Effective Gripping Force Fig,  
 Operating pressure: 0.5 MPa; Holding position: 20 mm  
 Effective gripping force is greater than 60 (N)  
 So selected **MCHD-16** grippers.

### Effective gripping force (Double acting)

Indication of effective force.  
The effective gripping force shown in the graphs to the right is expressed as F, which is the thrust of one finger, when both fingers and attachments are in full contact with the workpiece as shown in the figure below.

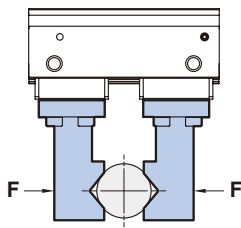

1N=0.102 kgf  
1MPa=10.2 kgf/cm<sup>2</sup>

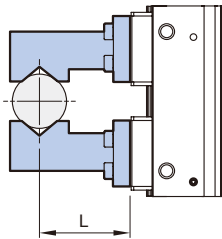

External grip

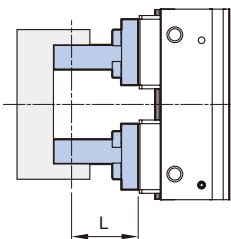

Internal grip

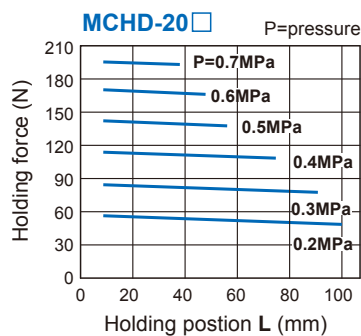
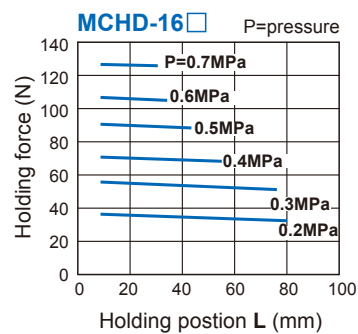
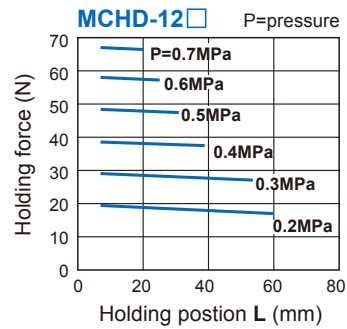
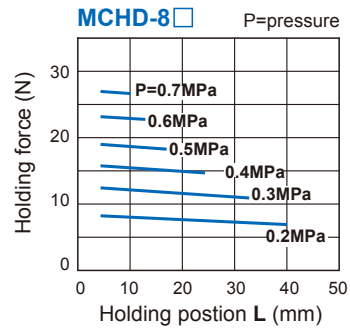

### Confirmation of gripping point

- The air gripper should be operated so that the workpiece gripping point "L" and the amount of overhang "H" stay within the range shown for each operating pressure given in the graphs.
- If the workpiece gripping point goes beyond the range limits, this will have an adverse effect on the life the air gripper.

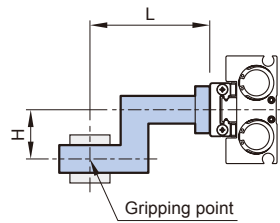

External grip

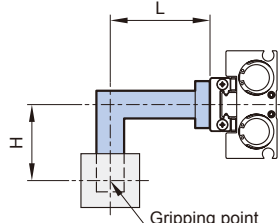

Internal grip

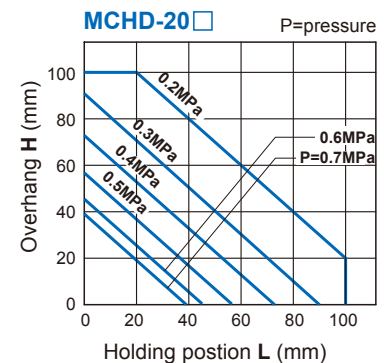
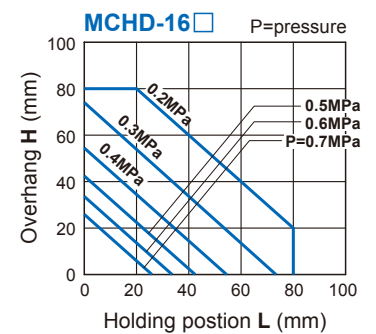
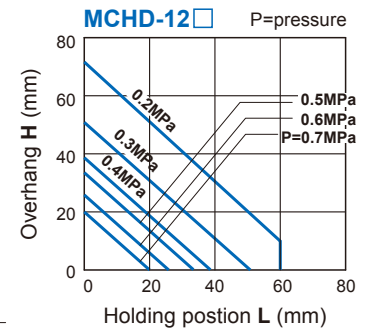
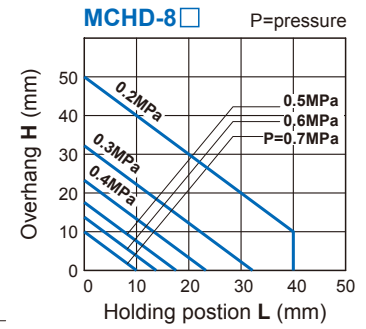

### Product precautions

Before mount the fingers, sure be refer the tightening torque values in the table below.

Tube I.D. (mm)	Bolt	Max. tightening torque (N.m)
8	M2.5×0.45	0.36
12	M3×0.5	0.63
16	M4×0.7	1.5
20	M4×0.7	1.5

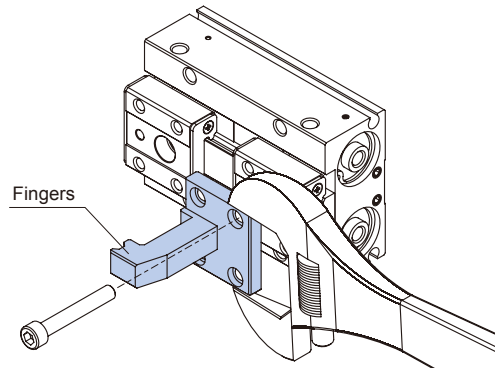

### Order example of attached bolt

\* One set includes 2 pcs, long stroke type need two sets (4 pcs).

#### BOLT — MCHD — 8

ATTACHED BOLT

TUBE I.D.  
8  
12

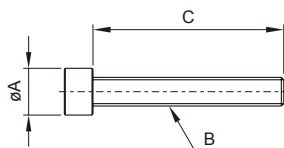

Code Tube I.D.	A	B	C
8	3.8	M2.5×0.45	15
12	4.9	M3×0.5	20

### Installation of sensor switch

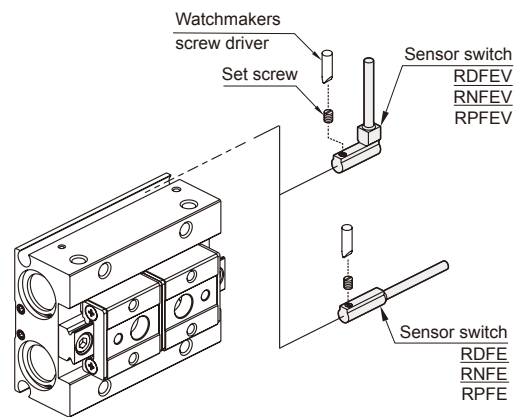

### High degree of mounting flexibility

\* Use the attached bolt for mounting in tube I.D.  $\varnothing 8$ ,  $\varnothing 12$ .

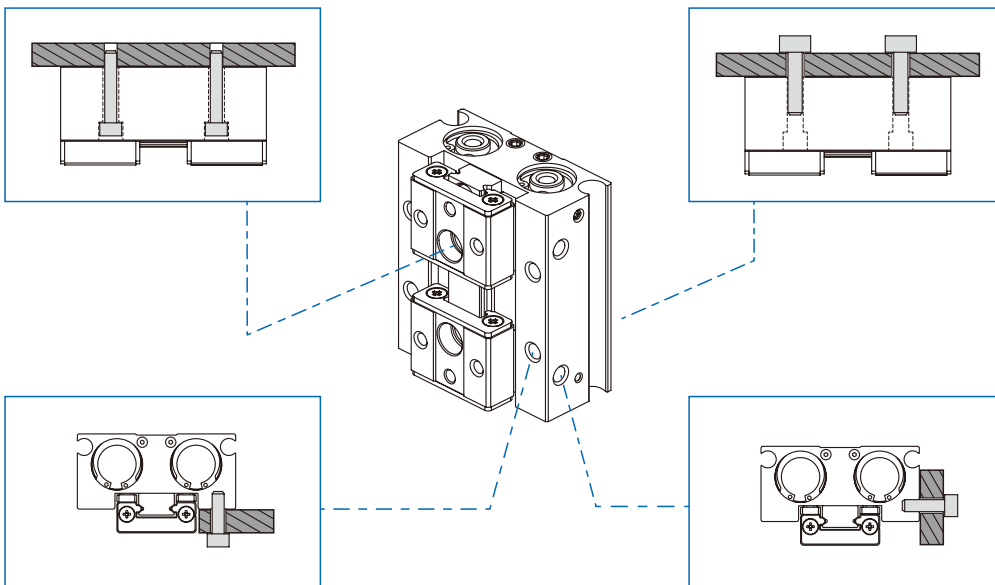

### Axial piping

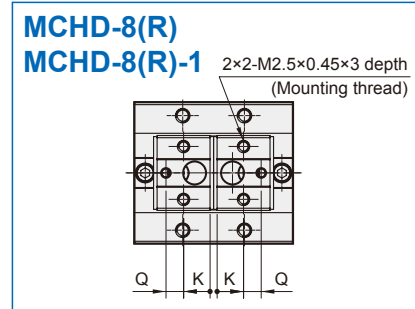
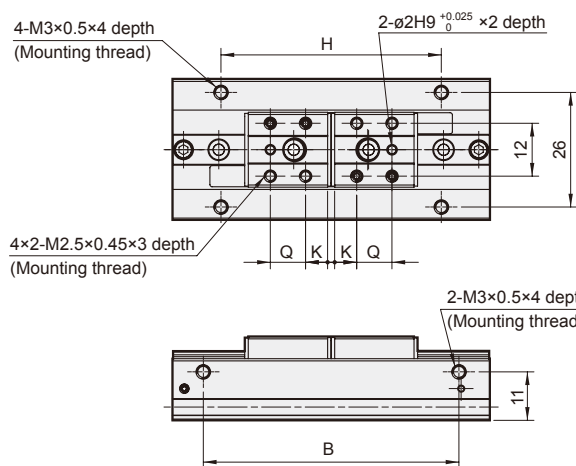
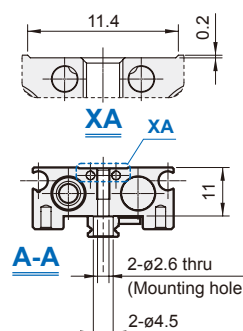
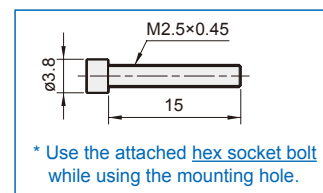
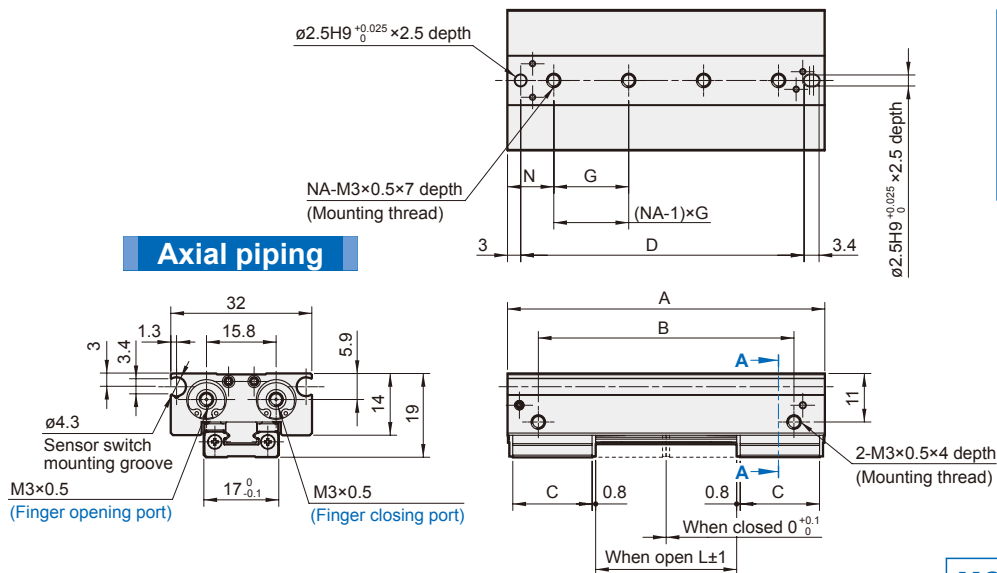

### Side piping

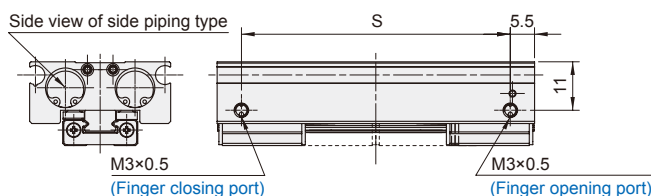

Unit: mm

Code Model	A	B	C	D	G	H	K	L	N	NA	Q	S
MCHD-8(R)	36	22	12	28.3	16	14	6	8	10	2	4	25
MCHD-8(R)-1	48	34	14	40.3	28	26	7	16	10	2	4	37
MCHD-8(R)-2	72	58	18	64.3	17	50	5	32	10.5	4	8	61

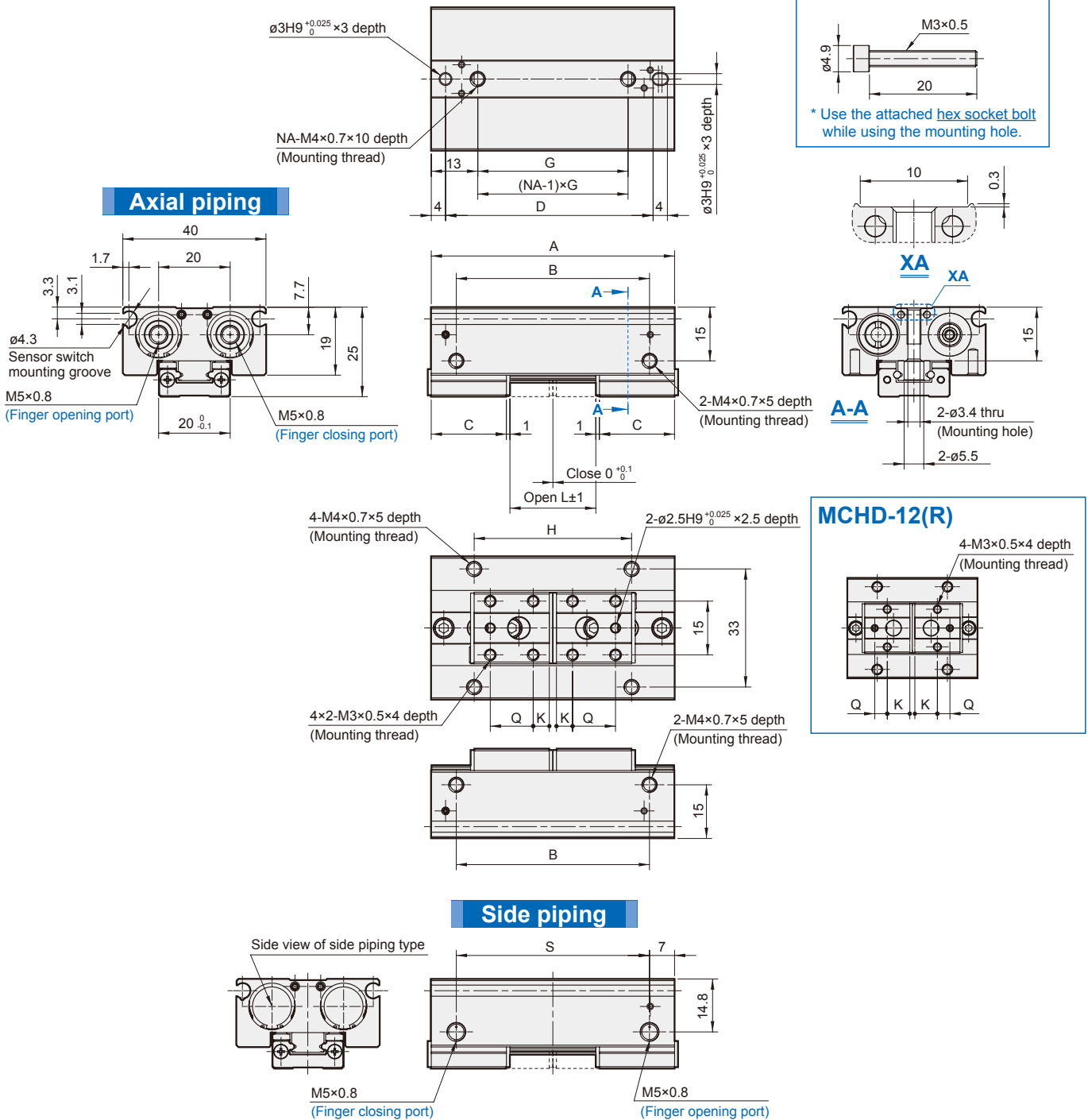

Unit: mm

Code Model	A	B	C	D	G	H	K	L	NA	Q	S
MCHD-12(R)	52	38	18	42	26	28	9	12	2	5	38
MCHD-12(R)-1	68	54	21	58	42	44	4.5	24	2	12	54
MCHD-12(R)-2	104	90	27	94	26	80	4.5	48	4	18	90

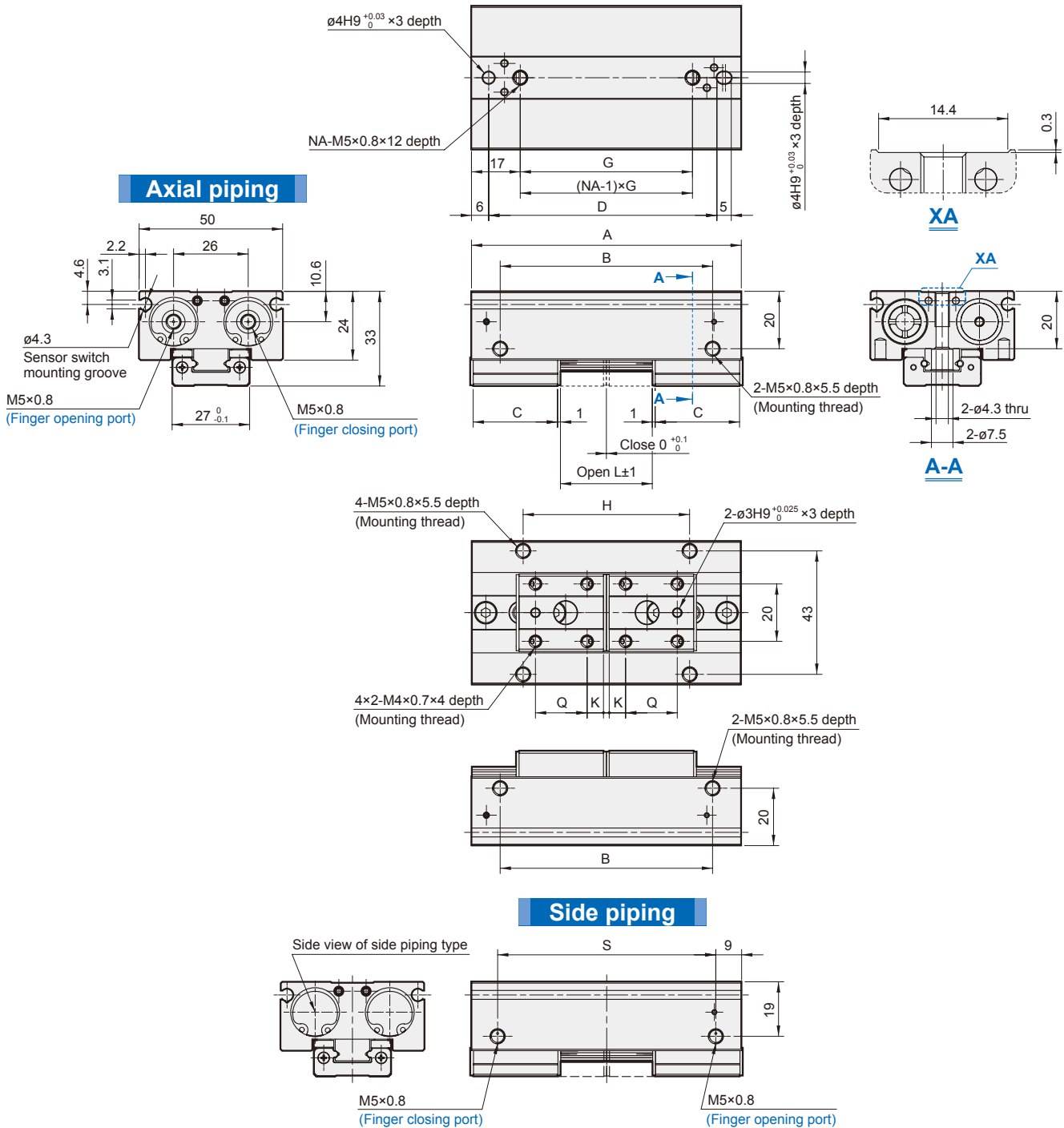

Unit: mm

Code Model	A	B	C	D	G	H	K	L	NA	Q	S
MCHD-16(R)	72	52	25.4	57.5	38	36	5.2	16	2	15	54
MCHD-16(R)-1	94	74	29.4	79.5	60	58	5.7	32	2	18	76
MCHD-16(R)-2	142	122	37.4	127.5	36	106	5.7	64	4	26	124

### Axial piping

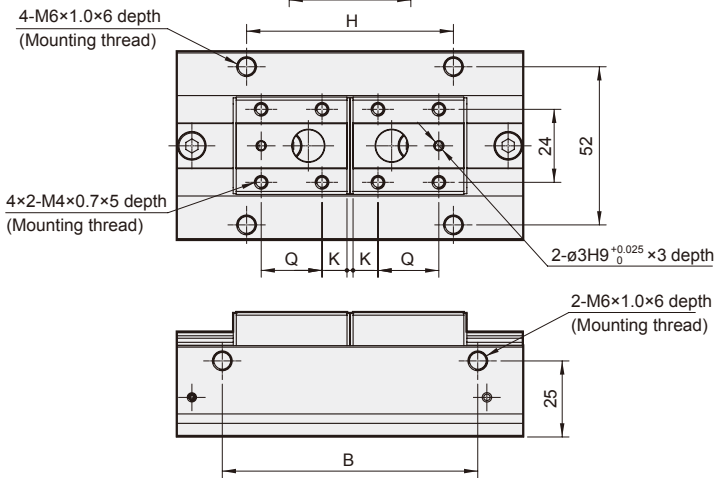
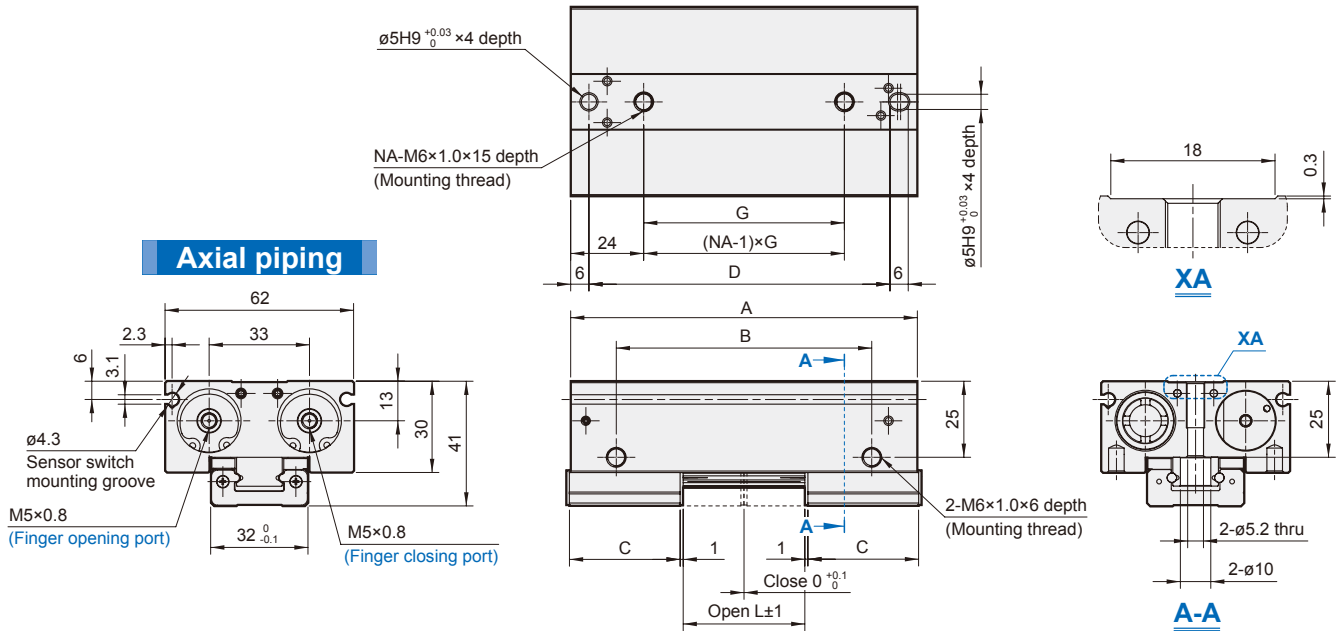

### Side piping

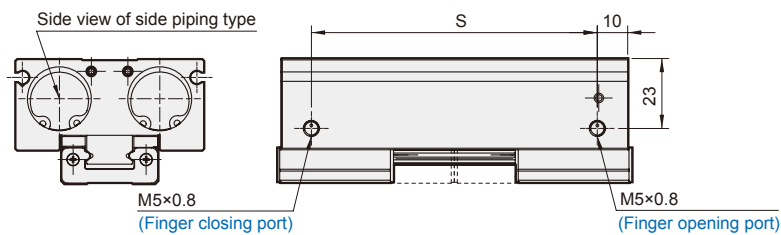

Unit: mm

Code Model	A	B	C	D	G	H	K	L	NA	Q	S
MCHD-20(R)	86	56	31.4	71	38	40	7.7	20	2	16	66
MCHD-20(R)-1	114	84	36.4	99	66	68	8.2	40	2	20	94
MCHD-20(R)-2	174	144	46.4	159	42	128	8.2	80	4	30	154

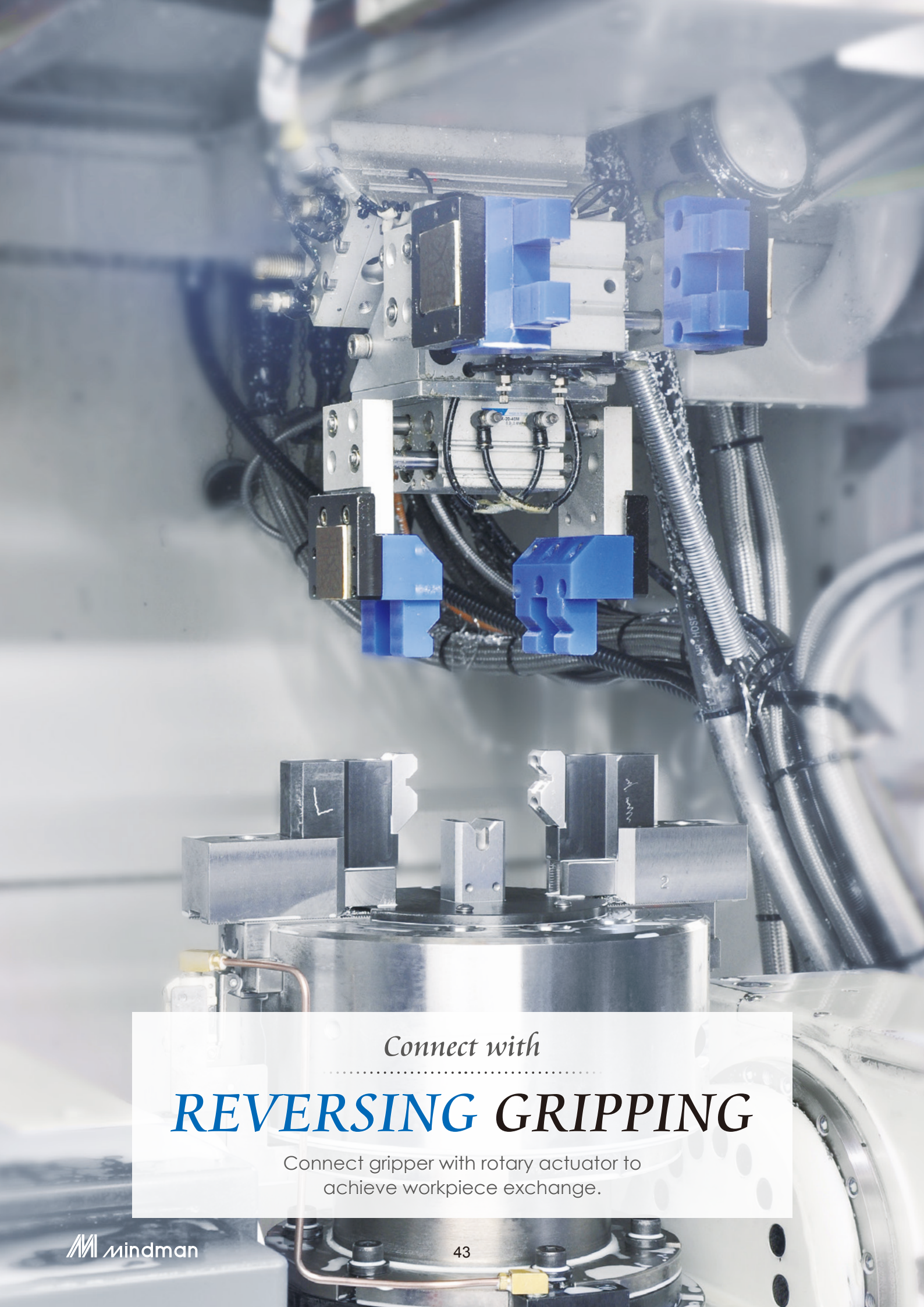

*Connect with*

.....  
**REVERSING GRIPPING**

Connect gripper with rotary actuator to  
achieve workpiece exchange.

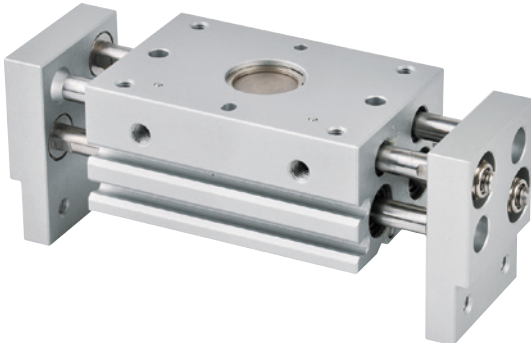

### Features

- Rack and pinion construction enable synchronisation of both jaws enabling smooth and consistent gripping force.
- Wide range of strokes available.
- Dust seals protect all internal parts from ingress of dirt.
- Proximity and reed switches can be used with this unit.
- Magnetic as standard.

### Specification

Model	MCHX					
Acting type	Double acting					
Tube I.D. (mm)	10	16	20	25	32	40
Medium	Air					
Operating pressure range	0.2~0.6 MPa					
Ambient temperature	-5~+60°C (No freezing)					
Lubrication	Not required					
Repeatability	±0.1 mm					
Sensor switch (*)	<b>RDVE(V): Non-contact</b> <b>RNFE(V): NPN, RPFE(V): PNP</b>					

### Order example

**MCHX - 16 - 30 M**

MODEL

TUBE I.D.	STROKE
10	20, 40, 60
16	30, 60, 80
20	40, 80, 100
25	50, 100, 120
32	70, 120, 160
40	100, 160, 200

M: Magnet

\* Magnetic as standard.

\* R\*FE(V) specification, please refer to page 90.

### Weight

Model	MCHX-10			MCHX-16			MCHX-20			MCHX-25			MCHX-32			MCHX-40		
Stroke (mm)	20	40	60	30	60	80	40	80	100	50	100	120	70	120	160	100	160	200
Max. operating frequency (c.p.m)	60	40	40	60	40	40	60	40	40	60	40	40	30	20	20	30	20	20
Weight (kg)	0.28	0.35	0.44	0.56	0.8	0.94	1.0	1.5	1.68	1.69	2.8	3.0	3.15	4.36	5.02	5.3	6.8	8.6

### Mounting

#### Axial mounting

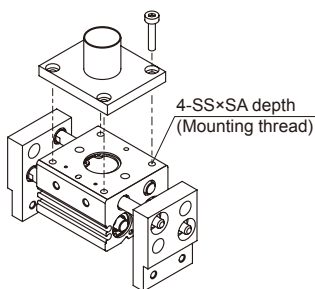

Tube I.D.	SA	SS	Max. tightening torque (N.m)
10	8	M4×0.7	2.1
16	10	M5×0.8	4.3
20	12	M6×1.0	7.3
25	16	M8×1.25	17.7
32	16	M8×1.25	18
40	20	M10×1.5	36

#### Axial mounting

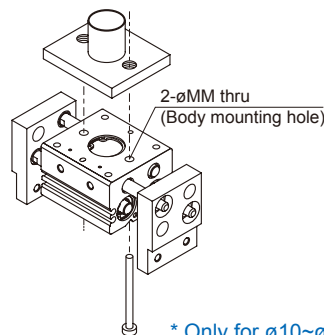

\* Only for ø10~ø25.

Tube I.D.	MM	Bolt	Max. tightening torque (N.m)
10	4.5	M4×0.7	2.1
16	5.5	M5×0.8	4.3
20	6.6	M6×1.0	7.3
25	9	M8×1.25	17.7
32	-	-	-
40	-	-	-

#### Lateral mounting

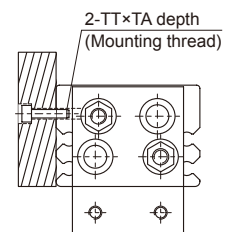

Tube I.D.	TA	TT	Max. tightening torque (N.m)
10	5	M4×0.7	1.4
16	7	M5×0.8	2.8
20	7	M6×1.0	4.8
25	7	M8×1.25	12
32	11	M8×1.25	12
40	12	M10×1.5	24

ø10

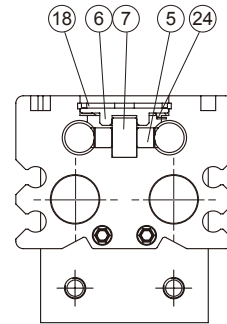
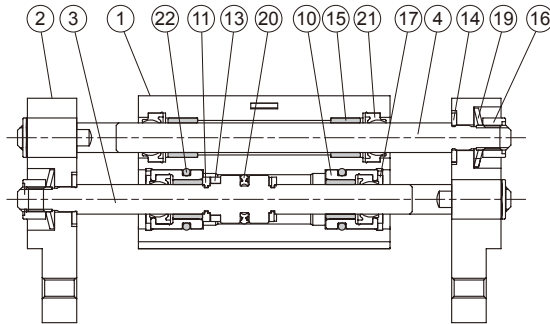

ø16~ø40

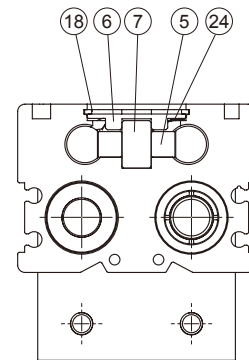
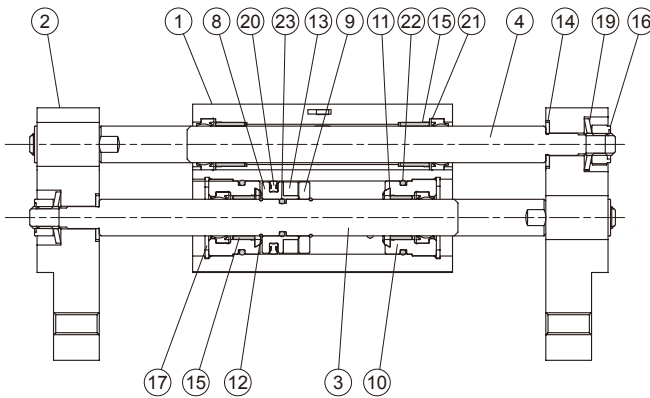

### Material

No.	Tube I.D. Part name	10	16	20	25	32	40	Q'y	Repair kits (inclusion)
1	Body	Aluminum alloy						1	
2	Finger	Aluminum alloy						2	
3	Piston rod	Stainless steel						2	
4	Rack	Stainless steel						2	
5	Pinion	Carbon steel						1	
6	Pinion cover	Carbon steel						1	
7	Pinion axis	Stainless steel						1	
8	Piston	–	Brass				2		
9	Magnet holder	–	Brass				2		
10	Rod cover	Aluminum alloy						4	
11	Damper	NBR	PU	NBR			4	●	
12	Stop ring	–	Spring steel	*1	*2		4		
13	Magnet	Magnet material						2	
14	Washer	Stainless steel			Carbon steel			4	
15	Bearing	Oil containing polyacetal with back metal						8	
16	U nut	Carbon steel						4	
17	R-shape snap ring	*3	*1	Carbon steel		*1	4		
18	C-shape snap ring	Carbon steel						1	
19	Conical spring washer	Stainless steel *4						4	
20	Piston packing	NBR						2	●
21	Rod packing	NBR						8	●
22	O-ring	NBR						4	●
23	O-ring	–	NBR				2		
24	Wave washer	Carbon steel						1	

### Order example of repair kits

Tube I.D.	Repair kits
ø10	<b>PS-MCHX-10</b>
ø16	<b>PS-MCHX-16</b>
ø20	<b>PS-MCHX-20</b>
ø25	<b>PS-MCHX-25</b>
ø32	<b>PS-MCHX-32</b>
ø40	<b>PS-MCHX-40</b>

\*1. Stainless steel

\*2. Spring steel

\*3. Carbon steel

\*4. ø40: Stainless steel 2 pcs + Carbon steel 2 pcs

### Model selection example

\* Finger selection please refer to page 6.

In the motion process did not produce high acceleration, deceleration or impact forces, Workpiece mass: 0.3kg , Gripping method: External gripping, Operating pressure: 0.5 MPa, Coefficient of friction ( $\mu$ ): 0.1, Holding position: L=20mm (no overhang)

- Based on the above formula, the required gripping force can be derived:
 
$$F \geq \frac{0.3 \times 9.8}{2 \times 0.1} \times 4 \geq 60(N)$$
- From Effective Gripping Force Fig. Operating pressure: 0.5 MPa; Holding position: 20 mm Effective gripping force is greater than 60 (N) So selected **MCHX-20-40** grippers.

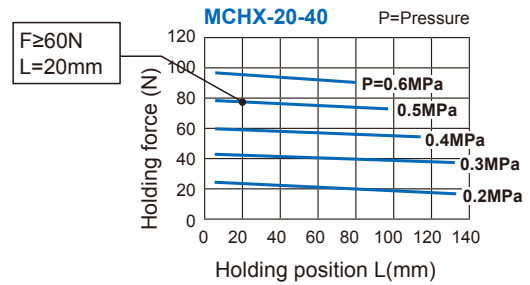

### Model selection suggestions

- For normal gripping and carrying usage, the recommended safe factor (a) is 4.
- The value of gripping force of single finger can be found at the gripping force table.
- The safe factor (a) have to be higher if the gripper is using with a great accelerated velocity or impaction condition.

### Mounting precautions

- To prevent bending the piston rod, please mount the attachment when finger is closing.
- Do not scratch or dent the sliding portion of the piston rod, or it may cause air leaks or faulty operation.
- Refer to the table below for the proper tightening torque on the bolt used for securing the attachment to the finger.

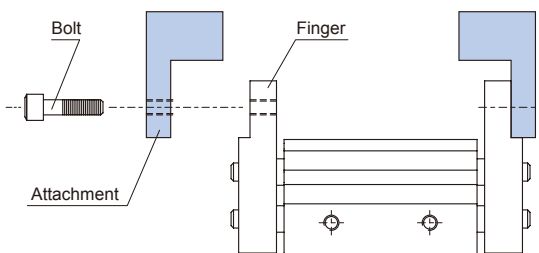

Tube I.D.	Bolt	Max. tightening torque (N.m)
10	M4×0.7	1.4
16	M5×0.8	2.8
20	M6×1.0	4.8
25	M8×1.25	12
32	M10×1.5	24
40	M12×1.75	42.2

### Applications

Connect with rotary actuator to rotate workpiece in a automatic manufacture line.

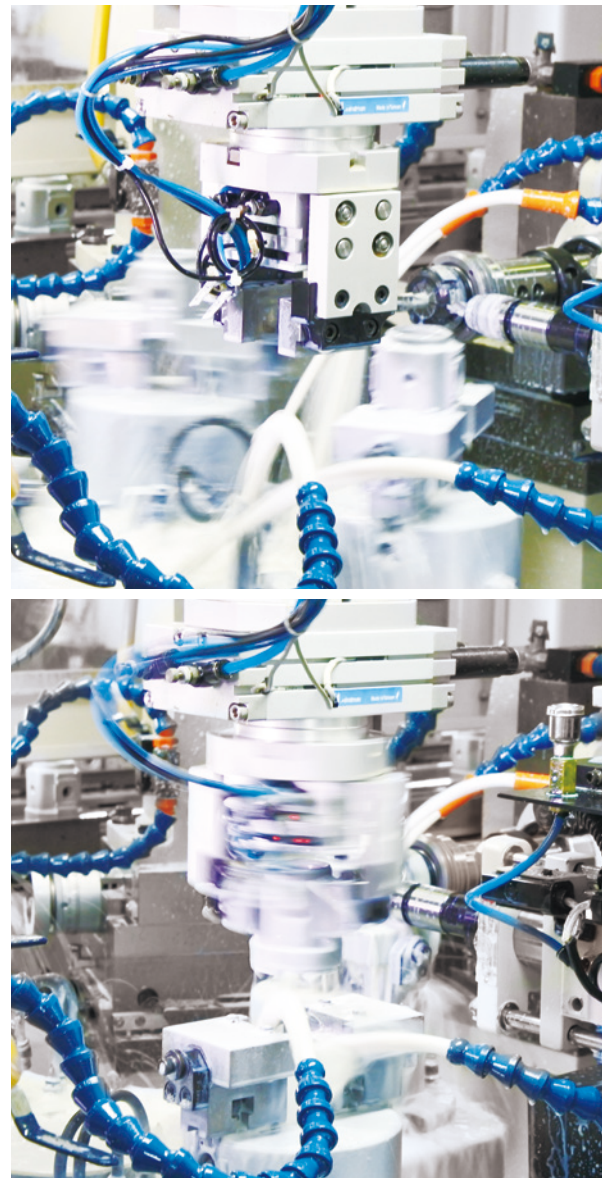

### Effective gripping force

Indication of effective force.

The effective gripping force shown in the graphs to the right is expressed as F, which is the thrust of one finger, when both fingers and attachments are in full contact with the workpiece as shown in the figure below.

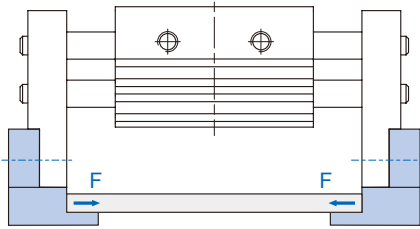

1N=0.102 kgf  
1MPa=10.2 kgf/cm<sup>2</sup>

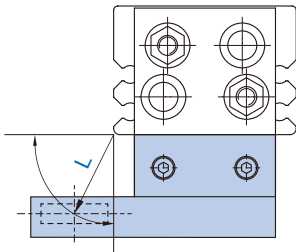

L: Holder position (mm)

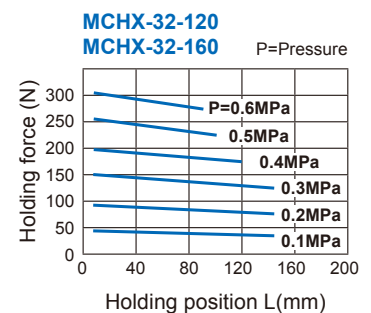
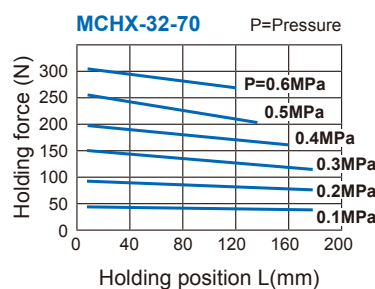
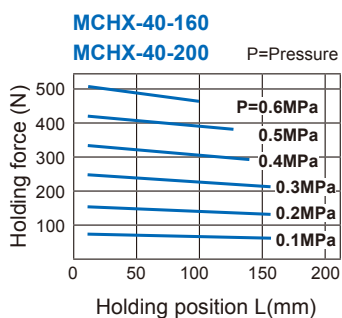
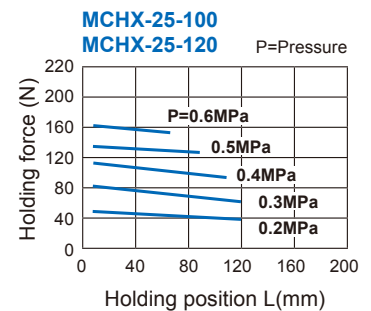
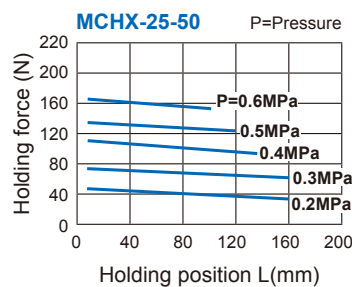
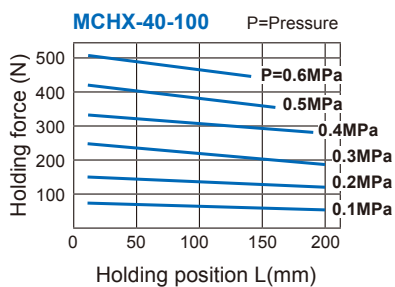
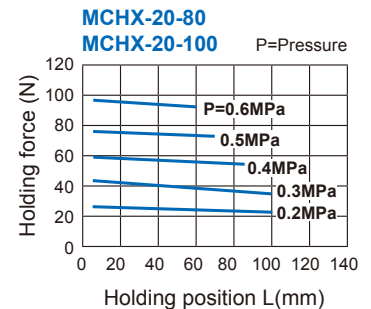
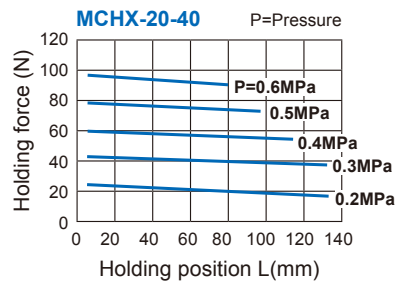
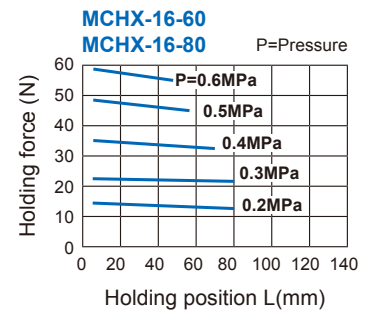
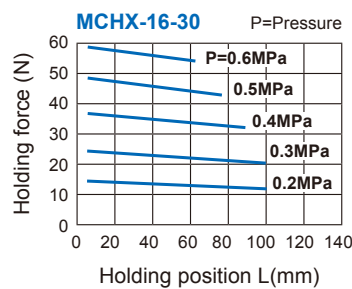
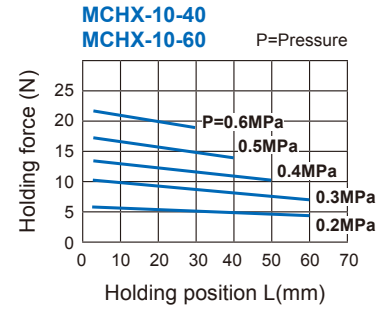
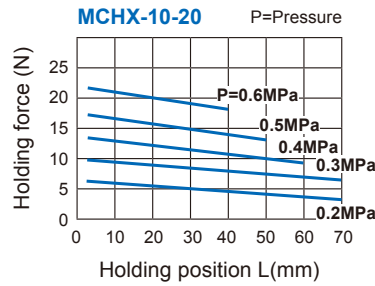

## WIDE TYPE PARALLEL GRIPPER (2-Finger)

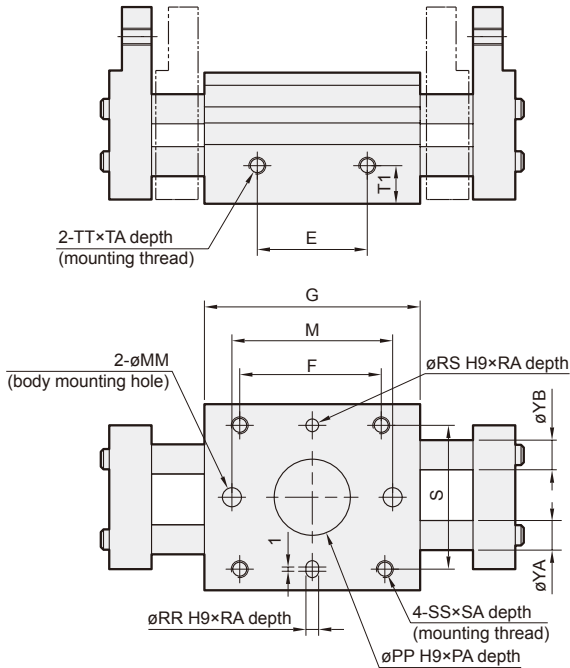

Code Tube I.D.	Stroke	A	B	DA	DB	E	F	G	M	P1	P2
10	20	76	56	100	80	26	36	51	38	11.5	11.5
	40	118	78	142	108	42	52	67	54	19.5	19.5
	60	156	96	180	146	60	70	85	72	28.5	28.5
16	30	98	68	128	98	28	45	60	40	13	13
	60	170	110	200	152	58	75	90	70	25	25
	80	210	130	240	192	78	95	110	90	35	35
20	40	122	82	160	120	38	58	71	54	16	16
	80	222	142	260	194	80	100	113	96	34	34
	100	262	162	300	234	100	120	133	116	44	44
25	50	150	100	196	146	48	70	88	66	19	19
	100	282	182	328	244	102	124	142	120	43	43
	120	320	200	366	282	120	142	160	138	52	52
32	70	220	150	272	202	60	86	110	—	28	28
	120	318	198	370	282	108	134	158	—	52	52
	160	402	242	454	366	152	178	202	—	74	74
40	100	288	188	348	252	80	116	148	—	36	36
	160	406	246	466	370	138	174	206	—	65	65
	200	486	286	546	450	178	214	246	—	85	85

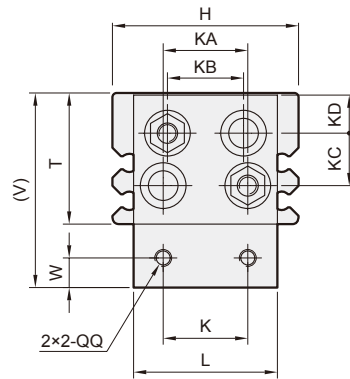
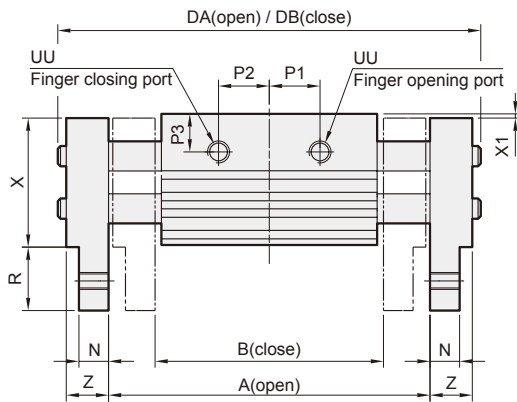

Code Tube I.D.	H	K	KA	KB	KC	KD	L	N	MM	PA	PP	P3	QQ	R	RA	RR	RS	S	SA	SS
10	44	20	20	18.2	12.5	8	34	7	4.5	1.5	18	9	M4×0.7	15	3	3	3	34	8	M4×0.7
16	55	25	25	22.6	16.5	9	43	9	5.5	1.5	23	10	M5×0.8	19	3	3	3	42	10	M5×0.8
20	65	30	30	28.2	20	10	54	12.5	6.6	1.5	24	11	M6×1.0	24	4	4	4	52	12	M6×1.0
25	76	40	38	33.2	23.5	11.5	64	14	9	1.5	32	16	M8×1.25	29	4.5	4	4	62	16	M8×1.25
32	82	50	40	32.2	30	14.5	70	15	—	2.5	35	16	M10×1.5	32	8	6	6	64	16	M8×1.25
40	98	60	48	40.2	37	16	86	18	—	2.5	40	18	M12×1.75	38	8	6	6	76	20	M10×1.5

Code Tube I.D.	T	T1	TA	TT	UU	V	W	X	X1	YA	YB	Z
10	31	9	5	M4×0.7	M5×0.8	46	7	30.5	0.5	6	6	10
16	39	10	7	M5×0.8	M5×0.8	58	8	38.5	0.5	8	8	13
20	46	11	7	M6×1.0	M5×0.8	70	10	45	1	10	10	17
25	52	12.5	7	M8×1.25	M5×0.8	81	12	51	1	12	12	21
32	68	22	11	M8×1.25	Rc1/8	100	15	67	1	14	16	24
40	79	28	12	M10×1.5	Rc1/8	117	18	78	1	16	20	28

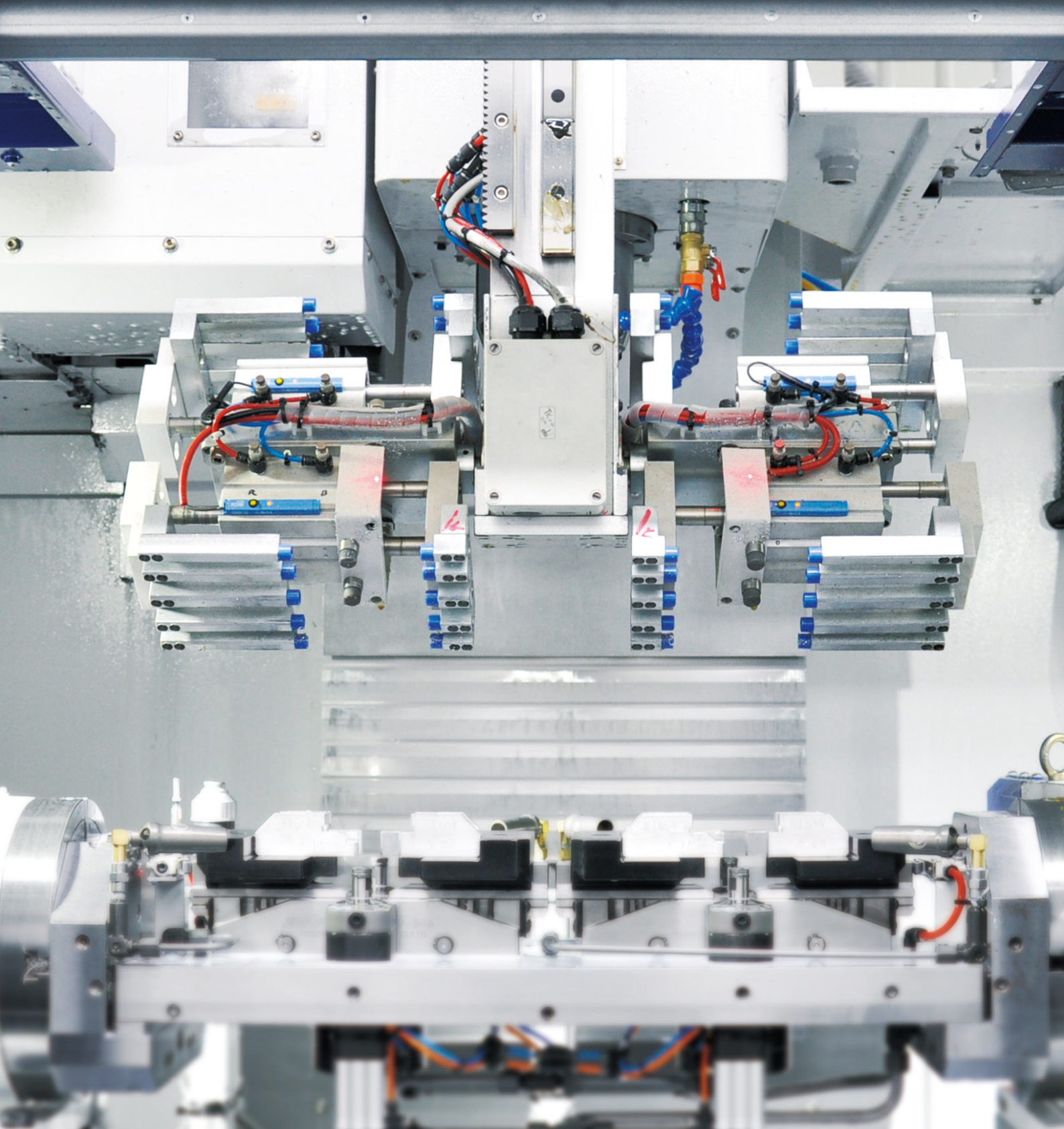

*Connect with*

.....  
***MACHINE TOOL***

Connect gripper with machine tool to manufacture.



*Connect with*



**AUTOMATIC  
ASSEMBLY  
MACHINE**

Connect gripper with cylinder to achieve regular workpiece gripping.



### Order example

**MCHH – 25 M**

MODEL

TUBE I.D.

M: Magnet

20  
25  
40

\* Magnetic as standard.

### Features

- With the same tube I.D., the gripping stroke is longer compare with other grippers.
- The plain bearing parts are hardened for longer effective life time.
- Three mounting directions are available.
- Magnetic as standard.

### Specification

Model	MCHH		
Acting type	Double acting		
Tube I.D. (mm)	20	25	40
Stroke	16	26	41
Medium	Air		
Operating pressure range	0.3~0.7 MPa		
Ambient temperature	-10~+60°C (No freezing)		
Lubrication (*1)	Not required		
Repeatability	± 0.03 mm		
Max. operating frequency	60 c.p.m		
Sensor switch (*2)	2 wire	<b>RDFE(V)</b> : Non-contact	
	3 wire	<b>RNFE(V)</b> : NPN, <b>RPFE(V)</b> : PNP	
Weight (kg)	0.27	0.59	1.46

\*1. Sliding area of jaws need scheduled relubrication.

\*2. R\*FE(V) specification, please refer to page 90.

### Load limit

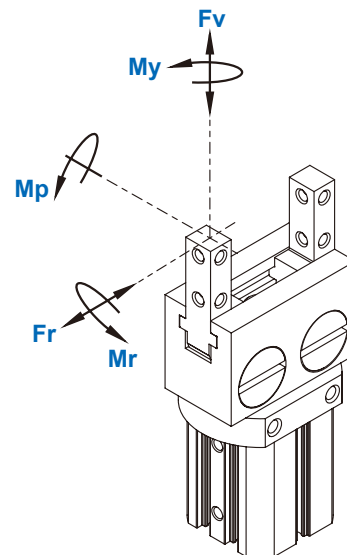

### Installation of sensor switch

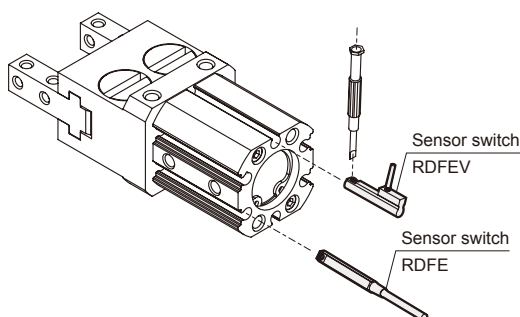

Code Tube I.D.	Mr max. (Nm)	Mp max. (Nm)	My max. (Nm)	Fv max. (N)	Fr max. (N)
<b>20</b>	0.83	0.41	0.41	56.55	37.70
<b>25</b>	1.56	0.78	0.78	80.86	53.91
<b>40</b>	9.17	4.58	4.58	371.56	247.71

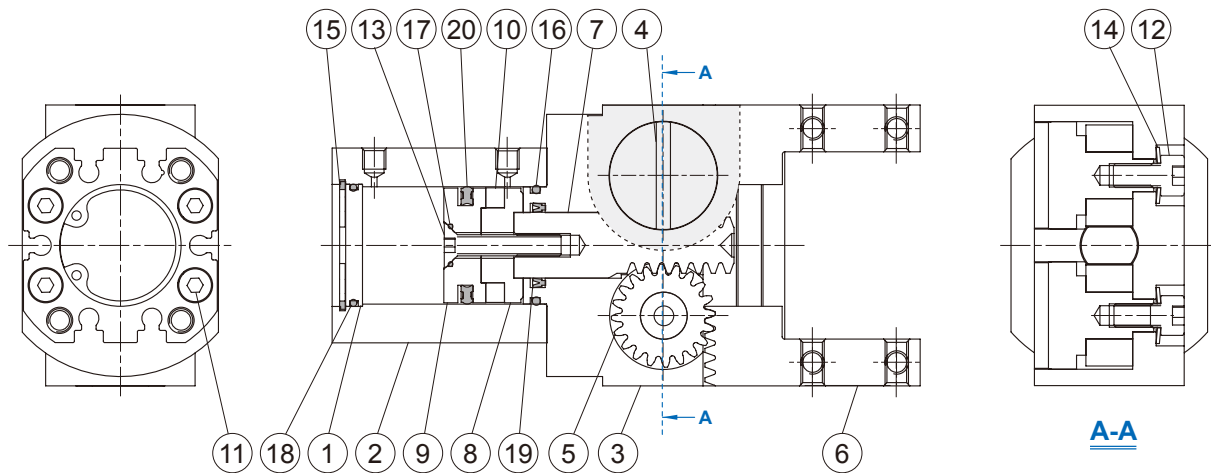

### Material

No.	Part name	Material	Q'y	Repair kits (inclusion)
1	End cover	Aluminum alloy	1	
2	Body	Aluminum alloy	1	
3	Finger rail	Aluminum alloy	1	
4	Pinion holder	Carbon steel	2	
5	Pinion	Alloy steel	2	
6	Finger	Alloy steel	2	
7	Piston rod	Alloy steel	1	
8	Magnet holder	Aluminum alloy	1	
9	Piston	Aluminum alloy	1	
10	Magnet ring	Magnet material	1	
11	Hexgon bolt (*)	Steel	2 or 4	
12	Hexgon bolt	Steel	2	
13	Countersink bolt	Steel	1	
14	Washer	Spring steel	2	
15	Snap ring	Spring steel	1	
16	O-ring	NBR	1	●
17	O-ring	NBR	1	●
18	O-ring	NBR	1	●
19	Rod packing	NBR	1	●
20	Piston packing	NBR	1	●

\* ø20 Q'y: 2 pcs, ø25 & ø40 Q'y: 4 pcs

### Order example of repair kits

Tube I.D.	Repair kits
ø20	<b>PS-MCHH-20</b>
ø25	<b>PS-MCHH-25</b>
ø40	<b>PS-MCHH-40</b>

### Effective gripping force

Indication of effective force.

The effective gripping force shown in the graphs to the right is expressed as F, which is the thrust of one finger, when both fingers and attachments are in full contact with the workpiece as shown in the figure below.

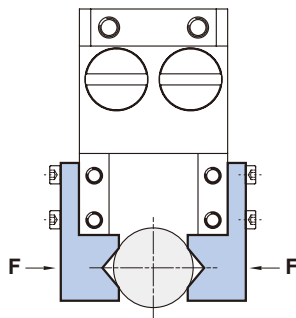

1N=0.102 kgf  
1MPa=10.2 kgf/cm<sup>2</sup>

### External grip

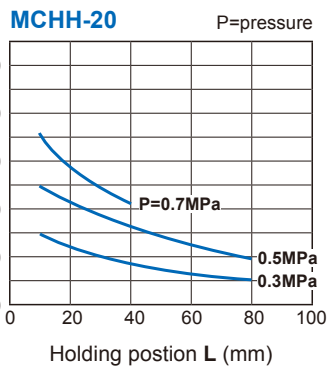

### Internal grip

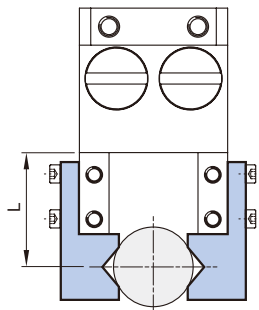
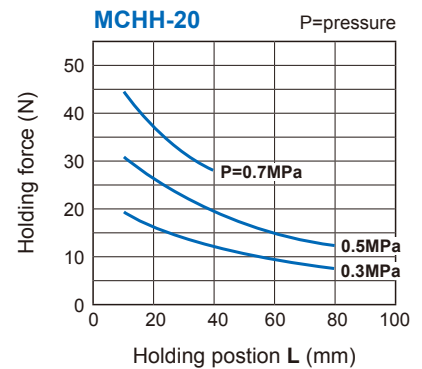

External grip

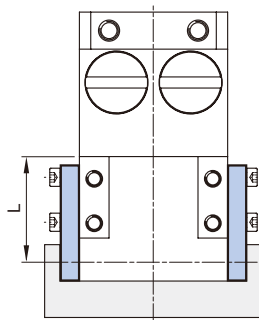
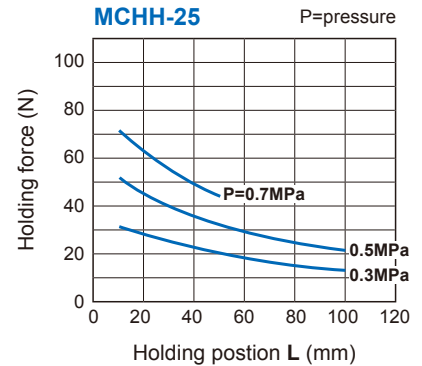
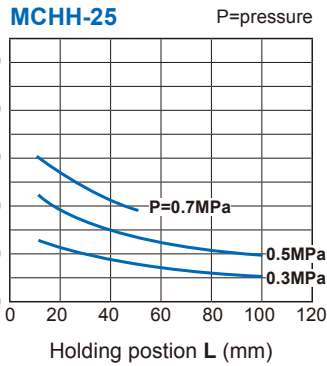

Internal grip

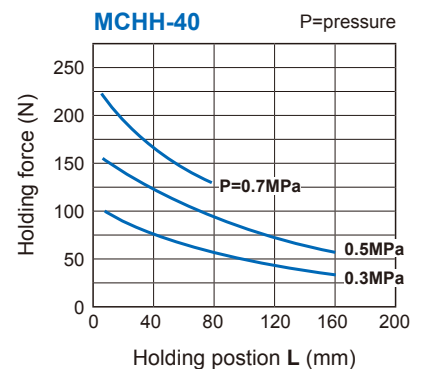
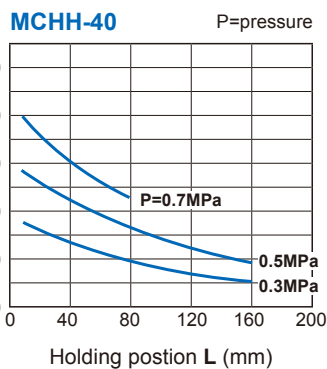

## PARALLEL GRIPPER (2-Finger)

### $\phi 20$

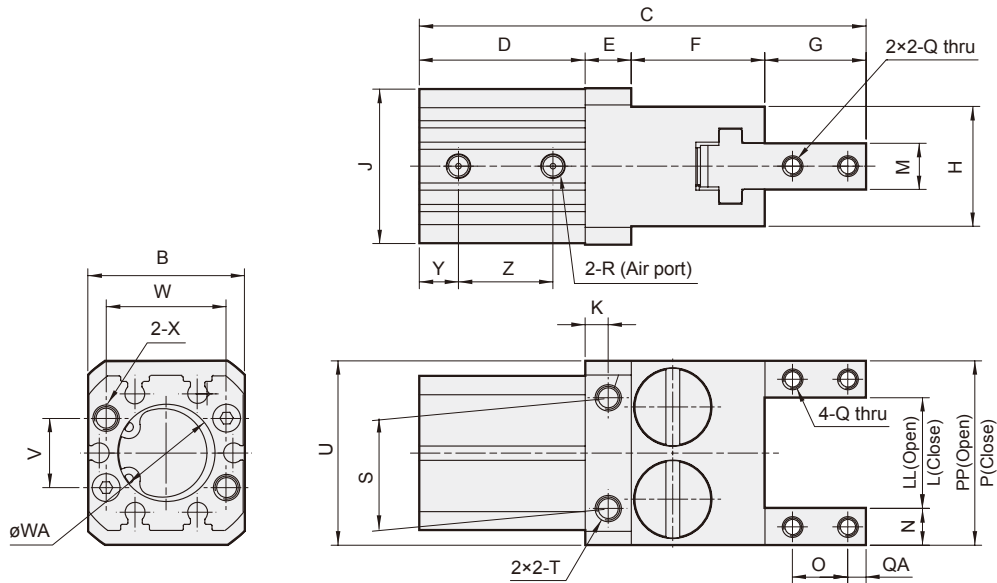

### $\phi 25, \phi 40$

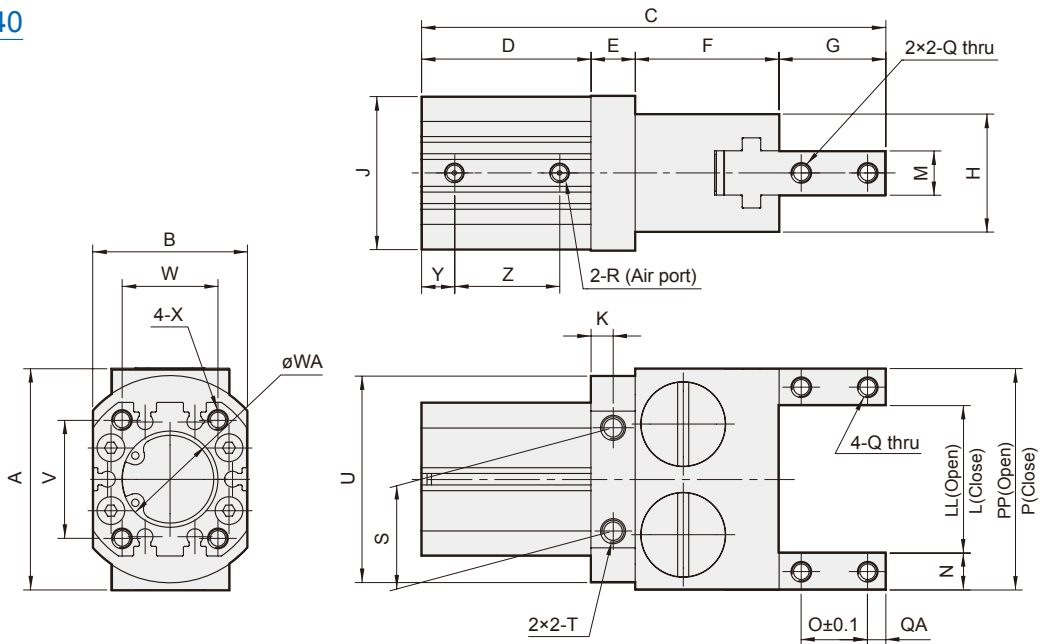

Code Model	A	B	C	D	E	F	G	H	J	K	L	LL	M	N	O	P	PP	Q	QA	R	S	T	U
MCHH-20	-	34	97	36	10	29	22	26	33.5	5	8	24	10 <sup>-0.01/-0.06</sup>	8	12	24	40	M4×0.7	4	M5×0.8	24	M5×0.8×12 dp	40
MCHH-25	60	42	126	46	12	39	29	32	41.5	6	14	40	12 <sup>-0.01/-0.06</sup>	10	18	34	60	M5×0.8	5	M5×0.8	28	M6×1.0×14 dp	$\phi 56$
MCHH-40	92	60	167	57	15	58	37	38	58	8	26	68	14 <sup>-0.01/-0.06</sup>	12	20	50	92	M6×1.0	7	Rc1/8	42	M8×1.25×14 dp	$\phi 82$

Code Model	V	W	WA	X	Y	Z
MCHH-20	15	26	$\phi 22^{+0.05}_0 \times 1.5$ dp	M5×0.8×10 dp	8.5	20.5
MCHH-25	32	26	$\phi 26^{+0.05}_0 \times 1.5$ dp	M5×0.8×10 dp	9	28.5
MCHH-40	44	34	$\phi 42^{+0.05}_0 \times 2$ dp	M6×1.0×12 dp	11	28.5



*Connect with*

## ***ELECTRIC ACTUATOR***

Connect gripper with electric actuator to achieve workpiece displacement.



### Features

- Compact design to ensure minimum interference while operating; robust T rail design, ensure accurate gripping.
- Can reach maximum torque suitable for long jaws design.
- Oval piston-driven design ensure maximum gripping force.
- Hose-free direct connection: Air supply channel can connect directly without piping or through tread to assure the flexibility of supplying compressed air on any kind of automation system.
- Magnetic as standard.

### Specification

Model	MCHS							
Acting type	Double acting							
Body specification	50	66	80	100	125	160	200	300
Stroke per-jaw(mm)	4	6	8	10	12	16	20	30
Effective external gripping force (N) (*1)	77	135	285	359	600	884	1606	3411
Close/Open time(s)	0.02	0.03	0.04	0.07	0.1	0.1	0.35	0.4
Medium	Air							
Operating pressure range	0.3~0.8 MPa							
Compressed air consumption(cm³)	4.1	10.1	23.6	39.3	85	85	330	1000
Ambient temperature	+5°C~ +80°C							
Lubrication	Not required							
Sensor switch (*2)	2 wire	RDVE(V): Non-contact						
	3 wire	RNFE(V): NPN, RPE(V): PNP						
Proximity sensor	-	RDP8 (Please refer to page 92)						
Accessories	Mounting block, Accessory kits							
Weight (kg)	0.14	0.27	0.495	0.85	1.6	3.0	5.7	14.2

### Order example

MCHS — 50 — SD

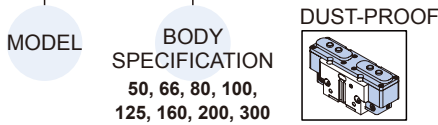

### Dust-proof

SD — MCHS — 50

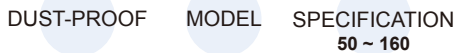

### Installation of sensor switch & speed controller

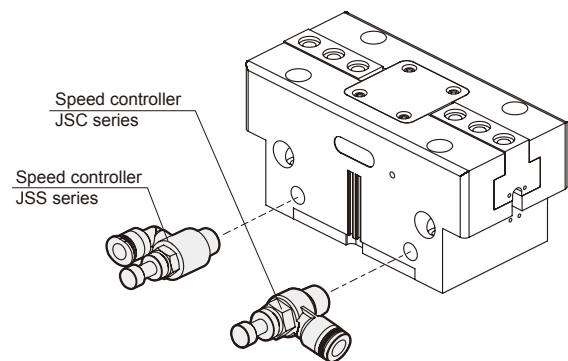
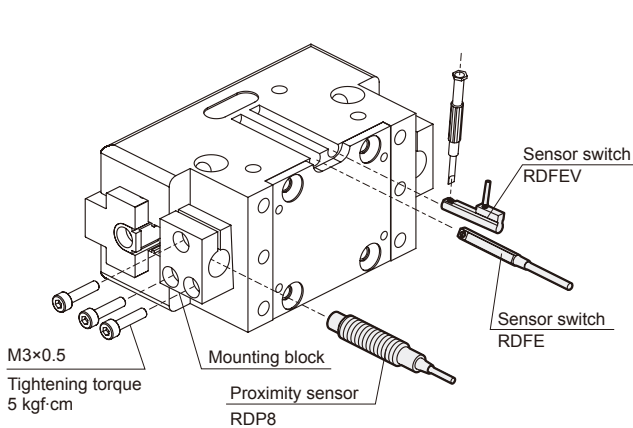

\*1. Under the condition of clamping length 40mm and operation pressure 0.6 MPa.

\*2. R\*FE(V) specification, please refer to page 90.

\* Each gripper needs at least two speed control valves to control speed.  
\* Speed controller specification, please refer to Mindman website.

## PARALLEL GRIPPER (2-Finger)

mindman

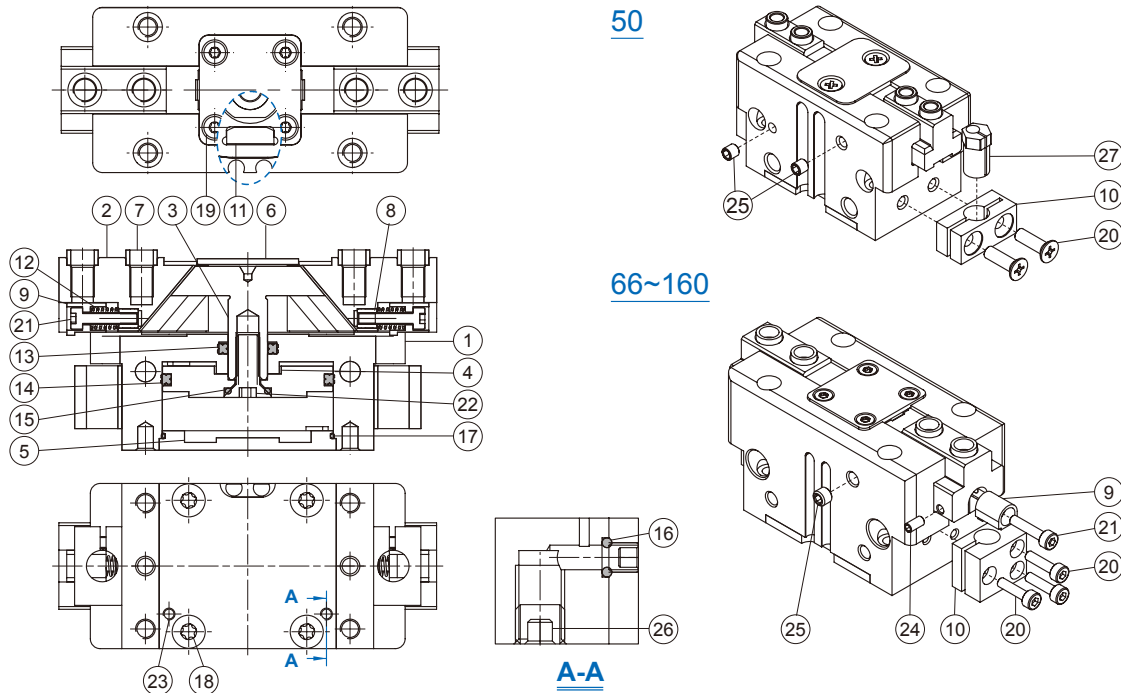

### Material

No.	Part name	Material	Body spec & Q'y						Repair kits (inclusion)
			50	66	80	100	125	160	
1	Body	Aluminum alloy	1						
2	Finger	Mid carbon steel	2						
3	Rod	Mid carbon steel	1						
4	Piston	Aluminum alloy	1						
5	End cover	Aluminum alloy	1						
6	Plate cover	Stainless steel	1						
7	Centering sleeve	Stainless steel	4						
8	Thread insert	Brass	-			2			
9	Sensor adj block	Aluminum alloy	-		2				
10	Sensor holder	PBT+30%GF	2						
11	Magnet	Magnet material	1						
12	Spring	SWP	-		2				
13	Rod packing	NBR	1						●
14	Piston packing	NBR	1						●
15	O-ring	NBR	1						●
16	O-ring	NBR	3	4	2			●	
17	O-ring	NBR	1						●
18	Screw	Carbon steel	4						
19	Screw	Carbon steel	2	4					
20	Bolt	Stainless steel	4	6					
21	Hex bolt	Stainless steel	-			2			
22	Hex bolt	Stainless steel	1						
23	Hex screw	Stainless steel	2						
24	Hex screw	Carbon steel	4						
25	Hex screw	Stainless steel	2						
26	Hex screw	Stainless steel	2						
27	Adjust socket	Stainless steel	2	-					

### Order example of repair kits

Model	Repair kits
MCHS-50	<b>PS-MCHS-50</b>
MCHS-66	<b>PS-MCHS-66</b>
MCHS-80	<b>PS-MCHS-80</b>
MCHS-100	<b>PS-MCHS-100</b>
MCHS-125	<b>PS-MCHS-125</b>
MCHS-160	<b>PS-MCHS-160</b>

### Order example of accessory kits

Model	Accessory kits
MCHS-50	<b>AK-MCHS-50</b>
MCHS-66	<b>AK-MCHS-66</b>
MCHS-80	<b>AK-MCHS-80</b>
MCHS-100	<b>AK-MCHS-100</b>
MCHS-125	<b>AK-MCHS-125</b>
MCHS-160	<b>AK-MCHS-160</b>

O-ring (x2)	Iron plug (x2)
PIN (x2)	Centering sleeve (x4)

PARALLEL GRIPPER

ANGULAR GRIPPER

SENSOR SWITCH

CAUTION

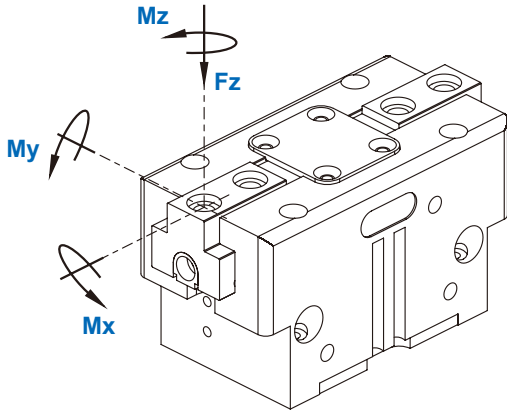

Code Model	Mx max. (Nm)	My max. (Nm)	Mz max. (Nm)	Fz max. (N)
<b>MCHS-50</b>	15	15	8	700
<b>MCHS-66</b>	50	45	35	1200
<b>MCHS-80</b>	80	60	50	1800
<b>MCHS-100</b>	100	90	75	2500
<b>MCHS-125</b>	120	120	100	3200
<b>MCHS-160</b>	160	180	140	5000
<b>MCHS-200</b>	180	220	170	7000
<b>MCHS-300</b>	275	300	200	9000

### Holding force

**MCHS-50**

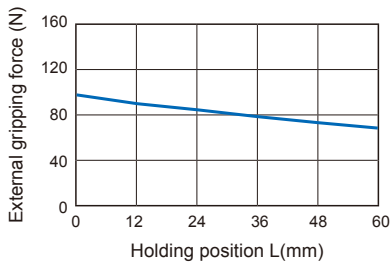

**MCHS-66**

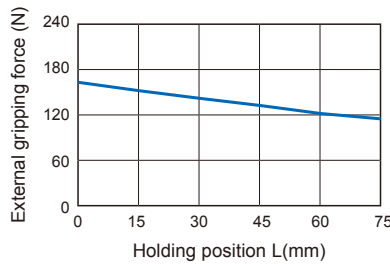

**MCHS-80**

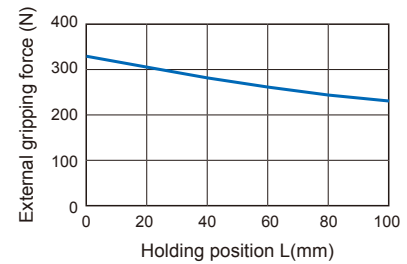

**MCHS-100**

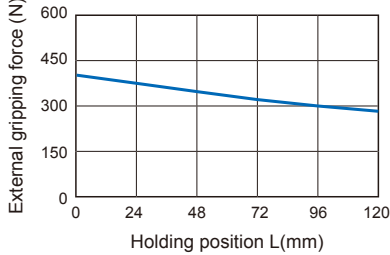

**MCHS-125**

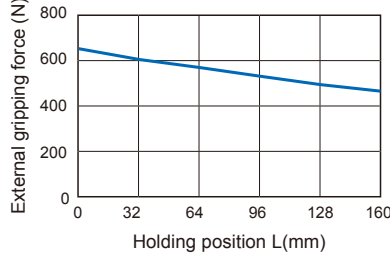

**MCHS-160**

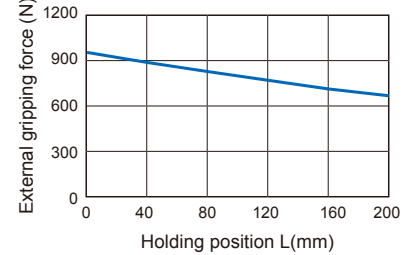

**MCHS-200**

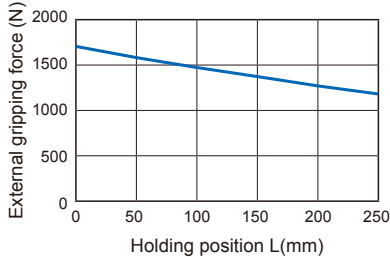

**MCHS-300**

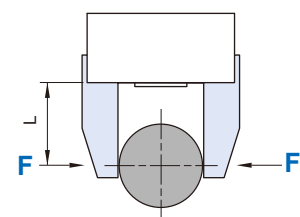
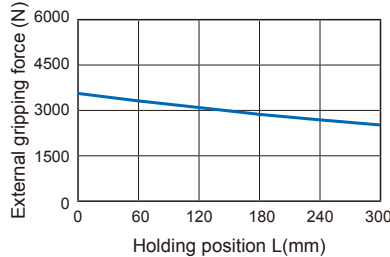

\* Operating pressure 0.6 MPa.

### Max. feasible centrifugal degree

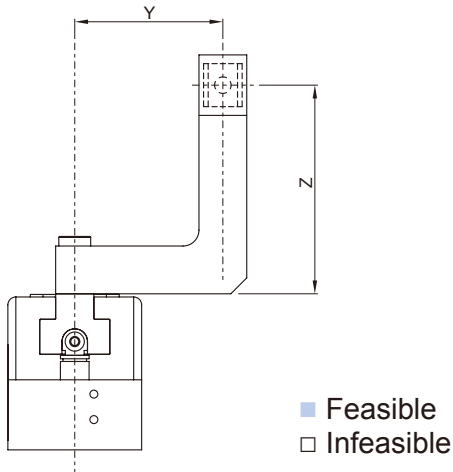

**MCHS-50**

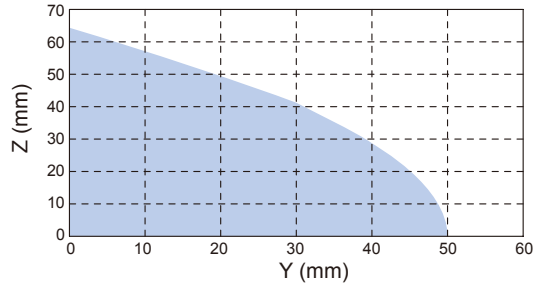

**MCHS-66**

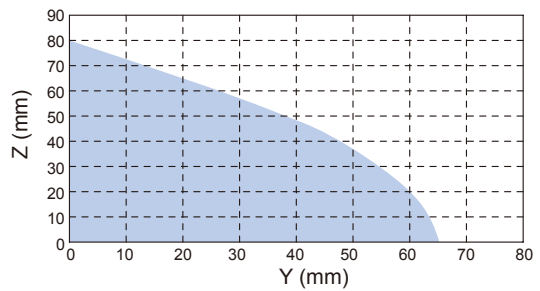

**MCHS-80**

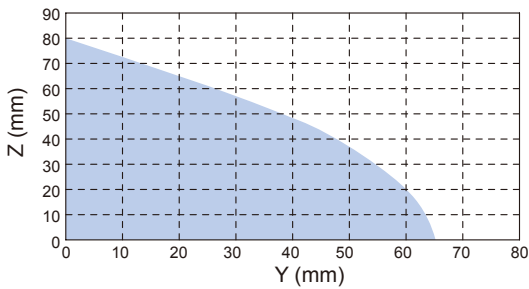

**MCHS-100**

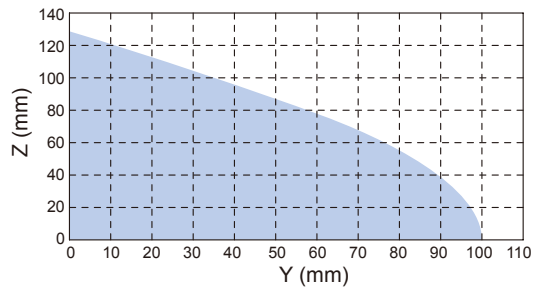

**MCHS-125**

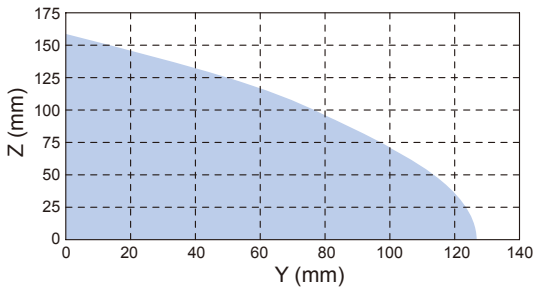

**MCHS-160**

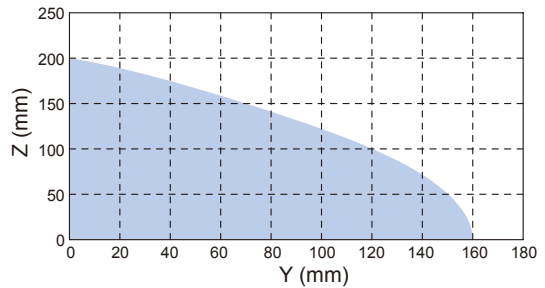

**MCHS-200**

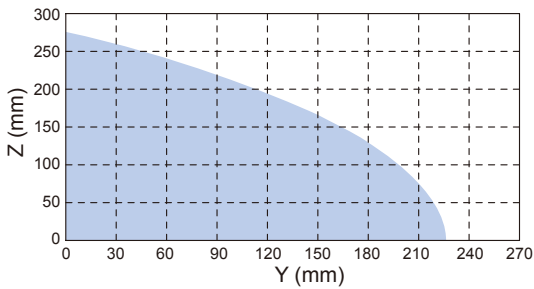

**MCHS-300**

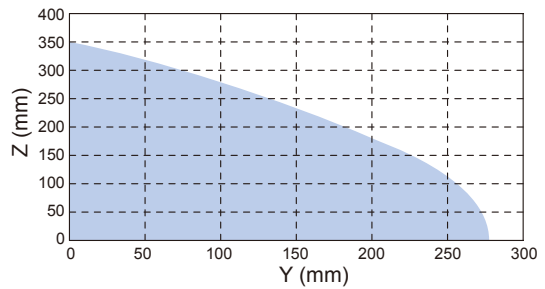

## PARALLEL GRIPPER (2-Finger)

### Internal structure & Movement description

Compressed air will push or press the oval piston.  
By tilting the working surface, the wedge hook will transfer the movement to side movement, and initiate the action of the two base jaws simultaneously.

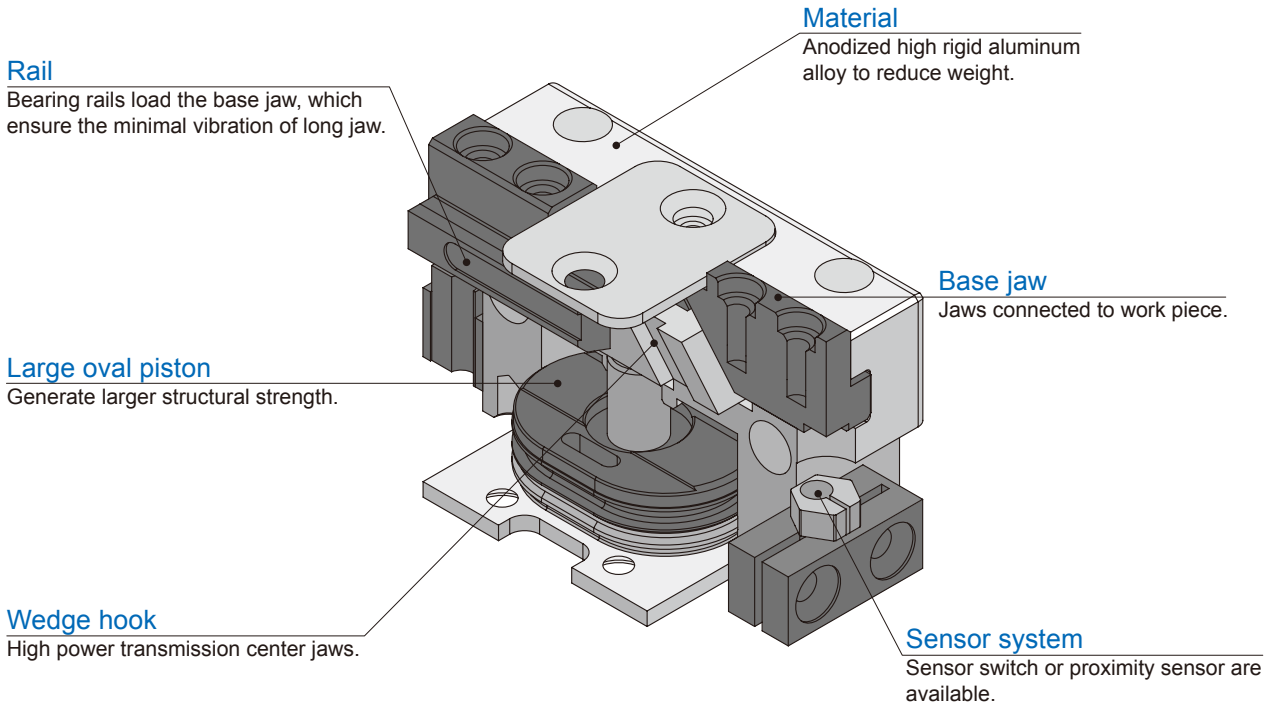

### Application examples

Connect gripper with robot to achieve burr removal.



### Hose-free direct connection

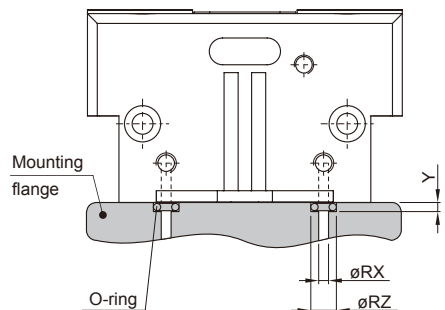

Code Model	R	RX	RZ	Y
MCHS-50	M2	2	4	0.7
MCHS-66	M3	3	5	0.7
MCHS-80	M3	3	5	0.7
MCHS-100	M5	5	8	1.1
MCHS-125	M5	5	8	1.1
MCHS-160	M5	5	8	1.1
MCHS-200	M5	5	8	1.1
MCHS-300	M5	5	8	1.1

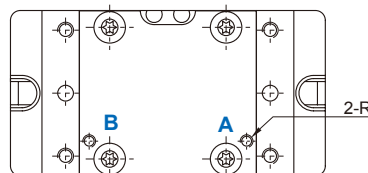

**A** : Gripper open  
**B** : Gripper close

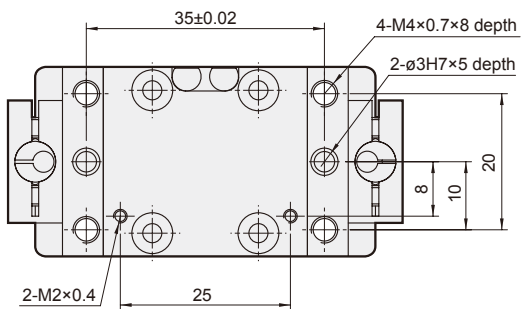
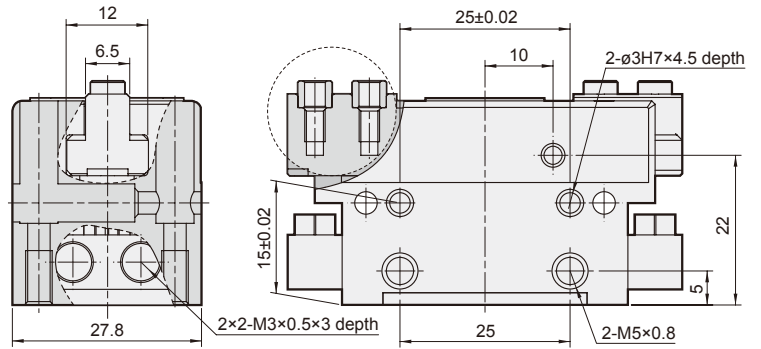
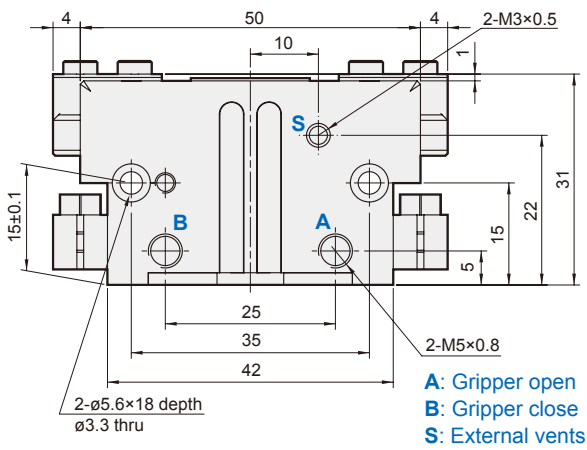
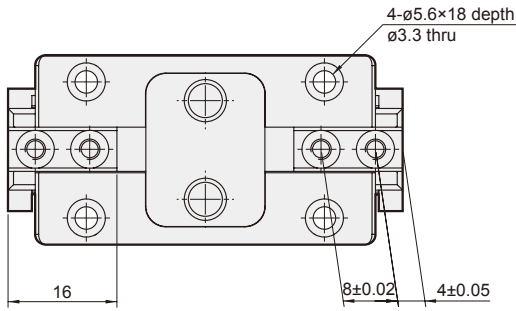

### Centering sleeve

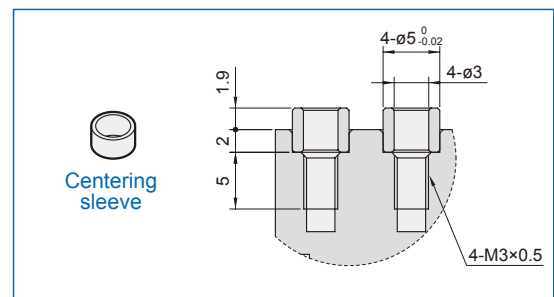

PARALLEL GRIPPER (2-Finger)

66~100

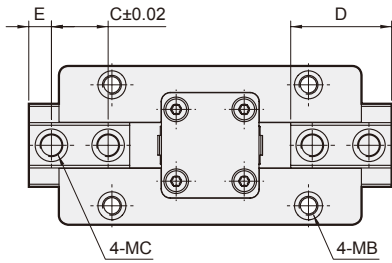

125~160

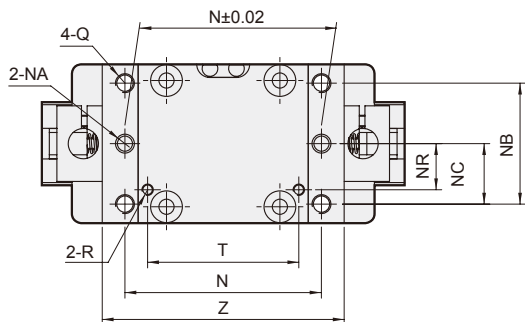
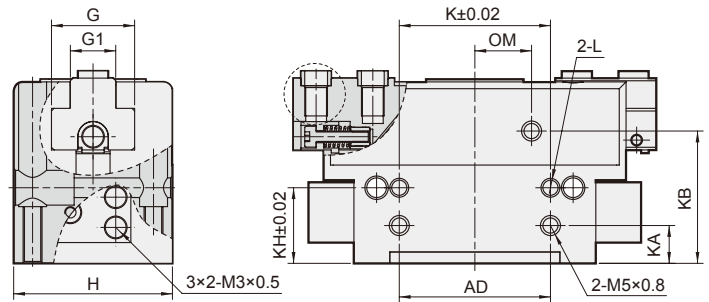
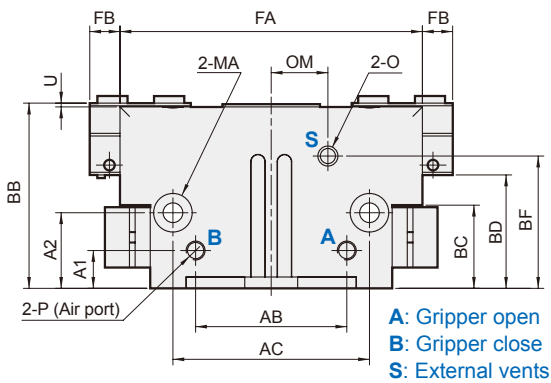
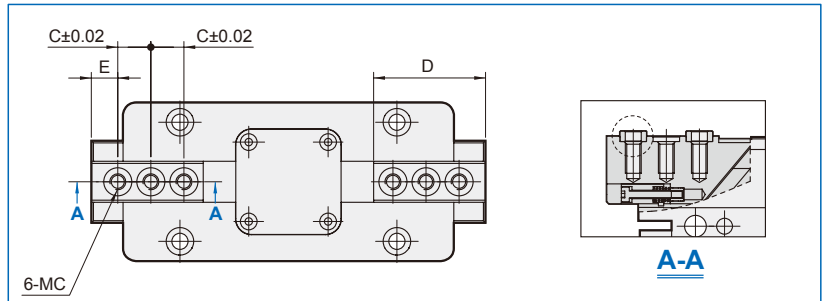

Centering sleeve

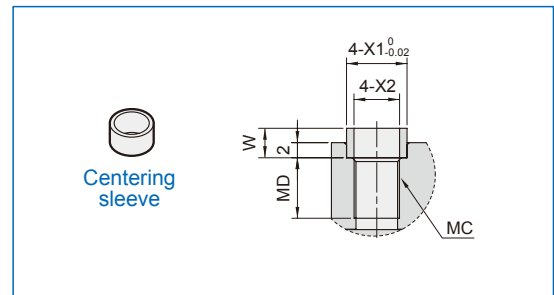

Code Spec.	A1	A2	AB	AC	AD	BB	BC	BD	BF	C	D	E	FA	FB	G	G1	H	K	KA	KB	KH	L	MA
66	5	18	28	42	28	39	18.5	23	27.5	12	22	5	64	6	17	10	36	20	5	27.5	18	ø4H7×4dp	ø7.4×13dp, ø4.2 thru
80	10	20	40	52	40	49	22	30	35	15	26.7	6	80	8	22	12	42	40	10	35	20	ø4H7×6dp	ø9.2×16dp, ø5.2 thru
100	12	25	48	66	54	55	28	33	38	18	34.2	10	100	10	26	14	50	50	12	38	25	ø5H7×7dp	ø10.4×28dp, ø6.2 thru
125	13	30	62	82	65	64	32	38.5	45	12.5	42.3	10	125	12	31	15.5	60	60	13	45	30	ø6H7×8dp	ø13.5×34dp, ø8.4 thru
160	15.5	28	78	100	82	78	39	46	53	18	54.8	10	160	16	39	20	72	76	15.5	53	28	ø6H7×10dp	ø13.5×47dp, ø8.4 thru

Code Spec.	MB	MC	MD	N	NA	NB	NC	NR	O	OM	P	Q	R	T	U	W	X1	X2	Z
66	ø7.4×24dp, ø4.2 thru	M4×0.7	6	42	ø4H7×6dp	27	13.5	11	M5×0.8	12	M5×0.8	M5×0.8×10dp	M3×0.5	28	1	3.9	ø6	ø4	52
80	ø7.4×33dp, ø4.3 thru	M6×1.0	8	52	ø4H7×6dp	32	16	12.2	M5×0.8	15	M5×0.8	M5×0.8×10dp	M3×0.5	40	1	3.9	ø8	ø6	64
100	ø9×21.5dp, ø5.1 thru	M6×1.0	10	66	ø5H7×8dp	38	19	16	M5×0.8	16	G1/8	M6×1.0×10dp	M5×0.8	48	1	3.9	ø10	ø6	80
125	ø10.4×40dp, ø6.8 thru	M6×1.0	12	82	ø6H7×8dp	45	22.5	18	M5×0.8	20	G1/8	M8×1.25×10dp	M5×0.8	60	1	3.9	ø10	ø6	100
160	ø10.4×37dp, ø6.8 thru	M8×1.25	12	100	ø6H7×8dp	56	28	22	M5×0.8	27	G1/8	M8×1.25×10dp	M5×0.8	76	1	3.9	ø12	ø8	125

## PARALLEL GRIPPER (2-Finger)

mindman

PARALLEL GRIPPER

ANGULAR GRIPPER

SENSOR SWITCH

CAUTION

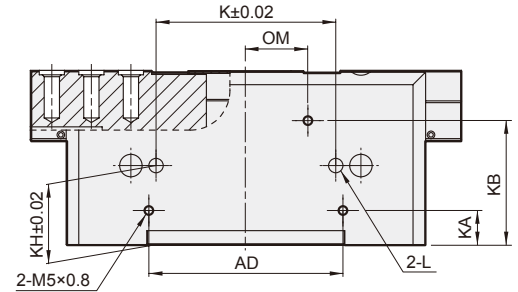
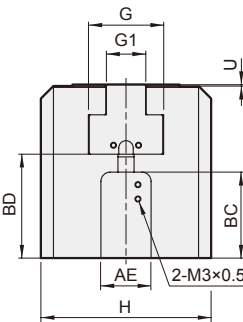
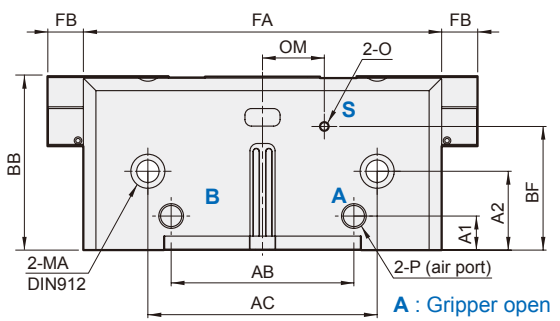
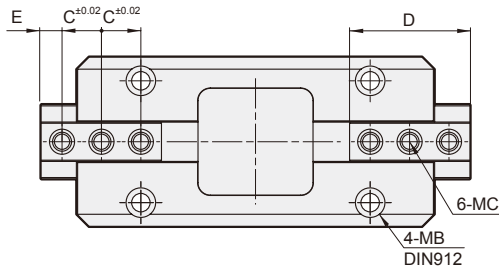

### Centering sleeve

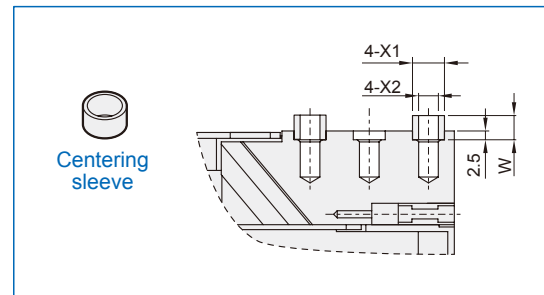
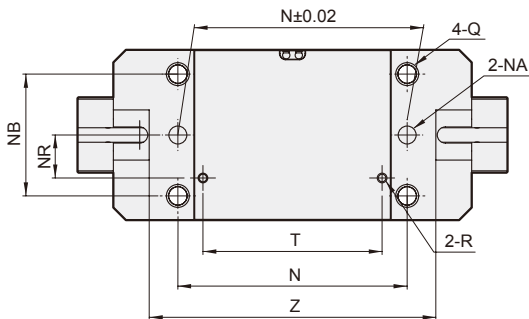

Code Spec.	A1	A2	AB	AC	AD	AE	BB	BC	BD	BF	C	D	E	FA	FB	G	G1	H	K	KA	KB	KH	L
200	19	44	102	128	108	28	97	48	58	69	22	67.5	12	200	20	42	22	95	100	19	69	44	ø8H7×8 dp
300	19	66	150	180	152	30	130	67	78	92	30	91.0	15	260	30	66	32	139	140	19	92	66	ø10H7×12 dp

Code Spec.	MA	MB	MC	MD	N	NA	NB	NR	O	OM	P
200	ø19×55 dp, ø12.5 thru	ø16.5×62 dp, ø10.2 thru	M10×1.5×20 dp	20	128	ø10H7×10 dp	68	24	M5×0.8	34.5	G1/4
300	ø18.5×100 dp, ø12.4 thru	ø16.5×72 dp, ø10.2 thru	M12×1.75×20 dp	20	180	ø10H7×12 dp	100	24	M5×0.8	43	G1/4

Code Spec.	Q	R	T	U	W	X1	X2	Z
200	M12×1.75×17 dp	M5×0.8	100	0.8	4.9	ø14h7	ø11	160
300	M12×1.75×16 dp	M5×0.8	150	0.8	4.9	ø18h7	ø12.5	220

## PARALLEL GRIPPER (2-Finger)

- For dusty environment usage.
- When installing soft-jaws, the length of jaws are measured from the the body surface.
- Heat resistance type of modules are also available. Please contact our sales department.

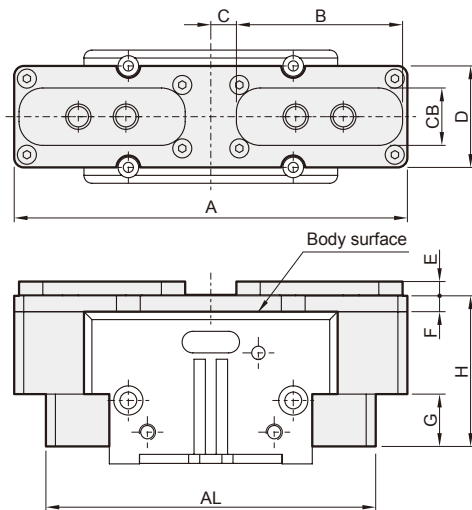

Code Spec.	A	AL	B	C	CB	D	E	F	G	H
50	81.2	58.6	30	6	13	24	4.5	5	12	32
66	104	92	41	6.5	16.2	30	4.5	5	16.5	41
80	124	104	52.4	8.3	18.1	32	4.5	5	16.5	47.5
100	144	124	61	10.5	22	38	4.5	5	16.5	49
125	177	157	72	16	22	45	4.5	5	23	59
160	231	182	93	21.5	25	56	4.5	6	18	62



*Connect with*

## ***ELECTRIC ACTUATOR***

Connect gripper with electric actuator to achieve workpiece displacement.

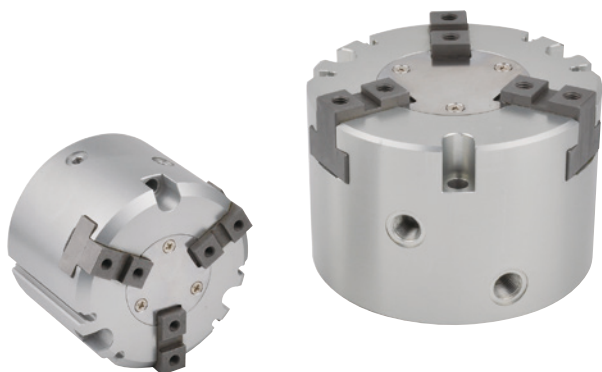

### Features

- Through holes in body enable simple mounting.
- Body manufactured from high tensile, anodised aluminum giving good resistance to corrosion.
- Available with sensors.
- Magnetic as standard.

### Order example

MCHG2 – 16 M – □

MODEL

TUBE I.D.  
16, 20, 25, 32, 40,  
50, 63, 80, 100, 125

M: Magnet  
\* Magnetic as  
standard.

PORT THREAD  
Blank: M thread  
(only for  $\phi 16\sim\phi 63$ )  
Blank: Rc thread  
G: G thread  
NPT: NPT thread  
(only for  $\phi 80\sim\phi 125$ )

### Specification

Model	MCHG2										
Acting type	Double acting										
Tube I.D. (mm)	16	20	25	32	40	50	63	80	100	125	
Stroke (mm)	4	4	6	8	8	12	16	20	24	32	
Port size	M3×0.5	M5×0.8					Rc1/8	Rc1/4	Rc3/8		
Medium	Air										
Operating pressure (MPa)	0.2~0.6				0.1~0.6						
Ambient temperature	-10~+60°C (No freezing)										
Repeatability	±0.01 mm										
Max. operating frequency (c.p.m)	120			60				30			
Lubrication	Not required										
Effective gripping force N (lbf) at (0.5 MPa) (*)	External	14(3.1)	25(5.6)	42(9.4)	74(16.6)	118(26.5)	187(42)	335(75)	500(112)	750(169)	1270(285)
	Internal	16(3.6)	28(6.3)	47(10.6)	82(18.4)	130(29)	204(46)	359(81)	525(118)	780(175)	1320(297)
Sensor switch	2 wire	RDFE(V): Non-contact (Please refer to page 90)									
	3 wire	RNFE(V): NPN, RPFE(V): PNP									
Weight (g)	80	110	150	240	400	540	1020	1880	3300	6200	

\* Values for  $\phi 16\sim\phi 25$  are with gripping length(L) = 20 mm, for  $\phi 32\sim\phi 63$  with gripping length(L) = 30 mm, and for  $\phi 80\sim\phi 125$  with gripping length(L) = 50 mm. Refer to "Effective Gripping Force" data for the gripping force at each gripping position.

### Installation

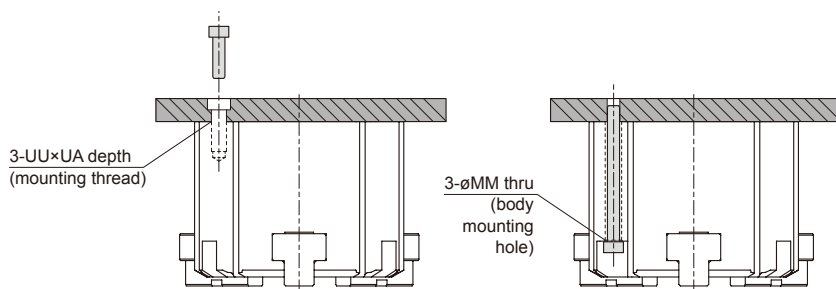

Model	MM	UU×UA	Bolt
MCHG2-16	3.4	M3×0.5×4.5	M3×0.5
MCHG2-20	3.4	M3×0.5×6	M3×0.5
MCHG2-25	4.5	M4×0.7×6	M4×0.7
MCHG2-32	4.5	M4×0.7×6	M4×0.7
MCHG2-40	5.5	M5×0.8×7.5	M5×0.8
MCHG2-50	5.5	M5×0.8×10	M5×0.8
MCHG2-63	6.6	M6×1.0×9	M6×1.0
MCHG2-80	6.6	M6×1.0×12	M6×1.0
MCHG2-100	9	M8×1.25×16	M8×1.25
MCHG2-125	11	M10×1.5×20	M10×1.5

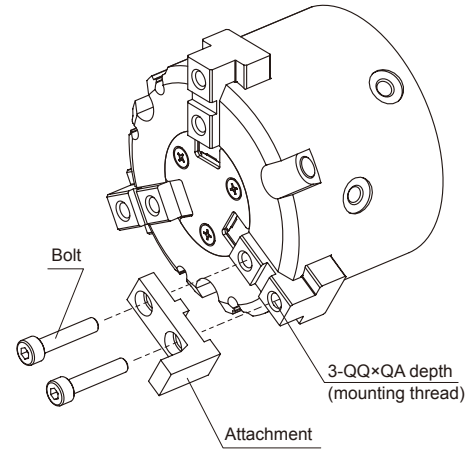
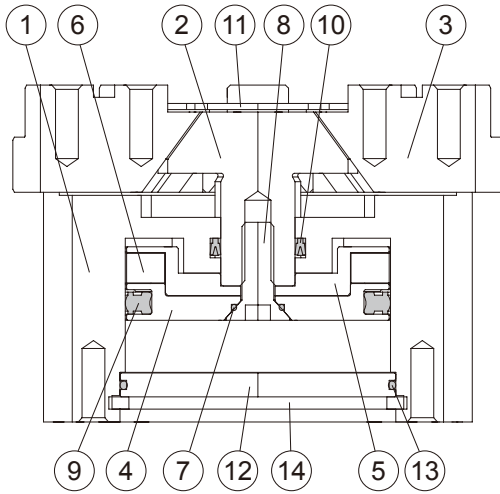

### Material

No.	Part name	Material	Repair kits (inclusion)
1	Body	Aluminum alloy	
2	Lever	Carbon steel	
3	Slider	Carbon steel	
4	Piston	Aluminum alloy	
5	Piston-R	Aluminum alloy	
6	Magnet ring	Magnet material	
7	O-ring	NBR	●
8	Piston bolt	Carbon steel	
9	Piston packing	NBR	●
10	Rod packing	NBR	●
11	Table	Stainless steel	
12	End plate	Aluminum alloy	
13	O-ring	NBR	●
14	Snap ring	Carbon steel	

### Mounting precautions

The tightening torque of slider mounting bolt, please refer to the table below.

Model	QQ×QA	Bolt	Max. tightening torque (N.m)
<b>MCHG2-16</b>	M3×0.5×5	M3×0.5	0.59
<b>MCHG2-20</b>	M3×0.5×6	M3×0.5	0.59
<b>MCHG2-25</b>	M3×0.5×6	M3×0.5	0.59
<b>MCHG2-32</b>	M4×0.7×8	M4×0.7	1.4
<b>MCHG2-40</b>	M4×0.7×8	M4×0.7	1.4
<b>MCHG2-50</b>	M5×0.8×8	M5×0.8	2.8
<b>MCHG2-63</b>	M5×0.8×8	M5×0.8	2.8
<b>MCHG2-80</b>	M6×1.0×12	M6×1.0	4.8
<b>MCHG2-100</b>	M8×1.25×16	M8×1.25	12
<b>MCHG2-125</b>	M10×1.5×20	M10×1.5	24

### Order example of repair kits

Tube I.D.	Repair kits	Tube I.D.	Repair kits
ø16	<b>PS-MCHG2-16</b>	ø63	<b>PS-MCHG2-63</b>
ø20	<b>PS-MCHG2-20</b>	ø80	<b>PS-MCHG2-80</b>
ø25	<b>PS-MCHG2-25</b>	ø100	<b>PS-MCHG2-100</b>
ø32	<b>PS-MCHG2-32</b>	ø125	<b>PS-MCHG2-125</b>
ø40	<b>PS-MCHG2-40</b>		
ø50	<b>PS-MCHG2-50</b>		

### Effective gripping force

\* Finger selection please refer to page 6.

Indication of effective gripping force.

The effective gripping force shown in the graphs to the right is expressed as  $F$ , which is the thrust of one finger, when three fingers and attachments are in full contact with the workpiece as shown in the figure below.

1N=0.102 kgf  
1MPa=10.2 kgf/cm<sup>2</sup>

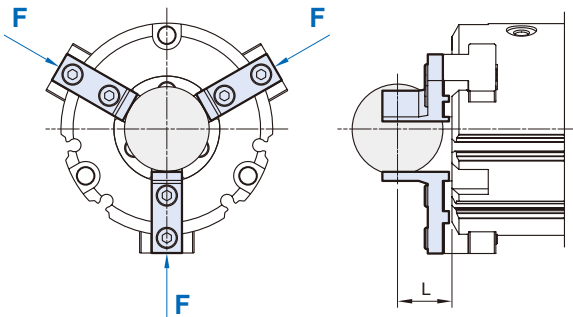

### External grip

### External gripping force

MCHG2-16

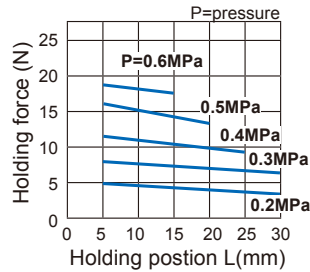

MCHG2-50

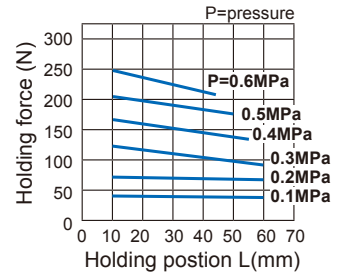

MCHG2-20

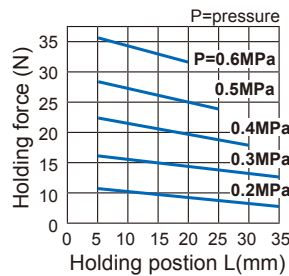

MCHG2-63

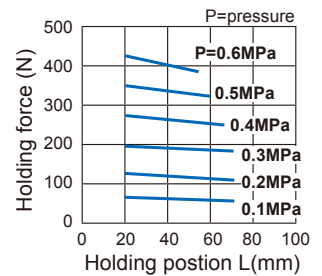

MCHG2-25

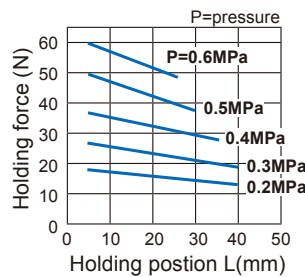

MCHG2-80

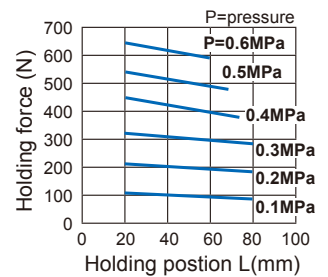

MCHG2-32

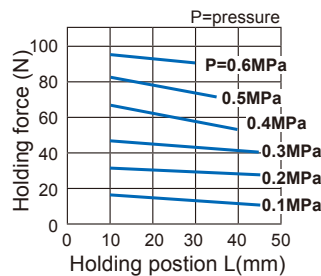

MCHG2-100

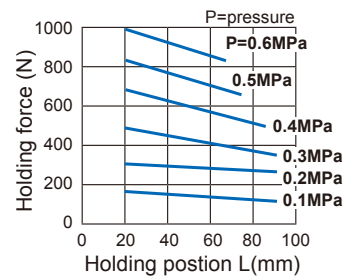

MCHG2-40

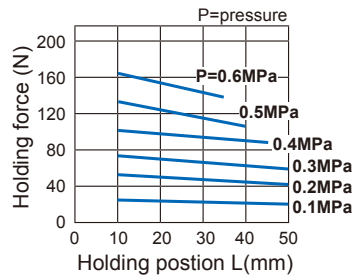

MCHG2-125

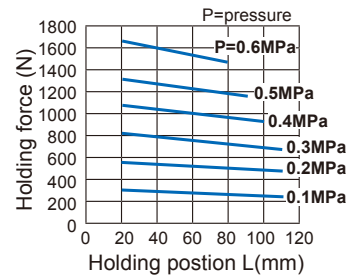

### Effective gripping force

\* Finger selection please refer to page 6.

Indication of effective gripping force.

The effective gripping force shown in the graphs to the right is expressed as F, which is the thrust of one finger, when three fingers and attachments are in full contact with the workpiece as shown in the figure below.

1N=0.102 kgf  
1MPa=10.2 kgf/cm<sup>2</sup>

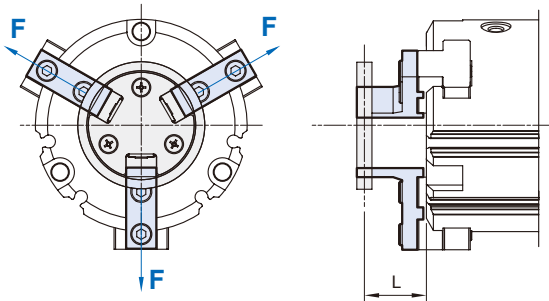

### Internal grip

### Internal gripping force

MCHG2-16

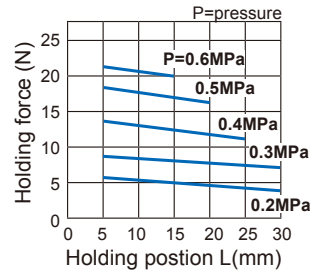

MCHG2-50

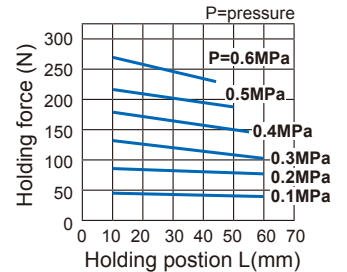

MCHG2-20

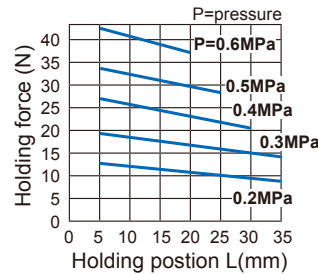

MCHG2-63

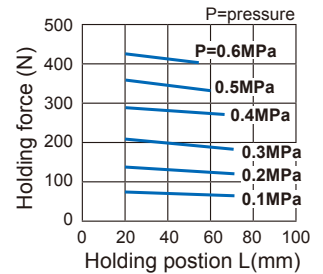

MCHG2-25

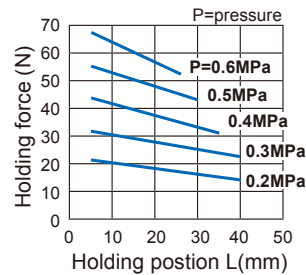

MCHG2-80

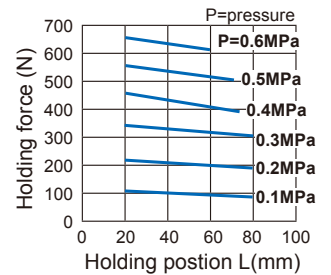

MCHG2-32

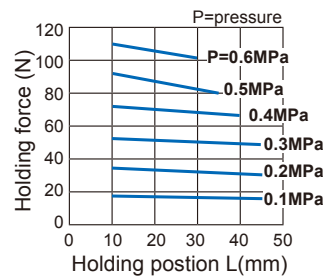

MCHG2-100

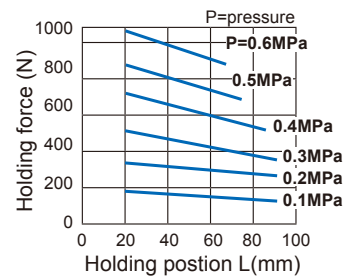

MCHG2-40

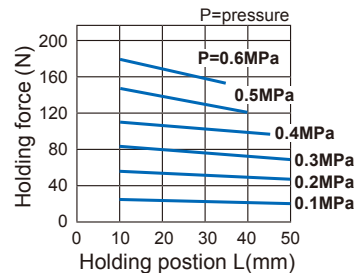

MCHG2-125

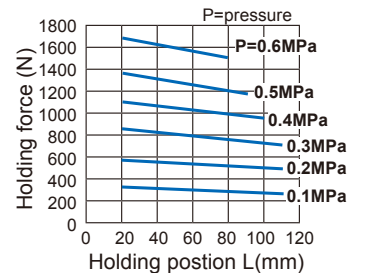

## PARALLEL GRIPPER (3-Finger)

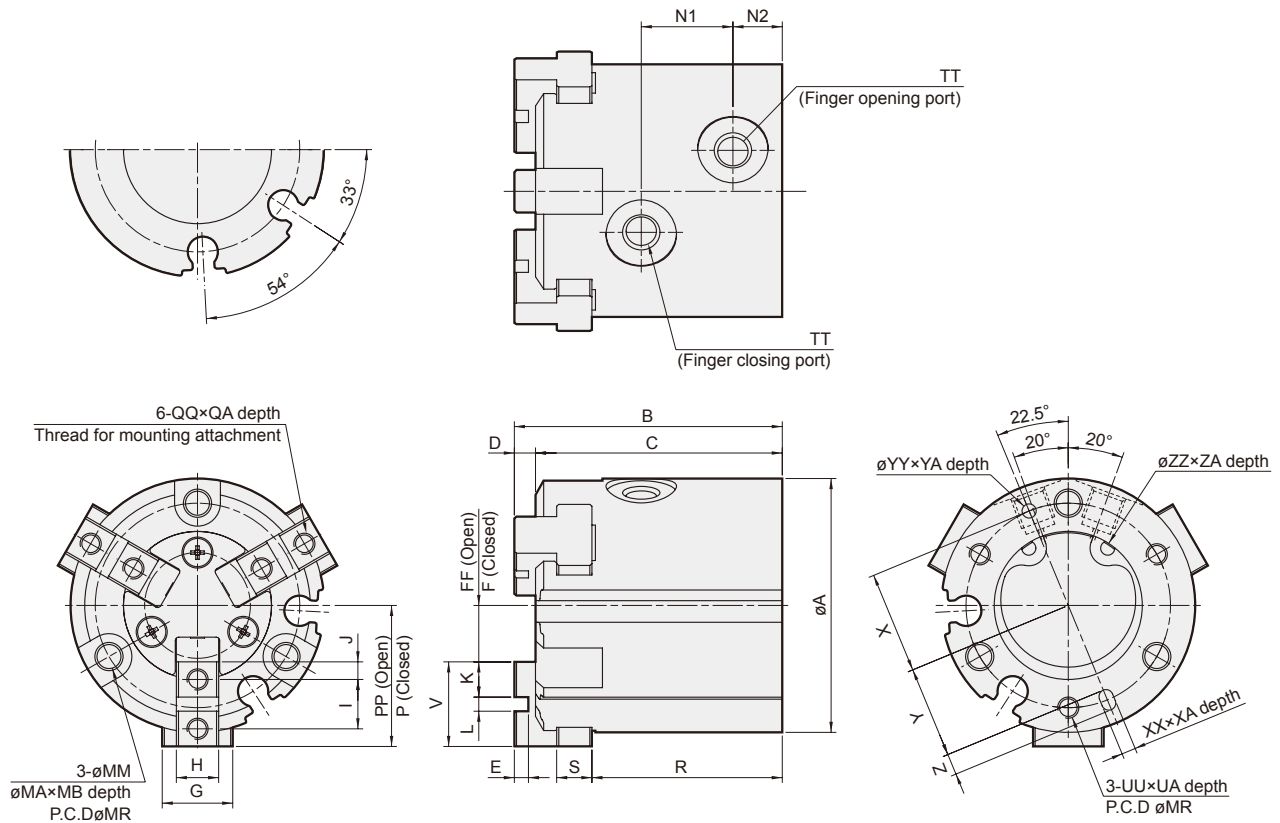

Code Tube I.D.	A	B	C	D	E	F	FF	G	H	I	J	K	L	MA	MB	MM	MR	N1	N2	P	PP	QA	QQ	R	S	TT
16	30	35	32	3	2	5	7	8	5h9 <sup>+0</sup> <sub>-0.030</sub>	6	2	4	2H9 <sup>+0.025</sup> <sub>0</sub>	6.5	8	3.4	25	11	7	15	17	5	M3×0.5	25	4	M3×0.5
20	36	38	35	3	2	6	8	10	6h9 <sup>+0</sup> <sub>-0.030</sub>	7	2.5	5	2H9 <sup>+0.025</sup> <sub>0</sub>	6.5	9.5	3.4	29	13	7	18	20	6	M3×0.5	27	5	M5×0.8
25	42	40	37	3	2	7	10	12	6h9 <sup>+0</sup> <sub>-0.030</sub>	8	3	6	2H9 <sup>+0.025</sup> <sub>0</sub>	8	10	4.5	34	15	7	21	24	6	M3×0.5	28	5	M5×0.8

Code Tube I.D.	UA	UU	V	X	XA	XX	Y	YA	YY	Z	ZA	ZZ
16	4.5	M3×0.5	10	12.5	2	2H9 <sup>+0.025</sup> <sub>0</sub>	11	2	2H9 <sup>+0.025</sup> <sub>0</sub>	3	1.5	17H9 <sup>+0.043</sup> <sub>0</sub>
20	6	M3×0.5	12	14.5	2	2H9 <sup>+0.025</sup> <sub>0</sub>	13	2	2H9 <sup>+0.025</sup> <sub>0</sub>	3	1.5	21H9 <sup>+0.052</sup> <sub>0</sub>
25	6	M4×0.7	14	17	3	3H9 <sup>+0.025</sup> <sub>0</sub>	14.5	3	3H9 <sup>+0.025</sup> <sub>0</sub>	5	1.5	26H9 <sup>+0.052</sup> <sub>0</sub>

## PARALLEL GRIPPER (3-Finger)

mindman

PARALLEL GRIPPER

ANGULAR GRIPPER

SENSOR SWITCH

CAUTION

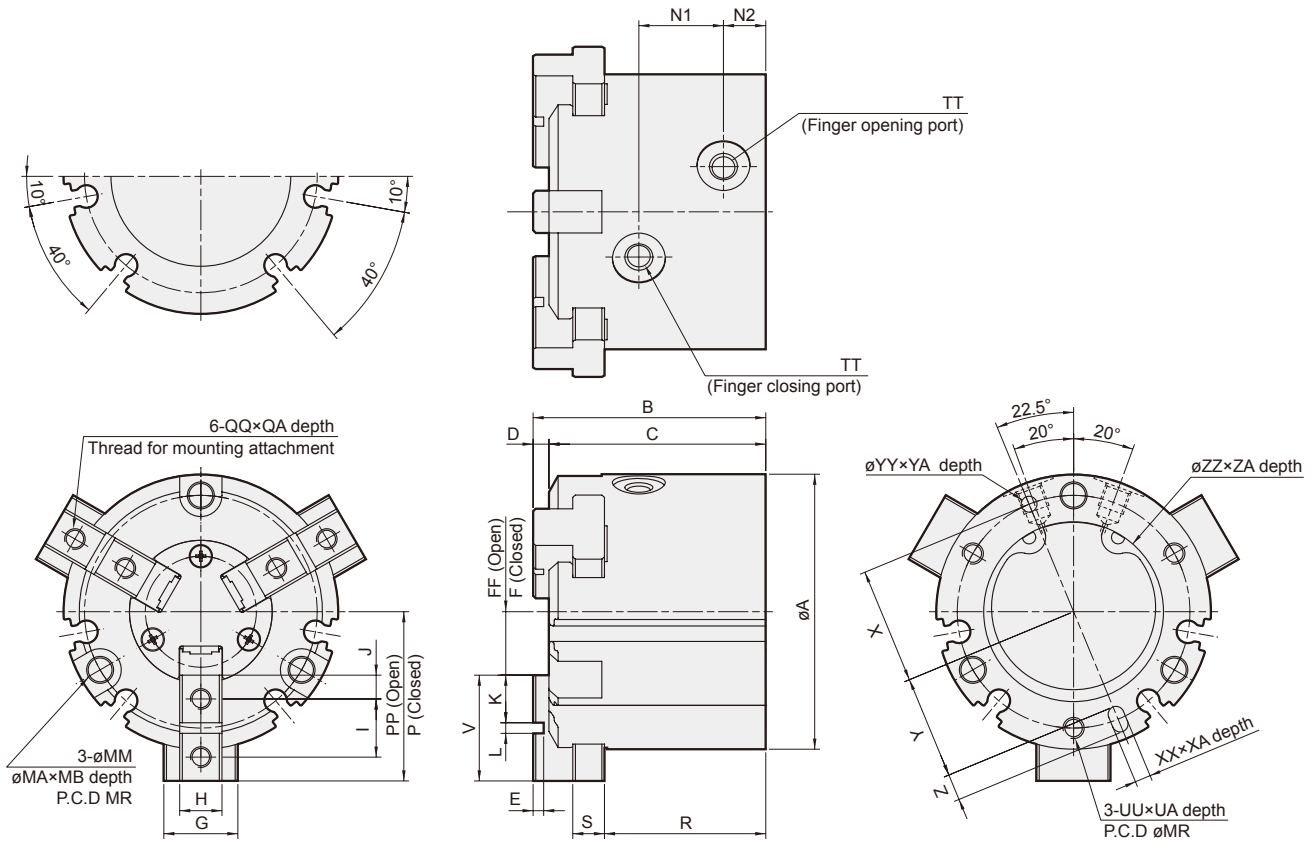

Code Tube I.D.	A	B	C	D	E	F	FF	G	H	I	J	K	L	MA	MB	MM	MR	N1	N2	P	PP	QA	QQ
32	52	44	41	3	2	8	12	14	8h9 <sup>+0</sup> <sub>-0.036</sub>	11	4.5	9	2H9 <sup>+0.025</sup> <sub>-0</sub>	8	9	4.5	44	16	8	28	32	8	M4×0.7
40	62	47	44	3	2	10	14	16	8h9 <sup>+0</sup> <sub>-0.036</sub>	12	4.5	9	3H9 <sup>+0.025</sup> <sub>-0</sub>	9.5	9	5.5	53	17	9	31	35	8	M4×0.7
50	70	55	52	3	2	11	17	18	10h9 <sup>+0</sup> <sub>-0.036</sub>	14	5	10	4H9 <sup>+0.030</sup> <sub>-0</sub>	9.5	12	5.5	62	20	9	35	41	10	M5×0.8
63	86	66	62	4	3	15	23	24	12h9 <sup>+0</sup> <sub>-0.043</sub>	17	5.5	11	6H9 <sup>+0.030</sup> <sub>-0</sub>	11	14	6.6	76	22	12	43	51	10	M5×0.8
80	106	82	77	5	4	21.5	31.5	28	14h9 <sup>+0</sup> <sub>-0.043</sub>	20	6	12	8H9 <sup>+0.036</sup> <sub>-0</sub>	11	19	6.6	95	27	13.5	53.5	63.5	12	M6×1.0
100	134	96	90	6	4	28	40	34	18h9 <sup>+0</sup> <sub>-0.043</sub>	23	7.5	15	8H9 <sup>+0.036</sup> <sub>-0</sub>	14	21	9	118	30.6	18	66	78	16	M8×1.25
125	166	122	114	8	6	30	46	40	22h9 <sup>+0</sup> <sub>-0.052</sub>	31	10.5	21	10H9 <sup>+0.036</sup> <sub>-0</sub>	17.5	34	11	148	38	23.5	82	98	20	M10×1.5

Code Tube I.D.	R	S	TT	UU	UA	V	X	XA	XX	Y	YY	YA	Z	ZA	ZZ
32	30.5	6	M5×0.8	M4×0.7	6	20	22	3	3H9 <sup>+0.025</sup> <sub>-0</sub>	19.5	3H9 <sup>+0.025</sup> <sub>-0</sub>	3	5	2	34H9 <sup>+0.062</sup> <sub>-0</sub>
40	32	7	M5×0.8	M5×0.8	7.5	21	26.5	4	4H9 <sup>+0.030</sup> <sub>-0</sub>	23.5	4H9 <sup>+0.030</sup> <sub>-0</sub>	4	6	2	42H9 <sup>+0.062</sup> <sub>-0</sub>
50	37.5	9	M5×0.8	M5×0.8	10	24	31	4	4H9 <sup>+0.030</sup> <sub>-0</sub>	28	4H9 <sup>+0.030</sup> <sub>-0</sub>	4	6	2	52H9 <sup>+0.074</sup> <sub>-0</sub>
63	44	11	M5×0.8	M6×1.0	9	28	38	5	5H9 <sup>+0.030</sup> <sub>-0</sub>	34.5	5H9 <sup>+0.030</sup> <sub>-0</sub>	5	7	2.5	65H9 <sup>+0.074</sup> <sub>-0</sub>
80	56	12	Rc1/8	M6×1.0	12	32	47.5	6	6H9 <sup>+0.030</sup> <sub>-0</sub>	43.5	6H9 <sup>+0.030</sup> <sub>-0</sub>	6	8	3	82H9 <sup>+0.087</sup> <sub>-0</sub>
100	63	15	Rc1/4	M8×1.25	16	38	59	6	8H9 <sup>+0.036</sup> <sub>-0</sub>	54	8H9 <sup>+0.036</sup> <sub>-0</sub>	6	10	4	102H9 <sup>+0.087</sup> <sub>-0</sub>
125	84	18	Rc3/8	M10×1.5	20	52	74	8	10H9 <sup>+0.036</sup> <sub>-0</sub>	68	10H9 <sup>+0.036</sup> <sub>-0</sub>	8	12	6	130H9 <sup>+0.100</sup> <sub>-0</sub>



### Features

- Compact design to ensure minimum interference while operating; robust T rail design, ensure accurate gripping.
- Can reach maximum torque suitable for long jaws design.
- Circular piston-driven design ensure maximum clamping force.
- Hose-free direct connection: Air supply channel can connect directly without piping or through tread to assure the flexibility of supplying compressed air on any kind of automation system.
- Magnetic as standard.

### Specification

Model	MCHJ							
Acting type	Double acting							
Body specification	50	66	80	100	125	160	200	300
Stroke per-jaw (mm)	4	6	8	10	12	16	20	30
Effective external gripping force (N) (*1)	113	188	292	483	906	1747	2851	5247
Close/Open time (1/s)	0.025	0.03	0.05	0.1	0.2	0.25	0.35	0.8
Medium	Air							
Operating pressure range	0.2~0.8 MPa							
Compressed air consumption (cm <sup>3</sup> )	9.2	21.5	47	100	195	485	850	2300
Ambient temperature	+5°C~ +80°C							
Lubrication	Not required							
Sensor switch (*3)	2 wire	*2	RDFE(V): Non-contact					
	3 wire	*2	RNFE(V): NPN, RPFE(V): PNP					
Proximity sensor	-		RDP8 (Please refer to page 92)					
Accessories	Mounting block, Accessory kits							
Weight (kg)	0.22	0.5	0.85	1.6	2.8	5.2	10.8	26.5

### Order example

MCHJ — 50 — SD

MODEL

BODY SPECIFICATION  
50, 66, 80, 100,  
125, 160, 200, 300

DUST-PROOF

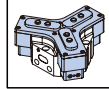

\* The body specification 50~160 with pressure piece is also available, please consult our sales department.

### Dust-proof

SD — MCHJ — 50

DUST-PROOF

MODEL

SPECIFICATION  
50 ~ 160

### Installation of sensor switch & speed controller

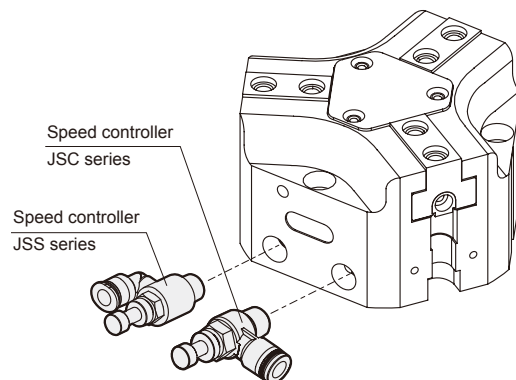
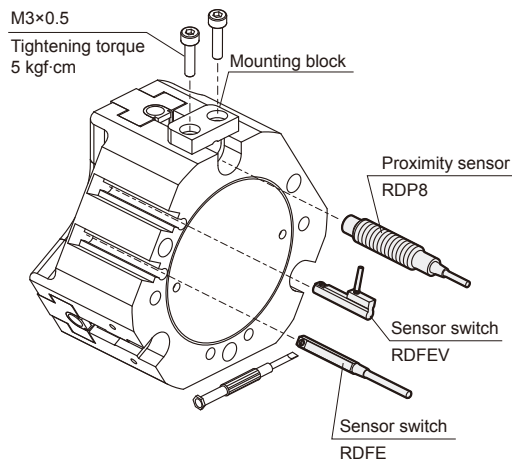

\* Each gripper needs at least two speed control valves to control speed.  
\* Speed controller specification, please refer to Mindman website.

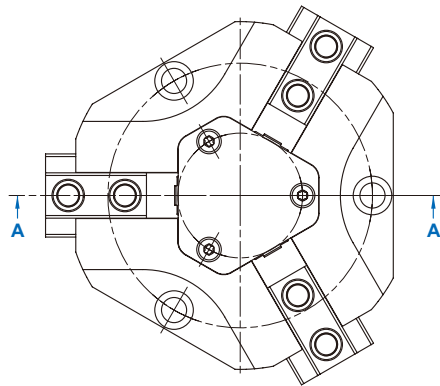

50

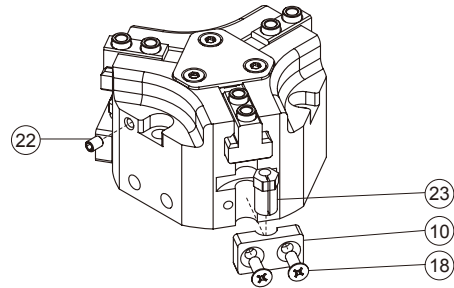

66~160

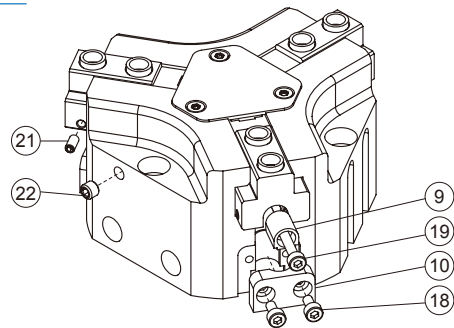
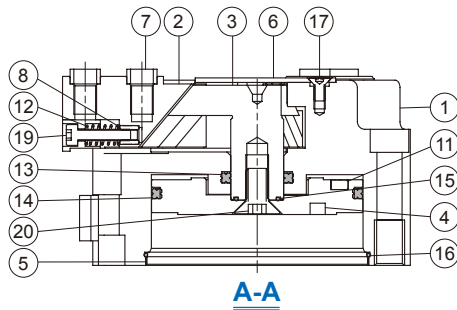

### Material

No.	Body spec Part name	50	66	80	100	125	160	Q'y	Repair kits (inclusion)	
1	Body	Aluminum alloy						1		
2	Finger	Mid carbon steel						3		
3	Rod	Mid carbon steel						1		
4	Piston	Aluminum alloy						1		
5	End cover	Stainless steel						1		
6	Plate cover	Stainless steel						1		
7	Centering sleeve	Stainless steel						6		
8	Thread insert	-	Brass						3	
9	Sensor adj block	-	Aluminum alloy						2	
10	Magnet holder	*1	PBT+30%GF						2	
11	Magnet	Magnet material						1*2		
12	Spring	-	SWP						2	
13	Rod packing	NBR						1	●	
14	Piston packing	NBR						1	●	
15	O-ring	NBR						1	●	
16	O-ring	NBR						1	●	
17	Screw	Carbon steel						3		
18	Bolt	Stainless steel						4		
19	Hex bolt	-	Stainless steel						2	
20	Bolt	Stainless steel						1		
21	Hex screw	-	Stainless steel						4	
22	Hex screw	Stainless steel						3		
23	Adjust socket	SUS	-						2	

\*1. Aluminum alloy \*2. Body spec 125 Q'y: 2 pcs

### Order example of repair kits

Model	Repair kits
MCHJ-50	PS-MCHJ-50
MCHJ-66	PS-MCHJ-66
MCHJ-80	PS-MCHJ-80
MCHJ-100	PS-MCHJ-100
MCHJ-125	PS-MCHJ-125
MCHJ-160	PS-MCHJ-160

### Order example of accessory kits

Model	Accessory kits
MCHJ-50	AK-MCHJ-50
MCHJ-66	AK-MCHJ-66
MCHJ-80	AK-MCHJ-80
MCHJ-100	AK-MCHJ-100
MCHJ-125	AK-MCHJ-125
MCHJ-160	AK-MCHJ-160

O-ring (x2)	Iron plug (x2)
PIN (x2)	Centering sleeve (x6)

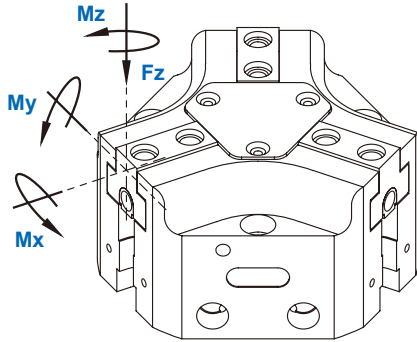

Code Model	Mx max. (Nm)	My max. (Nm)	Mz max. (Nm)	Fz max. (N)
MCHJ-50	15	15	8	700
MCHJ-66	50	45	35	1200
MCHJ-80	80	60	50	1800
MCHJ-100	100	90	75	2500
MCHJ-125	120	120	100	3200
MCHJ-160	160	180	140	5000
MCHJ-200	180	220	170	7000
MCHJ-300	275	300	200	9000

### Holding force

**MCHJ-50**

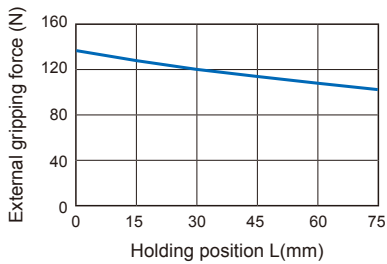

**MCHJ-66**

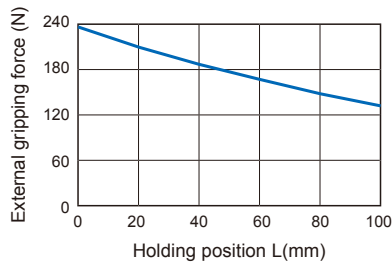

**MCHJ-80**

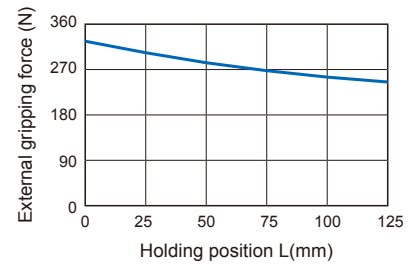

**MCHJ-100**

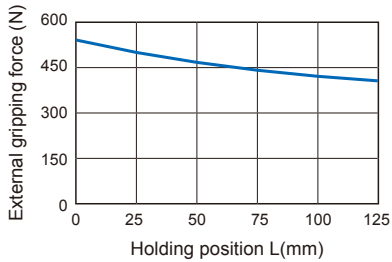

**MCHJ-125**

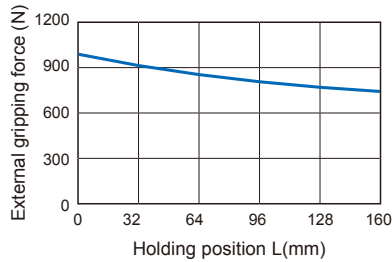

**MCHJ-160**

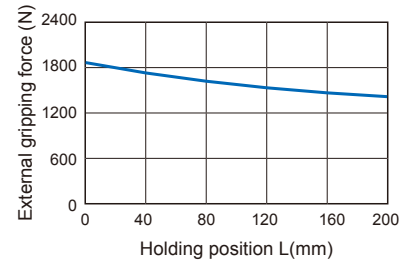

**MCHJ-200**

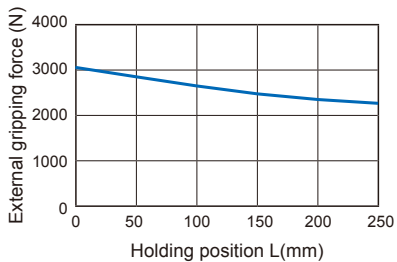

**MCHJ-300**

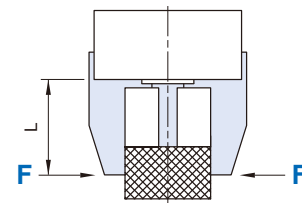
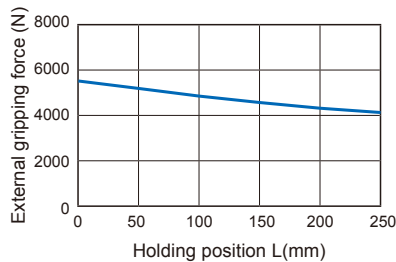

\* Operating pressure 0.6 MPa.

### Internal structure & Movement description

Compressed air will push or press the circular piston.  
By tilting the working surface, the wedge hook will transfer the movement to side movement, and initiate the action of the three base jaws simultaneously.

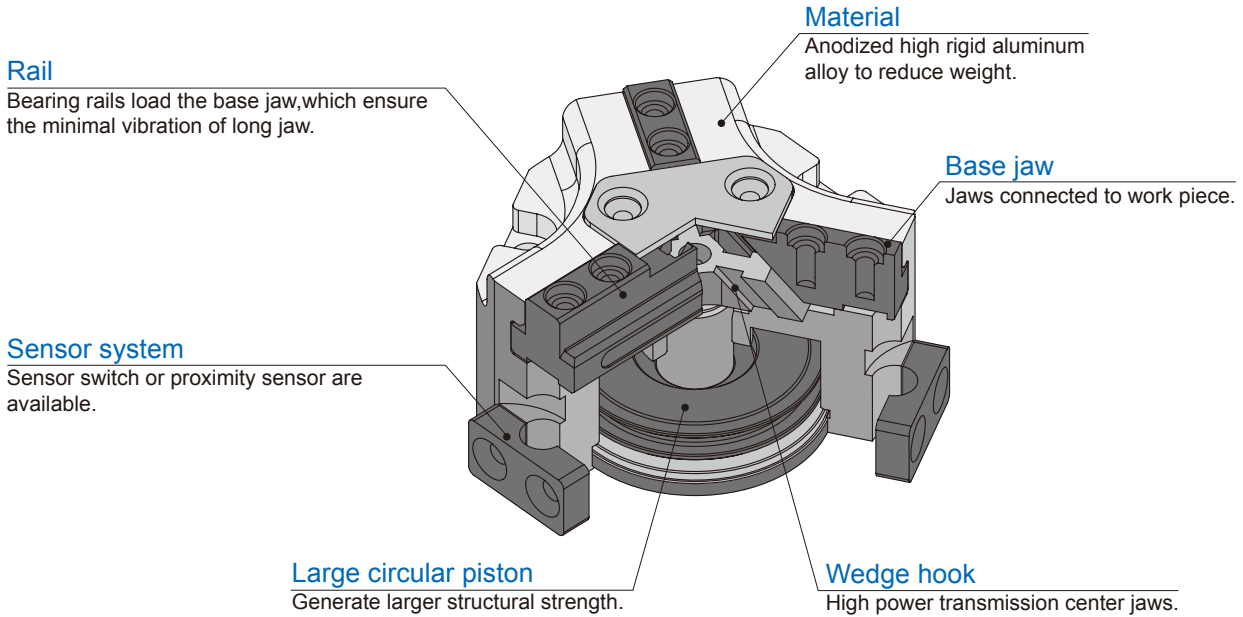

### Application examples

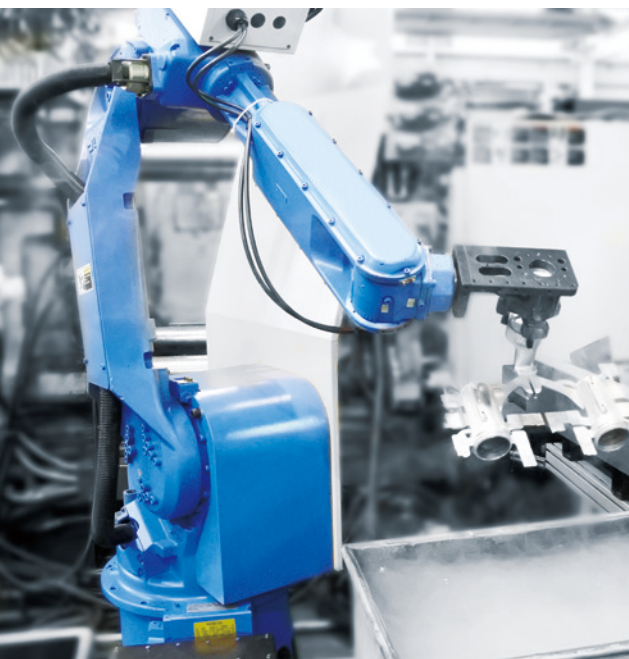

### Hose-free direct connection

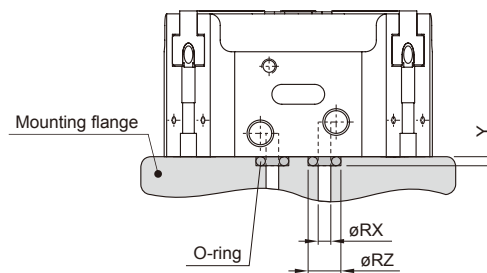

Code Spec.	Q	RX	RZ	Y
50	M3	3	5	0.7
66	M5	5	8	1.2
80	M5	5	8	1.2
100	M5	5	8	1.2
125	M5	5	8	1.2
160	M5	5	8	1.2
200	M6	6	9	1.2
300	G1/8	8.5	12.1	1.8

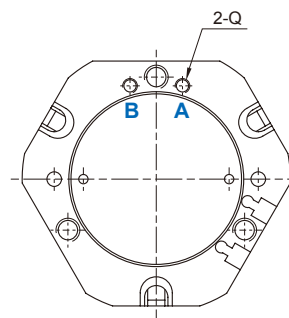

A hole: Gripper close  
B hole: Gripper open

## PARALLEL GRIPPER (3-Finger)

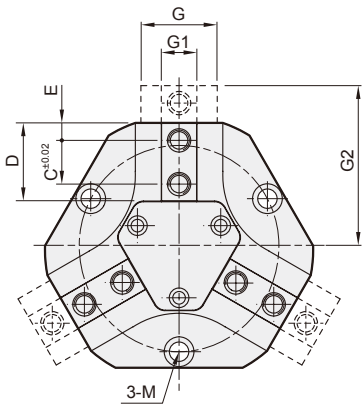

A hole: Gripper close  
B hole: Gripper open  
S hole: External vents

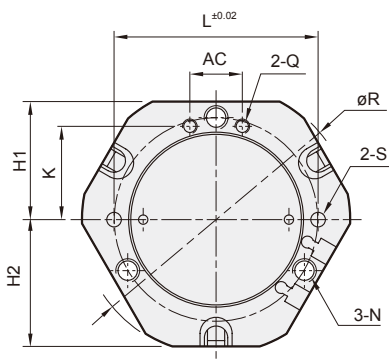
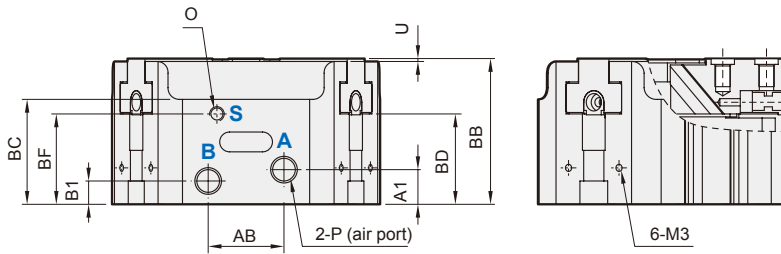

### MCHJ-125~300

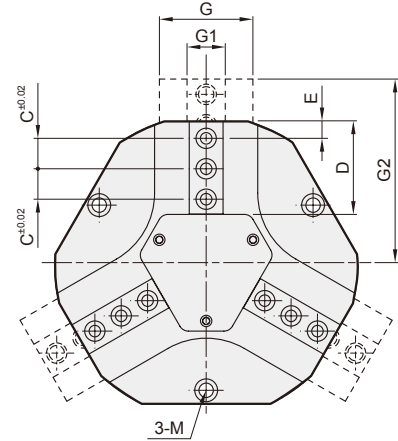

### Centering sleeve

#### MCHJ-50~100

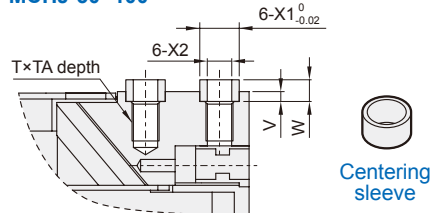

#### MCHJ-125~300

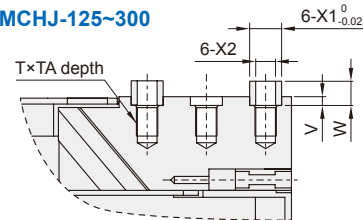

Code Spec.	A1	AB	AC	B1	BB	BC	BD	BF	C	D	E	G	G1	G2	H1	H2	K	L
50	5	12	12	5	35	26	23	23	8	16	4	12	6.5	31	26	27	19	45
66	11.5	12	18	5	43	32	27	27	12	22	5	17	10	41	33	35	25	56
80	8	26	18	8	50	36	31	31	15	26.7	6	22	12	51.5	40.5	43.5	32	70
100	13.5	24	24	10	60	41	38	34	18	34.2	10	26	14	64	51	54	42	90
125	17	30	30	10	68	49	42.5	37	12.5	42.3	10	31	15.5	79	64	67	53	112
160	20	44	38	10.5	80	55	48	45	18	54.8	10	39	20	102	81	86	67.5	146
200	29	54	54	19.5	107	82	68	64	22	67.5	12	42	22	126	100	106	75	180
300	36.1	80	80	29.1	153.1	105.1	101.1	87.1	30	91	15	66	32	172	132.5	142	105	240

Code Spec.	M	N	O	P	Q	R	S	T	TA	U	V	W	X1	X2
50	ø7.3×4.1dp, ø4.3 thru, P.C.D.ø45	M5×0.8×8dp	M3	M5×0.8	M3	57	ø4H7×5	6-M3×0.5	7	1	2	3.9	ø5	ø3
66	ø9×5.1dp, ø5.1 thru, P.C.D.ø56	M6×1.0×10dp	M5	M5×0.8	M5	74	ø4H7×8	6-M4×0.7	8	1	2	3.9	ø6	ø4
80	ø10.2×6.1dp, ø6.8 thru, P.C.D.ø70	M8×1.25×12dp	M5	G1/8	M5	92	ø5H7×8	6-M6×1.0	10	1	2	3.9	ø8	ø6
100	ø10.5×6.5dp, ø6.8 thru, P.C.D.ø90	M8×1.25×12dp	M5	G1/8	M5	114	ø5H7×8	6-M6×1.0	12	1	2	3.9	ø10	ø6
125	ø13.5×8.1dp, ø8.6 thru, P.C.D.ø112	M10×1.5×15dp	M5	G1/8	M5	139	ø6H7×10	9-M6×1.0	14	1	2	3.9	ø10	ø6
160	ø13.5×8.1dp, ø8.5 thru, P.C.D.ø146	M10×1.5×24dp	M5	G1/8	M5	179	ø6H7×10	9-M8×1.25	14	1	2	3.9	ø12	ø8
200	ø17×10.5dp, ø10.3 thru, P.C.D.ø180	M12×1.75×25dp	M5	G1/4	M5	218	ø10H7×19	9-M10×1.5	20	1	2.5	4.9	ø14	ø10
300	ø18.5×12.2dp, ø12.5 thru, P.C.D.ø240	M16×2.0×39.1dp	M5	G1/4	G1/8	292	ø10H7×19	9-M12×1.75	20	2	2.5	4.9	ø18	ø12

## PARALLEL GRIPPER (3-Finger)

- For dusty environment usage.
- When installing soft-jaws, the length of jaws are measured from the the body surface.
- Heat resistance type of modules are also available. Please contact our sales department.

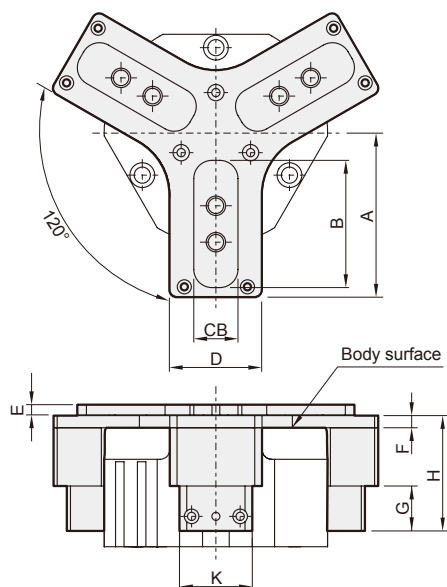

Code Spec.	A	B	CB	D	E	F	G	H	K
50	43	30	13	17	4.5	5	16	35.5	17
66	51	41	16.2	24	4.5	5	19.5	45.5	24
80	67.5	52.4	18.1	38	4.5	5	19	48	30
100	80	61	22	37	4.5	5	11.5	41	37
125	95	72	22	50	4.5	5	14.5	47.5	37
160	121	93	25	60	4.5	6	13	55	50



## GRIPPER

Gripper play an important role in automation systems. Mindman provides various kinds of stable gripper for different applications.





*Connect with*

## AIR CYLINDER

Connect gripper with cylinder to achieve regular workpiece gripping.

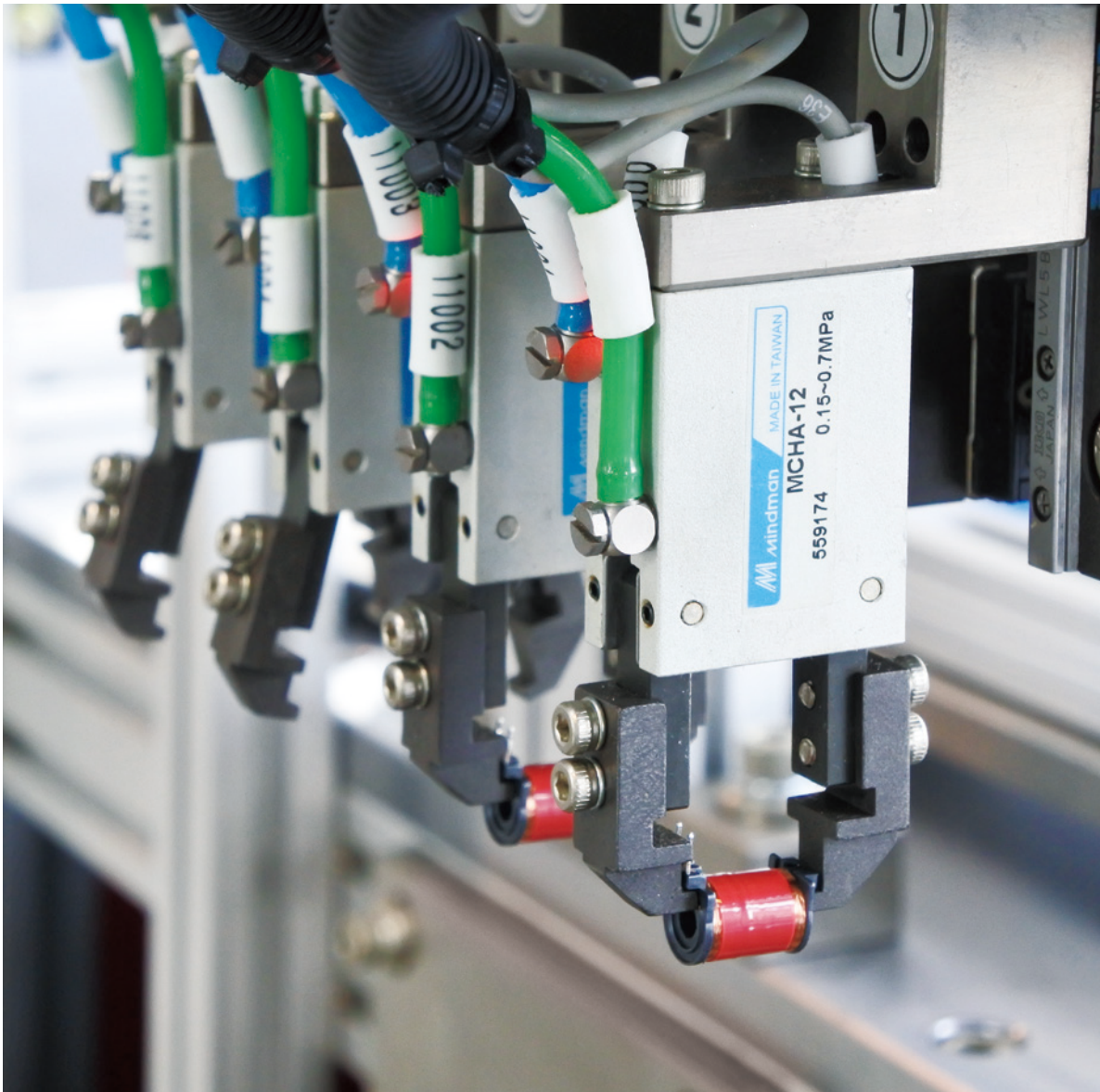



### Features

- Hardened gripping fingers for longer service life.
- Simple structure with high stability.
- Magnetic as standard.

### Specification

Model		MCHA				
Acting type		Double acting / Single acting (N.O.)				
Tube I.D. (mm)		12	16	20	25	32
Port size		M3×0.5	M5×0.8			
Medium		Air				
Operating pressure range	Double acting	0.15~0.7 MPa				
	Single acting	0.3~0.7	0.2~0.7 MPa			
Ambient temperature		-5~+60°C (No freezing)				
Max. operating frequency (c.p.m)		180				
Lubrication	Cylinder	Not required				
	Lever	Grease (Joint parts)				
Max. arm length (L) (*1)		30	40	60	70	85
Clamp / Release angle		-10~+30°				
Sensor switch (*2)		RDE, RDE-D: Non-contact				
Weight (g)		53	103	193	327	525

### Order example

MCHA - 20 - □

MODEL

TUBE I.D.

ACTING TYPE

Blank: Double acting  
S: Single acting (Normally open)

12  
16  
20  
25  
32

\*1. L: Arm length (mm)

\*2. RDE, RDE-D specification, please refer to page 89.

### Installation of sensor switch

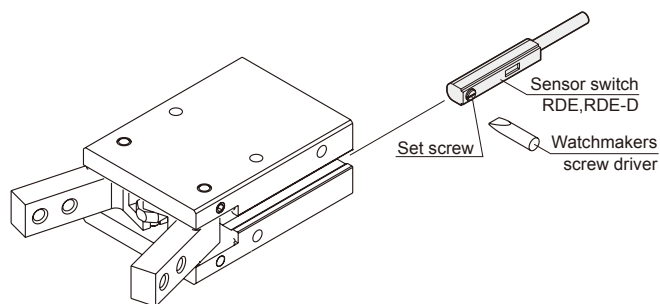

### Double acting

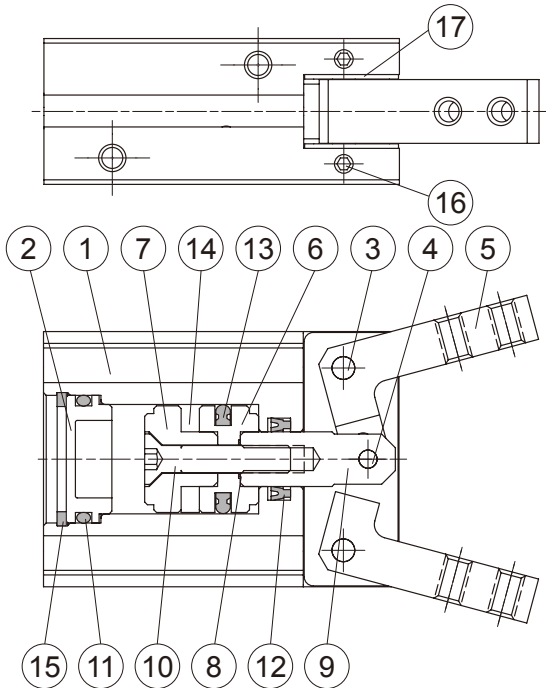

### Single acting

### Normally Open

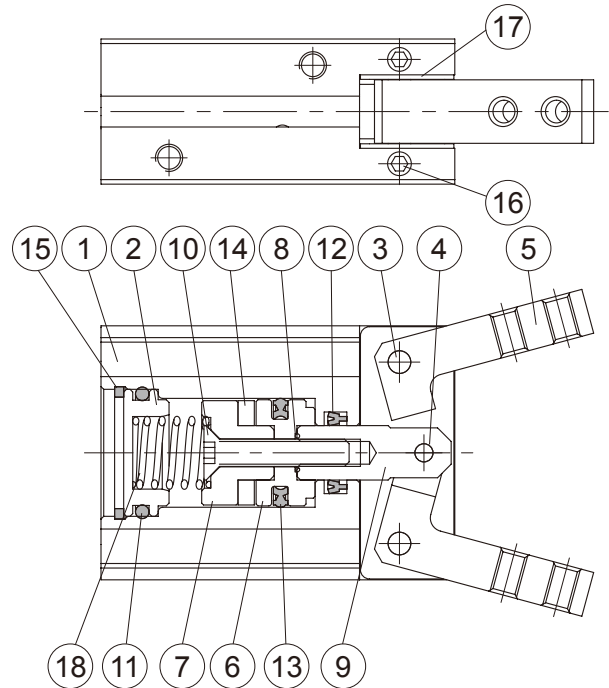

### Material

No.	Part name	Material	Q'y	Repair kits (inclusion)
1	Body	Aluminum alloy	1	
2	Head cover	Aluminum alloy	1	
3	Grip rivet	Carbon steel	2	
4	Spindle rivet	Bearing steel	1	
5	Y-finger	Medium carbon steel	2	
6	Piston-R	Aluminum alloy	1	
7	Piston-H	Aluminum alloy	1	
8	Gasket	NBR	1	●
9	Piston rod	Stainless steel	1	
10	Screw	Stainless steel	1	
11	Cover ring	NBR	1	●
12	Rod packing	NBR	1	●
13	Piston packing	NBR	1	●
14	Magnet ring	Magnet material	1	
15	Stop ring	Spring steel	1	
16	Screw	SCM	4	
17	Washer	Stainless steel	2	
18	Spring	SWB-P	1	

### Order example of repair kits

Tube I.D.	Repair kits
ø12	<b>PS-MCHA-12</b>
ø16	<b>PS-MCHA-16</b>
ø20	<b>PS-MCHA-20</b>
ø25	<b>PS-MCHA-25</b>
ø32	<b>PS-MCHA-32</b>

### Effective gripping force

Indication of effective force.  
The effective gripping force shown in the graphs to the right is expressed as F, which is the thrust of one finger, when both fingers and attachments are in full contact with the workpiece as shown in the figure below.

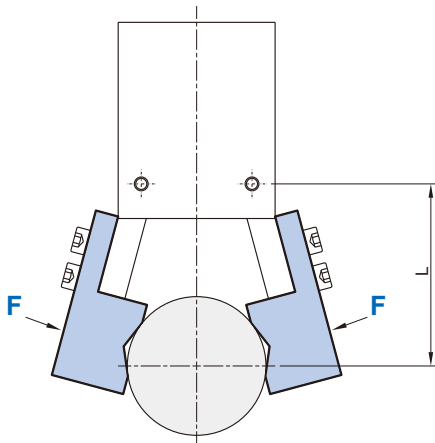

1N=0.102 kgf  
1MPa=10.2 kgf/cm<sup>2</sup>

### Double acting

#### MCHA-12

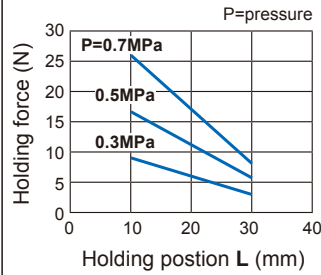

#### MCHA-16

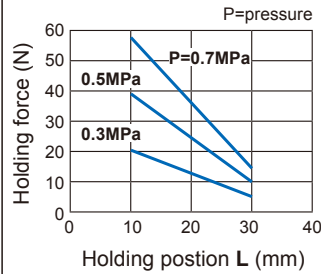

#### MCHA-20

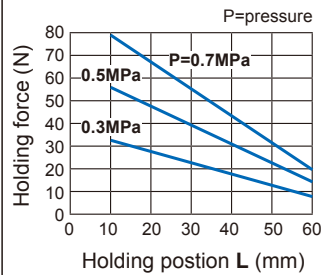

#### MCHA-25

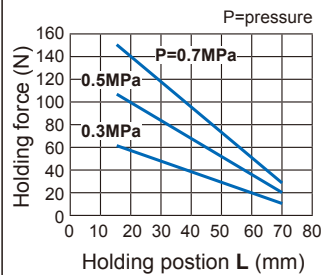

#### MCHA-32

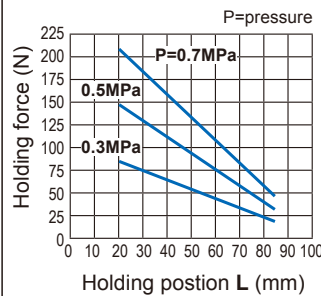

### Single acting (Normally open)

#### MCHA-12-S

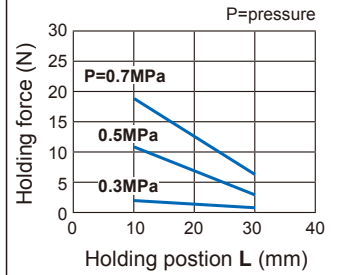

#### MCHA-16-S

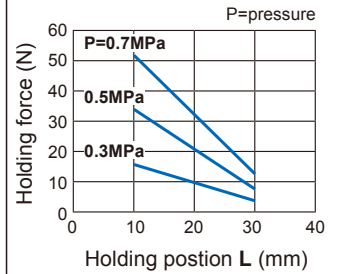

#### MCHA-20-S

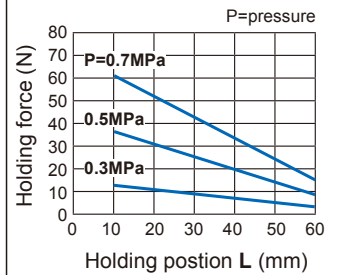

#### MCHA-25-S

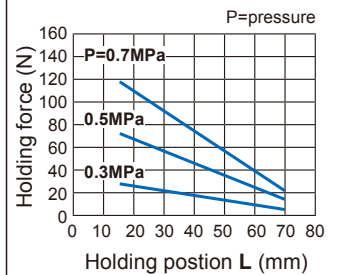

#### MCHA-32-S

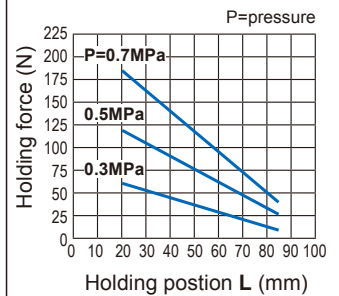

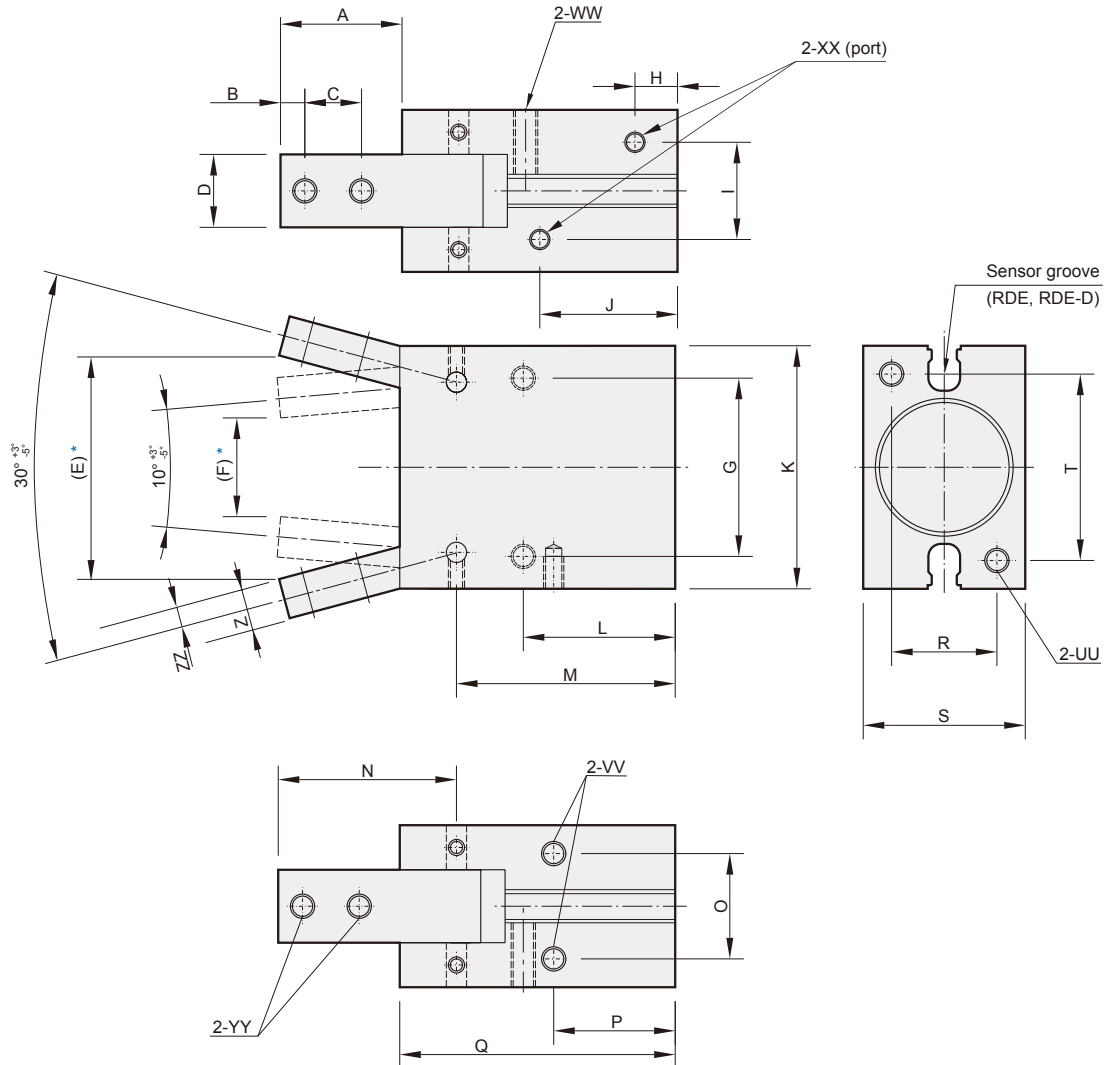

\* Reference value.

Code Tube I.D.	A	B	C	D	E	F	G	H	I	J	K	L	M	N	O	P	Q	R	S	T	UU	VV
12	15.4	3	6	7	26.3	9	20	7.5	10.2	23	28	20	32.9	21.5	10.2	16	39	10	16	22	M3×5depth	M3×5depth
16	17.5	3	8	9	31.1	14	24	7.5	12	22	34	22.5	35	25	14	18	42.5	14	22	26	M4×7depth	M4×7depth
20	22	4	10	12	40.1	18	30	8.0	13	25	45	25	39.5	32.5	16	19	50	16	26	35	M5×8depth	M5×8depth
25	26	5	12	14	47.9	21	36	8.5	18	28	52	28.5	45.5	38.5	20	21.5	58	20	32	40	M6×10depth	M6×8depth
32	30	6	14	18	55.1	24	44	10.5	24	34	60	37.5	54	44	26	30	68	26	40	46	M6×10depth	M6×8depth

Code Tube I.D.	WW	XX	YY	Z	ZZ
12	M3×8depth	M3×5 depth	M3	5	2.5
16	M4×11depth	M5×5 depth	M3	6	3
20	M5×12depth	M5×5 depth	M4	7	3.5
25	M6×16depth	M5×5 depth	M5	9	4
32	M6×20depth	M5×5 depth	M6	10	5



*Connect with*

---

## *AUTOMATIC ASSEMBLY MACHINE*

Connect gripper with cylinder to achieve regular workpiece gripping.

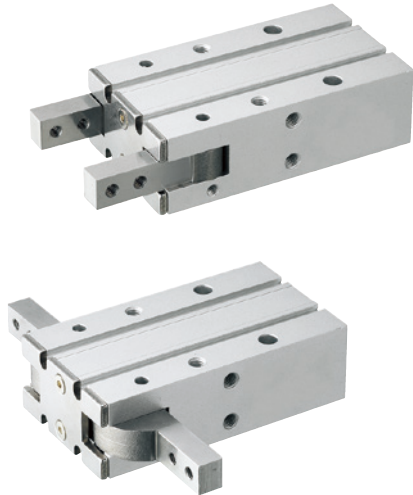

### Order example

**MCHY – 16 D 1**

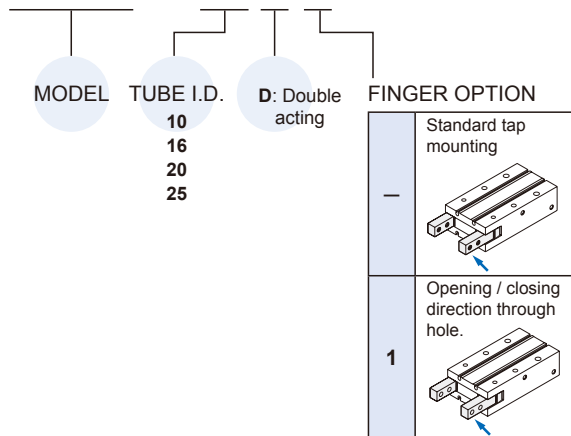

**Fig1.** Reduced required offset while moving gripper

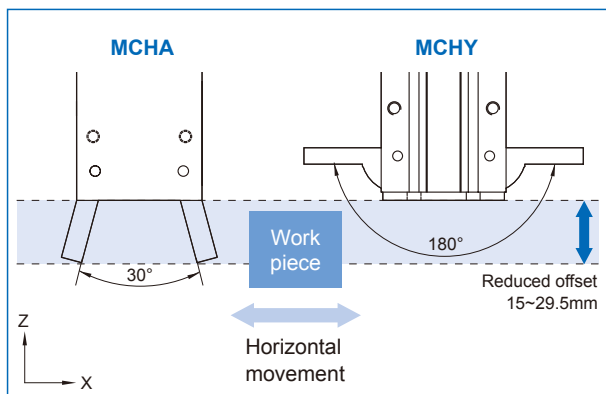

### Features

- Compact design and lightweight construction.
- High gripping forces achieved via internal cams. Reduced required offset while moving gripper. (Fig1).
- Reference points on gripping fingers are standard.
- Sensors can be mounted in any one of four positions.
- Rod seal prevents foreign objects to enter piston.
- Magnetic as standard.

### Specification

Model	MCHY			
Acting Type	Double acting			
Tube I.D. (mm)	10	16	20	25
Medium	Air			
Operating pressure range	0.2~0.6 MPa			
Ambient temperature	-10~+60°C (No freezing)			
Repeatability	±0.2 mm			
Max. operating frequency (c.p.m)	60 (*1)			
Lubrication (*2)	Not required			
Effective force (Nm) at (0.5 MPa)	0.16	0.54	1.1	2.28
Operating angle (both sides)	Opened side	180°~182°		
	Closed side	-3°		
Sensor switch (*3)	2 wire	RDVE(V): Non-contact		
	3 wire	RNFE(V): NPN, RPFE(V): PNP		
Weight (g)	80	150	320	600

\*1. Speed adjust components are required while in use.

\*2. Sliding area of jaws need scheduled relubrication.

\*3. R\*FE(V) specification, please refer to page 90.

### Installation of sensor switch & speed controller

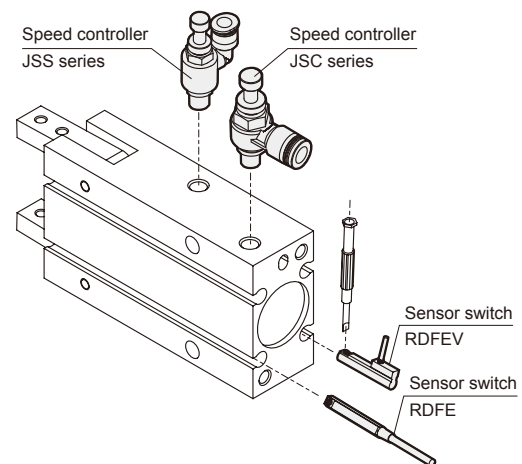

\* Each gripper needs at least two speed control valves to operate.

\* Speed controller specification, please refer to Mindman website.

ø10

ø16~ø25

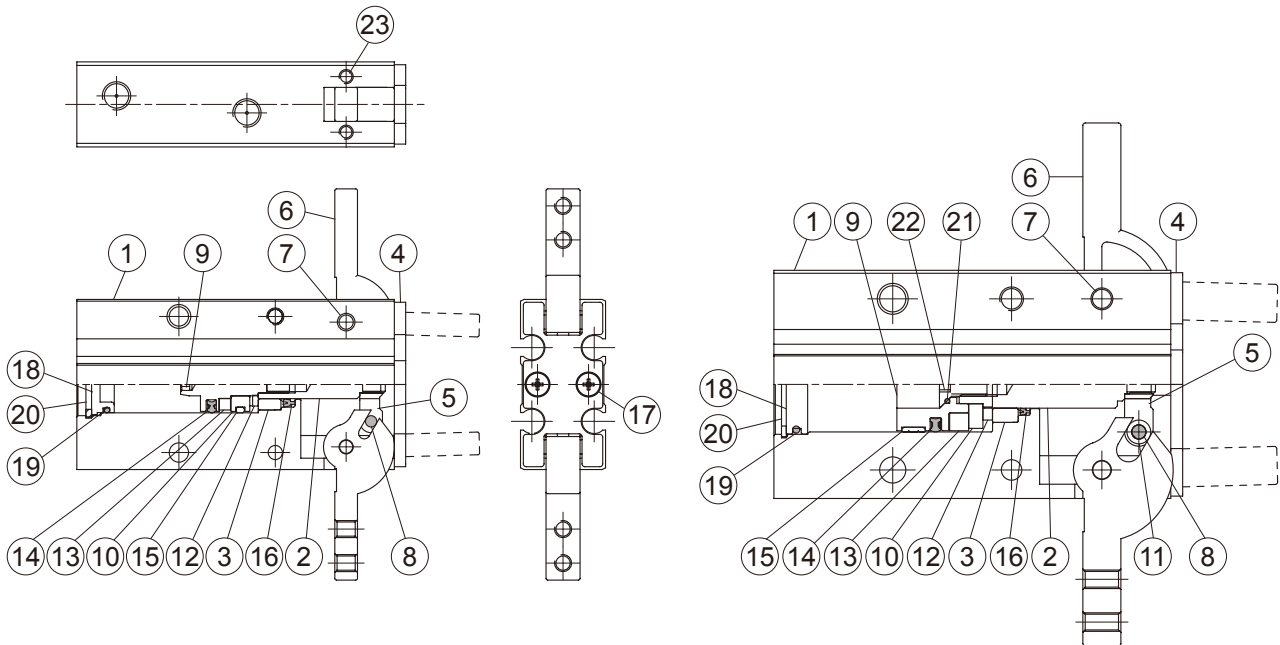

### Material

No.	Tube I.D. Part name	10	16	20	25	Q'y	Repair kits (inclusion)
1	Body	Aluminum alloy				1	
2	Piston rod	Stainless steel				1	
3	Bushing	Brass				1	
4	Head cover	Stainless steel				1	
5	Lever	Stainless steel				1	
6	Gripper	Stainless steel				2	
7	Grip rivet	Carbon steel				2	
8	Pin	Carbon steel				2	
9	Piston	*1	Aluminum alloy			1	
10	Magnet holder	Stainless steel				1	
11	Pin bushing	-		SCM		2	
12	Cushion pad	NBR	PU			1	●
13	Magnet ring	Magnet material				1	
14	Piston packing	NBR				1	●
15	Wear ring	Resin				1	
16	Rod packing	NBR				1	●

No.	Tube I.D. Part name	10	16	20	25	Q'y	Repair kits (inclusion)
17	Screw	Stainless steel				2	
18	Rod cover	Aluminum alloy				1	
19	O-ring	NBR				1	●
20	Snap ring	*2	Stainless steel			1	
21	O-ring	-		NBR		1	●
22	Hexagon Bolt	-		Stainless steel		1	
23	Scew	Stainless steel				4	

\*1. Stainless steel \*2. Carbon steel

### Order example of repair kits

Tube I.D.	Repair kits
ø10	<b>PS-MCHY-10</b>
ø16	<b>PS-MCHY-16</b>
ø20	<b>PS-MCHY-20</b>
ø25	<b>PS-MCHY-25</b>

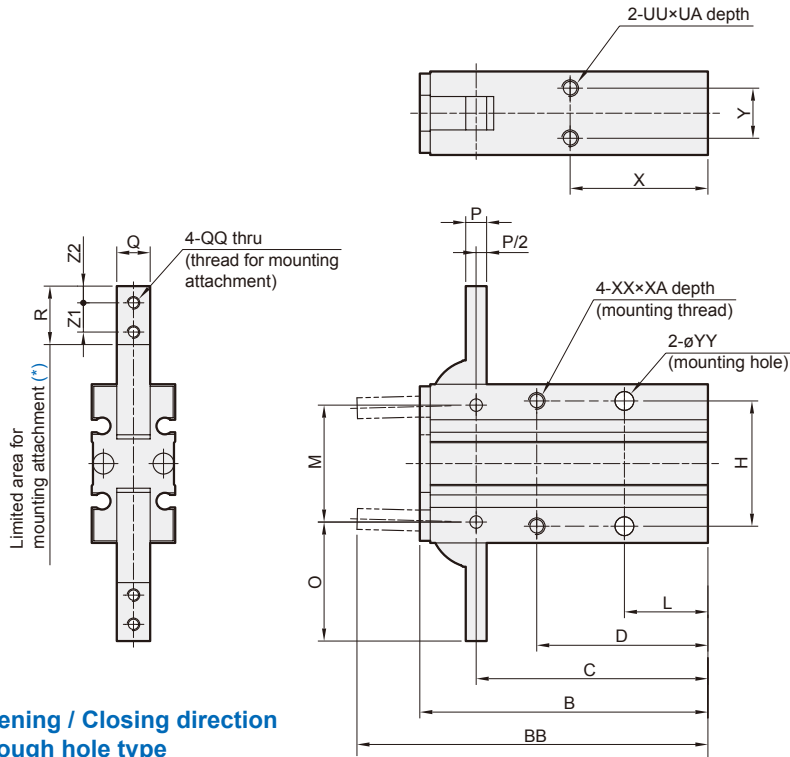

### Pin hole positioning

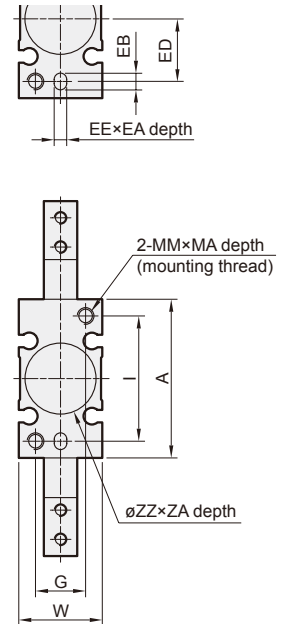

### Opening / Closing direction through hole type

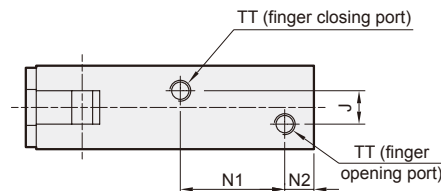
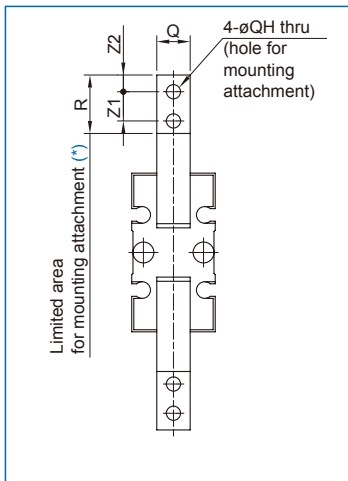

### Auto switch mounting groove position

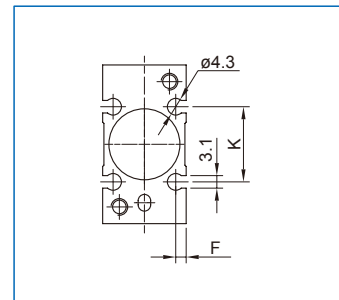

\* Do not extend the attachment from limited area for mounting to avoid interference with the attachment or main body.

Code Tube I.D.	A	B	BB	C	D	EE	EA	EB	ED	F	G	H	I	J	K	L	M	MA	MM	N1	N2	O	P	Q	QH	QQ
10	30	58	71	47.5	35	3H9 <sup>+0.025</sup> <sub>-0</sub>	3	4	9	2	9	24	24	3	13	18	22	6	M3×0.5	23	7	23.5	4	6 <sup>-0.005</sup> <sub>-0.025</sub>	3.4	M3×0.5
16	38	69	84	55.5	41	3H9 <sup>+0.025</sup> <sub>-0</sub>	3	4	15	2.5	12	30	30	8	18	20	28	8	M4×0.7	25	7	28.5	5	8 <sup>-0.005</sup> <sub>-0.025</sub>	3.4	M3×0.5
20	48	86	106	69	50	4H9 <sup>+0.030</sup> <sub>-0</sub>	4	5	19	3	16	36	38	12	20	25	36	10	M5×0.8	32	8	37	8	10 <sup>-0.005</sup> <sub>-0.025</sub>	4.5	M4×0.7
25	58	107	131	86	60	4H9 <sup>+0.030</sup> <sub>-0</sub>	4	5	23	3	18	42	46	14	24	30	45	12	M6×1	42	8	45	10	12 <sup>-0.005</sup> <sub>-0.025</sub>	5.5	M5×0.8

Code Tube I.D.	R	TT	UA	UU	W	X	XA	XX	Y	YY	ZA	ZZ	Z1	Z2
10	12	M5×0.8	4	M3×0.5	15	30	6	M3×0.5	9	3.4	1.5	11H9 <sup>+0.043</sup> <sub>-0</sub>	6	3
16	14	M5×0.8	5	M4×0.7	20	33	8	M4×0.7	12	4.5	1.5	17H9 <sup>+0.043</sup> <sub>-0</sub>	7	4
20	18	M5×0.8	8	M5×0.8	26	42	10	M5×0.8	14	5.5	1.5	21H9 <sup>+0.052</sup> <sub>-0</sub>	9	5
25	22.5	M5×0.8	10	M6×1	30	50	12	M6×1	16	6.6	1.5	26H9 <sup>+0.052</sup> <sub>-0</sub>	12	6





### Order example

\* Special order is available.

**RCE** — □

#### MODEL

- RCE: Reed Switch
- RDE: Non-contact
- RDE-D: Non-contact, two indicators
- RNE: NPN
- RNEE: NPN
- RPE: PNP
- RPEE: PNP

#### WIRE LENGTH

- Blank: L=2000mm
- 1M: L=1000mm
- QD: M8, 3 Pin connector
- EQD: M8, 3 Pin connector

### Assembling style

Cylinder type	Mounting clamp
MCHA, MCHB, MCHC	

### Dimension

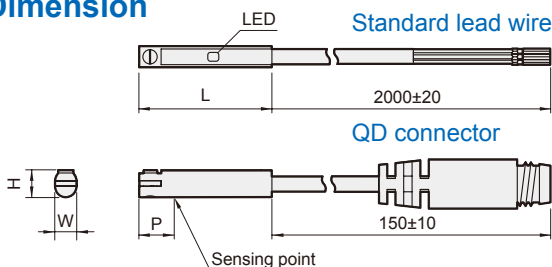

### Wiring of the QD

- 2 wire QD wiring
- 2 wire EQD wiring
- 3 wire QD wiring

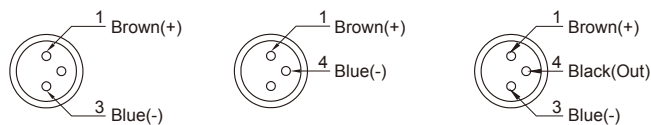

Code Model	H	L	P	W
RCE	5	24	12	4
RDE, RDE-D	5	24	6	4
RNE, RPE	4.65	22	6	4.1
RNEE, RPEE	5	22	6	4

### Specification

Model	RCE	RDE	RDE-D	RNE	RNEE	RPE	RPEE
Wiring method	2 wire			3 wire			
Switching logic	SPST normally open			Solid state output, normally open			
Switch Type	Reed switch	Non-contact		NPN current sinking		PNP current sourcing	
Operating voltage	5~220V DC/AC		10~28V DC	5~30V DC			
Switching current	50mA max.	50mA max.	80mA max.	50mA max.	200mA max.	50mA max.	200mA max.
Switching rating(*1)	10W max.	1.5W max.	2W max.	1.5W max.	6W max.	1.5W max.	6W max.
Current consumption	—			10 mA@24V DC max.	6 mA@24V DC max.	12 mA@24V DC max.	6 mA@24V DC max.
Voltage drop	3.5V max.		4V max.	0.5V max.	0.5V @200mA max.	1.5V max.	0.5V @200mA max.
Leakage current	—	0.1mA max.	1mA max.	0.01mA max.			
Indicator (LED)	Red		Red/Green	Red		Green	
Cable	ø2.8,2C,PUR	ø2.8,2C,PUR		ø3, 3C, PU			
Temperature range	-10~+70°C (No freezing)						
Shock (*2)	30G			50G			
Vibration (*3)	9G						
Enclosure classification	IEC 60529 IP67						
Protection circuit (*4)	1	3,4	2,3,4	3,4			
Weight	20 g (2m cable)						
Connect diagram							

\*1. Warning: Never exceed rating (watt=voltage×amperage). Permanent damage to sensor will occur.

\*2. Sin wave / X.Y.Z. 3 directions / 3 times each direction / 11ms each time.

\*3. Double amplitude 1.5mm / 10Hz~55Hz~10Hz(Sweep 1min) / X.Y.Z. 3 directions / 1 hour each time.

\*4. 1=None / 2=Short-circuit / 3=Power source reverse polarity / 4=Surge suppression

\*5. Caution for safety please refer to page 96.



### Order example \* Special order is available.

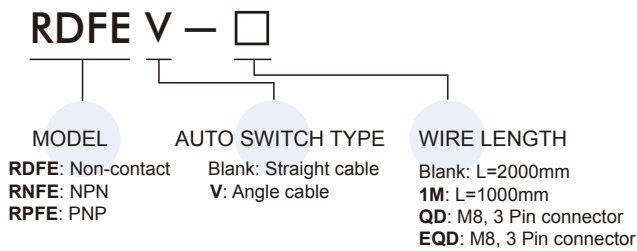

### Assembling style

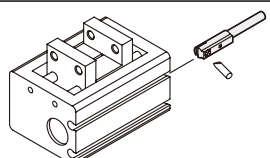
Cylinder type	Mounting clamp
<b>MCHC-6, MCHD, MCHH, MCHU, MCHS, MCHX, MCHG2, MCHJ, MCHY</b>	

### Dimension

#### Straight cable

#### Angle cable

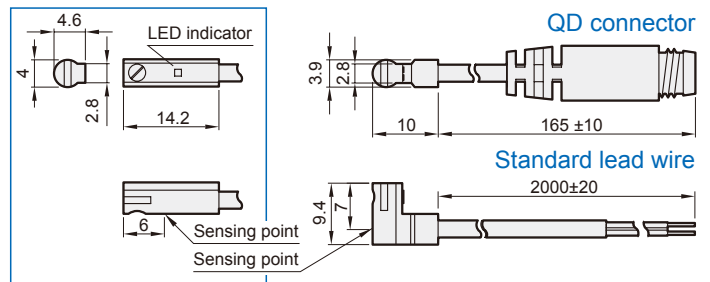

### Wiring of the QD

- 2 wire QD wiring
- 2 wire EQD wiring
- 3 wire QD wiring

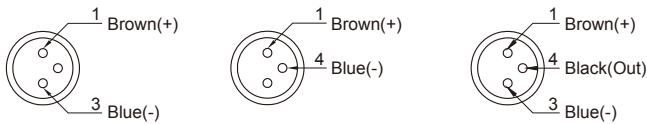

### Specification

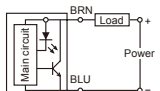
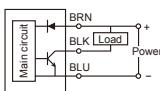
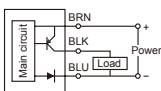
Model	RDFE / RDFEV	RNFE	RNFEV	RPFE	RPFEV
Wiring method	2 wire	3 wire			
Switching logic	Solid state output, Normally open				
Switch Type	Non-contact	NPN current sinking		PNP current sourcing	
Operating voltage	5~30V DC	5~30V DC		5~30V DC	
Switching current	50mA max.	50mA max.	80mA max.	50mA max.	80mA max.
Contact rating(*1)	1.5W max.	1.5W max.	2.2W max.	1.5W max.	2.2W max.
Current consumption	—	10mA @24V DC max.	6mA @24V DC max.	10mA @24V DC max.	6mA @24V DC max.
Voltage drop	3.5V max.	0.5V @ 50mA max.			
Leakage current	0.1mA(40uA) max.	0.01mA max.			
Indicator	Red LED				
Cable	ø2.6, 2C, PVC	ø2.6, 3C, PVC			
Operating Frequency	1000 Hz				
Temperature range	-10~+70°C (No freezing)				
Shock (*2)	50G				
Vibration (*3)	9G				
Enclosure classification	IEC 60529 IP67				
Protection circuit (*4)	3, 4				
Weight	12.8 g (1m cable) / 23.8 g (2m cable)				
Connect diagram					

\*1. Warning: Never exceed rating (watt=voltage×amperage). Permanent damage to sensor will occur.  
 \*2. Sin wave / X.Y.Z. 3 directions / 3 times each direction / 11ms each time.  
 \*3. Double amplitude 1.5mm / 10Hz~55Hz~10Hz(Sweep 1min) / X.Y.Z. 3 directions / 1 hour each time.  
 \*4. 1=None / 2=Short-circuit / 3=Power source reverse polarity / 4=Surge suppression  
 \*5. Caution for safety please refer to page 96.



### Order example

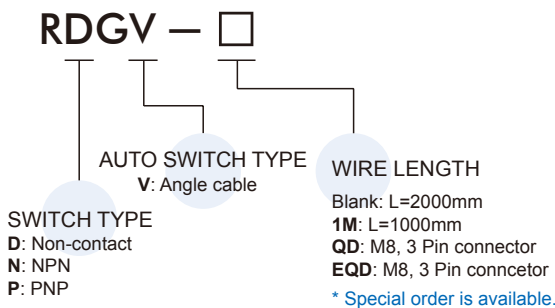

### Specification

Model	RDGV	RNGV	RPGV
Wiring method	2 wire	3 wire	
Switching logic	Solid state output, Normally open		
Switch type	Non-contact	NPN current sinking	PNP current sourcing
Operating voltage	10~28V DC	5~28V DC	
Switching current	4~20mA max.	50mA max.	
Contact rating (*1)	0.6W max.	1.5W max.	
Current consumption	—	10mA @24V DC max.	
Voltage drop	3.5V max.	0.5V @ 50mA max.	
Leakage current	0.8mA max.	0.01mA max.	
Indicator	Red LED		
Cable	∅2.6, 2C, PVC	∅2.6, 3C, PVC	
Operating Frequency	1000 Hz		
Temperature range	-10°C~+70°C (No freezing)		
Shock (*2)	50G		
Vibration (*3)	9G		
Enclosure classification	IEC 60529 IP67		
Protection circuit (*4)	4	3, 4	
Weight	23 g (2m cable)		
Connect diagram			

### Dimension

#### RDGV / RNGV / RPGV

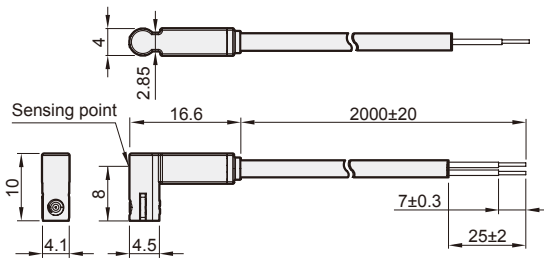

#### RDGV-QD / RNGV-QD / RPGV-QD

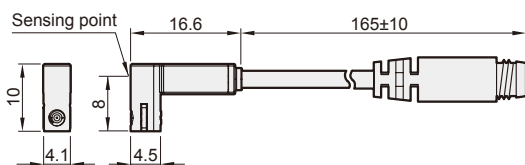

### Wiring of the QD

#### • 2 wire QD wiring

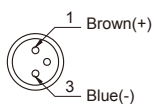

#### • 2 wire EQD wiring

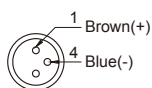

#### • 3 wire QD wiring

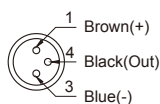

### Assembling style

Cylinder type	Mounting clamp
<b>MCHJ-50</b>	

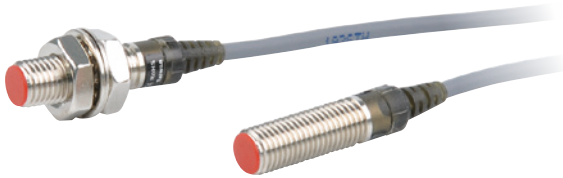

### Order example

**RDP8 — N — 3M**

MODEL SWITCH TYPE WIRE LENGTH  
 N: NPN  
 P: PNP  
 3M: 3000mm

### Specification

Model	RDP8
Operating voltage	10~30V DC
Power ripple	20% peak to peak
Current consumption	10mA max.
Detection distance	1.8~2.0 mm for steel 0.4~0.6mm for aluminum
Hysteresis	10% of sensing distance max.
Response frequency	2.5KHz min.
Output type	NPN, PNP
Output logic	N.O.
Output current	150mA max.
Residual voltage	0.1V max.
Leakage current	0.8mA max.
Protection type	Short circuit & polarity reversed protection
Indicator (LED)	White
Cable length	3m±0.1 m
Cable	3c/ø3, gray cover, oil and shaking resistance
Maximum voltage resistance	2.5kv / 1 minute min.
Operating environment	-20°C ~ +80°C, 35% ~ 85% RH
Protection class	IP 67

\* Caution for safety please refer to page 96.

### Dimension

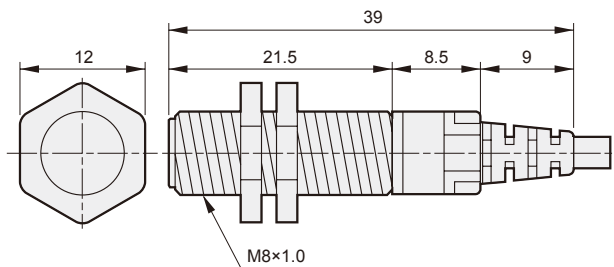

### Assembling style

Cylinder type	Mounting clamp
MCHJ, MCHS	

### Connect diagram

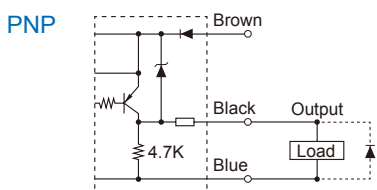
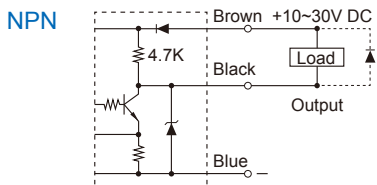





## PLEASE READ BEFORE USING

Before selecting model and servicing of the product, read throughly this CAUTIONS for SAFETY for the proper usage.

- The following cautions are for the purpose of preventing your personnel from suffering injury, by following the proper usage of the products.
- Items are classified in three categories, DANGER, WARNING, and CAUTION. All items are crucial for the safety and need to be followed without exception.

<b>DANGER</b> 	Obviously dangerous, which may cause death or serious injury of personnel, and damage or destruction of property.
<b>WARNING</b> 	Not immediately subject to danger, however not avoiding the displayed danger when mishandling the product may cause death or serious injury of personnel and damage or destruction of property.
<b>CAUTION</b> 	Not immediately subject to danger, however not avoiding the displayed danger when mishandling the product may cause injury of personnel and damage or destruction of property.

For the correct handling, please read the instruction manual before installing and servicing of the product.

### DANGER

(Applies to all products on the catalogue)

- 1 Do not use any of our products for the purpose of maintenance and care of human life or body.
- 2 Do not use any product in the condition or the environment other than stipulated in the specification or where the hazardous stuff exists.
- 3 When installing a product, refer to the instruction manual for mounting style and fix securely (including the work carrier). Otherwise products may topple, fall, and operates out of control causing the injury of personnel.
- 4 Disassembling and reassembling of products should be made by the personnel who has enough knowledge and experience.
- 5 Depressurize products before disassembling or reassembling.
- 6 Do not remodel the products.

### WARNING

(Applies to all products on the catalogue)

- 1 When servicing, keep within the working pressure range and voltage.
- 2 At a place where water or oil drops and where is much dust, cover the equipment. Otherwise damage and trouble will be caused.
- 3 Do not operate if the fluid or atmosphere contains the substance which may cause corrosion. Otherwise damage and trouble will be caused.
- 4 Do not touch the terminal part or switches, etc. when the product is energized. It may cause the inaccurate operation and the electric shock from the short circuit and the circuit trouble.
- 5 Do not stand on, use as a footing, or put things on the product. You may miss your step and fall, and the falling product may cause the injury of personnel. Also the product may get damaged causing the inaccurate operation and hazardous moves out of control.

(Pneumatic Actuator)

- 1 When starting operation, pay the full attention to the cylinder's moving direction.
- 2 Do not put hands where the cylinder moves.
- 3 Please use a speed control valve to adjust the piston speed within the limited value in our catalogue.
- 4 The value of dividing operation time into cylinder stroke is the average speed rather than max speed.  
  
The max. speed of cushion pad type cylinders occur at the end of the stroke.  
  
The max. speed of air cushion type cylinders occur at the start point of cushioning structure.
- 5 The max. speed of cylinders usually uses the value of average speed times 1.4~1.5.
- 6 When the load on cylinder is large, we suggest to use ourter shock absorber - even the max speed is within the limited value.
- 7 Cords such as the sensor switch's lead wire should not be damaged. Damaging, forcing, twisting tugging, winding, putting on a heavy object, and pinching will cause fire, electric shock abnormal operation by short circuit or circuit error.

(Pneumatic Valve. Pneumatic Accessories. Sensor Switch)

- 1 Cords such as the pressure switch's lead wire, solenoid valve's power supply cord should not be damaged. Damaging, forcing, twisting, tugging, winding, putting heavy object on, and pinching will cause fire, electric shock, abnormal operation by short circuit or circuit error.
- 2 Do not use filter or lubricator without a case guard.
- 3 For filter and lubricator, do not use a flawed or stained case.

# Caution for safety

**⚠ PLEASE READ BEFORE USING**

## **⚠ CAUTION**

(Applies to all products on the catalogue)

- 1 If necessary, use protection glove, protection glasses, and safety shoes to secure the safety when operating products.
- 2 For the easy maintenance, enough space around the product should be provided.
- 3 When mounting, flush inside thoroughly to remove chips from piping, and seal tape, rust and dusts, in order to prevent troubles such as air leak.
- 4 When screwing in the fittings, fasten with the tie torque of proper size to the connection size.
- 5 Use clean air. Equip an air filter near the equipment to remove drain, dusts and etc. Periodically remove drain from the filter.
- 6 Spindle oil and machine oil must not be used for lubrication, or the swelled packings will cause operation troubles.
- 7 Operation below the temperature 5°C must be paid the full attention since it may cause the freezing of drain.
- 8 Magnetic products such as disk card, tape, and tester must be kept away from the magnet-equipped cylinder and solenoid valve's solenoid part.
- 9 When the product is no longer available for operation or needed, discard in a proper way as an industrial waste.
- 10 Do not throw the product into fire. The product may explode or the toxic gas may be generated.

(Pneumatic Actuator)

- 1 Products should be mounted on the plane face. Mounting on the warped face causes poor accuracy, air leak and troubles.
- 2 Flaw or dent on the mounting part of the cylinder may make the uneven face.
- 3 The chafing parts of piston rod and guide rod must be free from flaw or dent. Otherwise packings got damaged and air will leak.
- 4 When the cylinder draws, be careful not to put yourself between the cylinder and the link bar at the top (Twin guide cylinder).
- 5 Products do not need lubrication since they are initially lubricated. For lubrication, use turbine oil first class (ISO VG32) or the equivalent.
- 6 Sensor switch which senses the cylinder position must not be operated in the magnetically disturbed area. It will react to the magnetism and the sensing accuracy will be disturbed.
- 7 If the two switch-equipped cylinders are mounted close in parallel, a switch may react to the another cylinder's moving magnet, and effects on the sensing accuracy.
- 8 Avoid the load over the switch's allowable maximum load.

(Pneumatic Valve. Pneumatic Accessories. Sensor Switch)

- 1 Flaw or dent on the mounting part of the cylinder may make the uneven face.
- 2 Do not use solenoid valve, pressure switch, flow switch, on foot switch in the environment where the large electric current or the strong magnetism exist.
- 3 As for solenoid valve, check in the instruction manual whether the lubrication is needed. If needed, use turbine oil first class ISO VG32 on the equivalent.
- 4 In the case of double solenoid valve, do not energize both solenoids.
- 5 Avoid the load over the switch's allowable maximum load.

# Caution for safety

## ! SENSOR SWITCH

### Technical information

#### ! CAUTION

Do not exceed specification, permanent damage to the sensor may occur.

1. The 2-wire type magnetic sensor must be connected in series with load. Or the sensor may malfunction.
2. For reed switch type sensors, polarity must also be observed for the proper function of LED. Connect the brown wire in series with load to positive (+) and the blue wire to negative (-) of DC power source. If the polarity is reversed, reed sensor remain functional but LED will remain in "OFF" state.

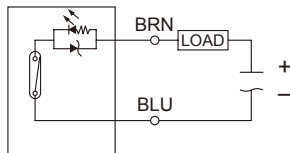

3. For solid-state type sensors, connect brown wire to the positive (+) and the blue to the negative (-) of DC power source. For 3-wire type, the black wire must be connected to the load only. If the black wire is accidentally connected to the power source, sensor may malfunction.

#### 2-wire type

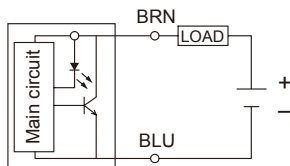

#### 3-wire type

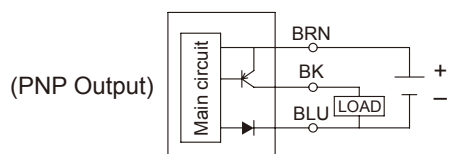
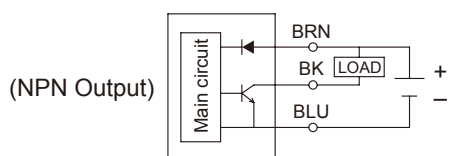

4. An external protection circuit may be required if the magnetic sensor is used with inductive load, such as relay or solenoid. For DC inductive load, attach an external diode parallel to the load and use R-C circuit parallel with AC inductive load as illustrated below.

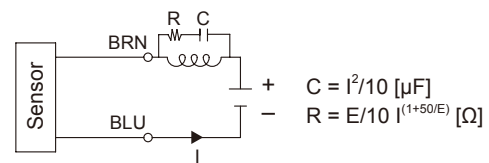
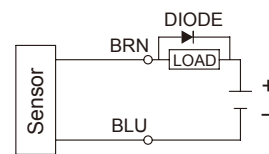

C: Capacitor  
R: Resistance  
I: Load current  
E: AC power

$$C = I^2/10 \text{ } [\mu\text{F}]$$

$$R = E/10 \text{ } |^{(1+50/E)} \text{ } [\Omega]$$

5. Keep sensors away from strong magnetic field to prevent malfunction.
6. Reed sensors are without protection circuit.

When a reed sensor is used with a capacitive load or with more than 5 meters lead wire, the life of the contact will be shortened. (especially when the switch is always ON)

#### Note

Please install a surge suppressor within 1 meter or an inductor (560~1000 $\mu$ H) in series of the sensor to prevent damage.

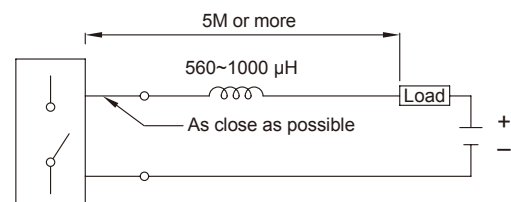

# Caution for safety



mindman

PARALLEL GRIPPER

ANGULAR GRIPPER

SENSOR SWITCH

CAUTION

## ! SENSOR SWITCH

### Connection method

#### 2 wire sensor connection

##### ► General connection

Reed switch

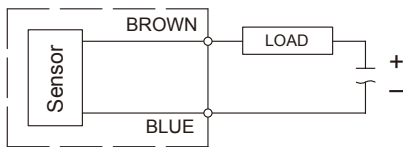

##### Solid-state type

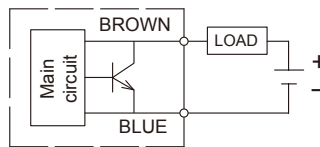

##### PLC

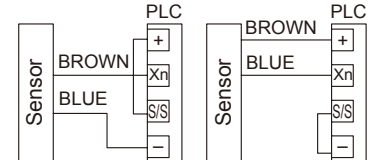

Connection to NPN input module

Connection to PNP input module

##### ► Series connection (AND)

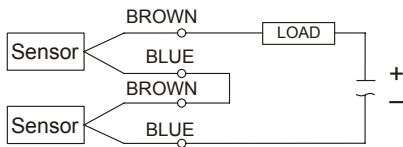

##### Note

1. When connecting 2-wire sensors in series (AND), don't exceed more than two sensors due to the internal voltage drop (Typical V drop=2.5~4V per switch). Excessive Voltage drop will cause the load fail to operate.

##### ► Parallel connection (OR)

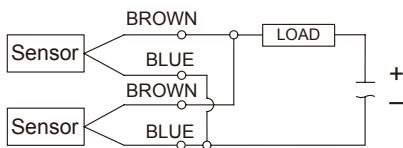

##### Note

1. When connecting solid state 2-wire sensors in parallel (OR), current leakage will increase and cause improper load operation.
2. When connecting two magnetic sensors in parallel (OR), possible concurrent operation will cause dim LED illumination due to lower current distribution.

#### 3 wire NPN connection

##### ► General connection

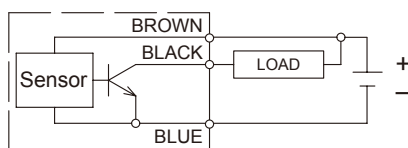

#### 3 wire PNP connection

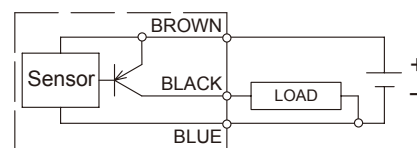

##### ► Series connection (AND)

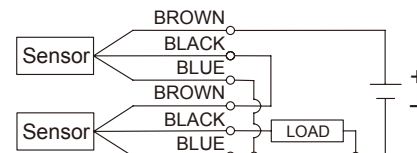
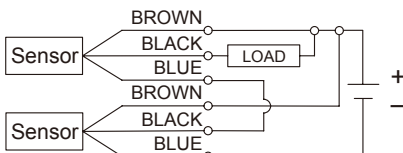

##### ► Parallel connection (OR)

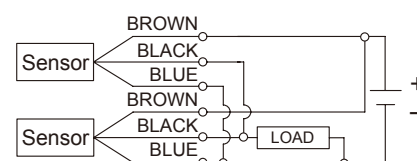
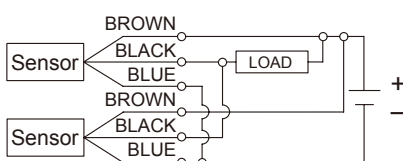

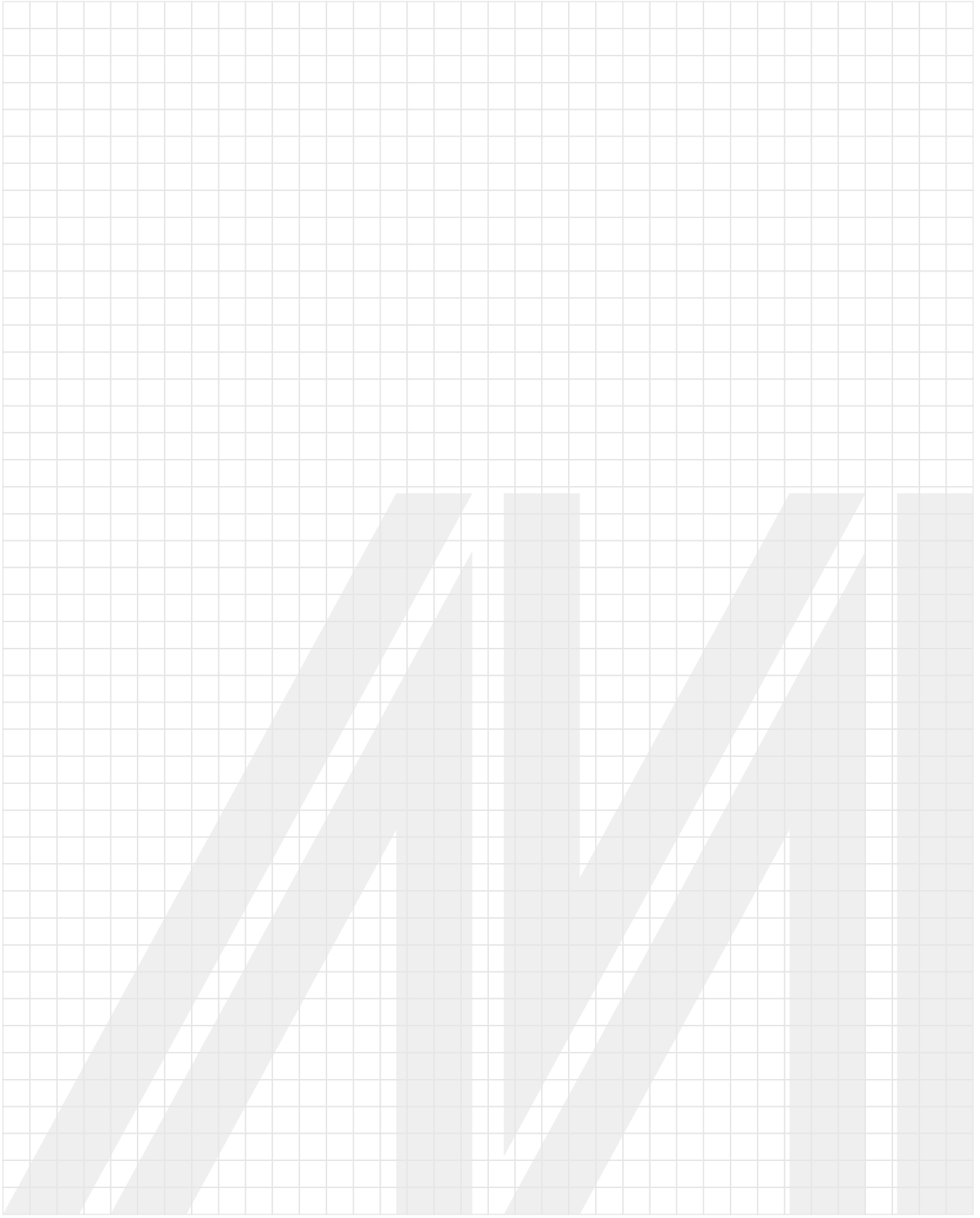

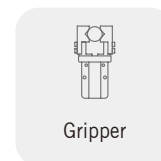
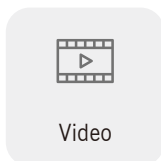
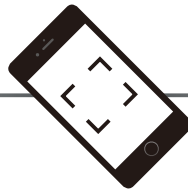

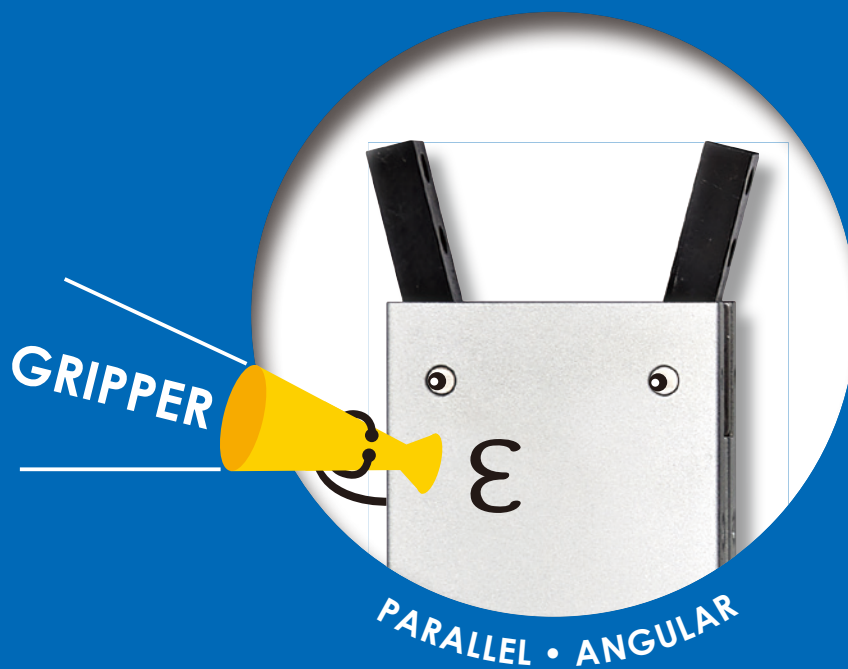

**MINDMAN INDUSTRIAL CO., LTD. | OVERSEAS DEPARTMENT**

- ▶ No.106, Sec. 3, Chengde Rd., Datong District, Taipei City 103, Taiwan  
✉ [mindman@mindman.com.tw](mailto:mindman@mindman.com.tw)    🌐 [www.mindman.com.tw](http://www.mindman.com.tw)  
☎ 886-2-25914100    📠 886-2-25957633 886-2-25975522
- ▶ The specifications are subject to change without advance notice.  
CAT. NO: MD-DM2105-E

 **mindman**