

MACT410 series Stainless steel #316 type

AIR UNITS (F.R.L.UNIT)

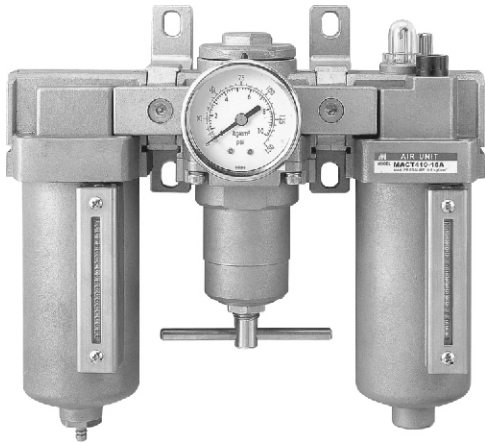

Symbol

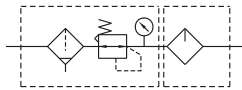

Specification

Model	MACT410		
Components	MAF410, MAR410, MAL410		
Bore No.	10A	15A	20A
Port size	3/8	1/2	3/4
Medium	Air		
Operating pressure range	0.05~1 MPa		
Proof pressure	1.5 MPa		
Regulated pressure range	0.05~0.85 MPa		
Ambient temperature	-5~+60°C (No freezing)		
Filter element	Standard: 40 μm Option: 5,20 μm		
Lubricating oil capacity	130c.c		
Min. flow for oil drip	50 ℓ/min		
Recommended lubricating oil	Turbine oil ISO-VG32		
Attachment	Pressure gauge, bracket		
Weight	5968 g		

Order example

MACT410 - 15A - D - □ - □

MODEL

BORE SIZE
10A: 3/8
15A: 1/2
20A: 3/4

D: auto drain valve

FILTER ELEMENT
Blank: 40 μm
5u: 5 μm
20u: 20 μm

PORT THREAD
Blank: Rc thread
G: G thread
NPT: NPT thread

※ Standard unit contains semi-auto-drain function when operating pressure below 0.05 MPa.

Flow feature

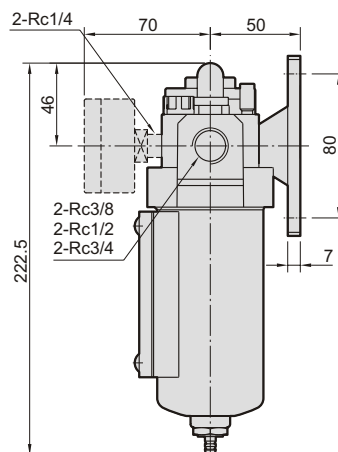
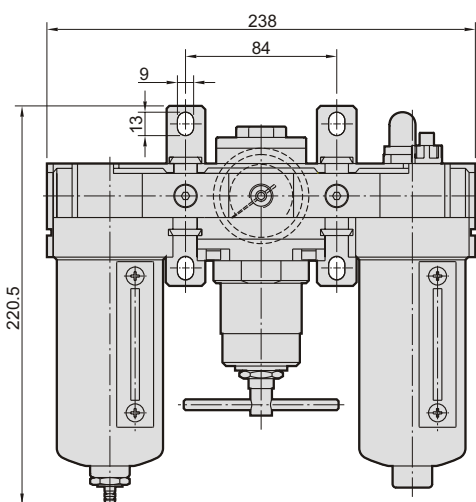
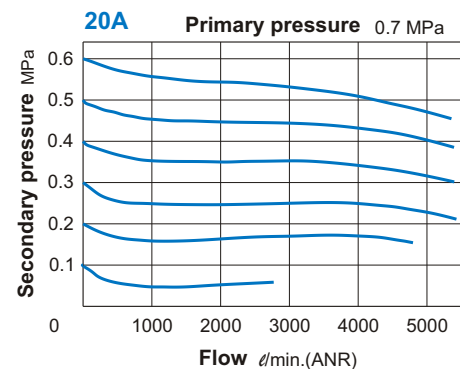
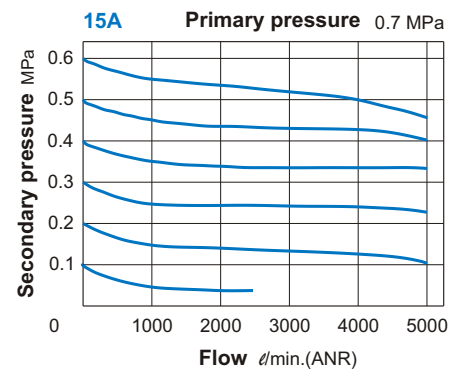

Mindman