

## SERVICE MANUAL

### Electro-Pneumatic Regulator

**RS-485**

### MAER210/310 series

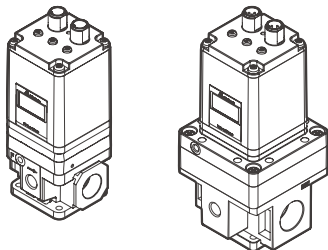

#### Order example

**MAER210 – 8A – 9K – 101 – B1 S3 CS – □**

①

②

③

④

⑤

⑥

⑦

⑧

- |            |                 |                    |                      |                           |
|------------|-----------------|--------------------|----------------------|---------------------------|
| ① Model    | ② Port size     | ③ Pressure range   | ⑤ Bracket            | ⑥ Power cable             |
| <b>210</b> | <b>8A:</b> 1/4  | <b>1K:</b> 0.1 MPa | Blank: Without       | Blank: Without            |
| <b>310</b> | <b>10A:</b> 3/8 | <b>5K:</b> 0.5 MPa | <b>B1:</b> L type    | <b>S3:</b> Straight 3m    |
|            | <b>15A:</b> 1/2 | <b>9K:</b> 0.9 MPa | <b>B2:</b> Flat type | <b>L3:</b> Right angle 3m |

④ Communication model	Pressur display unit
<b>10:</b> RS-232	<b>1:</b> MPa
<b>20:</b> RS-485	<b>2:</b> kgf/cm <sup>2</sup>
	<b>3:</b> bar
	<b>4:</b> psi
	<b>5:</b> kPa

- |                           |                        |
|---------------------------|------------------------|
| ⑦ Commun. Cable           | ⑧ Port thread          |
| Blank: Without            | Blank: Rc thread       |
| <b>CS:</b> Straight 3m    | <b>G:</b> G thread     |
| <b>CL:</b> Right angle 3m | <b>NPT:</b> NPT thread |

## Precaution

To ensure safe operation, please read this service manual carefully before use. When designing and manufacturing equipment using Mindman products, the manufacturer is obligated to ensure that the safety of the mechanism, pneumatic control circuit and/or air control circuit and the system that runs the electrical controls are secured.

### Explanation of label

Observe the warnings and cautions on the following pages to prevent accidents. These instructions indicate the level of potential hazard by labels of "**WARNING**" or "**CAUTION**". Note that some items indicated with "**CAUTION**" may lead to serious results depending on the conditions. All items contain important information and must be observed.



### WARNING

A dangerous situation may occur if handling is mistaken, leading to fatal or serious injuries.

---

- ① Let the designer of pneumatic system or rule tester to determine if this direction control valve is suitable or not.
- ② The product must be operated by the person who has professional knowledge and practical experience.
- ③ Please confirm product specifications before use. Do not use input signal exceeding specifications. This product could malfunction fire if input signal exceeding the working range is applied.
- ④ If an abnormality occurs during operation, immediately turn off the power and air pressure and stop using it.
- ⑤ This product is adjusted for each specification at the time of shipment from the factory. Disassemble and reformation are prohibited, as this way might lead to malfunction.



### CAUTION

A dangerous situation may occur if handling is mistaken, leading to minor injuries or property damage.

---

- ① Avoid using this regulator where it will be subject to direct sunlight, water or oil, etc.
- ② Use in place where the temperature changes drastically or at high humidity may cause damage due to dew condensation in the product.
- ③ If supply pressure to this product is interrupted while the power is still on, the inner solenoid valve will continue to operate and a humming noise may be generated. Since the life of the product may be shortened, shut off the power supply also when supply pressure is shut off.
- ④ If electric power is shut off while pressure is being applied, the output pressure will be retained. However, this output pressure is held only temporarily and is guaranteed.

## Precaution

- ⑤ The product characteristics are confined to no flow in the pipeline. When air is consumed on the output side, pressure may become unstable.
- ⑥ In order to avoid the error caused by noise, please take the following measures:
  - a Set the line filter on AC power line to remove the power noise.
  - b Keep the product away from the engine and power line to avoid noise affects.
  - c Induced charge (like solenoid valve, relay), must prevent them from negative charge.
  - d In order to avoid the effects of power fluctuation, please cut off the power before plug the connector
- ⑦ The cable plug is four-core wire. Please avoid contact with other wires to avoid product failure.
- ⑧ Please note that the right angled cable connector does not rotate and is limited to only one entry direction.
- ⑨ Use clean compressed air that does not contain corrosive gas. Poor air quality adversely affects function and life.
- ⑩ Do not use a lubricator on the supply side of this product, the lubricated air might cause malfunction. When lubrication of terminal equipment is necessary, connect a lubricator on the output side of the equipment and set a check valve.
- ⑪ When supplying compressed air for the first time after connecting pipes, confirm that no air is leaking from any pipe connections.
- ⑫ Tighten pipes with the appropriate torque to prevent air leakage and screw damage. First tighten the screw by hand to prevent damage to screw threads, then use a tool.
- ⑬ For the pneumatic source, use cleaned air from which the solid, water and oil contents were eliminated sufficiently, using an air dryer, filter and oil mist filter. Recommend selecting a filtration precision of  $5\mu\text{m}$  or less.

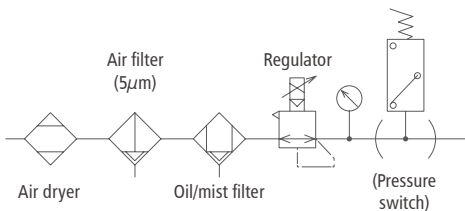

## Installation instructions

- ① The 4-Pin port on the right side is the power supply port. Please refer to page 5 for details on the wiring method.
- ② The 5-Pin port on the left side is the communication interface. Please refer to page 5 for details on the wiring method.
- ③ Be aware that excessive bending may cause damage or short circuit, resulting in abnormal function or fire. Be sure to reserve sufficient space for wiring. (The minimum bending radius of the wire is 70mm)
- ④ When installing L-type bracket and right-angle cables together with the product, pay attention to whether the wiring space is sufficient.
- ⑤ Please note that the right-angle cable connector does not rotate and is limited to only one entry direction.
- ⑥ Insert/pull out the connector after cutting the power supply.

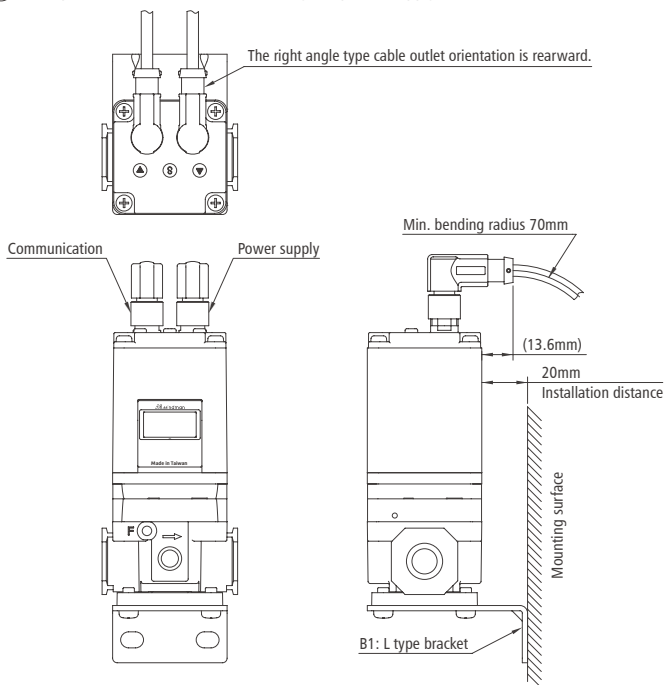

## Wiring method

### WARNING

- ① Please confirm the product specification and read wiring method carefully before wiring.
- ② The color of connector pins and cable conductors must be checked when wiring. Check wire color with handling precaution, since improper wire connection leads to destruction/-failure and malfunction.
- ③ Do not use power voltage exceeding specifications. The product could malfunction or catch fire if voltage exceeding the working range is applied.
- ④ Short-circuiting the load could result in rupture or fire.
- ⑤ The connection between the cable plug and the wire is weak. Excessive bending may shorten the life of the plug set, causing breakage or damage.

#### ► Pin assign of product connector port in RS-485 model

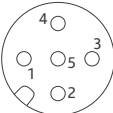
Port	Pin assign	Wire color (*2)	
Power supply port (*1)		1. Power Supply	Brown
		2. No Connect	White
		3. GND	Blue
		4. No connect	Black
Communicate connect port		1. No connect	Yellow
		2. B(-)	Brown
		3. A(+)	White
		4. GND	Green
		5. No connect	Gray

\*1. The pin-2 and pin-4 of power supply port must be prevent to connect any signal to avoid interference or malfunction.

\*2. Wire color is when the option cable is used.

\*3. Please pay attention to shielding the unused pins to avoid malfunction or abnormal function caused by noise.

#### ► Connection of external equipment to RS-485 model

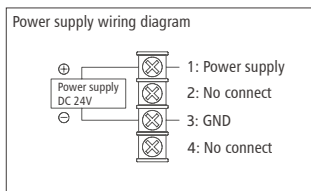
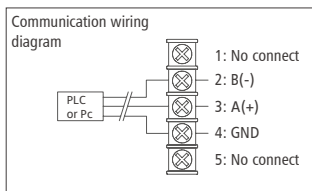

## Communication specification

Item	Specification	
Protocol	RS-485	
Address	1	(Default)
Baud rate	19,200 bps	(Default)
Transmission format setting	8,N,1	(Default)
Start bit	1 bit	
Data length	8 bit	
Stop bit	1 bit	
Parity bit	N/A	
Flow control	N/A	
Character-code	RTU	

## COMMUNICATION PROTOCOL

Read / Write Code	Description
0x03	Read parameter setting value
0x06	Write parameter setting data

# COMMUNICATION PROTOCOL

## Note.

- ① The character-code used to communicate is MODBUS RTU.
- ② If the command is not answered correctly, please confirm whether the content exceeds the allowable range or undefined, or check whether the communication settings are correct.

Function code	Item	Explanation	Operation
0000	4.02	1. Read current pressure. 2. Display value set to zero (data must be 0x00)	Read Write
0001	4.00	Set target pressure	Read Write
0002		Decimal point position 0: nn.n 1: n.nn 2: .nnn	Read
0003	Unt	Pressure Unit 1: PSI 2: BAR 3: MPa 4: kgf/cm <sup>2</sup> 5: kPa	Read Write
0004	Gn	Valve Gain coefficient Change the gain value to increase or decrease the pressure regulation speed. Range: 1~26 (Default: 5)	Read Write
0005	Sb	Sensitivity Set pressure allowable fluctuation range Range: 1~16	Read Write
0006	F_1	Set the min. value of the set pressure range. Range: $0 \leq F1 < F2$	Read Write
0007	F_2	Set the max. value of the set pressure range. Range: $F1 < F2 \leq 10.00$ (kgf/cm <sup>2</sup> )(Note)	Read Write
0008	Adr	Address number Range: 0~248 (Default: 1)	Read Write
0009	Bud	Baud rate setting 1: 9,600 2: 19,200 (Default) 3: 38,400	Read Write

Note: For 9K specification range, 1K:  $F1 < F2 \leq 1.10$  (kgf/cm<sup>2</sup>), 5K:  $F1 < F2 \leq 5.50$  (kgf/cm<sup>2</sup>).

# COMMUNICATION PROTOCOL

Function code	Item	Explanation	Operation
000A	<i>PAR</i>	Transmission format setting 1: 8.N.1 (Default) 2: 8.O.1 3: 8.E.1 4: 8.N.2	Read Write
000B	<i>uP</i>	Air supply solenoid valve basic duty value Range: 1~255 (unit: 0.1 ms)	Read Write
000C	<i>dn</i>	Exhaust solenoid valve basic duty value Range: 1~255 (unit: 0.1 ms)	Read Write
000D	<i>SuP</i>	Air supply solenoid valve additional duty value Range: 1~255 (unit: 0.1 ms)	Read Write
000E	<i>Sdn</i>	Exhaust solenoid valve additional duty value Range: 1~255 (unit: 0.1 ms)	Read Write
000F	<i>Frq</i>	Frequency setting Set solenoid valve operating frequency Range: 1~255 (Default: 40) (unit: 1Hz)	Read Write
0010	<i>AuP</i>	Brake coefficient (*Self-modification is not recommended) Range: 1~255 Default: According to factory inspection	Read Write
0011	<i>Adn</i>	Brake coefficient (*Self-modification is not recommended) Range: 1~255 Default: According to factory inspection	Read Write
0012	<i>du</i>	Difference gain coefficient (*Self-modification is not recommended) Range: 4, 8, 16, 32, 64, 128, 256 Default: 32	Read Write

## Supplement:

The default values of function codes 0010, 0011, and 0012 are based on product test results. It is not recommended for customers to adjust by themselves.



# Manual setting method

## Unlock keys:

Press  $\nabla$  for more than 2 seconds to display Loc, and then press  $\textcircled{S}$  to unlock keys.

## Lock keys:

Press  $\triangle$  for more than 2 seconds to display unL, and then press  $\textcircled{S}$  to lock keys.

## Flow chart

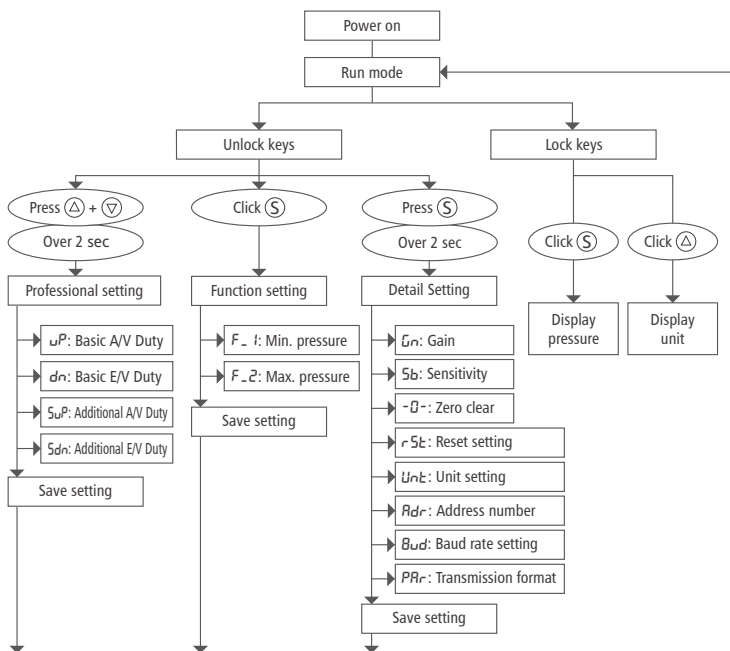

A/V: Air supply solenoid valve ; E/V: Exhaust solenoid valve.

## Display character and function comparison table

Valve Gain Coefficient (GN)	<i>Gn</i>	Min. value of the set pressure range	<i>F_1</i>	Air supply solenoid valve basic duty	<i>uP</i>
Sensitivity (SB)	<i>Sb</i>	Max. value of the set pressure range	<i>F_2</i>	Exhaust solenoid valve basic duty value	<i>dn</i>
Zero Function (ZERO)	<i>-0-</i>	Switch output point 1	<i>P_1</i>	Air supply solenoid valve additional duty value	<i>SuP</i>
Reset setting (RESET)	<i>rSt</i>	Switch output point 2	<i>P_2</i>	Exhaust solenoid valve additional duty value	<i>Sdn</i>
Unit setting	<i>Unit</i>	Switch output	<i>tr,</i>	Save setting	<i>SAU</i>
Address number	<i>Adr</i>	Hysteresis mode	<i>HYS</i>		
Baud rate setting	<i>Bud</i>	Window comparator mode	<i>Y, n</i>		
Trans. Format	<i>PAR</i>				

Pressure display unit					
MPa	<i>mPA</i>	kgf/cm <sup>2</sup>	<i>kgf</i>	bar	<i>bAR</i>
psi	<i>PS,</i>	kPa	<i>kPA</i>		

## Actual situation and parameter application

According to different use conditions and occasions, the parameters of the air supply and exhaust valves can be adjusted to ensure that the product meets the needs of us.

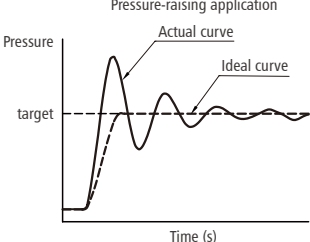
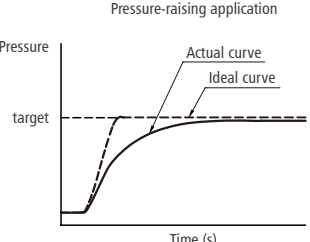
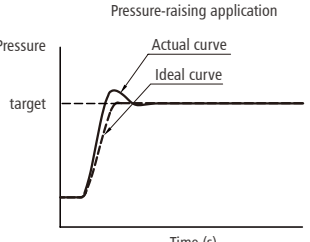
<p>Pressure-raising application</p>  <p>The graph plots Pressure on the y-axis and Time (s) on the x-axis. A horizontal dashed line represents the 'target' value. A solid line labeled 'Actual curve' starts at a low pressure, rises sharply to overshoot the target, then oscillates around the target value with decreasing amplitude. A dashed line labeled 'Ideal curve' starts at the same low pressure and rises smoothly to reach the target value.</p>	<p>Description: The secondary pressure still fluctuates violently after a period of time and cannot be stabilized at the target value.</p> <p>Possible reasons: Gn or up/dn value set too large.</p> <p>Solutions: Appropriately decrease the up and dn value.</p>
<p>Pressure-raising application</p>  <p>The graph plots Pressure on the y-axis and Time (s) on the x-axis. A horizontal dashed line represents the 'target' value. A solid line labeled 'Actual curve' starts at a low pressure and rises slowly, asymptotically approaching the target value but not reaching it. A dashed line labeled 'Ideal curve' starts at the same low pressure and rises more steeply to reach the target value.</p>	<p>Description: The secondary pressure rises slowly and cannot reach the target value.</p> <p>Possible reasons: Supply pressure is insufficient. Up value set too small.</p> <p>Solutions: Check the supply pressure. Appropriately increase the up or Sup value.</p>
<p>Pressure-raising application</p>  <p>The graph plots Pressure on the y-axis and Time (s) on the x-axis. A horizontal solid line represents the 'target' value. A solid line labeled 'Actual curve' starts at a low pressure, rises to overshoot the target significantly, and then slowly decays back to the target value. A dashed line labeled 'Ideal curve' starts at the same low pressure and rises smoothly to reach the target value.</p>	<p>Description: The pressure overshoot is large, and it takes a while to stabilize to the set value.</p> <p>Possible reasons: Gn or up value set too large.</p> <p>Solutions: Fine-tune the Sdn value to increase the initial exhaust speed, or fine-tune the up value to decrease the pressure rise speed.</p>

## Actual situation and parameter application

According to different use conditions and occasions, the parameters of the air supply and exhaust valves can be adjusted to ensure that the product meets the needs of us.

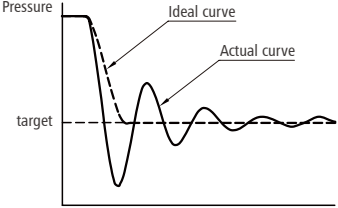
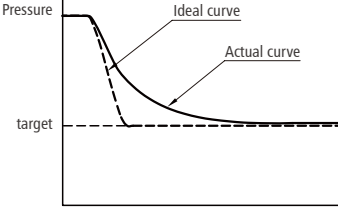
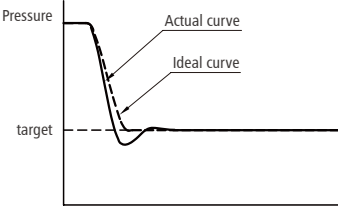
<p>Pressure-raising application</p>  <p>Pressure</p> <p>target</p> <p>Time (s)</p> <p>Ideal curve</p> <p>Actual curve</p>	<p>Description: The secondary pressure still fluctuates violently after a period of time and cannot be stabilized at the target value.</p> <p>Possible reasons: Gn or up/dn value set too large.</p> <p>Solutions: Appropriately decrease the up and dn value.</p>
<p>Pressure-raising application</p>  <p>Pressure</p> <p>target</p> <p>Time (s)</p> <p>Ideal curve</p> <p>Actual curve</p>	<p>Description: The secondary pressure drops slowly and cannot reach the target value.</p> <p>Possible reasons: Supply pressure is insufficient. Up value set too small.</p> <p>Solutions: Appropriately increase the dn or Sdn value.</p>
<p>Pressure-raising application</p>  <p>Pressure</p> <p>target</p> <p>Time (s)</p> <p>Actual curve</p> <p>Ideal curve</p>	<p>Description: The pressure overshoot is large, and it takes a while to stabilize to the set value.</p> <p>Possible reasons: dn or Sdn value set too large.</p> <p>Solutions: Appropriately decrease the dn or Sdn value.</p>

## Example

Pressure setting can be done by sending input data to the electro-pneumatic regulator from the master PLC.

Ex1. Target pressure is 3.00 kgf/cm<sup>2</sup>.

Step1. Set the pressure unit.

(REQUEST)				
Slave Address	Write	Function Code	Data	CRC CheckSum
0x01	0x06	0x00 0x03	0x00 0x04	0x78 0x09



(RESPONSE)				
Slave Address	Write	Function Code	Data	CRC CheckSum
0x01	0x06	0x00 0x03	0x00 0x04	0x78 0x09

Step2. Set the target pressure.

(REQUEST)				
Slave Address	Write	Function Code	Data	CRC CheckSum
0x01	0x06	0x00 0x01	0x01 0x2C	0xD8 0x47



(RESPONSE)				
Slave Address	Write	Function Code	Data	CRC CheckSum
0x01	0x06	0x00 0x01	0x01 0x2C	0xD8 0x47

Ex2. Inquire the sensitivity value.

(REQUEST)				
Slave Address	Read	Function Code	Data	CRC CheckSum
0x01	0x03	0x00 0x05	0x00 0x01	0x94 0x0B



(RESPONSE)				
Slave Address	Read	Data Number	Data	CRC CheckSum
0x01	0x03	0x02	0x00 0x06	0x38 0x46