

AIR UNIT (PRECISION REGULATOR)

Air Supply

⚠️ Caution

- 1 If the air supply line contains drain or particulate, etc., the primary pressure fixed throttle can become clogged leading to malfunction, and therefore, be sure to use an air filter (MAF or MAM*) & mist separator.
- 2 Never use a lubricator on the primary side of the regulator, as this will positively cause the fixed throttle to become clogged and result in a malfunction. If lubrication is required for terminal devices, connect a lubricator on the secondary side.

Maintenance

⚠️ Warning

- 1 When to be during maintenance, first reduce the precision regulator set pressure to zero, and completely shut off the supply pressure.
- 2 When a pressure gauge is to be mounted, remove the plug after reducing the regulator pressure set pressure to zero. (Step a→b→c)

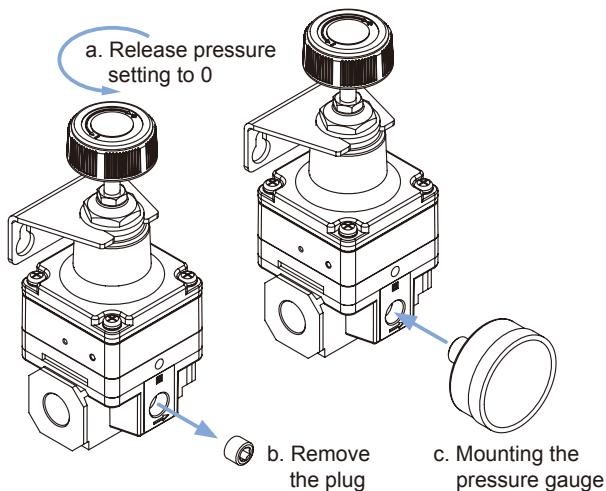

MAIR300 Product Precautions

⚠️ Caution

- 1 The primary pressure is relatively high (approx. 0.5 MPa or more), the set pressure is low (approx. 0.1 MPa or less), and when operated with the secondary side released to the atmosphere, there may be pulsations in the setting pressure. In this kind of situation, operate with the primary pressure reduced as much as possible, or increase the set pressure somewhat and restrict the secondary side line (add and adjust a stop valve, etc.)
- 2 When used for the purpose of a relief function, and capacity of the precision regulator is large, the exhaust sound will be loud when being relieved. the operation with a silencer (MSR*) mounted on the exhaust port (EXH port). (Silencer refer to Other Auxiliary Equipment)

Operation

⚠️ Caution

- 1 Do not use a precision regulator outside the range of its specifications as this can cause failure. (Refer to specifications.)
- 2 When mounting is performed, make connections while confirming port direction (indications).
- 3 Screw a panel nut with the proper torque when mounting onto a panel. (be listed as follows)

Model	MAIR100	MAIR200	MAIR300
Torque (kgf)	12.5	21	21

Looseness or faulty sealing will occur if tightening torque is insufficient, while thread damage will result if the torque is excessive.

⚠️ Warning

- 4 If a directional switching valve (solenoid valve, mechanical valve, etc.) is mounted on the primary side of the the precision regulator and repeatedly switched ON and OFF, wear of the nozzle/diaphragm section will be accelerated and a discrepancy in the setting value may occur. Therefore, avoid using a directional switching valve on the primary side. In the event a directional switching valve will be used, install it on the secondary side of the precision regulator.
- 5 Air is normally released from the bleed hole (the hole on the side of the body's mid-section). This is a necessary consumption of air based on the construction of the precision regulator, and is not an abnormality.
- 6 In order to avoid operation mistakes, make sure to tighten the lock nut after pressure adjustment.

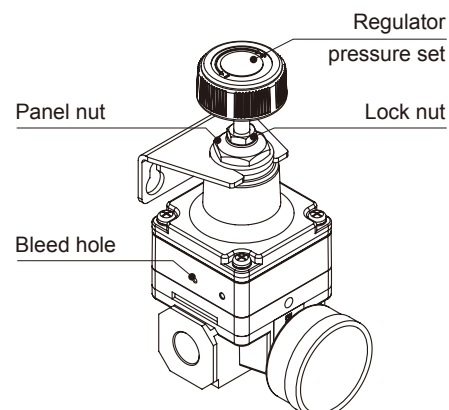

MAIR300 series

AIR UNIT (PRECISION REGULATOR)



mindman



Symbol

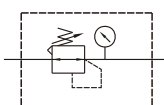

Specification

Model	MAIR300		
Bore No.	8A	10A	15A
Port size	1/4	3/8	1/2
Medium	Air		
Max. operating pressure	1 MPa		
Min. operating pressure	Setting pressure +0.1 MPa		
Proof pressure	1.5 MPa		
Regulated pressure range	2K: 0.005~0.2 MPa		
	4K: 0.01~0.4 MPa		
	8K: 0.01~0.8 MPa		
Sensitivity	0.2% F.S.		
Repeatability	±0.5% F.S.		
Air consumption(*)	11.5 ℓ/min(ANR) F.S.		
Ambient temperature	- 5~+60°C (No freezing)		
Attachment	Bracket		
Option	Pressure gauge (PG-40S)		
Weight	875 g		

Order example

MAIR300 — 8A — 2K — C — □

MODEL

PORT SIZE

8A: 1/4
10A: 3/8
15A: 1/2

ADJUSTABLE PRESS. RANGE

2K: 0.005~0.2 MPa
4K: 0.01~0.4 MPa
8K: 0.01~0.8 MPa

PORT THREAD

Blank: Rc thread
G: G thread
NPT: NPT thread

Blank: Without pressure gauge
C: Pressure gauge (PG-40S)

* For supply pressure 1 MPa.

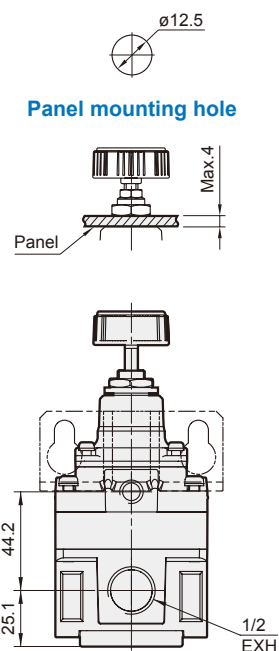
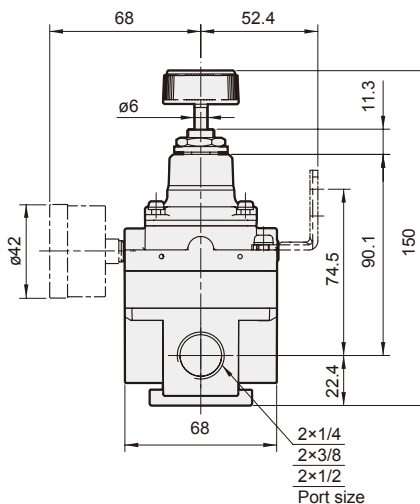
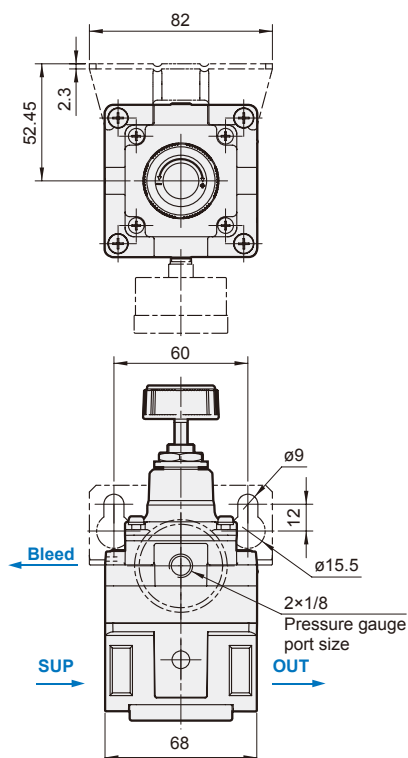

Flow feature

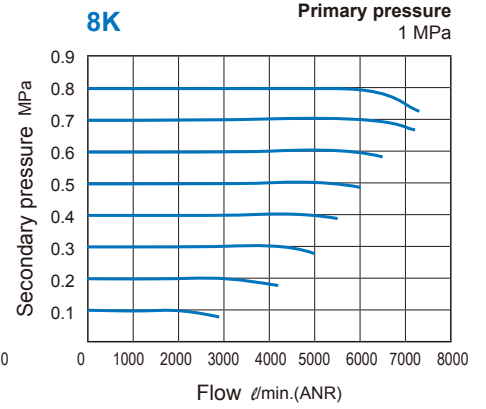
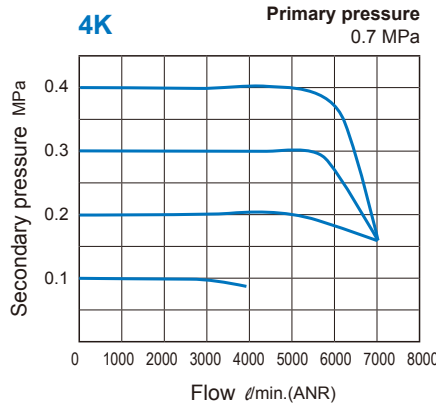
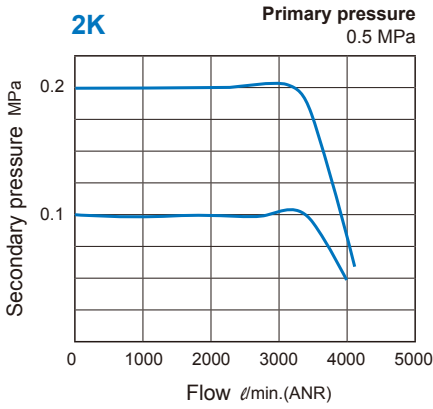

Relief characteristics

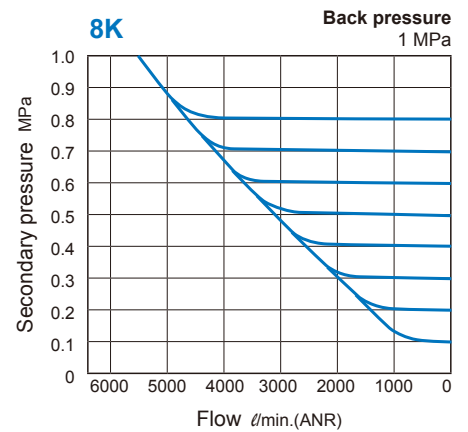
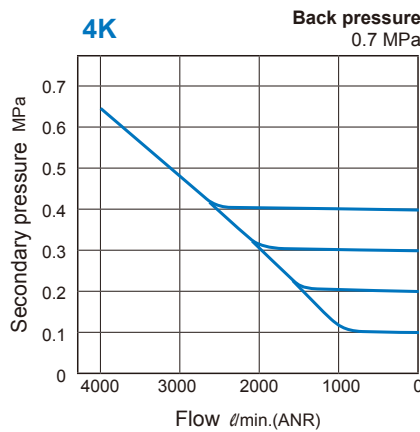
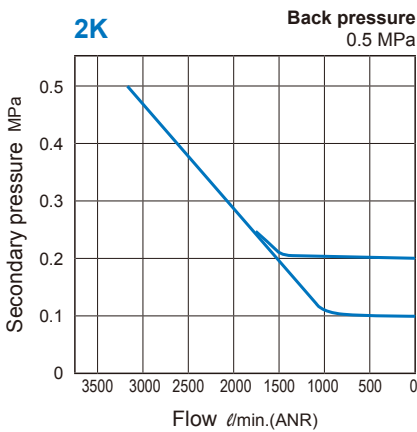

Pressure characteristics

