

Airline Regulator

HAND-HELD REGULATOR

- ▶ Hand-held regulator 1.5 MPa
- ▶ Two standard inlet pressures



Pneumatic Equipment



MAR300LK

Hand-held regulator could be directly assembled with pneumatic tools. According to the user's applications, you can regulate the pressure of pneumatic tool.

- The pressure regulation during painting.
- The pressure regulation for nail gun.
- Torque management for operating air.

◆ Order example

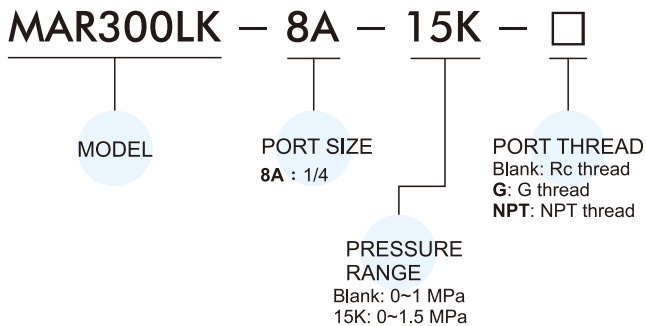

◆ Features

1. Compact

Design: No convex shaft, small size and high transportability. Anodized aluminum body to achieve lightweight. (80g around)

2. Not need for pressure gauge

The outlet pressure can be observed through the scale of adjustment knob to determine. The lock mechanism can prevent rotation by accidentally.

3. Quick and Flexibility to regulate pressure

The unique structure of adjustment knob enables the pressure regulation to be completed within one turning round.

4. Outlet pressure can be relieved easily

Outlet pressure can be directly exhausted by turning back the adjustment knob.

- Under 1.0 MPa
General Industrial plant
- Under 1.5MPa
Automobile maintenance plant

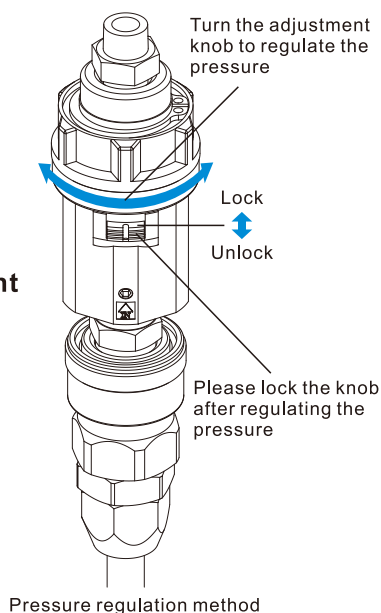

◆ Inside structure & Parts list

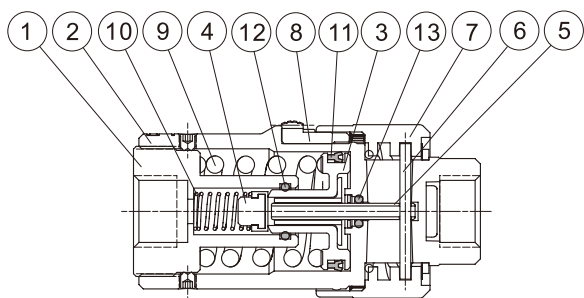

No.	Part name	Material
1	Body #1	Aluminum alloy
2	Body #2	Aluminum alloy
3	Piston	POM
4	Valve	NBR / Copper
5	Adjustment shaft	Copper
6	Pin	Medium carbon steel
7	Handle	POM
8	Handle lock	POM
9	Adjustment spring	SWP
10	Valve spring	Stainless steel
11	Piston packing	NBR
12	O ring	NBR
13	O ring	NBR

◆ Specification

Model	MAR300LK
Bore No.	8A
Port size	1/4
Medium	Air
Operating pressure range	0~1.0 MPa 15K: 0~1.5 MPa
Proof pressure	3.75 MPa
Set pressure range	0.3~0.9 MPa
Ambient temperature	0~+60°C (No freezing)
Weight	80 g

◆ Flow feature

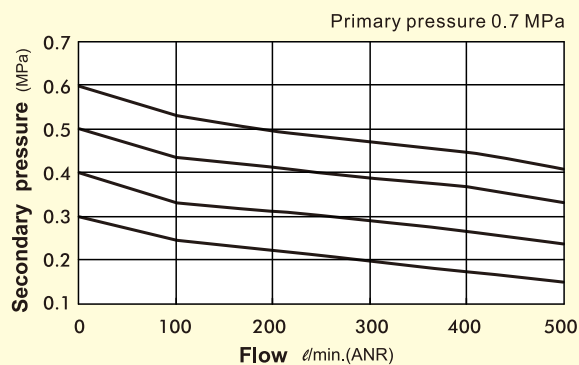

◆ Dimension

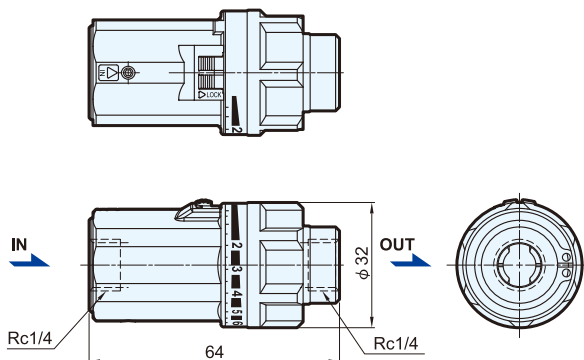

◆ Pressure feature

※ Variation reference between primary & secondary pressure.

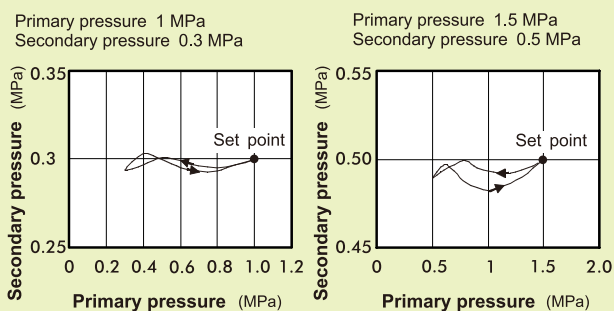

MINDMAN INDUSTRIAL CO., LTD.

<http://www.mindman.com.tw> E-mail: mindman@mindman.com.tw

▶ OVERSEAS DEPARTMENT

No.106, Sec. 3, Chengde Rd., Datong District, Taipei City 103, Taiwan
 TEL: 886-2-25914100
 FAX: 886-2-25957633 • 886-2-25975522

▶ OFFICE

No.106, Sec. 3, Chengde Rd., Datong District, Taipei City 103, Taiwan
 TEL: 886-2-25913001 • 886-2-25976201
 FAX: 886-2-25912822 • 886-2-25981879