



Push type



Applications



Technical data



Caution for safety  
(Read before installing)



### Order example

**MCGA — 03 — 20 — 50 — G**

MODEL

TUBE I.D.

STROKE

PORT THREAD

Blank: Rc thread  
G: G thread  
NPT: NPT thread

#### PURPOSE / TYPE OF BEARING





Code	Purpose / Type of bearing
03	Stop / Slide bush
13	Lift / Linear bearing (*)
53	Lift / Slide bush

\* The type is not available as a stopper.

### Features

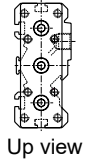
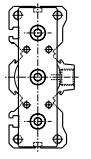
- Strong cylinder capable of high loads, used extensively for stopping work carriers in both the vertical and horizontal position.
- Large diameter guide rods enable cylinder to take high off-set loads.
- Can be used as 90 degree pusher on large conveyor systems.
- Magnetic as standard.

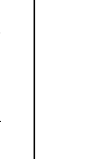
### Specification

Model	MCGA			
Model (Stop type view)				
Acting type	Double acting			
Tube I.D.	20	32,40	50,63	80
Port size	Rc1/8		Rc1/4	Rc3/8
Medium	Air			
Operating pressure range	0.1~1 MPa			
Proof pressure	1.5 MPa			
Lubrication	Not required			
Cushion	With rubber cushion pad			
Ambient temperature	-5~+60°C (No freezing)			
Available speed range	50~500 mm/sec			
Sensor switch	RCB 			

### Table for standard stroke

Series variety (Bearing type)	Tube I.D.	Stroke (mm)			
		30	50	75	100
<b>MCGA-03</b> (Slide bush)	ø20				
	ø32				
	ø40				
	ø50				
	ø63				
	ø80				
<b>MCGA-13</b> (Linear bearing)	ø20				
	ø32				
	ø40				
	ø50				
	ø63				
	ø80				
<b>MCGA-53</b> (Slide bush)	ø20				
	ø32				
	ø40				
	ø50				
	ø63				
	ø80				

- The other stroke lengths that fall in the range between our standard strokes will be manufacture by the next large standard stroke with additional spacer.  
ex: The 40mm stroke length will be made by 50mm stroke with additional spacer.
- Please contact us if the stroke is out of specification.

### Capacity graph

Capacity for the use as a stopper

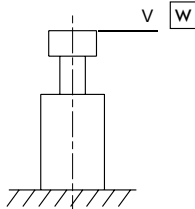

#### Caution

Linear bearing type is not available as a stopper.

### Stop capacity

MCGA-03... $\phi 20, \phi 32-30st$

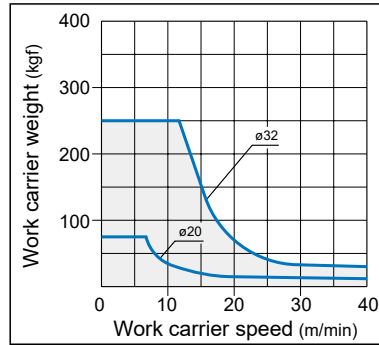

### Stop capacity

MCGA-03... $\phi 40, \phi 50, \phi 63, \phi 80-50st$

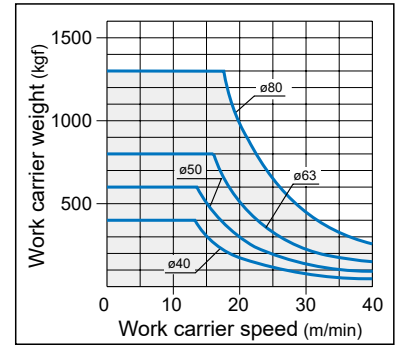

### Normal lateral load

MCGA-03... $\phi 20, \phi 32-30st$

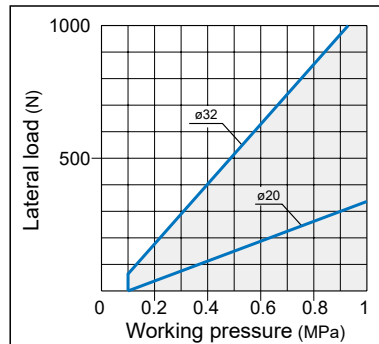

### Normal lateral load

MCGA-03... $\phi 40, \phi 50, \phi 63, \phi 80-50st$

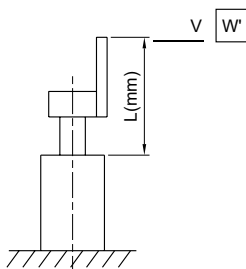
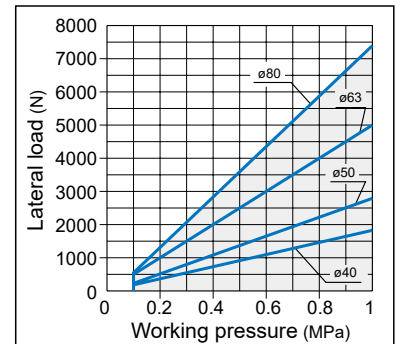

$$W = W' \times \frac{L}{\ell}$$

### Coefficients for conversion

MCGA series	$\phi 20$	$\phi 32$	$\phi 40$	$\phi 50$	$\phi 63$	$\phi 80$
$\ell$	48	55	80	85	90	98

$W$ : The maximum weight of the work carrier in the above graph for the stopper's.

For the use of attaching a plate to the link bar, choose a bore size referring to the right formula.

### Capacity graph

#### Capacity for the use as a lifter

Allowable eccentric load for the use as a lifter (at supply pressure 0.5MPa)

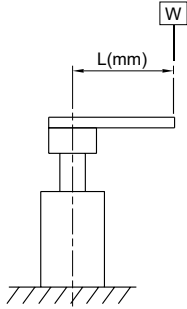

Show the dynamic allowable value at L(mm) eccentricity from the center of the guide rod.

### Linear bearing

MCGA-13... $\phi 20, \phi 32\text{-}30\sim 100\text{st}$

MCGA-13... $\phi 40, \phi 50, \phi 63, \phi 80\text{-}50\sim 100\text{st}$

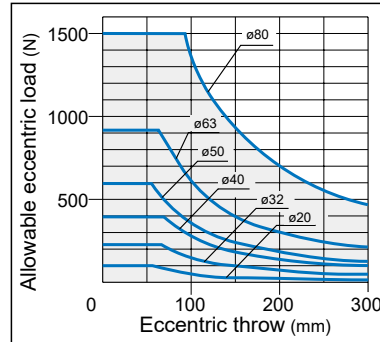

### Slide bush

MCGA-53... $\phi 20, \phi 32\text{-}30\text{st}$

MCGA-53... $\phi 40, \phi 50, \phi 63, \phi 80\text{-}50\text{st}$

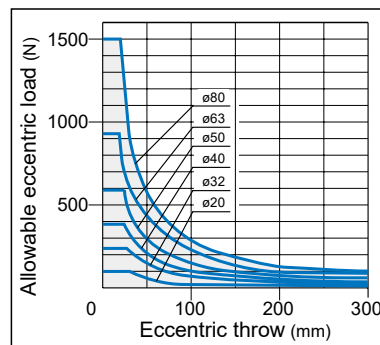

### Slide bush

MCGA-53... $\phi 20, \phi 32\text{-}50\sim 100\text{st}$

MCGA-53... $\phi 40, \phi 50, \phi 63, \phi 80\text{-}75\sim 100\text{st}$

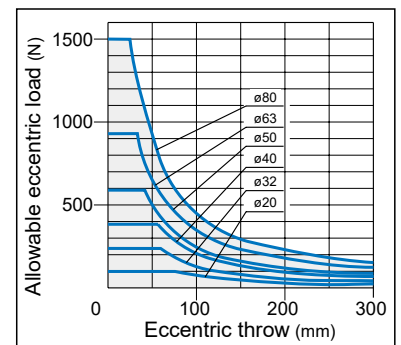

### ■ Installation of sensor switch (For Stop / Lift / Push type)

#### Sensor switch: RCB

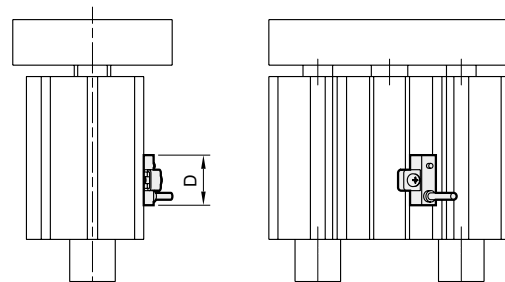
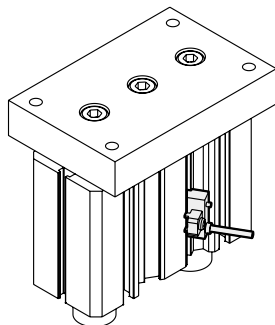

Code Tube I.D.	A	B	C	D
20	39.5	24.5	7.5	22
32	59.5	30.5	8	22
40	64	31	5	22
50	71.5	33.5	2.5	22
63	88.5	40.5	1.5	22
80	103	43	0	22

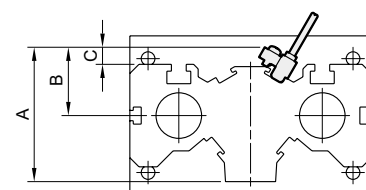

Unit: N

### Capacity table

#### Allowable lateral load

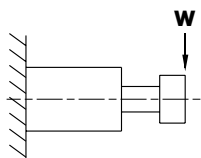

Shows the dynamic allowable value, when actuating the cylinder with lateral load  $W$  at the guide rods' top (vertical load against the guide rods).

Tube I.D.	Bearing type	Stroke (mm)			
		30	50	75	100
$\varnothing 20$	Slide bush	58.84	88.26	73.55	58.84
	Linear bearing	78.45	63.74	49.03	39.23
$\varnothing 32$	Slide bush	117.7	147.1	117.7	98.07
	Linear bearing	156.9	127.5	98.07	78.45
$\varnothing 40$	Slide bush	—	147.1	166.7	137.3
	Linear bearing	—	225.6	186.3	156.9
$\varnothing 50$	Slide bush	—	147.1	176.5	147.1
	Linear bearing	—	245.2	196.1	166.7
$\varnothing 63$	Slide bush	—	215.7	274.6	215.7
	Linear bearing	—	—	323.6	284.4
$\varnothing 80$	Slide bush	—	245.2	294.2	245.2
	Linear bearing	—	—	588.4	539.4

Unit: N.m

#### Allowable rotating torque

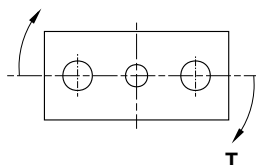

Shows the dynamic allowable value, when actuating the cylinder with a rotating torque  $T$  at the guide rods' top.

Tube I.D.	Bearing type	Stroke (mm)			
		30	50	75	100
$\varnothing 20$	Slide bush	0.686	0.981	0.785	0.686
	Linear bearing	0.883	0.686	0.539	0.441
$\varnothing 32$	Slide bush	2.059	2.55	2.059	1.765
	Linear bearing	4.609	2.157	1.765	1.471
$\varnothing 40$	Slide bush	—	3.628	3.727	3.236
	Linear bearing	—	4.609	3.825	3.236
$\varnothing 50$	Slide bush	—	4.315	5.099	4.511
	Linear bearing	—	6.865	5.786	4.903
$\varnothing 63$	Slide bush	—	6.276	8.041	6.276
	Linear bearing	—	—	9.512	8.336
$\varnothing 80$	Slide bush	—	10.79	13.73	12.75
	Linear bearing	—	—	27.46	24.52

#### Anti-roll accuracy

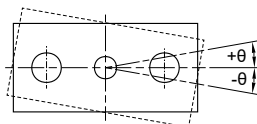

- The values are the deflection angle against the piston rod.
- Exclusive factor of the guide rods' deflection.

Tube I.D.	Bearing type	Anti-roll accuracy
		$\theta$
$\varnothing 20$	Slide bush	$\pm 0.08^\circ$
	Linear bearing	$\pm 0.03^\circ$
$\varnothing 32$	Slide bush	$\pm 0.07^\circ$
	Linear bearing	$\pm 0.03^\circ$
$\varnothing 40$	Slide bush	$\pm 0.06^\circ$
	Linear bearing	$\pm 0.03^\circ$
$\varnothing 50$	Slide bush	$\pm 0.05^\circ$
	Linear bearing	$\pm 0.02^\circ$
$\varnothing 63$	Slide bush	$\pm 0.05^\circ$
	Linear bearing	$\pm 0.02^\circ$
$\varnothing 80$	Slide bush	$\pm 0.04^\circ$
	Linear bearing	$\pm 0.02^\circ$

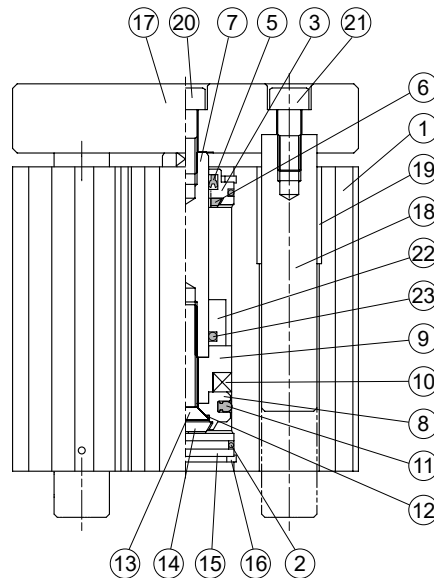

### Material

No.	Part name	Material	Qty	Repair kits (inclusion)
1	Body	Aluminum alloy	1	
2	Cover ring	NBR	2	●
3	Rod cover	Aluminum alloy	1	
4	Rod bush	Bearing alloy	1	
5	Rod packing	NBR	1	●
6	Rod cushion	NBR	1	●
7	Piston rod	Carbon steel	1	
8	Piston	Aluminum alloy	1	
9	Piston for magnet ring	Aluminum alloy	1	
10	Magnet ring	Magnet material	1	
11	Piston packing	NBR	1	●
12	Piston gasket	NBR	1	●
13	Bolt for piston	Carbon steel	1	
14	Head cushion	NBR	1	●
15	End cover	Aluminum alloy	1	
16	Snap ring	Spring steel	2	
17	Plate	Aluminum alloy	1	
18	Guide rod	Carbon steel	2	
19	Guide rod bush	Bearing alloy	4	
20	Bolt for piston rod	Carbon steel	1	
21	Bolt for guide rod	Carbon steel	2	
22	Spacer	Aluminum alloy	1	
23	O-ring	NBR	1	

### Order example of repair kits

Tube I.D.	Repair kits
ø20	<b>PS-MCGA-20</b>
ø32	<b>PS-MCGA-32</b>
ø40	<b>PS-MCGA-40</b>
ø50	<b>PS-MCGA-50</b>
ø63	<b>PS-MCGA-63</b>
ø80	<b>PS-MCGA-80</b>

### Stop type

#### MCGA-03

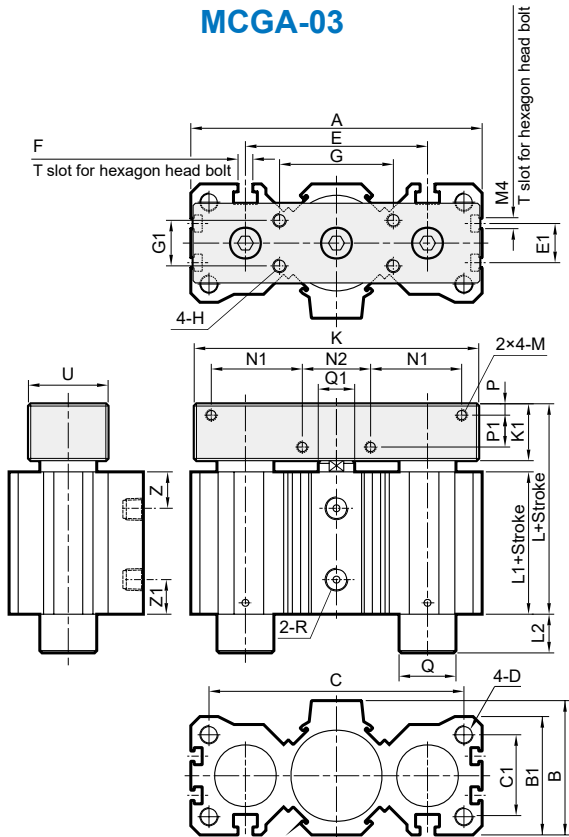

### Lift type

#### MCGA-53/13

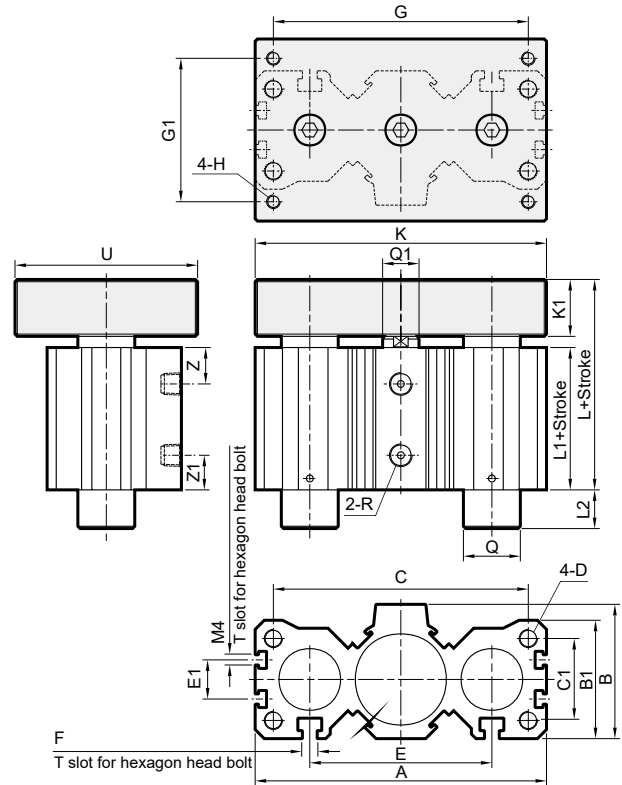

### MCGA-03

Code Tube I.D.	A	B	B1	C	C1	D	E	E1	F	G	G1	H	K	K1	L	L1	M	N1	N2	P	P1	Q	Q1	R	U	Z	Z1
20	75	34	32	63	20	M5×0.8×15dp	45	—	M4	32	16	M5×0.8×10dp	75	15	54	36	M4×0.7×8dp	22.5	20	4	6	ø12	ø10	Rc1/8	25	11	10
32	106	51.5	45	90	30	M8×1.25×20dp	63	—	M6	40	18	M6×1.0×12dp	100	20	66.5	41.5	M5×0.8×10dp	32	25	5	9	ø20	ø16	Rc1/8	30	12	12
40	128	59	52	112	36	M8×1.25×20dp	80	—	M6	50	20	M6×1.0×12dp	125	25	81	51	M5×0.8×10dp	40	30	5	14	ø25	ø16	Rc1/8	35	16	16.5
50	150	69	62	132	45	M10×1.5×25dp	100	20	M8	63	25	M8×1.25×16dp	140	30	87	52	M6×1.0×12dp	37.5	50	6	16	ø30	ø20	Rc1/4	40	16	17.5
63	180	87	78	156	53	M12×1.75×30dp	118	25	M10	80	40	M10×1.5×20dp	175	35	100	60	M8×1.25×16dp	47.5	60	9	16	ø35	ø20	Rc1/4	60	17.5	21
80	243	110	100	212	71	M16×2.0×40dp	160	30	M12	106	56	M10×1.5×20dp	224	40	110.5	62.5	M10×1.5×20dp	60	80	10	18	ø45	ø25	Rc3/8	75	22	19.5

### L2 dimensions list

#### MCGA-53/13

Code Tube I.D.	G	G1	K	Q	U
20	63	32	75	ø12 (ø8)	45
32	90	50	106	ø20 (ø13)	70
40	112	63	128	ø25 (ø16)	80
50	132	71	150	ø30 (ø20)	100
63	150	85	175	ø35 (ø25)	110
80	212	125	236	ø45 (ø35)	150

( ): For MCGA-13 type

#### MCGA-03/53

Code Tube I.D.	Stroke (mm)			
	30	50	75	100
20	0	17	17	17
32	0	18.5	18.5	18.5
40	0	0	22	22
50	0	0	18	18
63	20	20	20	20
80	0	0	38.5	38.5

#### MCGA-13

Code Tube I.D.	Stroke (mm)			
	30	50	75	100
20	18	18	18	18
32	29.5	29.5	29.5	29.5
40	30	30	30	30
50	—	39	39	39
63	11	11	70	70
80	19.5	19.5	19.5	89.5