



Applications



Rod end shape





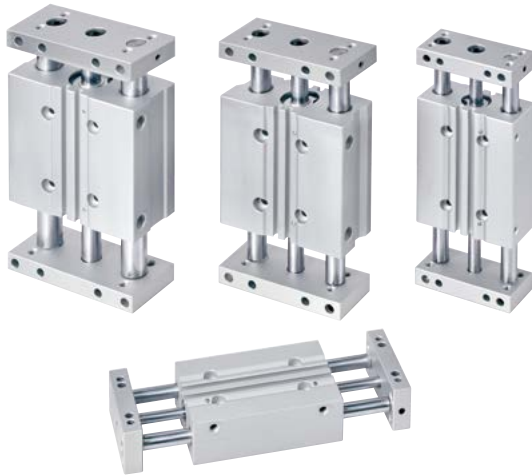

Caution for safety  
(Read before installing)

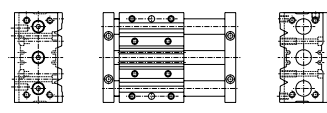

### Features

- Can be used as plate slide type or body slide type.
- The air cylinder and guide share a compact design which enables the cylinder to work smoothly along its stroke.
- The cylinder is extremely rigid and strong.
- Flush fitting sensor available.
- Magnetic as standard.

### Specification

Model	MCGD	
Model (Stop type view)		
Acting type	Double acting	
Tube I.D.(mm)	12,16	20,25,32
Port size	M5×0.8	Rc1/8
Medium	Air	
Operating pressure range	0.1~1 MPa	
Proof pressure	1.5 MPa	
Ambient temperature	-5~+60°C (No freezing)	
Cushion	With rubber cushion pad	
Available speed range	50~500 mm/sec	
Lubrication	Not required	
Sensor switch	RCE  , RCE1  , RDEP 	

### Order example

**MCGD — 03 — 12 — 50 — □**

MODEL                      TUBE I.D.    STROKE                      PORT THREAD

TYPE OF BEARING

Blank: M5×0.8  
(for ø12,ø16)  
Blank: Rc thread  
G: G thread  
NPT: NPT thread  
(for ø20~ø32)

Code	Type of bearing
03	Slide bush
23	Linear bearing

### Installation of sensor switch

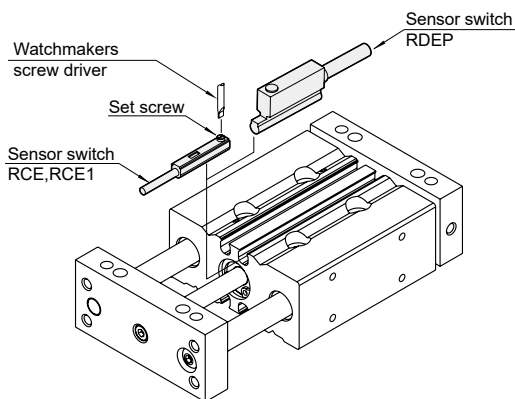

### Table for standard stroke

Series variety (Bearing type)	Tube I.D.	Stroke (mm)									
		30	50	75	100	125	150	175	200	250	300
MCGD-03 (Slide bush)	ø12	■	■	■	■	■	■	■	■	■	■
	ø16	■	■	■	■	■	■	■	■	■	■
	ø20	■	■	■	■	■	■	■	■	■	■
	ø25	■	■	■	■	■	■	■	■	■	■
	ø32	■	■	■	■	■	■	■	■	■	■
MCGD-23 (Linear bearing)	ø12	■	■	■	■	■	■	■	■	■	■
	ø16	■	■	■	■	■	■	■	■	■	■
	ø20	■	■	■	■	■	■	■	■	■	■
	ø25	■	■	■	■	■	■	■	■	■	■
	ø32	■	■	■	■	■	■	■	■	■	■

\* Please contact us if the stroke is out of specification.

**TWIN-GUIDE SLIDE CYLINDER**

**Deflection of guide rod by center loading (Reference)**

**Body Fixed**

When center loading is exerted to the center of the plate.

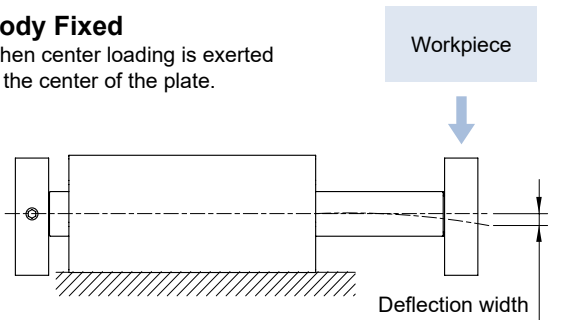

Unit: mm

Tube I.D.	Bearing type	Stroke Load (kgf)	Deflection width			
			50	100	150	200
$\phi 12$	Slide bush	0.5	0.09	0.22	—	—
	Linear bearing	0.3	0.08	0.3	—	—
$\phi 16$	Slide bush	0.5	0.03	0.1	0.25	—
	Linear bearing	0.5	0.09	0.22	0.5	—
$\phi 20$	Slide bush	0.8	0.03	0.09	0.18	—
	Linear bearing	0.5	0.03	0.1	0.25	—
$\phi 25$	Slide bush	1	0.03	0.09	0.16	—
	Linear bearing	0.8	0.03	0.09	0.18	—
$\phi 32$	Slide bush	2.9	0.02	0.05	0.1	0.15
	Linear bearing	1	0.03	0.09	0.16	0.25

**Plate Fixed**

When center loading is exerted to the center of the Body.

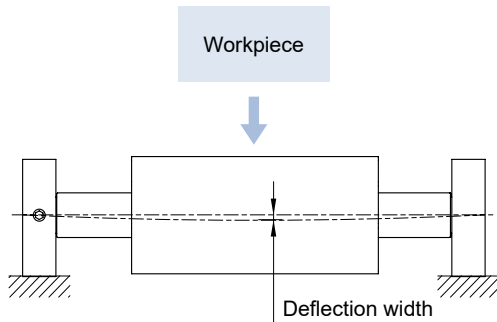

Unit: mm

Tube I.D.	Bearing type	Stroke Load (kgf)	Deflection width			
			50	100	150	200
$\phi 12$	Slide bush	3	0.06	0.08	—	—
	Linear bearing	1	0.05	0.07	—	—
$\phi 16$	Slide bush	4	0.06	0.08	0.15	—
	Linear bearing	3	0.06	0.08	—	—
$\phi 20$	Slide bush	5	0.05	0.06	0.12	—
	Linear bearing	4	0.06	0.08	0.15	—
$\phi 25$	Slide bush	6	0.04	0.05	0.07	—
	Linear bearing	5	0.05	0.06	0.12	—
$\phi 32$	Slide bush	9	0.02	0.03	0.06	0.07
	Linear bearing	6	0.04	0.05	0.07	0.08

**Plate mounting methods**

**A Fixing the Body**  
The plate moves.

Mounting from the upper side

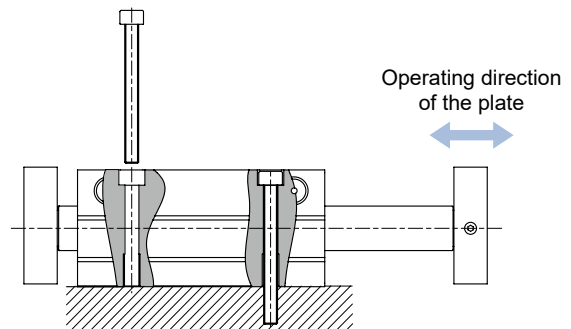

Mounting from the bottom side

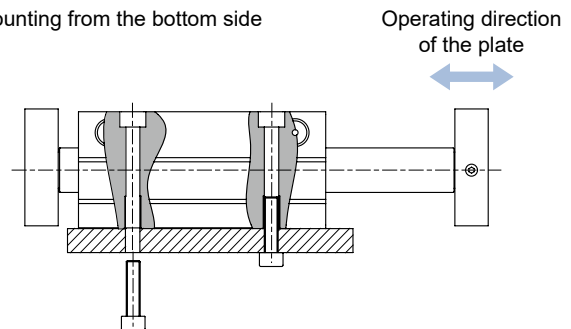

**B Fixing the Plate**  
The body moves.

Mounting from the upper side

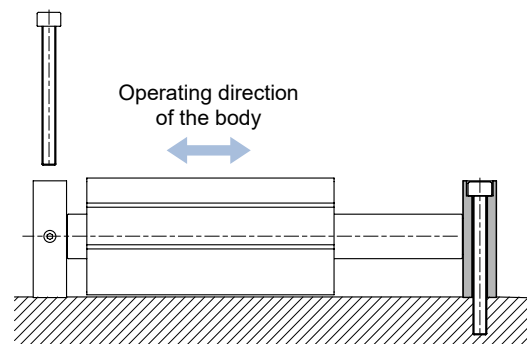

## TWIN-GUIDE SLIDE CYLINDER

### Maximum allowable moment

Please operate within the maximum allowable moment.

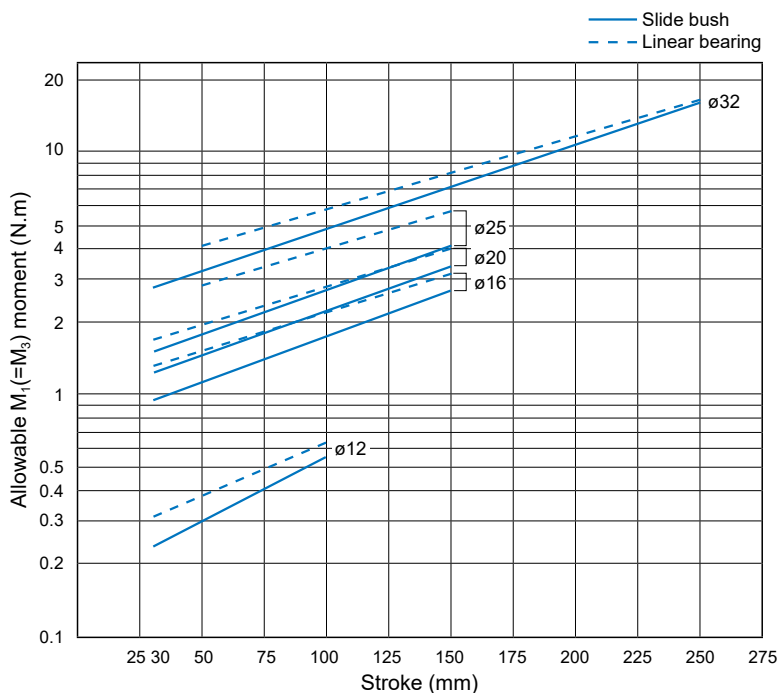
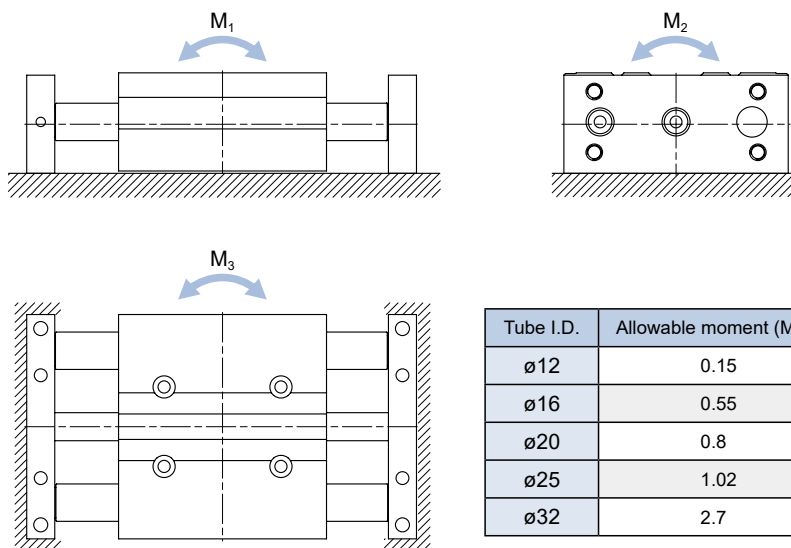

### Anti-roll accuracy

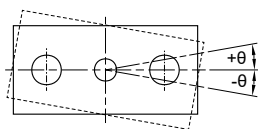

- The values are the deflection angle against the piston rod.
- Exclusive factor of the guide rods' deflection.

Tube I.D.	Bearing type	Anti-roll accuracy
		$\theta$
$\phi 12$	Slide bush	$\pm 0.09^\circ$
	Linear bearing	$\pm 0.06^\circ$
$\phi 16$	Slide bush	$\pm 0.08^\circ$
	Linear bearing	$\pm 0.06^\circ$
$\phi 20$	Slide bush	$\pm 0.08^\circ$
	Linear bearing	$\pm 0.03^\circ$
$\phi 25$	Slide bush	$\pm 0.07^\circ$
	Linear bearing	$\pm 0.05^\circ$
$\phi 32$	Slide bush	$\pm 0.07^\circ$
	Linear bearing	$\pm 0.03^\circ$

### MCGD-03

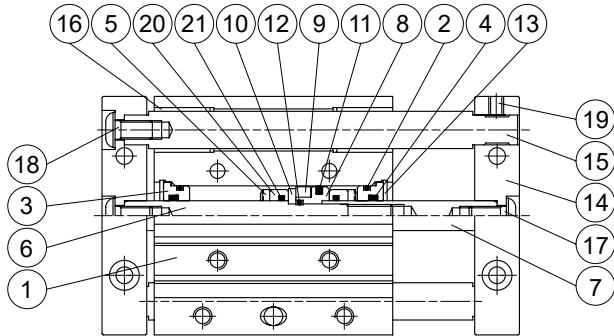

### MCGD-23

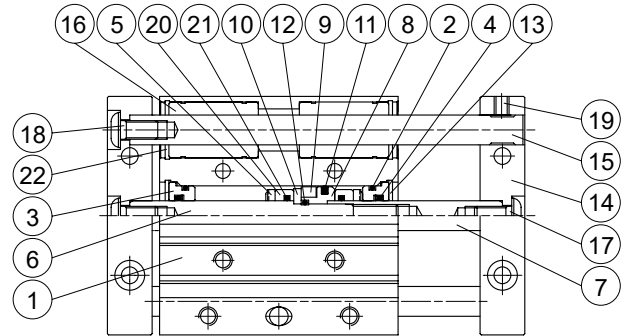

### Material

No.	Part name	Material	Note	Q'y	Repair kits (inclusion)
1	Body	Aluminum alloy		1	
2	Cover ring	NBR		2	●
3	Rod cover	Aluminum alloy		2	
4	Rod packing	NBR		2	●
5	Cushion	NBR		2	●
6	Piston rod #1	Carbon steel		1	
7	Piston rod #2	Carbon steel		1	
8	Piston	Aluminum alloy		1	
9	Magnet ring	Magnet material		1	
10	Magnet ring holder	Stainless steel		1	
11	Piston packing	NBR		1	●
12	Piston gasket	NBR		1	●
13	Snap ring	Spring steel		2	
14	Plate	Aluminum alloy		2	
15	Guide rod	Carbon steel	for <b>03</b> type	2	
		Special steel	for <b>23</b> type	2	
16	Slide bush	Bearing alloy	for <b>03</b> type	4	
	Linear bearing	—	for <b>23</b> type	4	
17	Bolt for piston rod	Carbon steel		2	
18	Bolt for guide rod	Carbon steel		4	
19	Set screw	Carbon steel		2	
20	Spacer	Aluminum alloy		2	
21	O-ring	NBR		2	
22	Snap ring	Spring steel	for <b>23</b> type	4	

### Order example of repair kits

Tube I.D.	Repair kits
ø12	<b>PS-MCGD-12</b>
ø16	<b>PS-MCGD-16</b>
ø20	<b>PS-MCGD-20</b>
ø25	<b>PS-MCGD-25</b>
ø32	<b>PS-MCGD-32</b>

MCGD-03/23

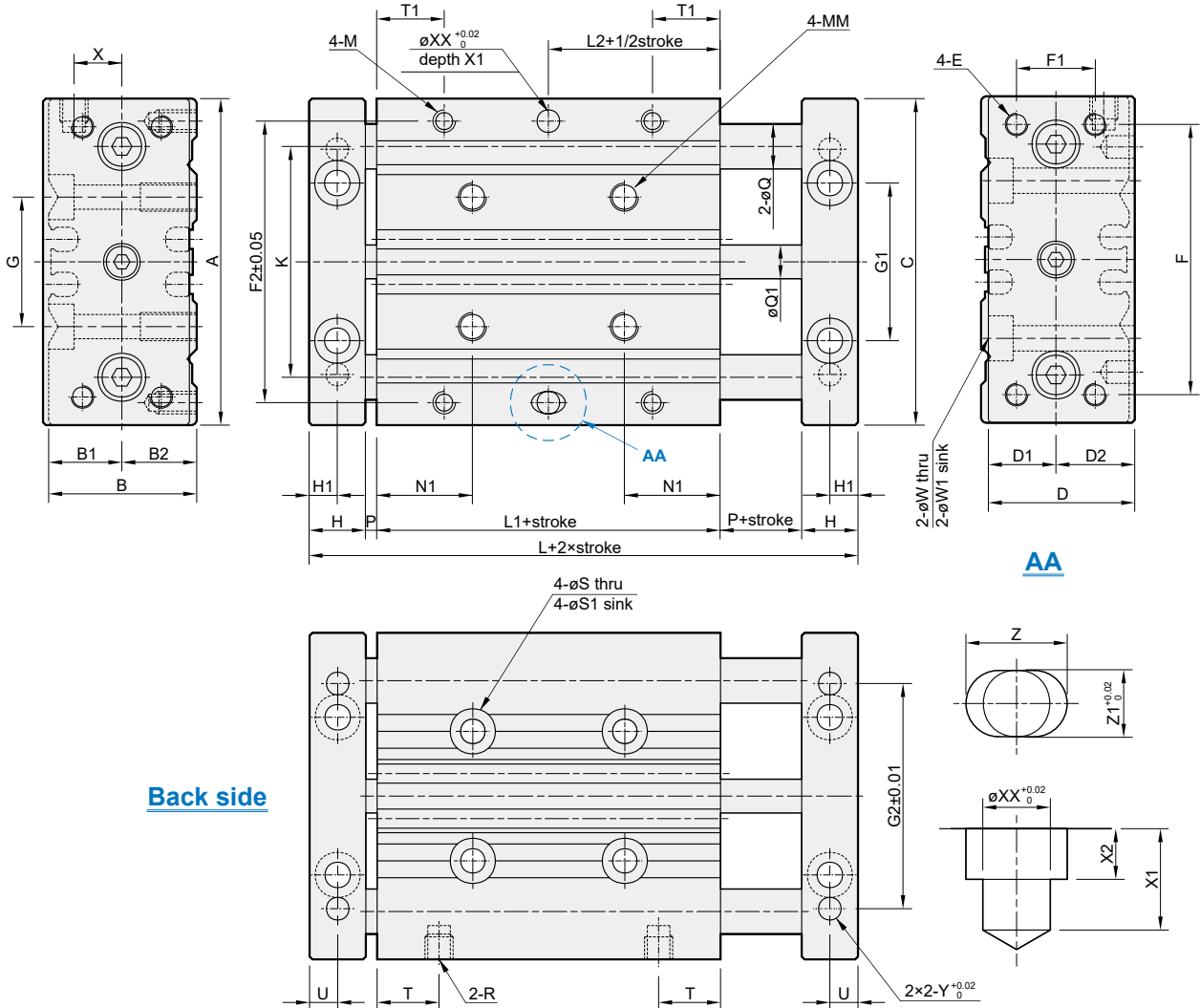

Back side

Code Tube I.D.	A	B	B1	B2	C	D	D1	D2	E	F	F1	F2	G	G1	G2	H	H1	K	L	L1	L2	M	MM	N1	Q		Q1	P	R
																								MCGD-03	MCGD-23				
12	58	26	13	13	58	26	12	14	M4	48	14	50	23	28	40	10	5	41.5	55	31	15.5	M4×7dp	M5×10dp	17	ø8	ø6	ø6	2	M5
16	64	30	15	15	64	30	14	16	M5	52	16	54	24	32	50	12	6	46	62	34	17	M5×7dp	M5×10dp	17	ø10	ø8	ø8	2	M5
20	85	36	19	17	85	36	16	20	M5	60	18	64	28	37	70	12	6	55	66	38	19	M5×7dp	M6×12dp	20.5	ø12	ø10	ø10	2	Rc1/8
25	96	42	21	21	96	42	20	22	M6	70	26	76	34	44	84	12	6	65	67	39	19.5	M6×9dp	M6×12dp	19.5	ø16	ø13	ø12	2	Rc1/8
32	116	51	25	26	116	51	24	27	M8	96	30	100	42	56	76	14	7	80	68	36	18	M8×11dp	M8×16dp	20	ø20	ø16	ø16	2	Rc1/8

Code Tube I.D.	S	S1	T	T1	U	W	W1	X	XX	X1	X2	Y	Z	Z1
12	ø4.3	ø8×4.5dp	11	12	5	ø4.5	ø8×4.5dp	8.5	ø4	6	3	ø4×5dp	6	4
16	ø4.3	ø8×4.5dp	11	13	6	ø4.5	ø8×4.5dp	10	ø5	6	3	ø5×5dp	7	5
20	ø5.2	ø9.5×5.5dp	13.5	14	6	ø5.5	ø9.5×5.5dp	11.5	ø6	8	4	ø6×8dp	8	6
25	ø5.2	ø9.5×5.5dp	11	12	6	ø5.5	ø9.5×5.5dp	13.5	ø6	8	4	ø6×8dp	8	6
32	ø6.8	ø11×6.5dp	11	16.5	7	ø6.6	ø11×6.5dp	16	ø8	12	6	ø8×12dp	10	8