

Features

- Rack and pinion construction enable synchronisation of both jaws enabling smooth and consistent gripping force.
- Wide range of strokes available.
- Dust seals protect all internal parts from ingress of dirt.
- Proximity and reed switches can be used with this unit.
- Magnetic as standard.

Specification

Model	MCHX					
Acting type	Double acting					
Tube I.D. (mm)	10	16	20	25	32	40
Medium	Air					
Operating pressure range	0.2~0.6 MPa					
Ambient temperature	-5~+60°C (No freezing)					
Lubrication	Not required					
Repeatability	±0.1 mm					
Sensor switch (*)	2 wire	RDVE(V): Non-contact				
	3 wire	RNFE(V): NPN, RPFE(V): PNP				

Order example

MCHX – 16 – 30 M

MODEL

TUBE I.D.	STROKE
10	20, 40, 60
16	30, 60, 80
20	40, 80, 100
25	50, 100, 120
32	70, 120, 160
40	100, 160, 200

M: Magnet

* Magnetic as standard.

* R*FE(V) specification, please refer to page 5-11.

Weight

Model	MCHX-10			MCHX-16			MCHX-20			MCHX-25			MCHX-32			MCHX-40		
Stroke (mm)	20	40	60	30	60	80	40	80	100	50	100	120	70	120	160	100	160	200
Max. operating frequency (c.p.m)	60	40	40	60	40	40	60	40	40	60	40	40	30	20	20	30	20	20
Weight (kg)	0.28	0.35	0.44	0.56	0.8	0.94	1.0	1.5	1.68	1.69	2.8	3.0	3.15	4.36	5.02	5.3	6.8	8.6

Mounting

Axial mounting

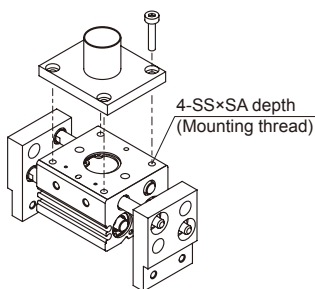

Tube I.D.	SA	SS	Max. tightening torque (N.m)
10	8	M4×0.7	2.1
16	10	M5×0.8	4.3
20	12	M6×1.0	7.3
25	16	M8×1.25	17.7
32	16	M8×1.25	18
40	20	M10×1.5	36

Axial mounting

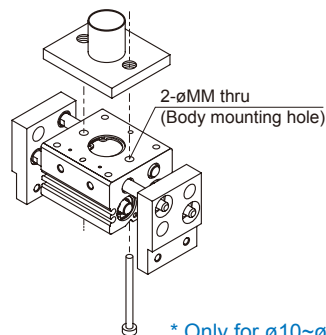

* Only for ø10~ø25.

Tube I.D.	MM	Bolt	Max. tightening torque (N.m)
10	4.5	M4×0.7	2.1
16	5.5	M5×0.8	4.3
20	6.6	M6×1.0	7.3
25	9	M8×1.25	17.7
32	–	–	–
40	–	–	–

Lateral mounting

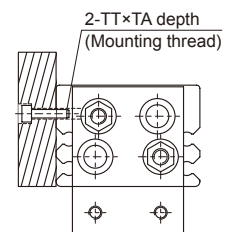

Tube I.D.	TA	TT	Max. tightening torque (N.m)
10	5	M4×0.7	1.4
16	7	M5×0.8	2.8
20	7	M6×1.0	4.8
25	7	M8×1.25	12
32	11	M8×1.25	12
40	12	M10×1.5	24

WIDE TYPE PARALLEL GRIPPER (2-Finger)

mindman

ø10

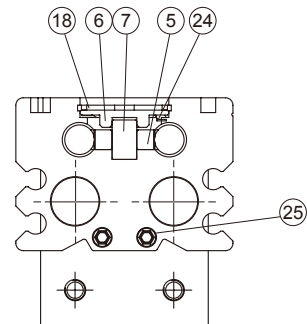
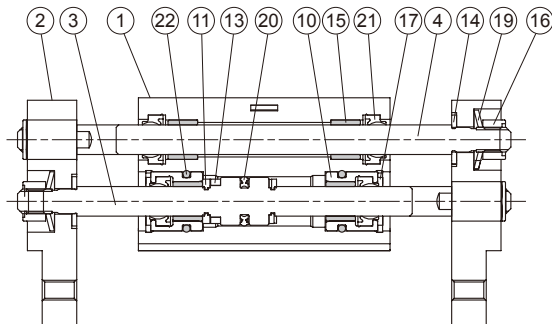

ø16~ø40

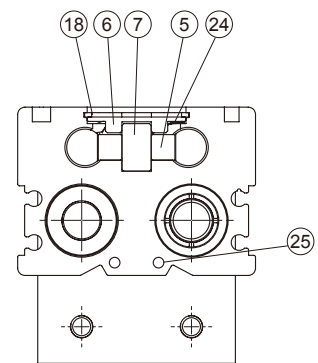
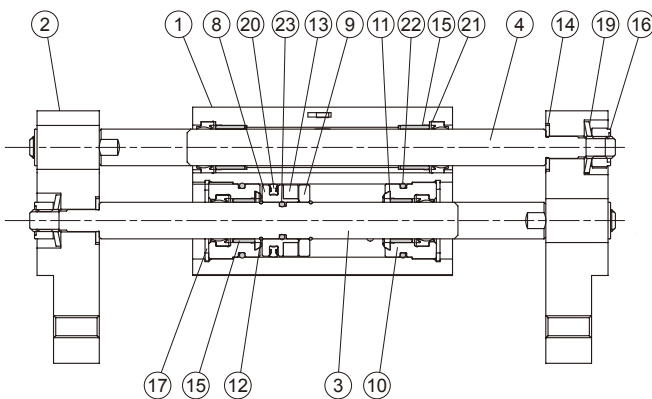

Material

No.	Tube I.D. Part name	10	16	20	25	32	40	Q'y	Repair kits (inclusion)
1	Body	Aluminum alloy						1	
2	Finger	Aluminum alloy						2	
3	Piston rod	Stainless steel						2	
4	Rack	Stainless steel						2	
5	Pinion	Carbon steel						1	
6	Pinion cover	Carbon steel						1	
7	Pinion axis	Stainless steel						1	
8	Piston	–	Brass				2		
9	Magnet holder	–	Brass				2		
10	Rod cover	Aluminum alloy						4	
11	Damper	NBR	PU	NBR			4	●	
12	Stop ring	–	Spring steel				4		
13	Magnet	Magnet material						2	
14	Washer	Stainless steel			Carbon steel			4	
15	Bearing	Oil containing polyacetal with back metal						8	
16	U nut	Carbon steel						4	
17	R-shape snap ring	*1	*2	Carbon steel		*2	4		
18	C-shape snap ring	Carbon steel						1	
19	Conical spring washer	Stainless steel *3						4	
20	Piston packing	NBR						2	●
21	Rod packing	NBR						8	●
22	O-ring	NBR						4	●
23	O-ring	–	NBR				2		
24	Wave washer	Carbon steel						1	
25	Screw	*1	–	Carbon steel			4		
	Ball	–	SUS	–			4		

Order example of repair kits

Tube I.D.	Repair kits
ø10	PS-MCHX-10
ø16	PS-MCHX-16
ø20	PS-MCHX-20
ø25	PS-MCHX-25
ø32	PS-MCHX-32
ø40	PS-MCHX-40

*1. Carbon steel

*2. Stainless steel

*3. ø40: Stainless steel 2 pcs + Carbon steel 2 pcs

Model selection example

* Finger selection please refer to page 3-2.

In the motion process did not produce high acceleration, deceleration or impact forces, Workpiece mass: 0.3kg , Gripping method: External gripping, Operating pressure: 0.5 MPa, Coefficient of friction (μ): 0.1, Holding position: L=20mm (no overhang)

- Based on the above formula, the required gripping force can be derived:

$$F \geq \frac{0.3 \times 9.8}{2 \times 0.1} \times 4 \geq 60(N)$$
- From Effective Gripping Force Fig. Operating pressure: 0.5 MPa; Holding position: 20 mm Effective gripping force is greater than 60 (N) So selected **MCHX-20-40** grippers.

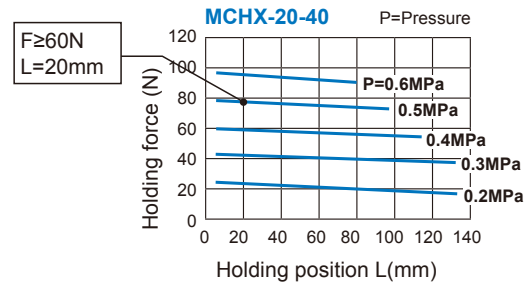

Model selection suggestions

- For normal gripping and carrying usage, the recommended safe factor (a) is 4.
- The value of gripping force of single finger can be found at the gripping force table.
- The safe factor (a) have to be higher if the gripper is using with a great accelerated velocity or impaction condition.

Mounting precautions

- To prevent bending the piston rod, please mount the attachment when finger is closing.
- Do not scratch or dent the sliding portion of the piston rod, or it may cause air leaks or faulty operation.
- Refer to the table below for the proper tightening torque on the bolt used for securing the attachment to the finger.

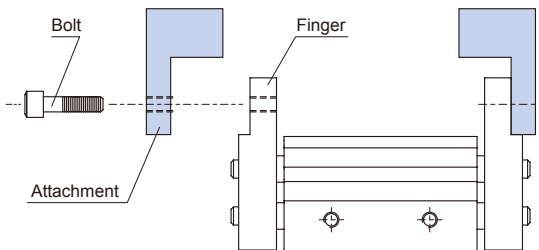

Tube I.D.	Bolt	Max. tightening torque (N.m)
10	M4×0.7	1.4
16	M5×0.8	2.8
20	M6×1.0	4.8
25	M8×1.25	12
32	M10×1.5	24
40	M12×1.75	42.2

Effective gripping force

Indication of effective force.

The effective gripping force shown in the graphs to the right is expressed as F, which is the thrust of one finger, when both fingers and attachments are in full contact with the workpiece as shown in the figure below.

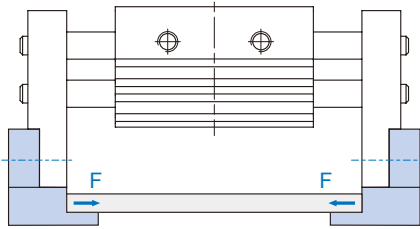

$$1\text{N} = 0.102 \text{ kgf}$$

$$1\text{MPa} = 10.2 \text{ kgf/cm}^2$$

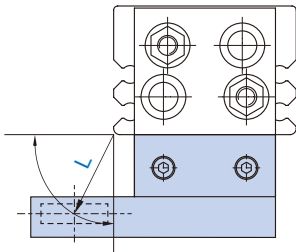

L: Holder position (mm)

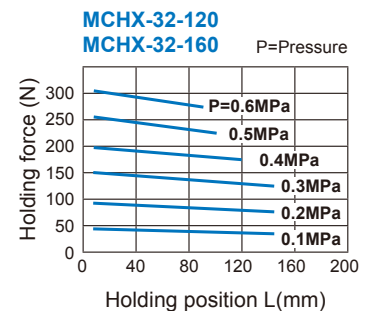
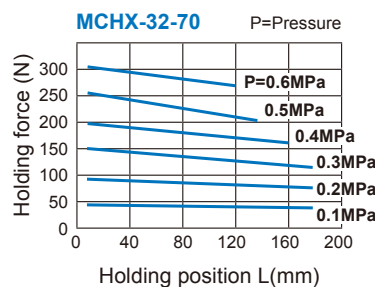
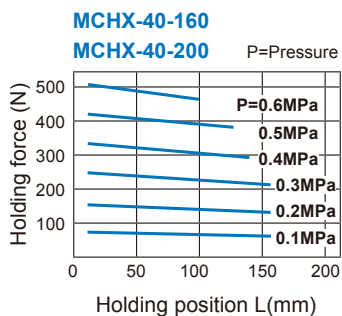
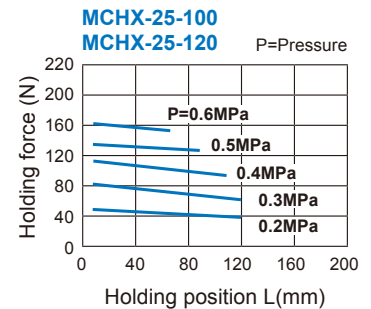
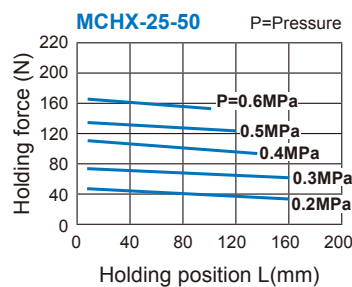
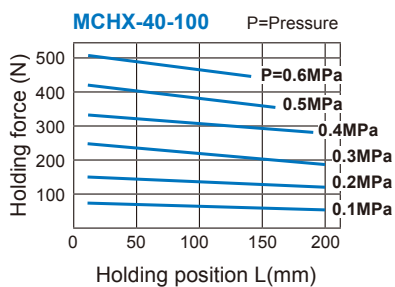
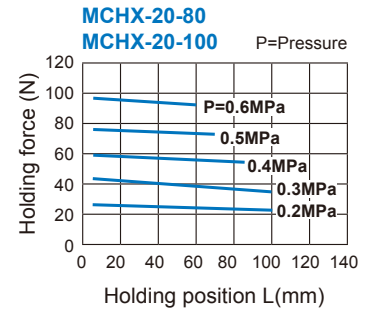
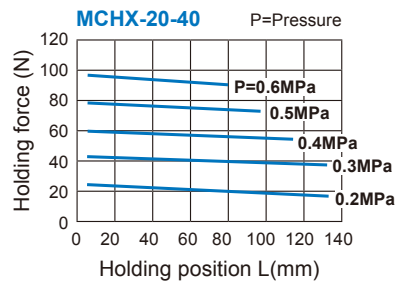
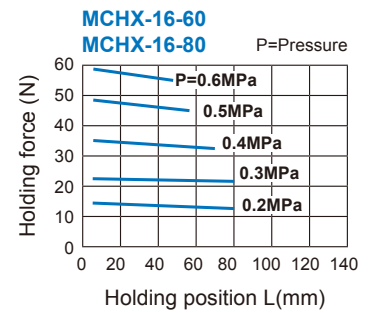
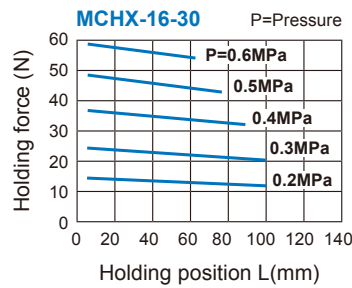
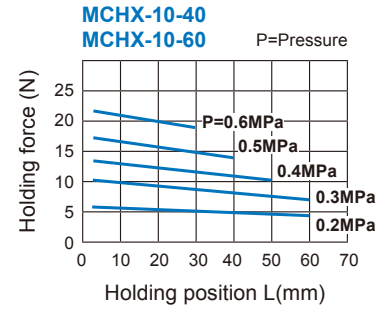
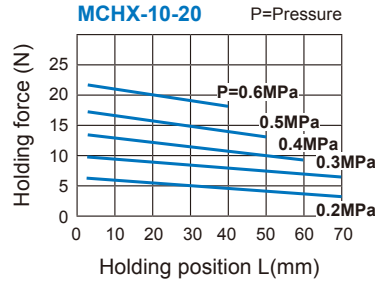

WIDE TYPE PARALLEL GRIPPER (2-Finger)

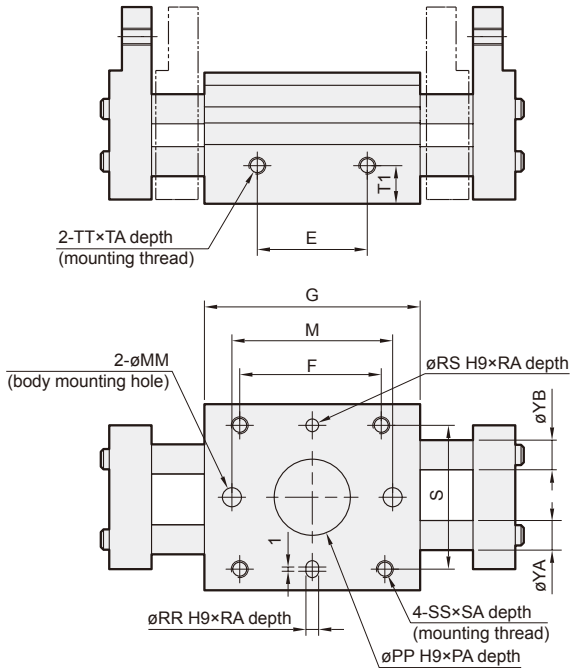

Code Tube I.D.	Stroke	A	B	DA	DB	E	F	G	M	P1	P2
10	20	76	56	100	80	26	36	51	38	11.5	11.5
	40	118	78	142	108	42	52	67	54	19.5	19.5
	60	156	96	180	146	60	70	85	72	28.5	28.5
16	30	98	68	128	98	28	45	60	40	13	13
	60	170	110	200	152	58	75	90	70	25	25
	80	210	130	240	192	78	95	110	90	35	35
20	40	122	82	160	120	38	58	71	54	16	16
	80	222	142	260	194	80	100	113	96	34	34
	100	262	162	300	234	100	120	133	116	44	44
25	50	150	100	196	146	48	70	88	66	19	19
	100	282	182	328	244	102	124	142	120	43	43
	120	320	200	366	282	120	142	160	138	52	52
32	70	220	150	272	202	60	86	110	—	28	28
	120	318	198	370	282	108	134	158	—	52	52
	160	402	242	454	366	152	178	202	—	74	74
40	100	288	188	348	252	80	116	148	—	36	36
	160	406	246	466	370	138	174	206	—	65	65
	200	486	286	546	450	178	214	246	—	85	85

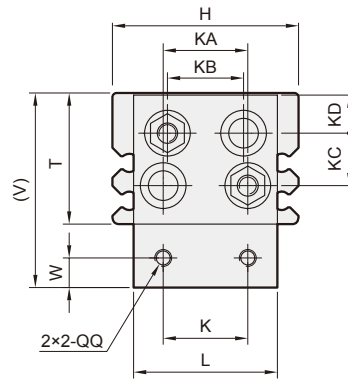
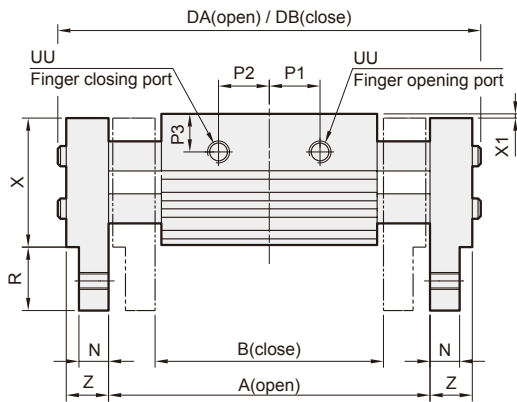

Code Tube I.D.	H	K	KA	KB	KC	KD	L	N	MM	PA	PP	P3	QQ	R	RA	RR	RS	S	SA	SS
10	44	20	20	18.2	12.5	8	34	7	4.5	1.5	18	9	M4×0.7	15	3	3	3	34	8	M4×0.7
16	55	25	25	22.6	16.5	9	43	9	5.5	1.5	23	10	M5×0.8	19	3	3	3	42	10	M5×0.8
20	65	30	30	28.2	20	10	54	12.5	6.6	1.5	24	11	M6×1.0	24	4	4	4	52	12	M6×1.0
25	76	40	38	33.2	23.5	11.5	64	14	9	1.5	32	16	M8×1.25	29	4.5	4	4	62	16	M8×1.25
32	82	50	40	32.2	30	14.5	70	15	—	2.5	35	16	M10×1.5	32	8	6	6	64	16	M8×1.25
40	98	60	48	40.2	37	16	86	18	—	2.5	40	18	M12×1.75	38	8	6	6	76	20	M10×1.5

Code Tube I.D.	T	T1	TA	TT	UU	V	W	X	X1	YA	YB	Z
10	31	9	5	M4×0.7	M5×0.8	46	7	30.5	0.5	6	6	10
16	39	10	7	M5×0.8	M5×0.8	58	8	38.5	0.5	8	8	13
20	46	11	7	M6×1.0	M5×0.8	70	10	45	1	10	10	17
25	52	12.5	7	M8×1.25	M5×0.8	81	12	51	1	12	12	21
32	68	22	11	M8×1.25	Rc1/8	100	15	67	1	14	16	24
40	79	28	12	M10×1.5	Rc1/8	117	18	78	1	16	20	28