

MCHY2 series

180° ANGULAR GRIPPER - CAM STYLE



Model selection



Technical data



Caution for safety
(Read before installing)



Order example

MCHY2 – 16 D 1

MODEL

TUBE I.D.

10
16
20
25

D: Double acting

FINGER OPTION

Standard tap mounting

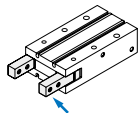

1
Opening / closing direction through hole.

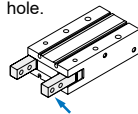

Features

- Compact design and lightweight construction.
- High gripping forces achieved via internal cams. Reduced required offset while moving gripper. (Fig1).
- Reference points on gripping fingers are standard.
- Sensors can be mounted in any one of four positions.
- Rod seal prevents foreign objects to enter piston.
- Magnetic as standard.

Specification

Model	MCHY2			
Acting Type	Double acting			
Tube I.D. (mm)	10	16	20	25
Medium	Air			
Operating pressure range	0.2~0.6 MPa			
Ambient temperature	-10~+60°C (No freezing)			
Repeatability	±0.2 mm			
Max. operating frequency (c.p.m)	60 (*1)			
Lubrication (*2)	Not required			
Effective force (Nm) at (0.5 MPa)	0.16	0.54	1.1	2.28
Operating angle (both sides)	Opened side	180°~182°		
	Closed side	-3°		
Sensor switch	RDC(V), RQC(V)			
Weight (g)	80	150	320	600

*1. Speed controllers are required.

*2. Sliding area of jaws need scheduled relubrication.

Fig1. Reduced required offset while moving gripper

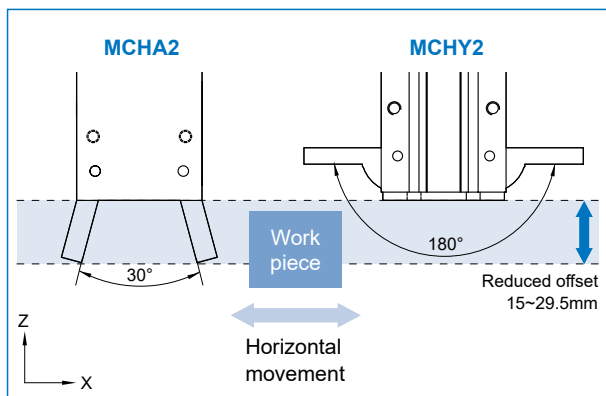

Installation of sensor switch & speed controller

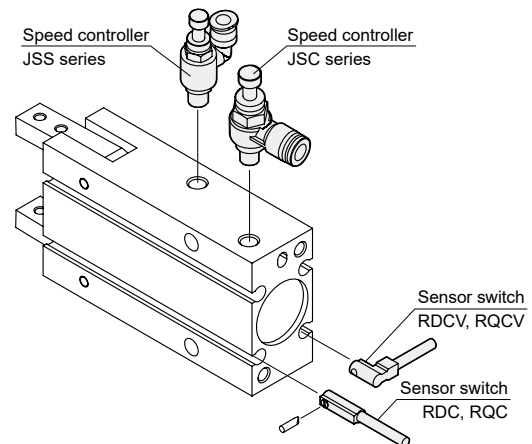

* Each gripper needs at least two speed control valves to operate.

* Speed controller specification

Effective gripping force

Indication of effective force.

The effective gripping force shown in the graphs to the right is expressed as F, which is the thrust of one finger, when both fingers and attachments are in full contact with the workpiece as shown in the figure below.

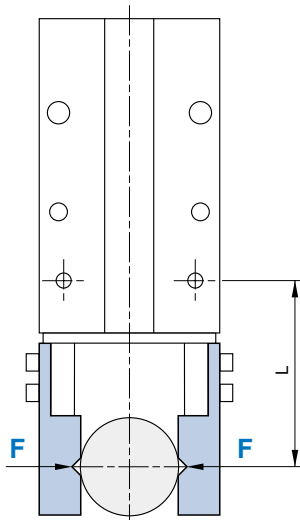

$1\text{N} = 0.102 \text{ kgf}$
 $1\text{MPa} = 10.2 \text{ kgf/cm}^2$

Confirmation of gripping point

- The air gripper should be operated so that the workpiece gripping point "L" and the amount of overhang "H" stay within the range shown for each operating pressure given in the graphs to the right.
- If the workpiece gripping point goes beyond the range limits, this will have an adverse effect on the life the air gripper.

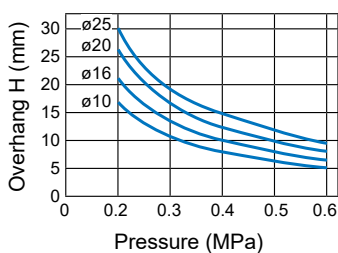
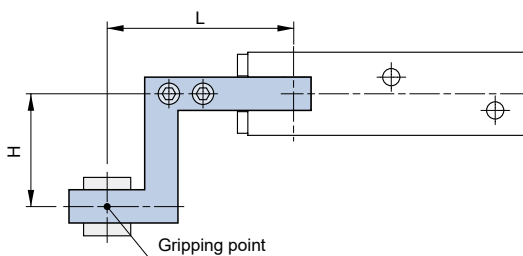

Gripping force

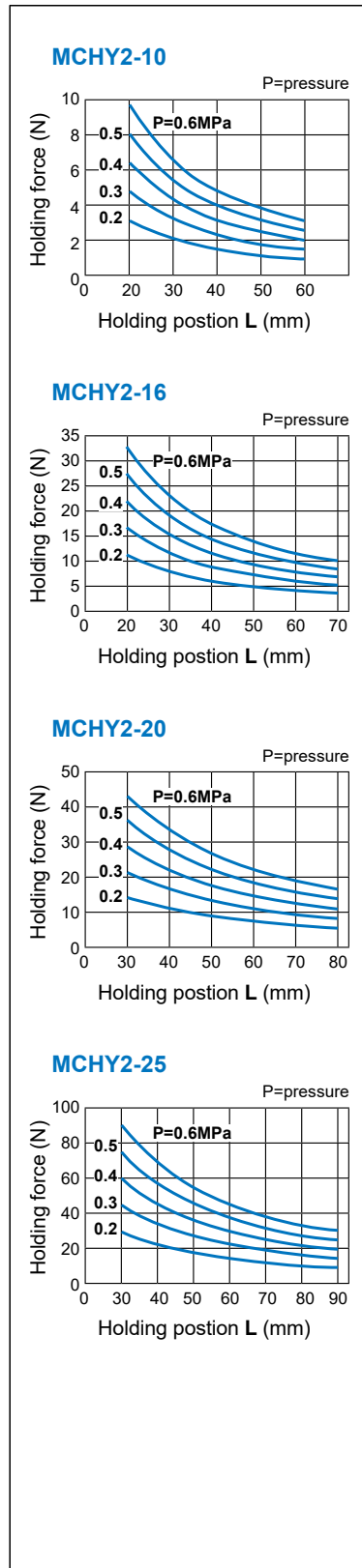

Moment of inertia

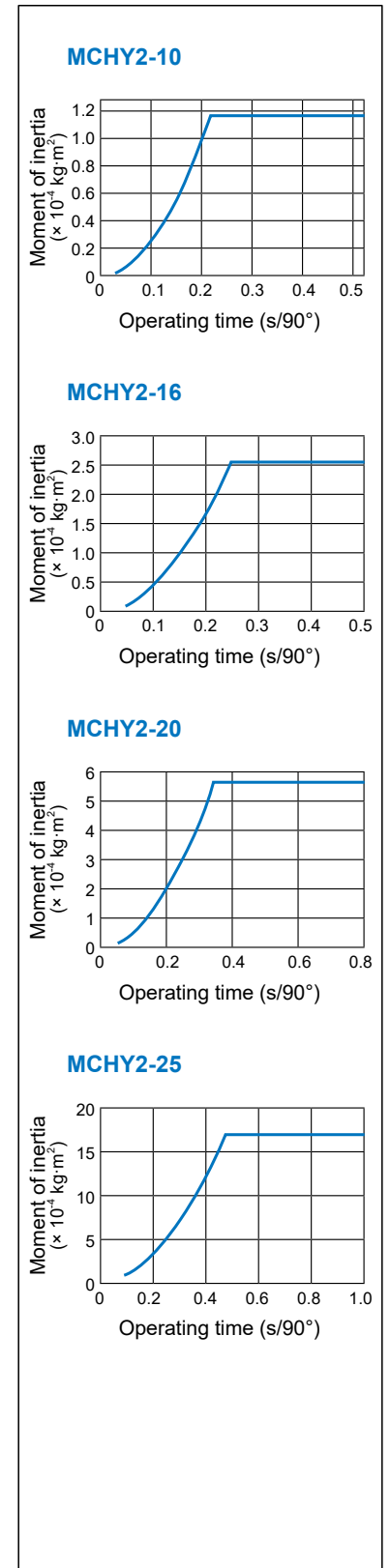

MCHY2 Inside structure & Parts list

180° ANGULAR GRIPPER - CAM STYLE



ø10

ø16~ø25

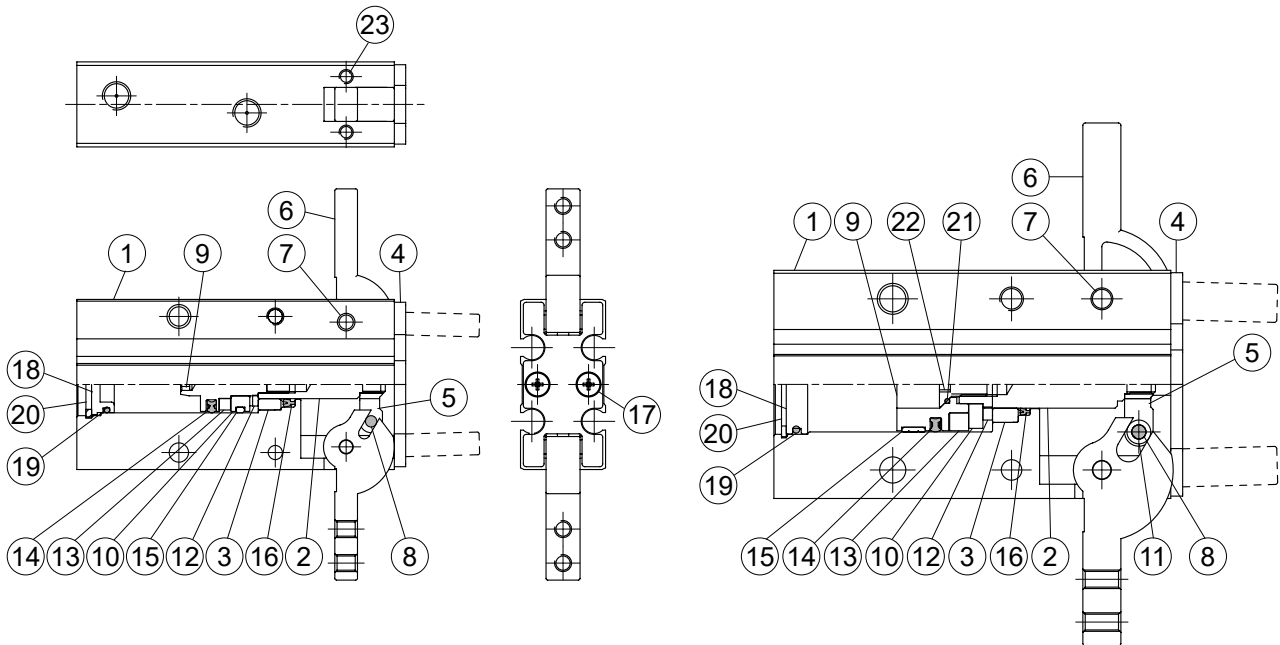

Material

No.	Tube I.D. Part name	10	16	20	25	Q'y	Repair kits (inclusion)
1	Body	Aluminum alloy				1	
2	Piston rod	Stainless steel				1	
3	Bushing	Brass				1	
4	Head cover	Stainless steel				1	
5	Lever	Stainless steel				1	
6	Gripper	Stainless steel				2	
7	Grip rivet	Carbon steel				2	
8	Pin	Carbon steel				2	
9	Piston	*1	Aluminum alloy			1	
10	Magnet holder	Stainless steel				1	
11	Pin bushing	-	SCM			2	
12	Cushion pad	NBR	PU			1	●
13	Magnet ring	Magnet material				1	
14	Piston packing	NBR				1	●
15	Wear ring	Resin				1	
16	Rod packing	NBR				1	●

No.	Tube I.D. Part name	10	16	20	25	Q'y	Repair kits (inclusion)
17	Screw	Stainless steel				2	
18	Rod cover	Aluminum alloy				1	
19	O-ring	NBR				1	●
20	Snap ring	*2	Stainless steel			1	
21	O-ring	-	NBR			1	●
22	Hexagon Bolt	-	Stainless steel			1	
23	ScREW	Stainless steel				4	

*1. Stainless steel *2. Carbon steel

Order example of repair kits

Tube I.D.	Repair kits
ø10	PS-MCHY-10
ø16	PS-MCHY-16
ø20	PS-MCHY-20
ø25	PS-MCHY-25

* Use the same repair kits with MCHY series.

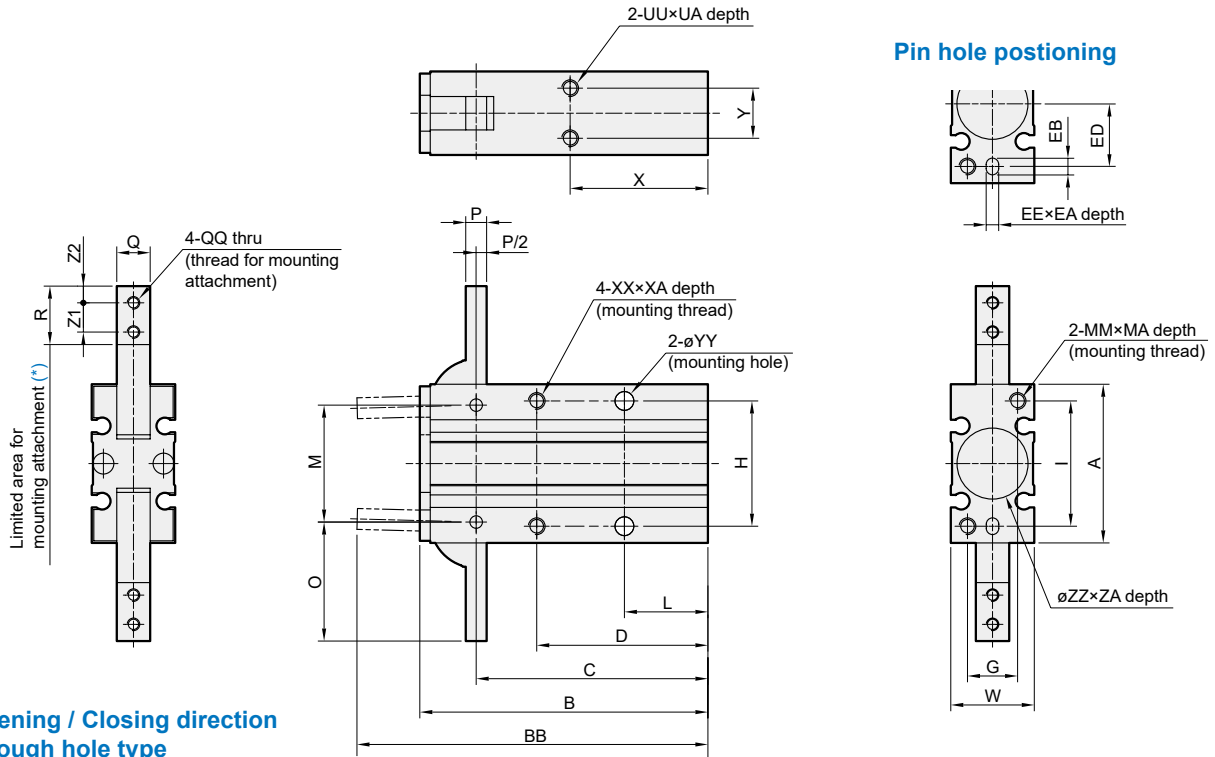

Opening / Closing direction through hole type

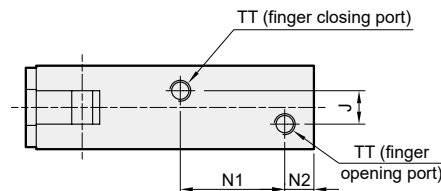
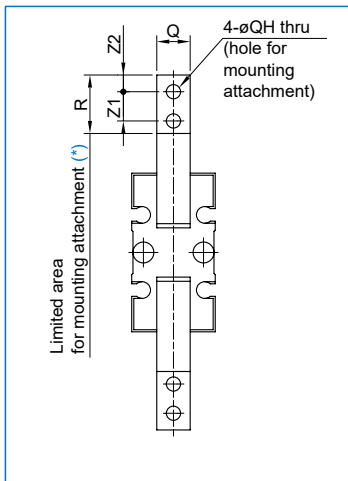

Auto switch mounting groove position

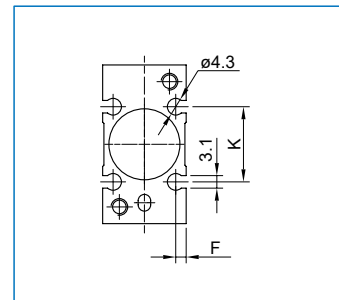

* Do not extend the attachment from limited area for mounting to avoid interference with the attachment or main body.

Code Tube I.D.	A	B	BB	C	D	EE	EA	EB	ED	F	G	H	I	J	K	L	M	MA	MM	N1	N2	O	P	Q	QH	QQ
10	30	58	71	47.5	35	3H9 ^{+0.025} ₋₀	3	4	9	2	9	24	24	3	13	18	22	6	M3×0.5	23	7	23.5	4	6 ^{-0.005} _{-0.025}	3.4	M3×0.5
16	38	69	84	55.5	41	3H9 ^{+0.025} ₋₀	3	4	15	2.5	12	30	30	8	18	20	28	8	M4×0.7	25	7	28.5	5	8 ^{-0.005} _{-0.025}	3.4	M3×0.5
20	48	86	106	69	50	4H9 ^{-0.030} ₋₀	4	5	19	3	16	36	38	12	20	25	36	10	M5×0.8	32	8	37	8	10 ^{-0.005} _{-0.025}	4.5	M4×0.7
25	58	107	131	86	60	4H9 ^{+0.030} ₋₀	4	5	23	3	18	42	46	14	24	30	45	12	M6×1	42	8	45	10	12 ^{-0.005} _{-0.025}	5.5	M5×0.8

Code Tube I.D.	R	TT	UA	UU	W	X	XA	XX	Y	YY	ZA	ZZ	Z1	Z2
10	12	M5×0.8	4	M3×0.5	15	30	6	M3×0.5	9	3.4	1.5	11H9 ^{+0.043} ₋₀	6	3
16	14	M5×0.8	5	M4×0.7	20	33	8	M4×0.7	12	4.5	1.5	17H9 ^{+0.043} ₋₀	7	4
20	18	M5×0.8	8	M5×0.8	26	42	10	M5×0.8	14	5.5	1.5	21H9 ^{+0.052} ₋₀	9	5
25	22.5	M5×0.8	10	M6×1	30	50	12	M6×1	16	6.6	1.5	26H9 ^{+0.052} ₋₀	12	6