



Special spec



Rod end shape



Technical data



Caution for safety
(Read before installing)



Table for standard stroke

Acting type	Tube I.D.	Stroke (mm)	Max. stroke (mm)
Single acting	13/15/23 ø16,20,25 ø32	15,25,50,75,100	150
Double acting	11 21/27 ø16,20,25 ø32,40	↑ 125,150,200, 300,400,500	1000
		↑ 125,150,200, 300,400	450

* Available with double action type cylinder with stroke more than 500 mm. Sub-piston increases the total length of cylinder by 10 mm and provides further stability.

* Intermediate stroke are available, please contact us.

Features

■ Non lubrication

- Special housing and bushing enable self lubrication of piston rod.

■ High quality long service life

- Hard anodised stainless steel cylinder tubes offer a high resistance to corrosion and low internal friction.
- Cylinder mountings, available with a comprehensive range of accessories for rigid or flexible mounting.
- Operation, with the exception of MCMA-11, single and doubling type available MCMA-13 / 15.

■ Magnetic as standard

Specification

Model	MCMA					
Tube I.D.	16	20	25	32	40	
Port size	M5×0.8	Rc1/8				
Medium	Air					
Max. operating pressure	0.7 MPa					
Min. operating pressure	Double: 0.06 MPa ; Single: 0.15 MPa					
Proof pressure	1 MPa					
Lubricator	Not required					
Ambient temperature	-5~+60°C (No freezing)					
Available speed range	50~750 mm/sec					
Max. allowable kinetic energy (J)	Cushion pad	0.16	0.27	0.4	0.65	1.2
	Cushion air	0.32	0.54	0.78	1.27	2.35
Sensor switch	RDC, RQC , RCM					
Sensor switch band	R*C	BKC-1 (Not for R*CV angle cable)				
	RCM	BM16	BM20	BM25	BM32	BM40

Order example

MCMA - 11 - 32 - 100 - A - 10 - N - □

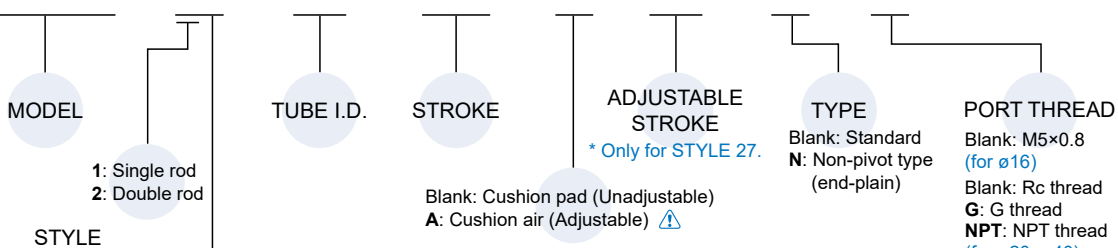

Code	Symbol	Description
1 1		Double acting / Male thread
1 3		Single acting / Normally extended male thread
1 5		Single acting / Normally returned male thread
2 1		Double rod / Male thread
2 3		Single acting / Double rod male thread
2 7		Double rod / Adjustable male thread

⚠ Caution

For (A) Cushion air (Adjustable)

1. To adjust a cushion needle, please slowly turn the needle valve from the fully closed status to the required status which needs to be within 2.5 turns.
2. If the needle valve loosen excessively, the buffer doesn't take effect and the lifetime of cylinder would be shortened.

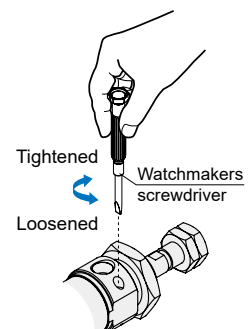

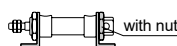
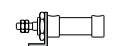
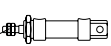
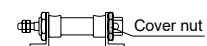

MINIATURE CYLINDER

Accessories & Connector

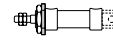
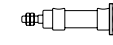
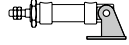
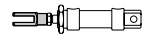
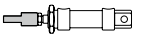
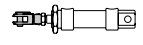
Accessories				
Code	LB (LB×2, with cover nut ×1)	LB (LB×1, without cover nut)	NUT	
Cover type	Standard type	Non-pivot type (N)	-	
Mounting Tube I.D.			Rod nut 	Cover nut 
ø16	LB-M1-16x2	LB-M1-16	NUT-M6x1.0x5Hx10B	NUT-M16x1.5x6Hx22B
ø20	LB-M3-20x2	LB-M3-20	NUT-M8x1.25x5Hx13B	NUT-M22x1.5x6Hx30B
ø25			NUT-M10x1.25x6Hx17B	
ø32	LB-M1-32x2	LB-M1-32	NUT-M24x2.0x8Hx32B	
ø40	LB-M1-40x2	LB-M1-40	NUT-M30x2.0x8Hx41B	

Accessories				Connector		
Code	FA	FB	SDB (with pin×1 + snap ring×2)	Y	I	YS (Y+Floating pin)
Cover type	All applicable	Standard type	Standard type	All applicable		
Mounting Tube I.D.						
ø16	FA-M3-12		SDB-M1-16	Y-M3-12	I-M3-12	YS-M3-16
ø20	FA-M3-20		SDB-M1-20	Y-M3-20	I-M3-20	YS-M3-20
ø25				Y-Q2-32	I-Q2-32	YS-Q2-32
ø32	FA-M1-32		SDB-M1-32			
ø40	FA-M1-40		SDB-M1-40	Y-Q2-40	I-Q2-40	YS-Q2-40

Pin

Applicable	YS connector	Y&I connector	SDB connector
Code	PIN-S	PIN-Y-P (with split pin / snap ring)	PIN-SDB-P (with snap ring)
Fig			
Tube I.D.		ø16 ø20~ø40	
ø16	PIN-M3-16-S	PIN-M3-12-2-P	PIN-M1-16-1-P
ø20	PIN-M3-20-S	PIN-M3-20-2-P	PIN-M3-20-1-P
ø25	PIN-Q2-32-S	PIN-Q2-32-2-P	
ø32			
ø40	PIN-Q2-40-S	PIN-Q2-40-2-P	PIN-M1-40-1-P

Order example of self-assembled

The tube I.D. ø16 of LB accessories, Y connector and pin.

No.	Order number	Qty
1	LB-M1-16x2	1
2	Y-M3-12	1
3	PIN-M3-12-2-P	1

* To order accessories/ connectors/ pin separately, please place orders separately according to the order codes in the above table.

Order example of factory assembled



△ Cylinders and accessories are distinguished by the symbol "+".

MCMA – Standard model no. + LB
CYLINDER ACCESSORIES

Cylinder & accessories weight





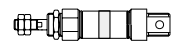





Cylinder weight

Unit: g

Model	Basic weight MCMA-11	Basic weight MCMA-11-N	Basic weight MCMA-11-A	Stroke 25 mm MCMA-11-*
Tube I.D.				
ø16	76	70	74	13
ø20	178	162	159	24
ø25	230	214	202	30
ø32	295	277	363	39
ø40	496	462	506	60

Accessories weight

Unit: g

Model	LB	FA/FB	SDB	Y	I	YS	Pin	Floating pin	Rod nut	Cover nut
Tube I.D.										
ø16	65	25	24	13	15	18	5	5	2	11
ø20	103	67	103	40	42	50	10	10	4	20
ø25	103	67	103	72	82	90	19	18	8	20
ø32	200	95	153	72	72	90	19	18	8	29
ø40	233	110	184	96	96	128	33	32	11	47

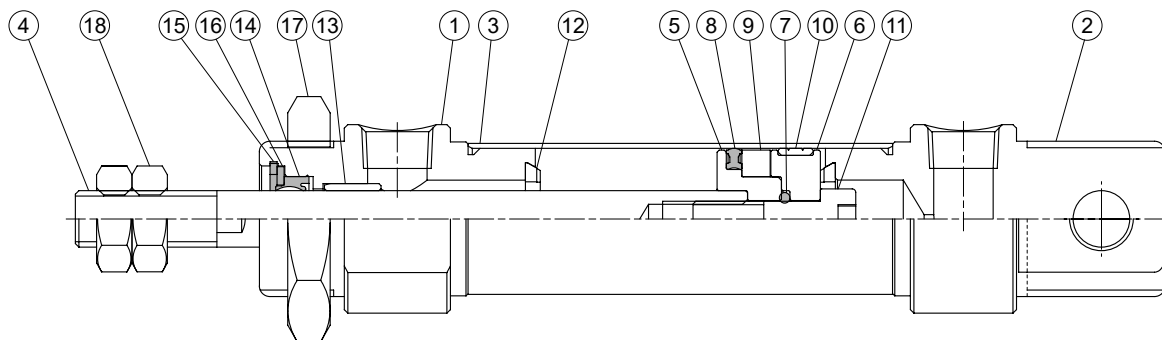

Material

No.	Tube I.D. Part name	16	20	25	32	40	Q'y		Component parts (inclusion)	
							11 type	21 type	11 type	21 type
1	Rod cover			Aluminum alloy			1	2	●	●
2	Head cover			Aluminum alloy			1	—	●	
3	Tube			Stainless steel			1	1		
4	Piston rod	*1		Carbon steel			1	1		
5	Piston-R			Aluminum alloy			1	1	●	●
6	Piston-H			Aluminum alloy			1	1	●	●
7	Piston gasket			NBR			1	1	●	●
8	Piston packing			NBR			1	1	●	●
9	Magnet ring			Magnet material			1	1	●	●
10	Wear ring			Resin			1	1	●	●
11	Piston bolt			SCM			1	—	●	
12	Cushion gasket			NBR			2	2	●	●
13	Rod bush			Bearing alloy			1	2	●	●
14	Rod packing *2			NBR			1	2	●	●
15	Snap ring			Spring steel			1	2	●	●
16	Washer			Carbon steel			1	2	●	●
17	Tie nut			Carbon steel			1	2	●	●
18	Rod front nut			Carbon steel			2	2	●	●

*1. Stainless steel

*2. Only the rod packing is repairable, please contact our sales if needed.

Order example of component parts

CP – MCMA – 2 – 16 – N – □

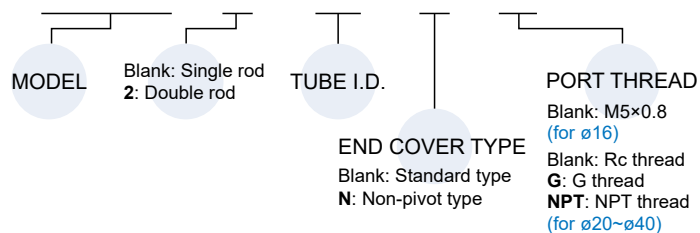

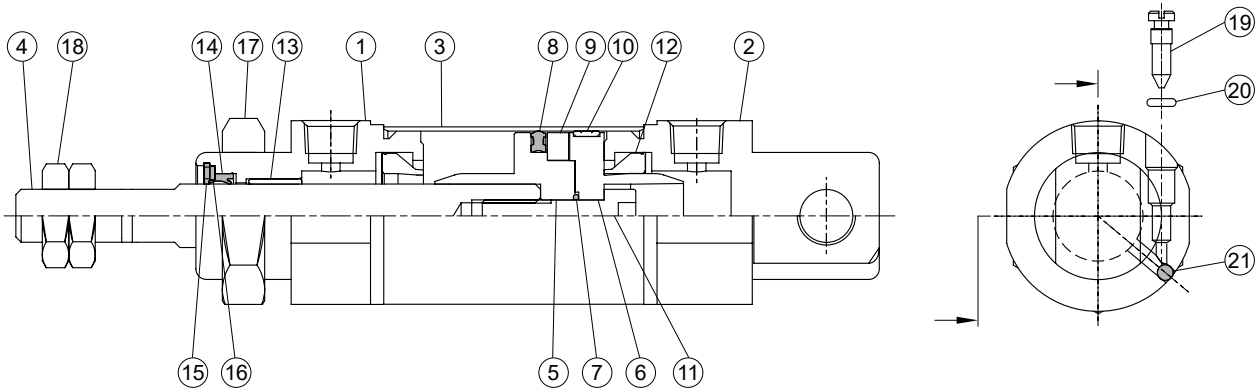

Material

No.	Tube I.D. Part name	16	20	25	32	40	Q'y		Component parts (inclusion)	
							11 type	21 type	11 type	21 type
1	Rod cover	Aluminum alloy				1	2	●	●	
2	Head cover	Aluminum alloy				1	—	●	●	
3	Tube	Stainless steel				1	1			
4	Piston rod	*1	Carbon steel				1	1		
5	Piston-R	Aluminum alloy				1	1	●	●	
6	Piston-H	Aluminum alloy				1	1	●	●	
7	Piston gasket	NBR				1	1	●	●	
8	Piston packing	NBR				1	1	●	●	
9	Magnet ring	Magnet material				1	1	●	●	
10	Wear ring	Resin				1	1	●	●	
11	Piston bolt	SCM				1	—	●		
12	Cushion packing	NBR				2	2	●	●	
13	Rod bush	Bearing alloy				1	2	●	●	
14	Rod packing *2	NBR				1	2	●	●	
15	Snap ring	Spring steel				1	2	●	●	
16	Washer	Carbon steel				1	2	●	●	
17	Tie nut	Carbon steel				1	2	●	●	
18	Rod front nut	Carbon steel				2	2	●	●	
19	Needle valve	Stainless steel		Carbon steel		2	2	●	●	
20	Needle valve packing	NBR				2	2	●	●	
21	Steel ball	Stainless steel				2	2	●	●	

*1. Stainless steel

*2. Only the rod packing is repairable, please contact our sales if needed.

Order example of component parts

CP — MCMA — 2 — 16 — A — N — □

MODEL

Blank: Single rod
2: Double rod

TUBE I.D.

END COVER TYPE
Blank: Standard type
N: Non-pivot type

A: Cushion air
(Adjustable)

PORT THREAD

Blank: M5×0.8
(for ø16)

Blank: Rc thread
G: G thread
NPT: NPT thread
(for ø20~ø40)

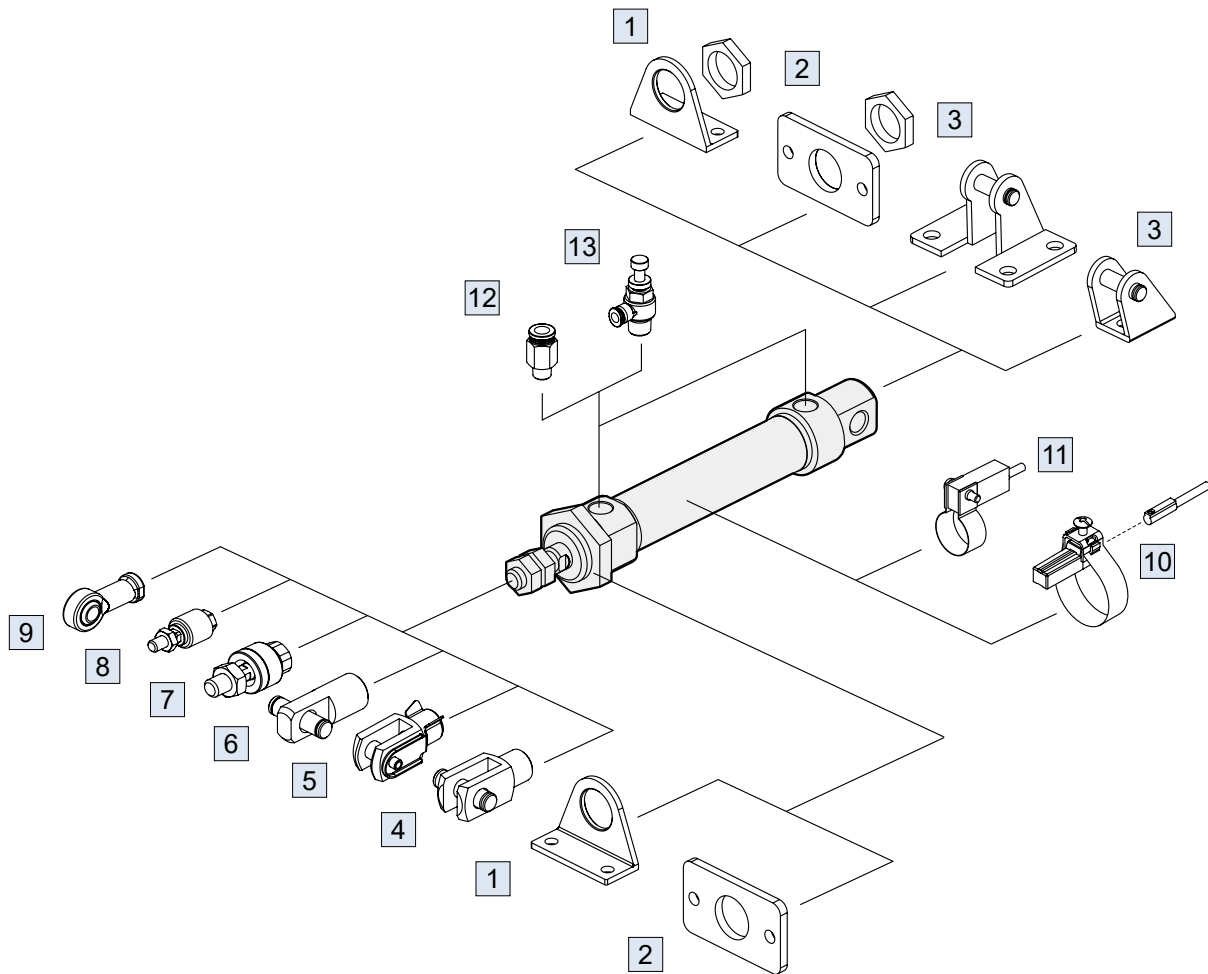

No.	Accessories	Material	Page link
1	Mounting accessories LB	Carbon steel	↗ , ↘
2	Mounting accessories FA/FB	Carbon steel	↗ , ↘
3	Mounting accessories SDB+PIN	Carbon steel	↗ , ↘ , ↙
4	Accessories Y+PIN	Carbon steel	↗
5	Accessories YS (Y+Floating pin)	Carbon steel	↗
6	Accessories I+PIN	Carbon steel	↗

No.	Accessories	Material	Page link
7	Floating joint MFC	Carbon steel	↗
8	Floating joint MFCS	Carbon steel	↗
9	Female rod ends PHS	Carbon steel	↗
10	Sensor switch R*C+BKC-1	-	↗
11	Sensor switch RCM+BM**	-	↗
12	Fitting PC (PISCO)	-	↗
13	Speed controller JSC (PISCO)	-	↗

MINIATURE CYLINDER

11

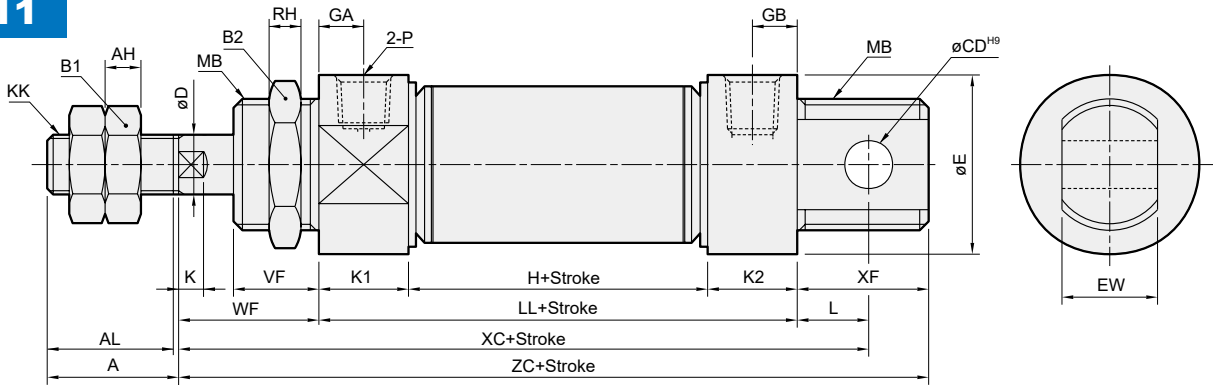

21

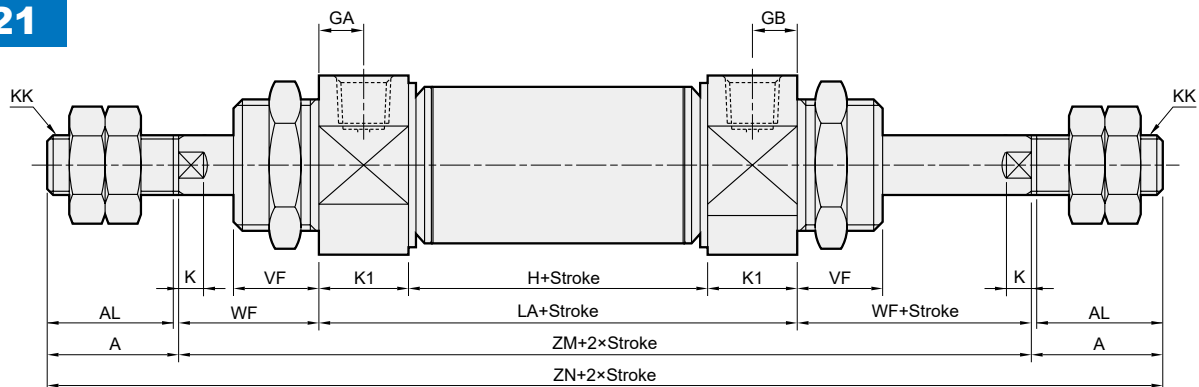

27

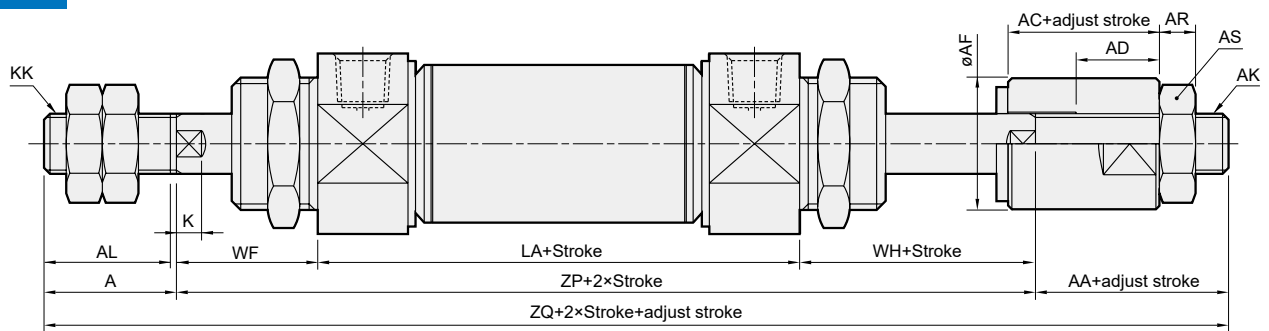

Code Tube I.D.	A	AA	AC	AD	AF	AH	AL	AR	AS	AK	B1	B2	CD	D	E	EW	GA	GB	H	K	KK
16	16	16	13	7.5	12	5	14	4	8	M5×0.8	10	22	6	6	19.7	12 ^{-0.05 -0.4}	5	5	34	4	M6×1.0
20	20	19	15	9.5	16	5	17.5	5	13	M8×1.25	13	30	8	8	26.7	16 ^{-0.05 -0.4}	7.5	7.5	40	3.5	M8×1.25
25	22	19	15	9.5	16	6	19.5	5	13	M8×1.25	17	30	8	10	29.7	16 ^{-0.05 -0.4}	7.5	7.5	40	5	M10×1.25
32	22	18	12	7	20	6	19.5	6	17	M10×1.25	17	32	10	12	36	16 ^{-0.05 -0.4}	7.5	10.5	37	8	M10×1.25
40	30	18	12	7	30	7	27	7	19	M12×1.25	19	41	12	14	45	20 ^{-0.05 -0.4}	7.5	10.5	42	7	M12×1.25

Code Tube I.D.	K1	K2	L	LA	LL	MB	P	RH	VF	WF	WH	XC	XF	ZC	ZM	ZN	ZP	ZQ
16	10	10	9	54	54	M16×1.5	M5×0.8	6	12	22	19.5	85	16	92	98	130	95.5	127.5
20	15	15	12	70	70	M22×1.5	Rc1/8	6	12	18	19.5	100	21	109	106	146	107.5	146.5
25	15	15	12	70	70	M22×1.5	Rc1/8	6	15	27	22.5	109	21	118	124	168	119.5	160.5
32	15	18	14	67	70	M24×2.0	Rc1/8	8	18	30	24	114	24	124	127	171	121	161
40	15	18	16	72	75	M30×2.0	Rc1/8	8	17	27	24	118	28	130	126	186	123	171

MINIATURE CYLINDER

N

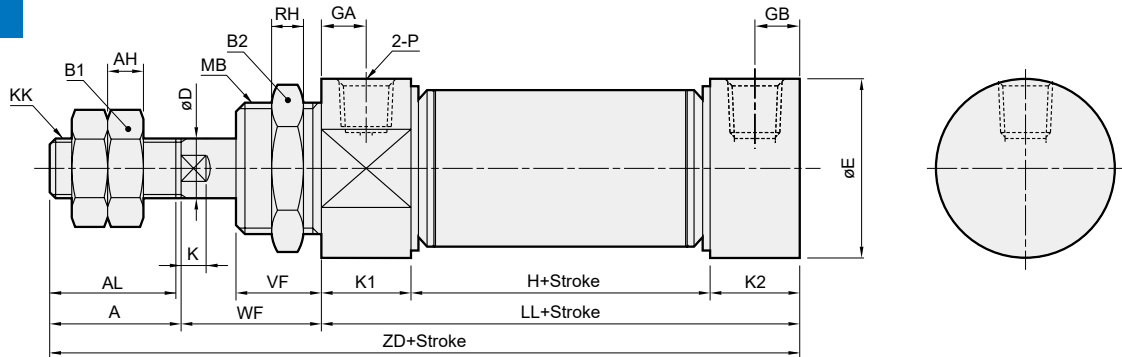

Code Tube I.D.	A	AH	AL	B1	B2	D	E	GA	GB	H	K	KK	K1	K2	LL	MB	P	RH	VF	WF	ZD
16	16	5	14	10	22	6	19.7	5	5	34	4	M6×1.0	10	10	54	M16×1.5	M5×0.8	6	12	22	92
20	20	5	17.5	13	30	8	26.7	7.5	7.5	40	3.5	M8×1.25	15	15	70	M22×1.5	Rc1/8	6	12	18	108
25	22	6	19.5	17	30	10	29.7	7.5	7.5	40	5	M10×1.25	15	15	70	M22×1.5	Rc1/8	6	15	27	119
32	22	6	19.5	17	32	12	36	7.5	10.5	37	8	M10×1.25	15	18	70	M24×2.0	Rc1/8	8	18	30	122
40	30	7	27	19	41	14	45	7.5	10.5	42	7	M12×1.25	15	18	75	M30×2.0	Rc1/8	8	17	27	132

■ Mounting accessories

LB

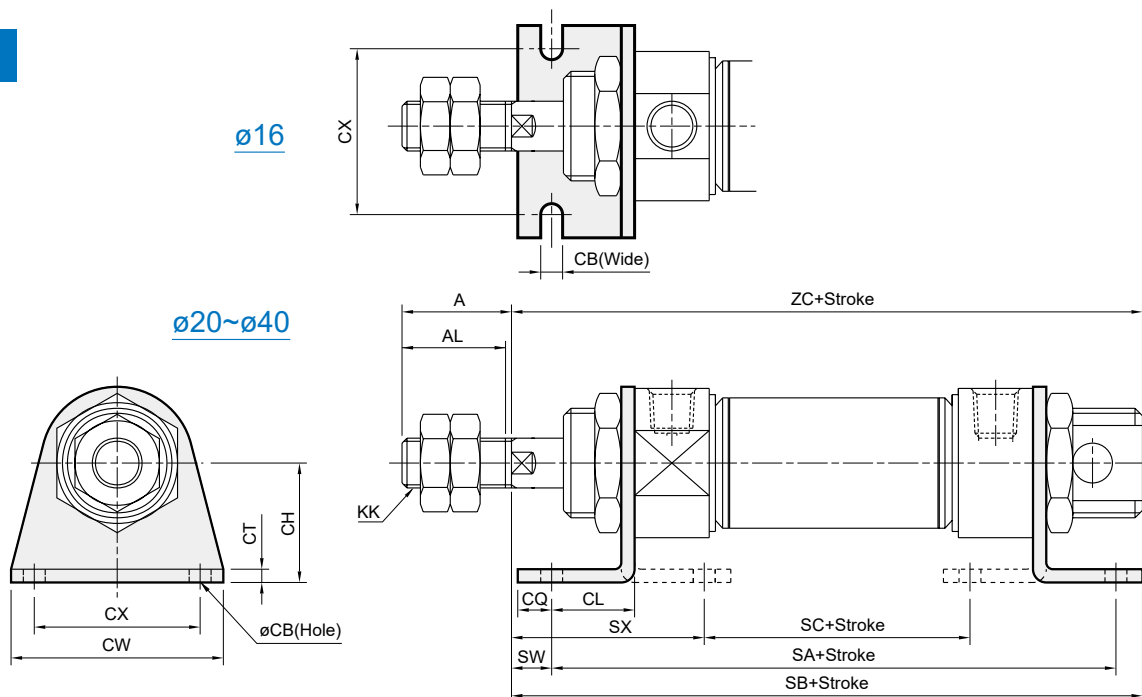

Code Tube I.D.	A	AL	CB	CH	CL	CQ	CT	CW	CX	KK	SA	SB	SC	SW	SX	ZC
16	16	14	5.5	20	13	6	3.2	44	32	M6×1.0	80	95	34.4	9	31.8	92
20	20	17.5	6.6	25	15	8	3.2	54	40	M8×1.25	100	111	46.4	3	29.8	109
25	22	19.5	6.6	25	15	8	3.2	54	40	M10×1.25	100	120	46.4	12	38.8	118
32	22	19.5	6.6	32	25	8	4	59	45	M10×1.25	120	133	28	5	51	124
40	30	27	6.6	36	25	8	4	64	50	M12×1.25	125	135	33	2	48	130

FA / FB

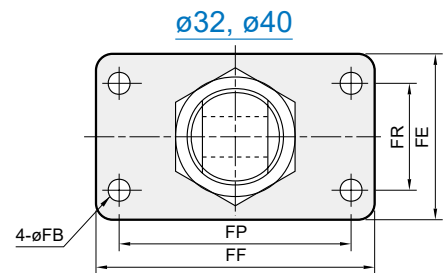
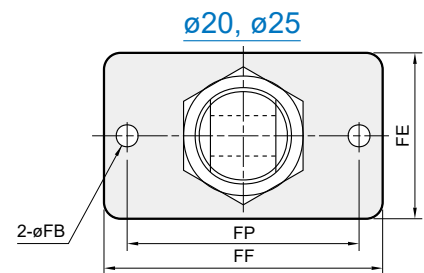
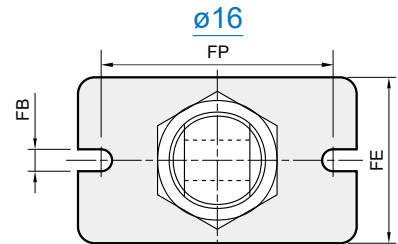
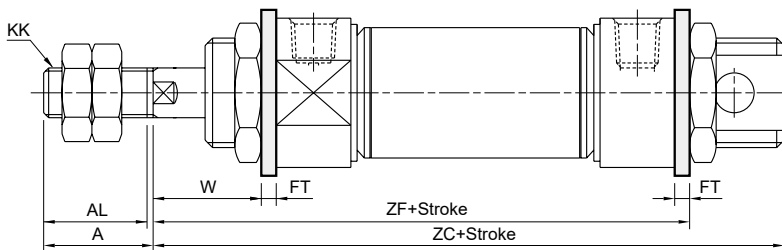

Code Tube I.D.	A	AL	FB	FE	FF	FP	FR	FT	KK	W	ZC	ZF
16	16	14	5.5	26	52	40	—	3.2	M6×1.0	18.8	92	79.2
20	20	17.5	6.6	38	64	50	—	4.5	M8×1.25	13.5	109	92.5
25	22	19.5	6.6	38	64	50	—	4.5	M10×1.25	22.5	118	101.5
32	22	19.5	6.6	47	72	58	33	4.5	M10×1.25	25.5	124	104.5
40	30	27	6.6	50	84	70	36	4.5	M12×1.25	22.5	130	105.5

SDB

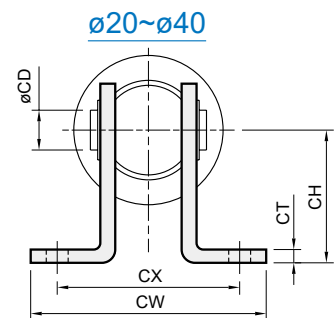
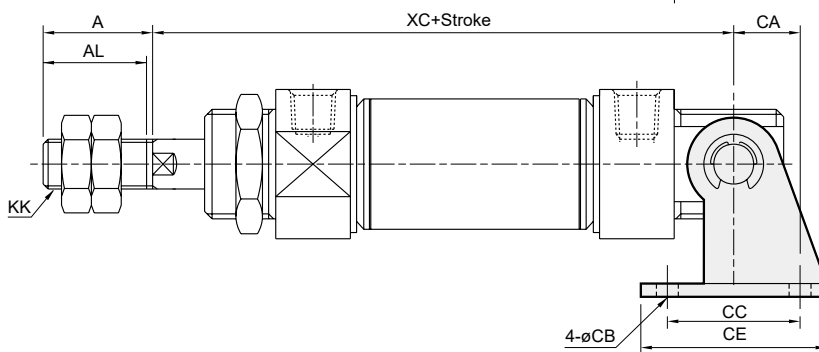
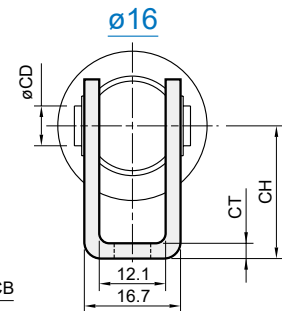
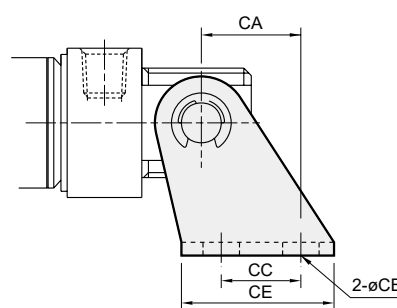

Code Tube I.D.	A	AL	CA	CB	CC	CD	CE	CH	CT	CW	CX	KK	XC
16	16	14	15	5.5	12	6	23	20	2.3	—	—	M6×1.0	85
20	20	17.5	16	6.6	32	8	48	32	3.2	67	51	M8×1.25	100
25	22	19.5	16	6.6	32	8	48	32	3.2	67	51	M10×1.25	109
32	22	19.5	18	6.6	36	10	52	36	4	67	51	M10×1.25	114
40	30	27	20	6.6	40	12	56	40	4	69	53	M12×1.25	118

MINIATURE CYLINDER

13

15

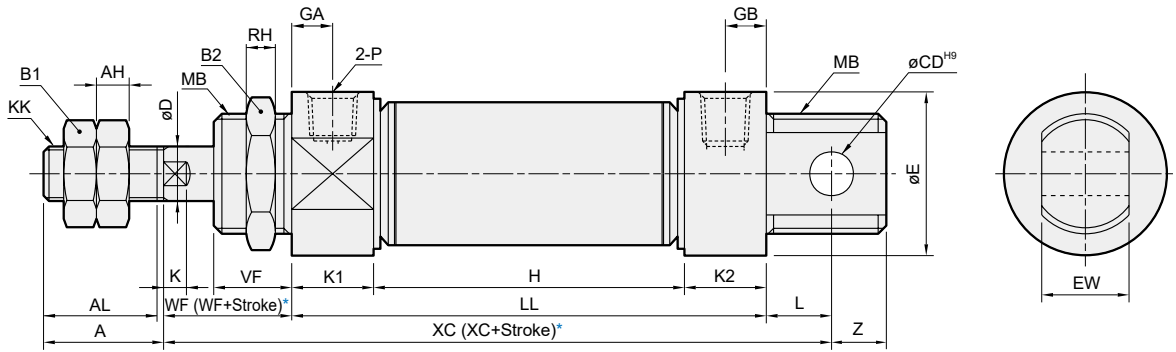

* () Dimension for 13 type.

Code Tube I.D.	A	AH	AL	B1	B2	CD	D	E	EW	GA	GB	K	KK	K1	K2	L	MB	P	RH	VF	WF	Z
16	16	5	14	10	22	6	6	19.7	12 ^{-0.05 -0.4}	5	5	4	M6×1.0	10	10	9	M16×1.5	M5×0.8	6	12	22	7
20	20	5	17.5	13	30	8	8	26.7	16 ^{-0.05 -0.4}	7.5	7.5	3.5	M8×1.25	15	15	12	M22×1.5	Rc1/8	6	12	18	9
25	22	6	19.5	17	30	8	10	29.7	16 ^{-0.05 -0.4}	7.5	7.5	5	M10×1.25	15	15	12	M22×1.5	Rc1/8	6	15	27	9
32	22	6	19.5	17	32	10	12	36	16 ^{-0.05 -0.4}	7.5	10.5	8	M10×1.25	15	18	14	M24×2.0	Rc1/8	8	18	30	10

Code Stroke Tube I.D.	H							LL							XC						
	15	25	50	75	100	125	150	15	25	50	75	100	125	150	15	25	50	75	100	125	150
16	64	74	114	154	194	—	—	84	94	134	174	214	—	—	115	125	165	205	245	—	—
20	80	90	140	190	240	290	340	110	120	170	220	270	320	370	140	150	200	250	300	350	400
25	80	90	140	190	240	290	340	110	120	170	220	270	320	370	149	159	209	259	309	359	409
32	77	87	137	187	237	287	337	110	120	170	220	270	320	370	154	164	214	264	314	364	414

23

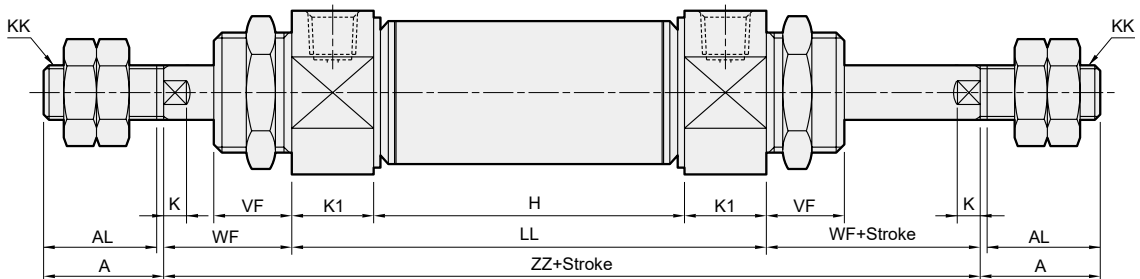

Code Stroke Tube I.D.	H							LL							ZZ						
	15	25	50	75	100	125	150	15	25	50	75	100	125	150	15	25	50	75	100	125	150
16	64	74	114	154	194	—	—	84	94	134	174	214	—	—	125	135	175	215	255	—	—
20	80	90	140	190	240	290	340	110	120	170	220	270	320	370	146	156	206	256	306	356	406
25	80	90	140	190	240	290	340	110	120	170	220	270	320	370	164	174	224	274	324	374	424
32	77	87	137	187	237	287	337	107	117	167	217	267	317	367	167	177	227	277	327	377	427

LB

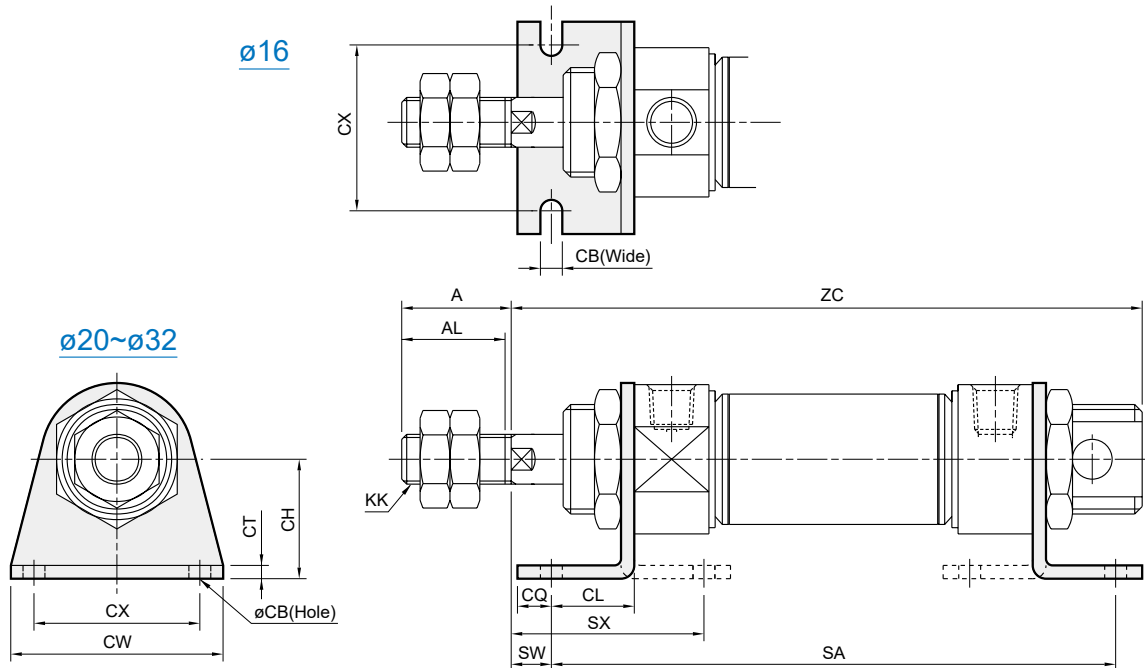

Code Tube I.D.	A	AL	CB	CH	CL	CQ	CT	CW	CX	KK	SW	SX
16	16	14	5.5	20	13	6	3.2	44	32	M6×1.0	9	31.8
20	20	17.5	6.6	25	15	8	3.2	54	40	M8×1.25	3	29.8
25	22	19.5	6.6	25	15	8	3.2	54	40	M10×1.25	12	38.8
32	22	19.5	6.6	32	25	8	4	59	45	M10×1.25	5	51

Code Stroke Tube I.D.	SA							ZC						
	15	25	50	75	100	125	150	15	25	50	75	100	125	150
16	110	120	160	200	240	—	—	121	131	171	211	251	—	—
20	140	150	200	250	300	350	400	146	156	206	256	306	356	406
25	140	150	200	250	300	350	400	155	165	215	265	315	365	415
32	160	170	220	270	320	370	420	162	172	222	272	322	372	422

Installation of sensor switch

Sensor switch: R*C
Band: BKC-1

Code Tube I.D.	A	B	D	E
16	24.5	34.5	13.5	27
20	26.5	40	13.5	27
25	29	44	13.5	27
32	33	51	13.5	27
40	37	59.5	13.5	27

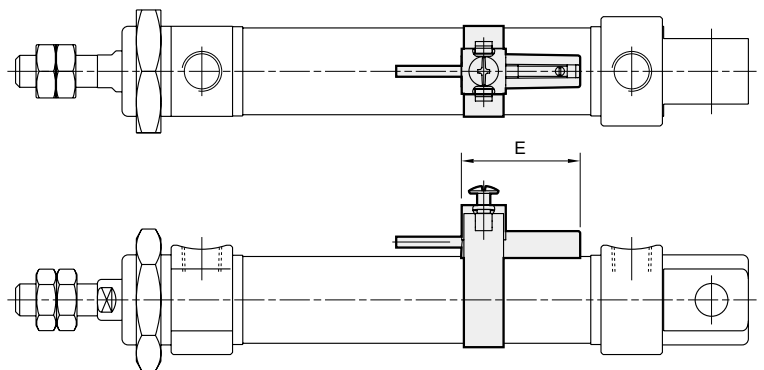
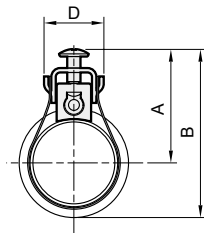

Sensor switch: RCM
Band: BM**

Code Tube I.D.	A	B	C	D	E
16	20	30	10	16	28
20	22	36	10	16	28
25	25	40	10	16	28
32	28	46	10	16	28
40	32	55	10	16	28

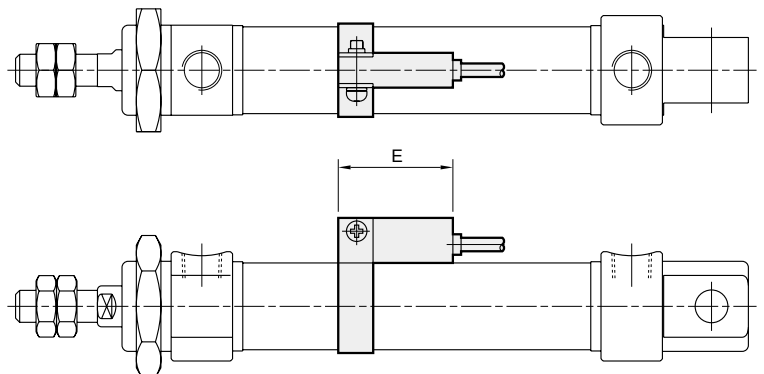
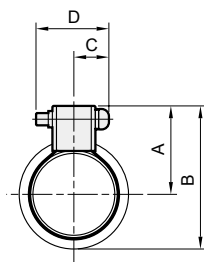

MINIATURE CYLINDER

FA / FB

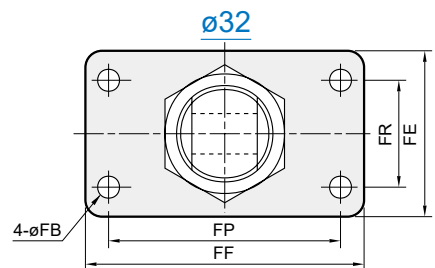
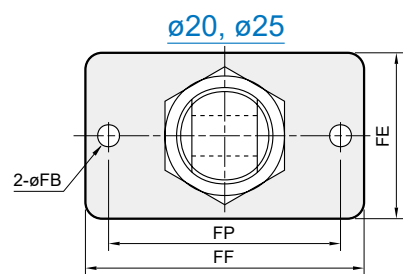
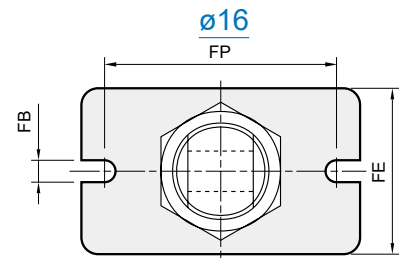
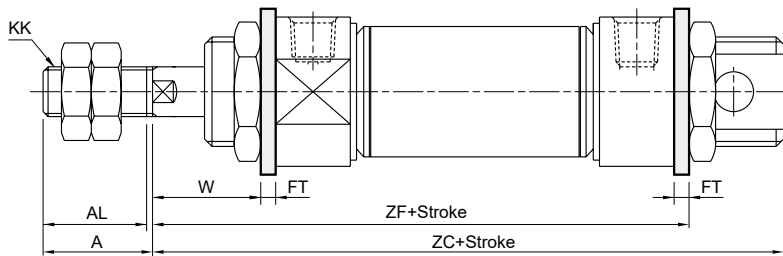

Code Tube I.D.	A	AL	FB	FE	FF	FP	FR	FT	KK	W
16	16	14	5.5	26	52	40	—	3.2	M6×1.0	18.8
20	20	17.5	6.6	38	64	50	—	4.5	M8×1.25	13.5
25	22	19.5	6.6	38	64	50	—	4.5	M10×1.25	22.5
32	22	19.5	6.6	47	72	58	33	4.5	M10×1.25	25.5

Code Stroke Tube I.D.	ZC							ZF						
	15	25	50	75	100	125	150	15	25	50	75	100	125	150
16	121	131	171	211	251	—	—	109.2	119.2	159.2	199.2	239.2	—	—
20	146	156	206	256	306	356	406	132.5	142.5	192.5	242.5	292.5	342.5	392.5
25	155	165	215	265	315	365	415	141.5	151.5	201.5	251.5	301.5	351.5	401.5
32	162	172	222	272	322	372	422	144.5	154.5	204.5	254.5	304.5	354.5	404.5

SDB

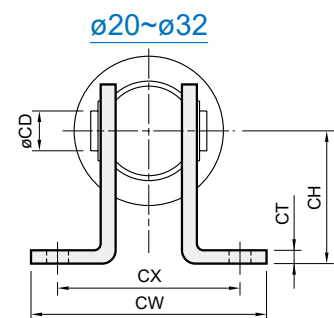
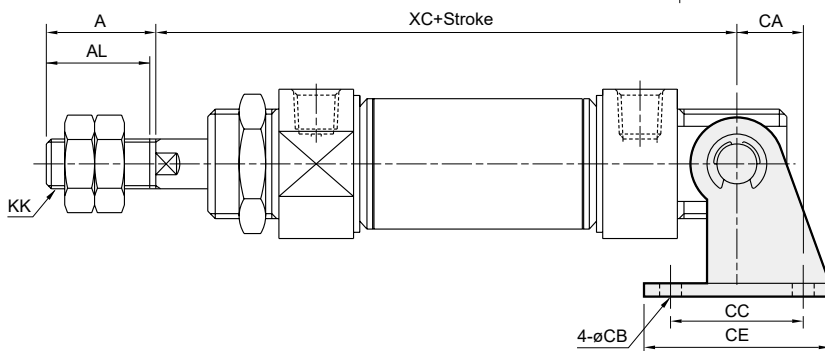
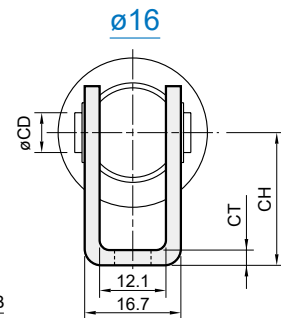
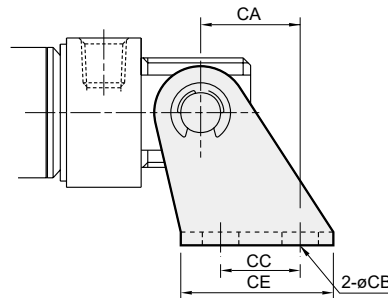

Code Tube I.D.	A	AL	CA	CB	CC	CD	CE	CH	CT	CW	CX	KK
16	16	14	15	5.5	12	6	23	20	2.3	—	—	M6×1.0
20	20	17.5	16	6.6	32	8	48	32	3.2	67	51	M8×1.25
25	22	19.5	16	6.6	32	8	48	32	3.2	67	51	M10×1.25
32	22	19.5	18	6.6	36	10	52	36	4	67	51	M10×1.25

Code Stroke Tube I.D.	XC						
	15	25	50	75	100	125	150
16	107	117	157	197	257	—	—
20	139	149	199	249	299	349	399
25	141	151	172	222	272	322	372
32	142	152	173	223	273	323	373

MINIATURE CYLINDER

mindman

Y connector

$\varnothing 8 \sim \varnothing 16$

Not suitable for (S) floating pin

$\varnothing 16^*$

For (S) floating pin

$\varnothing 20 \sim \varnothing 40$

I connector

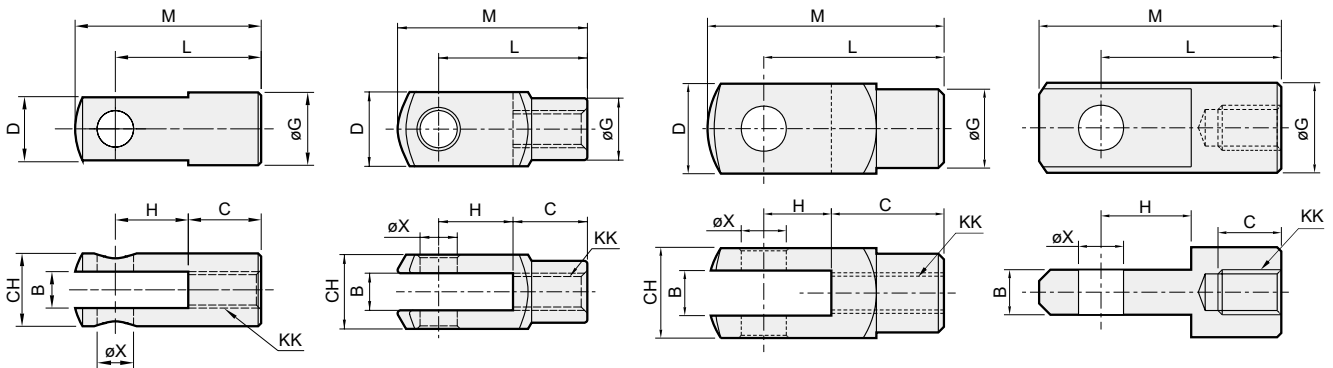

Code Tube I.D.	B		C		CH		D		G		H		L		M		X
	Y	I	Y	I	Y	I	Y	I	Y	I	Y	I	Y	I	Y	I	
8,10	4 ^{+0.4} _{+0.1}	—	8	—	8	—	8	—	—	—	8	—	16	—	20.75	—	4 ^{+0.1} _{+0.01}
12,16	6 ^{+0.4} _{+0.1}	6 ^{-0.2} _{-0.3}	12	8	12	—	—	—	12	12	12	10	24	21	31	28	6 ^{+0.1} _{+0.01}
16*	6 ^{+0.4} _{+0.1}	—	12	—	12	—	12	—	10	—	12	—	24	—	31	—	6 ^{+0.03} ₀
20	8 ^{+0.5} _{+0.15}	8 ^{-0.1} _{-0.2}	16	14	16	—	16	—	14	16	16	12	32	32	42	42	8 ^{+0.1} _{+0.01}
25,32	10 ^{+0.5} _{+0.15}	10 ^{-0.1} _{-0.2}	20	17	19	—	19	—	18	20	20	15	40	40	52	52	10 ^{+0.1} _{+0.01}
40	12 ^{+0.5} _{+0.15}	12 ^{-0.1} _{-0.2}	24	21	22	—	22	—	20	24	24	18	48	48	62	62	12 ^{+0.1} _{+0.01}

Code Tube I.D.	KK (MCMA)		KK (MCFI)	
	Y	I	Y	I
8,10	M4×0.7	—	M4×0.7	—
12,16,16*	M6×1.0			
20	M8×1.25			
25	M10×1.25			
32	M10×1.25	—	M10×1.5	—
40	M12×1.25	—	M12×1.75	—

PIN

S $\varnothing 16^* \sim \varnothing 40$

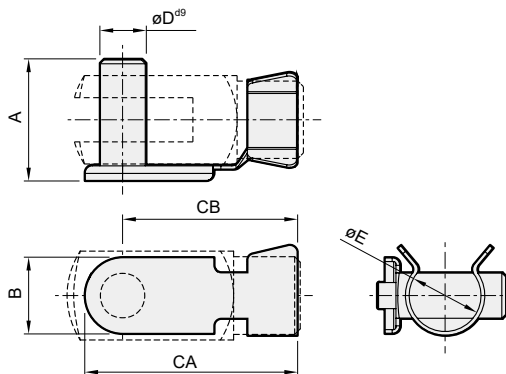

for floating pin

Code Tube I.D.	A	B	CA	CB	D ^{d9}	E
16*	16	10	28	23	ø6 ^{-0.03} _{-0.06}	9.5
20	22	12	37	31	ø8 ^{-0.04} _{-0.08}	13.5
25,32	26	14	45	38	ø10 ^{-0.04} _{-0.08}	17
40	31	16	54	46	ø12 ^{-0.05} _{-0.09}	19

P $\varnothing 8 \sim \varnothing 16$

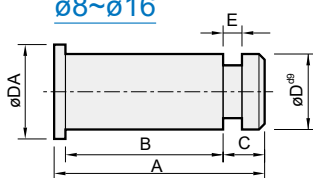

$\varnothing 20 \sim \varnothing 40$

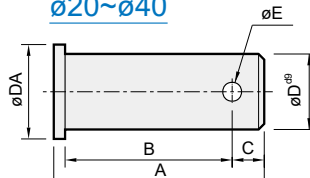

for Y & I connector

Code Tube I.D.	A	B	C	D ^{d9}	DA	E	Split pin
8,10	12	8.5	2	4 ^{-0.03} _{-0.06}	8	0.7	E3
12,16	18.5	15	2	6 ^{-0.03} _{-0.06}	10	0.7	E4
20	24.5	20.5	2.5	8 ^{-0.04} _{-0.08}	12	ø2.5	2.5×16L
25,32	30	25	3.5	10 ^{-0.04} _{-0.08}	14	ø3.2	3.2×20L
40	37	30	5	12 ^{-0.05} _{-0.09}	16	ø3.2	3.2×20L

P $\varnothing 8 \sim \varnothing 40$

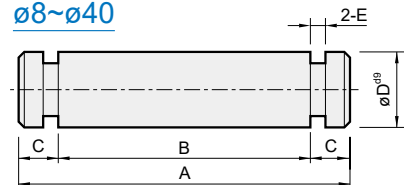

for SDB

Code Tube I.D.	A	B	C	D ^{d9}	E	Split pin
8,10	18	14	2	4 ^{-0.03} _{-0.06}	0.7	E3.2
12	23.5	19.5	2	6 ^{-0.03} _{-0.06}	0.7	E5
16	21	17	2	6 ^{-0.03} _{-0.06}	0.7	E5
20,25	30	25	2.5	8 ^{-0.04} _{-0.08}	0.9	E7
32	33	27	3	10 ^{-0.04} _{-0.08}	0.9	E9
40	37	31	3	12 ^{-0.05} _{-0.09}	0.9	E9