

MCRQ2-S series

ROTARY ACTUATOR



Moment of inertia



Technical data



Caution for safety
(Read before installing)



Order example

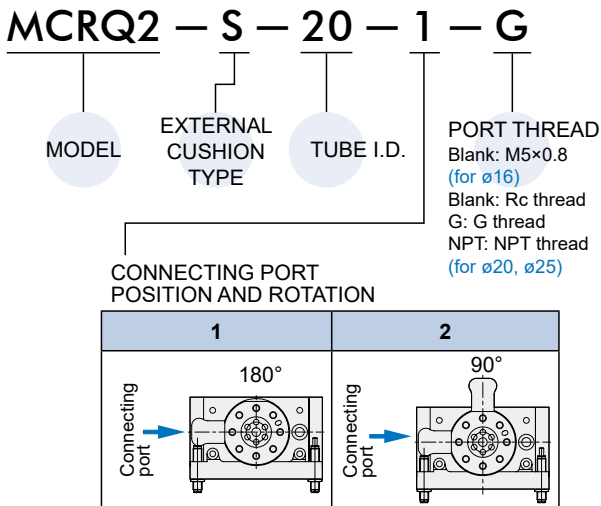

Features

- **4 to 10 times more allowable kinetic energy** (compared with internal shock absorber type)
- **Total length shortened**
Longitudinal mounting space is reduced because there is no protrusion from adjustment bolts or internal shock absorbers.

Specification

Model	MCRQ2-S		
Acting type	Double acting		
Tube I.D. (mm)	16	20	25
Port size	M5×0.8	Rc1/8	
Rotation	90°, 180°		
Medium	Air (Non-lube)		
Max. operating pressure	1 MPa (*1)		
Min. operating pressure	0.2 MPa		
Ambient temperature	0~+60°C (No freezing)		
Allowable kinetic energy (J)	0.231	1.21	1.82
Rotation time adjustment range (s/90°)	0.2~1.0 (*2)		
Cushion	Shock absorber		
Shock absorber type	MDSC-0806-3N	MDSC-1008-3N	MDSC-1412-3N
Angle adjustment range	Each rotation end ± 3°		
Weight (kg)	90°	0.67	1.55
	180°	0.64	1.48
Sensor switch	RDC(V), RQC(V)		

*1. The maximum operating pressure of the actuator is restricted by the maximum allowable thrust of the shock absorber.

*2. For stable operation the time required for the rotary table to reach the rotation end after deceleration differs depending on the operating conditions (inertial moment of the load, rotation speed, and operating pressure), however, approximately 0.2 to 2 seconds are required.

Notice for shock absorber

- The threaded orifices shown below are not connecting ports. Never remove the plugs as this will cause malfunction.
- Never rotate the bottom screw of the shock absorber. (It is not an adjustment screw.) This may cause oil leakage.

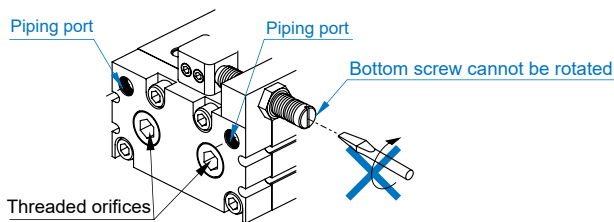

Range of shock absorber operates

Model	Adjustment angle per rotation of angle adjustment screw	Range of angle the shock absorber operates (single side)
MCRQ2-S-16	1.5°	12°
MCRQ2-S-20	1.1°	9°
MCRQ2-S-25	1.3°	11°

Rotating direction and angle

- When the port 1 is pressurized, the flange rotates in clockwise (CW) direction.
- When the port 2 is pressurized, the flange rotates in counter-clockwise (CCW) direction.

The rotating angle range can be adjust by the method shown as right figure.

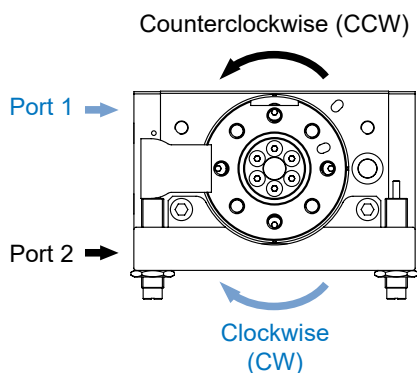

MCRQ2-S-* -1 180°

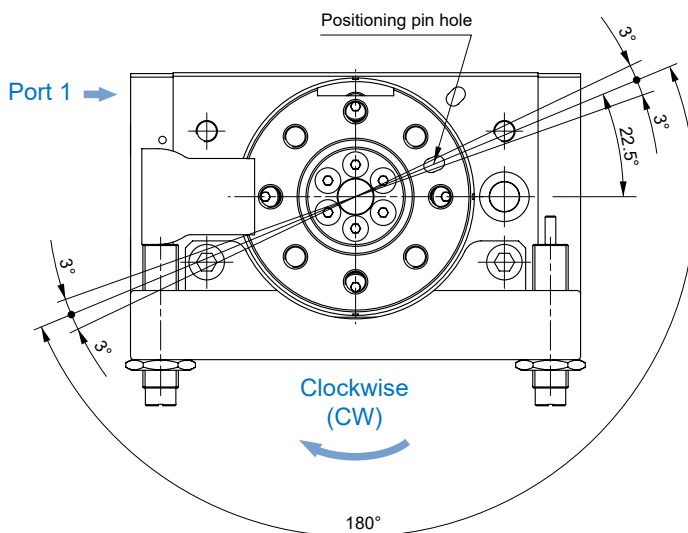

Minimum rotating range 174°
Maximum rotating range 186°

MCRQ2-S-* -2 90°

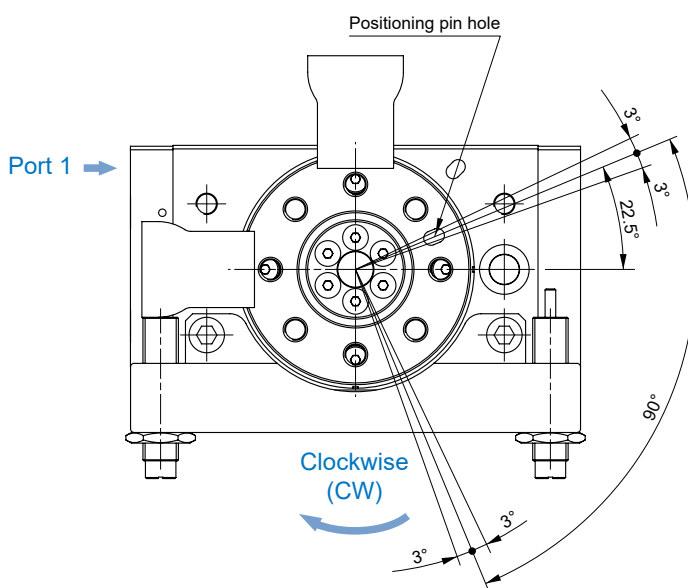

Minimum rotating range 84°
Maximum rotating range 96°

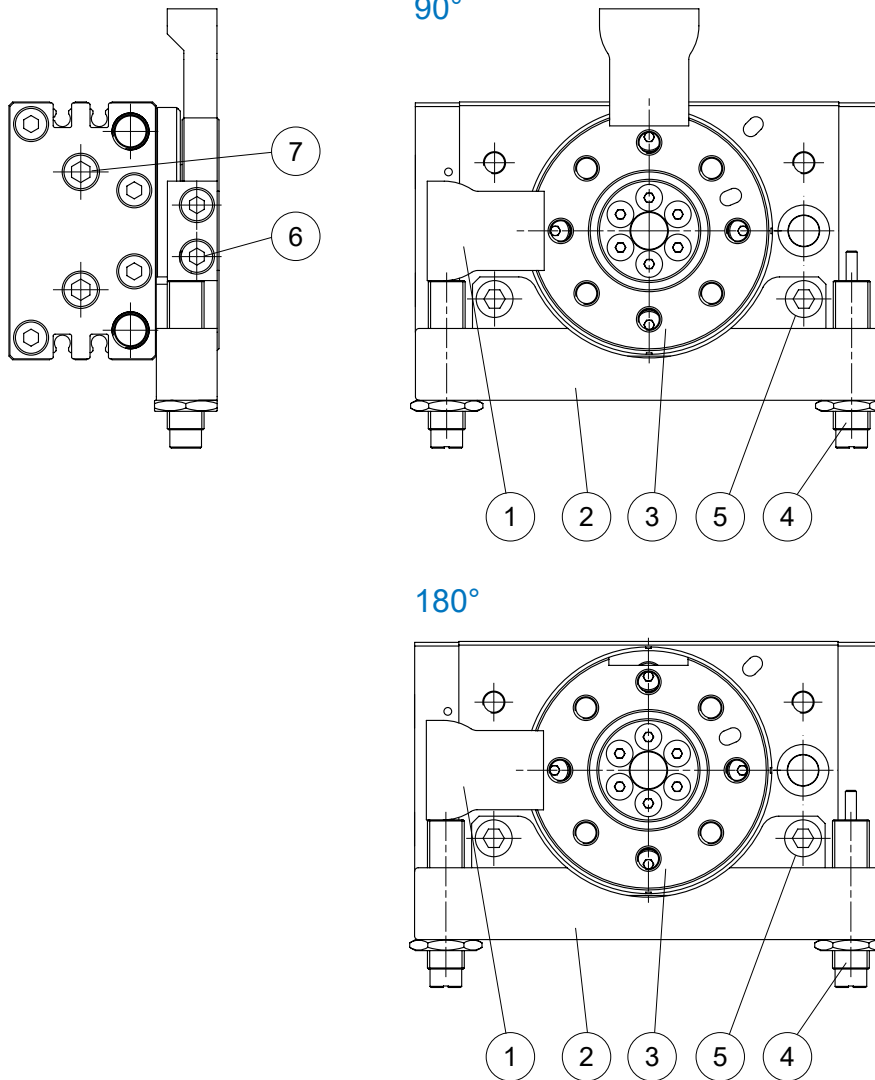

Material

No.	Part name	Material	Rotation & Q'y	
			90°	180°
1	Fixing plate	Carbon steel	2	1
2	Cushion mount	Aluminum alloy	1	1
3	Flange table	Aluminum alloy	1	1
4	Shock absorber	—	2	2
5	Bolt	Stainless steel	2	2
6	Bolt	Stainless steel	4	2
7	Plug	Stainless steel	2	2

MCRQ2-S Dimensions $\phi 16 \sim \phi 25$



ROTARY ACTUATOR

mindman

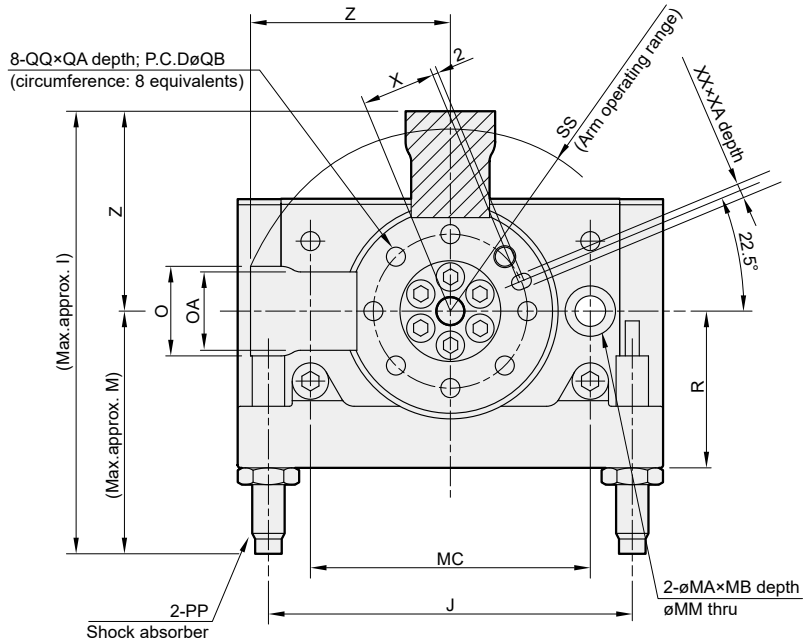
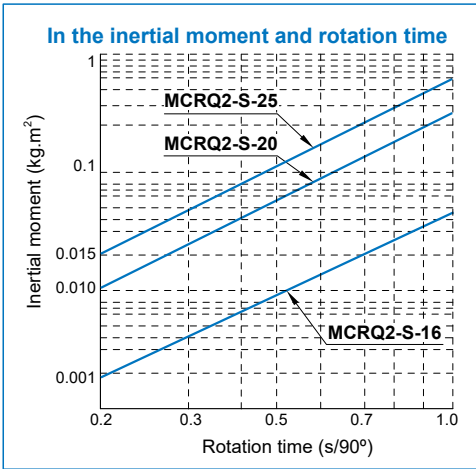

Code Tubr I.D.	PP
16	MDSC-0806-3N
20	MDSC-1008-3N
25	MDSC-1412-3N

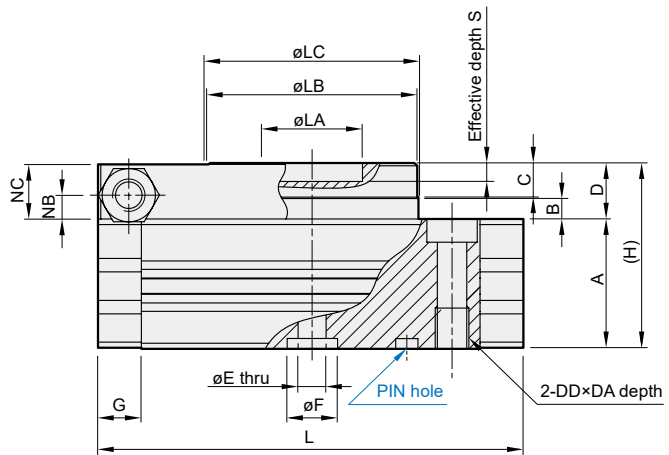
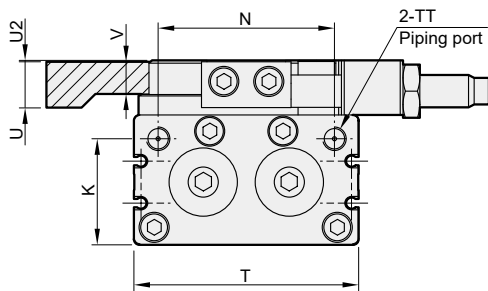

PIN hole size

Code Tubr I.D.	HH	ZX
16	3H9×3.5	19
20	4H9×4.5	28
25	5H9×5.5	33

Code Tubr I.D.	A	B	C	D	DA	DD	E	F	G	H	I	J	K	L	LA	LB	LC	M	MA	MB	MC
16	34	4.5	8	13	12	M8×1.25	6	15H9	9.5	47	92.8	80.6	29	92	20H9	45h9	46h9	48.5	11	6.5	60
20	40	6.5	10	17	15	M10×1.5	10	22H9	12	57	119.3	110	33	127	32H9	65h9	67h9	59	14	8.5	84
25	46	7.5	12	20	18	M12×1.75	13	26H9	15.5	66	154.8	130	37.5	152	35H9	75h9	77h9	83.3	18	10.5	100

Code Tubr I.D.	MM	N	NB	NC	O	OA	QA	QB	QQ	R	S	SS	T	TT	U	U2	V	X	XA	XX	Z
16	6.8	37	5.5	12.5	20	15.6	8	32	M5×0.8	33	4	45.4	50	M5×0.8	11.5	0.3	7.5	15	3.5	3H9	44.3
20	8.6	54	8	16.5	27	21.5	10	48	M6×1	46	4.5	61.8	70	Rc1/8	13.5	0.5	9	23	4.5	4H9	60.3
25	10.5	63	8.5	19.5	32	28	12	55	M8×1.25	54.5	5	73.3	80	Rc1/8	18	0.5	11	26.5	5.5	5H9	71.5