



Moment of inertia



Technical data



Caution for safety  
(Read before installing)



### Symbol

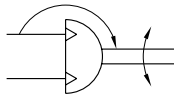

### Order example

**MCRQ2 – 20R – □ – □**

MODEL      TUBE I.D.      PORT LOCATION (\*)      PORT THREAD

ANGLE ADJUSTER  
A: With adjusting bolt  
R: With shock absorber  
\* ø12 without shock absorber.

Blank: End port  
E: Front port

Blank: M5×0.8 (for ø12, ø16)  
Blank: Rc thread  
G: G thread  
NPT: NPT thread (for ø20~ø40)

\* ø12 only option.  
\* Port location cannot be changed after delivery.

### Features

- Centering boss and locating hole for accurate positioning.
- Operating range of table is 0°~190° by angle adjusting screw.
- Compact design using double rack and single pinion.
- Hollow shaft standard for wiring and piping.
- Possible to fit shock absorbers as stops.
- Ease of mounting with integral table.
- Magnetic as standard.

### Specification

Model	MCRQ2						
Acting type	Double acting						
Tube I.D. (mm)	12	16	20	25	32	40	
Port size	M5×0.8		Rc1/8				
Medium	Air						
Max. operating pressure	adjusting bolt	0.7MPa	1 MPa				
	shock absorber	—	0.6 MPa (*1)				
Min. operating pressure	0.1 MPa (*2)						
Ambient temperature	0~+60°C (No freezing)						
Cushion	adjusting bolt	Rubber bumper					
	shock absorber	—	Shock absorber (*3)				
Angle adjustment range	0° to 190°(max.) (*4)						
Sensor switch	RDC(V), RQC(V) 						
Weight (kg)	adjusting bolt	0.25	0.60	1.24	2.10	4.18	7.67
	shock absorber	—	0.61	1.31	2.12	4.19	7.72
Minimum rotation that will not allow decrease of energy absorption ability	—	72°	58°	69°	77°	82°	

\*1. The maximum operating pressure of the actuator is restricted by the maximum allowable thrust of the shock absorber.

\*2. No-load conditions.

\*3. The shock absorber is expendable. Replace when damping performance decrease.

\*4. Be careful if the rotation angle of a type with internal shock absorber is set below the value in the table below, the piston stroke will be smaller than the shock absorber's effective stroke, resulting in decreased energy absorption ability.

### Allowable kinetic energy and rotation time adjustment range

Model	Allowable kinetic energy (J)		Rotation time adjustment range for stable operation(s/90°)	
	Adjustment bolt	Internal shock adsorber	Adjustment bolt	Internal shock adsorber
MCRQ2-12	0.006	—	0.2 to 1.0	—
MCRQ2-16	0.007	0.039		0.2 to 0.7
MCRQ2-20	0.048	0.116		
MCRQ2-25	0.081	0.294	0.2 to 2.0	0.2 to 1.0
MCRQ2-32	0.32	1.6		
MCRQ2-40	0.53	2.9		

\* Be careful if a type with internal absorber is used below the minimum speed, the energy absorption ability will decrease drastically.

### Torque diagram

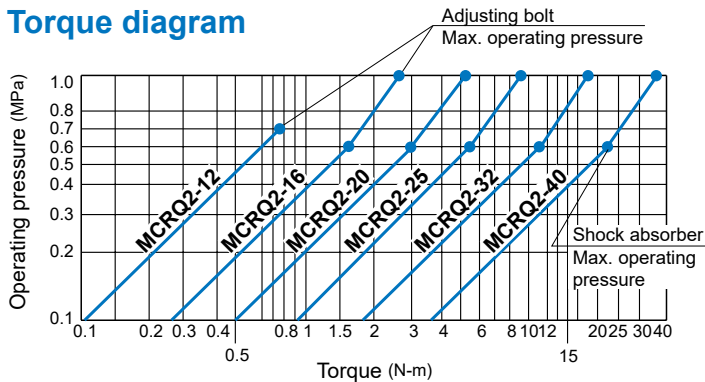

### Installation guide of shock absorber

- ❶ Install 3 nuts on the shock absorber as the picture shown.
- ❷ Bind the A nut and B nut together via tightening them with different rotating direction.
- ❸ Hold B nut and rotate C nut to bind the plate and C nut together.
- ❹ Unbind the A nut and B nut. The installation is complete.
- ❺ For the tightening torque of the fixed nut of the shock absorber, please refer to the table below.

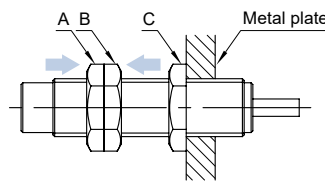

Tube I.D.	Max. tightening torque (N.m)
16	1.67
20	3.14
25	10.8
32	23.5
40	62.8

### Theoretic force

Unit: N·m

Model		MCRQ2					
Tube I.D.		12	16	20	25	32	40
Operating pressure (MPa)	0.1	0.1	0.26	0.5	0.91	1.88	3.78
	0.2	0.21	0.52	1	1.81	3.78	7.53
	0.3	0.31	0.78	1.5	2.72	5.66	11.31
	0.4	0.41	1.04	2.01	3.62	7.56	15.09
	0.5	0.52	1.31	2.51	4.55	9.44	18.87
	0.6	0.63	1.57	3	5.45	11.32	22.62
	0.7	0.73	1.83	3.5	6.36	13.23	26.4
	0.8	—	2.09	4.02	7.26	15.12	30.16
	0.9	—	2.35	4.52	8.17	17.01	33.93
	1.0	—	2.61	5.03	9.08	18.9	37.7

### Allowable load

Set the load and moment to be applied to the table within the allowable values shown in the table below. (Values outside of limitations will cause excessive play, deteriorate accuracy, and shorten service life.)

Pictures	Allowable radial load (N)		Allowable thrust load (N)		Allowable moment (N.m)
	Tube I.D.		(a)	(b)	
			12	54	
16	78	74	78	2.4	
20	196	197	363	5.3	
25	314	296	451	9.7	
32	390	493	708	18	
40	543	740	1009	25	

### Rotating direction and angle

- When the port 1 is pressurized, the flange rotates in clockwise (CW) direction.
- When the port 2 is pressurized, the flange rotates in counter-clockwise (CCW) direction.

The rotating angle range can be adjust by the method shown as right figure.

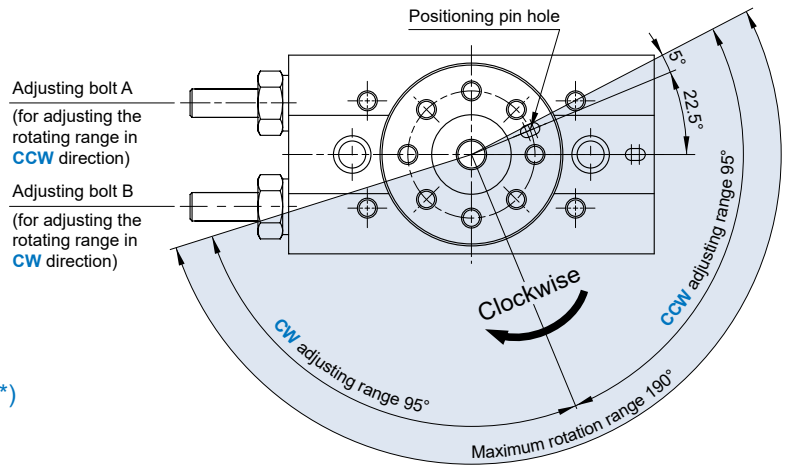
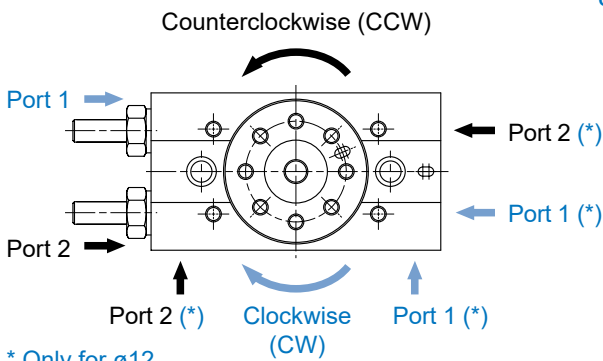

#### NOTE

- The figure shows the rotating range and use the pin hole as indicator.
- The pin hole position in the figure locates at the situation which the CCW & CW rotating range are both adjusted at 90°.

### Rotating range adjusting example

- The followed figures show the rotating range of different adjustment via bolt A and B. (The drawings also show the rotation ranges of the positioning pin hole.)

#### 190° (Max) Rotation

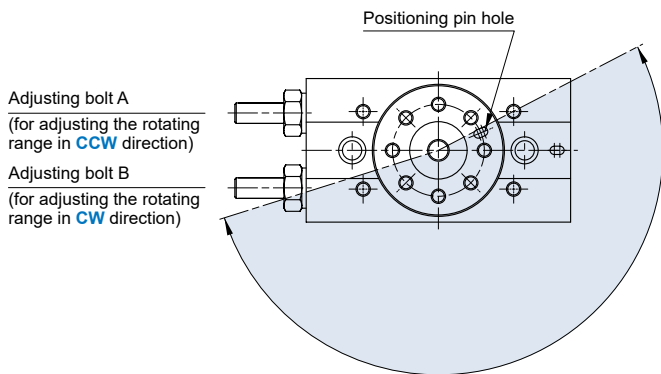

#### 180° Rotation

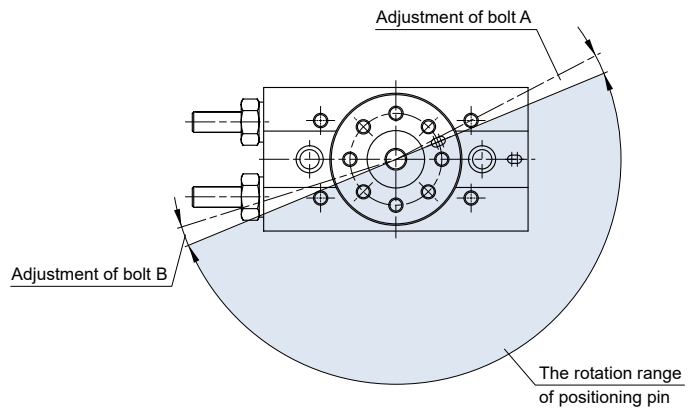

#### 90° Rotation

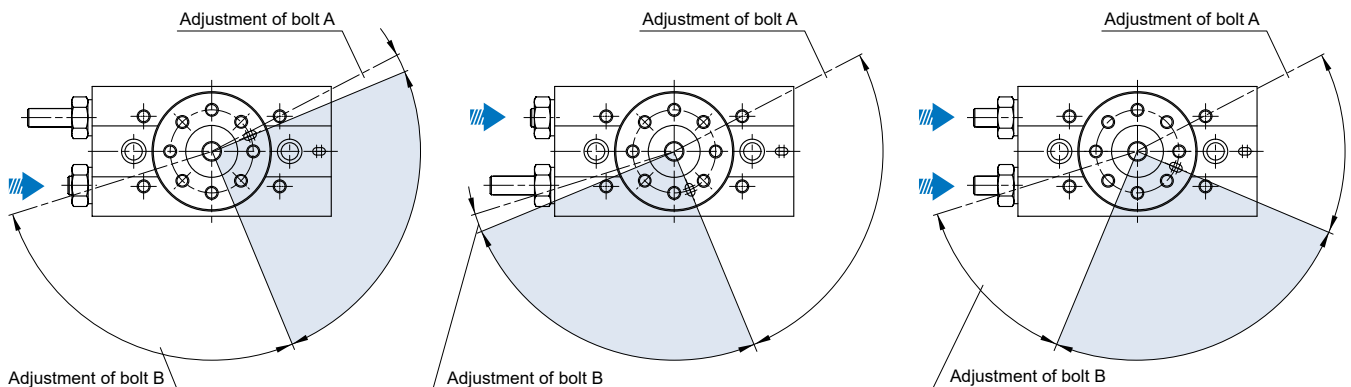

# MCRQ2 Inside structure & Parts list



## ROTARY ACTUATOR

mindman

ø16~ø32

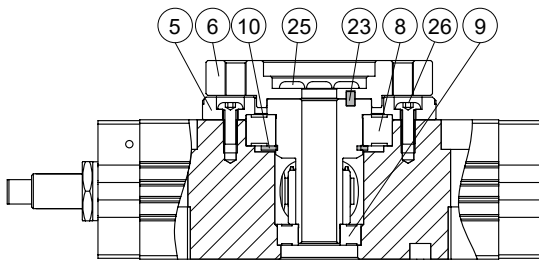
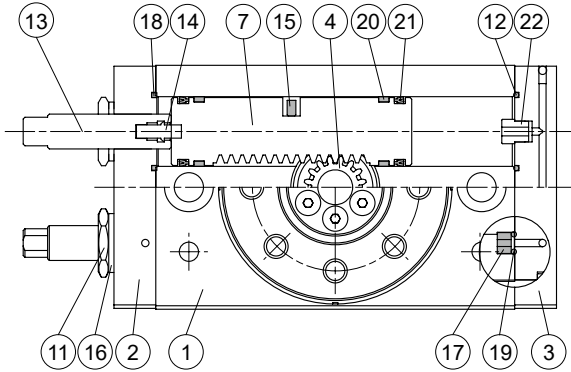

ø40

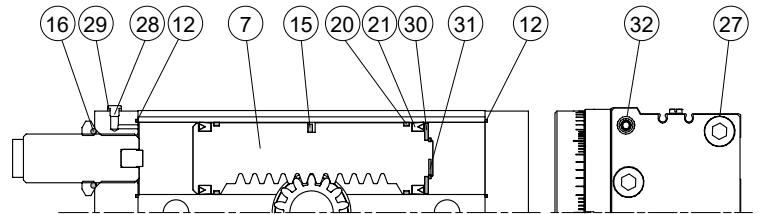

ø12

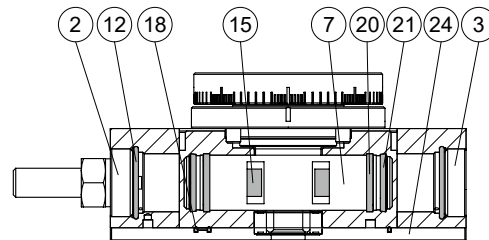

### Material

A: Repair kits (inclusion)

No.	Part name	Material	Tube I.D. & Q'y				A
			12	16	20~32	40	
1	Body	Aluminum alloy	1				
2	Cover	Aluminum alloy	2	1			
3	End cover	Aluminum alloy	2	1			
4	Pinion	SCM	1				
5	Bearing retainer	Aluminum alloy	1				
6	Table	Aluminum alloy	1				
7	Piston	Stainless steel	2				
8	Rolling bearing	Bearing steel	1				
9	Rolling bearing	Bearing steel	1				
10	Snap ring	Spring steel	-	1	-		
11	Seal nut	Carbon steel	2				
12	O-ring	NBR	4	2	4	●	
13	Adjusting bolt *1	Stainless steel *2	2				
	Shock absorber *3	-	-	2			
14	Cushion pad *1	NBR	2				●
15	Magnet	Magnet material	4	2			
16	Seal washer	*4	2				●
17	Fixed	Copper	-	4	2	-	
18	Piston packing	NBR	1	-	2	-	
19	O-ring	NBR	-	4	2	-	
20	Wear ring	Resin	4				

\*1. Only suitable for (A) with adjusting bolt. \*2. ø40: Carbon steel  
 \*3. Only suitable for (R) with shock absorber.  
 \*4. ø12~ø32: NBR+Carbon steel; ø40: NBR

A: Repair kits (inclusion)

No.	Part name	Material	Tube I.D. & Q'y						A
			12	16	20	25	32	40	
21	Piston Seal	NBR	4						●
22	Stop chunk	Aluminum alloy	-	2	-				
23	Pin *5	SCM	1						
24	Plate	Aluminum alloy	1	-					
25	Bolt	Stainless steel *6	6						
26	Bolt	Carbon steel	4	6	4	6			
27	Bolt	Stainless steel	4						
28	Plug	Copper	-	-	-	1			
29	Plug washer	PET	-	-	-	1			
30	Piston retainer	Aluminum alloy	-	-	-	2			
31	Piston snap ring	Spring steel	-	-	-	2			
32	Plug	Carbon steel	-	-	-	2			

\*5. ø20~ø40: Key  
 \*6. ø16, ø20: Carbon steel

### Order example of repair kits

Tube I.D.	Repair kits	
	Adjuster bolts (A)	Shock absorber (R)
ø12	<b>PS-MCRQ-12A</b>	-
ø16	<b>PS-MCRQ-16A</b>	<b>PS-MCRQ-16R</b>
ø20	<b>PS-MCRQ-20A</b>	<b>PS-MCRQ-20R</b>
ø25	<b>PS-MCRQ-25A</b>	<b>PS-MCRQ-25R</b>
ø32	<b>PS-MCRQ-32A</b>	<b>PS-MCRQ-32R</b>
ø40	<b>PS-MCRQ-40A</b>	<b>PS-MCRQ-40R</b>

\* Use the same repair kits with MCRQ series.

# MCRQ2 Dimensions $\phi 12$

## ROTARY ACTUATOR



Mindman

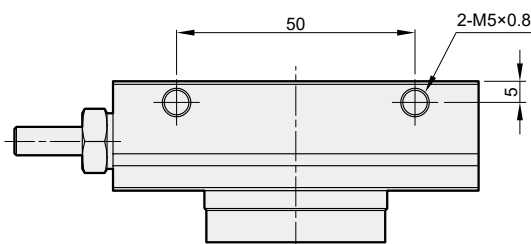
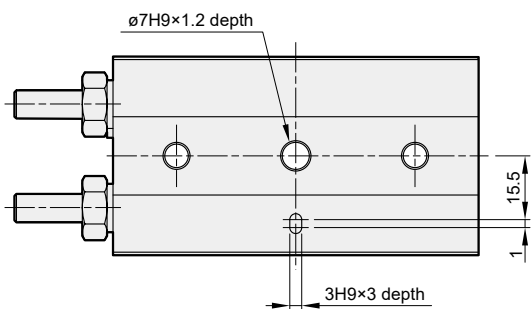
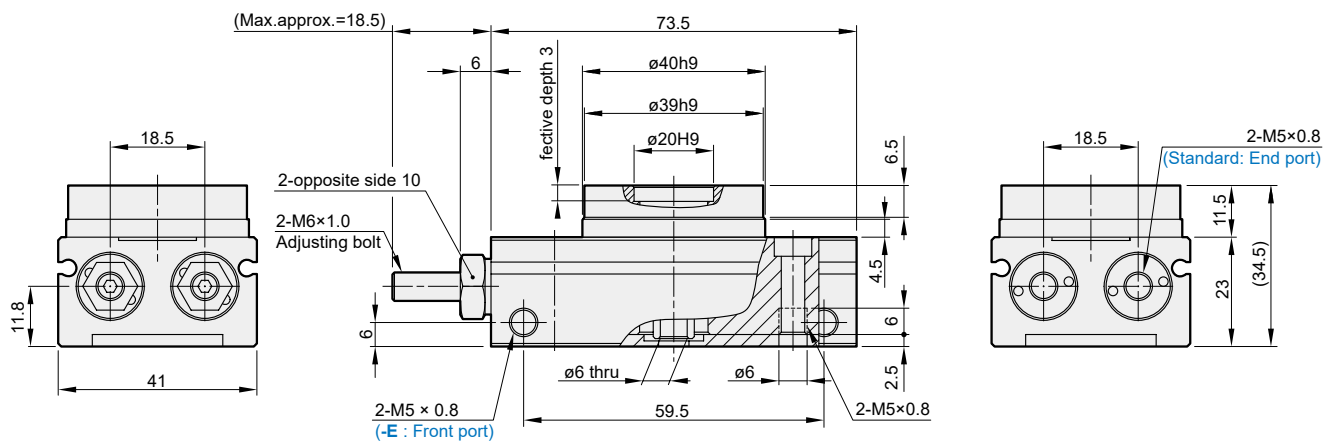
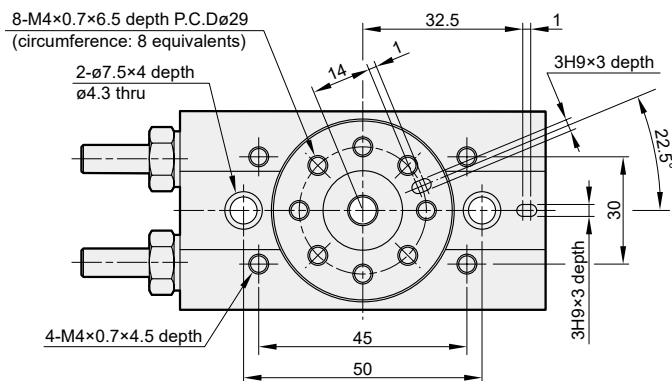

# MCRQ2 Dimensions $\varnothing 16, \varnothing 20, \varnothing 25$

## ROTARY ACTUATOR

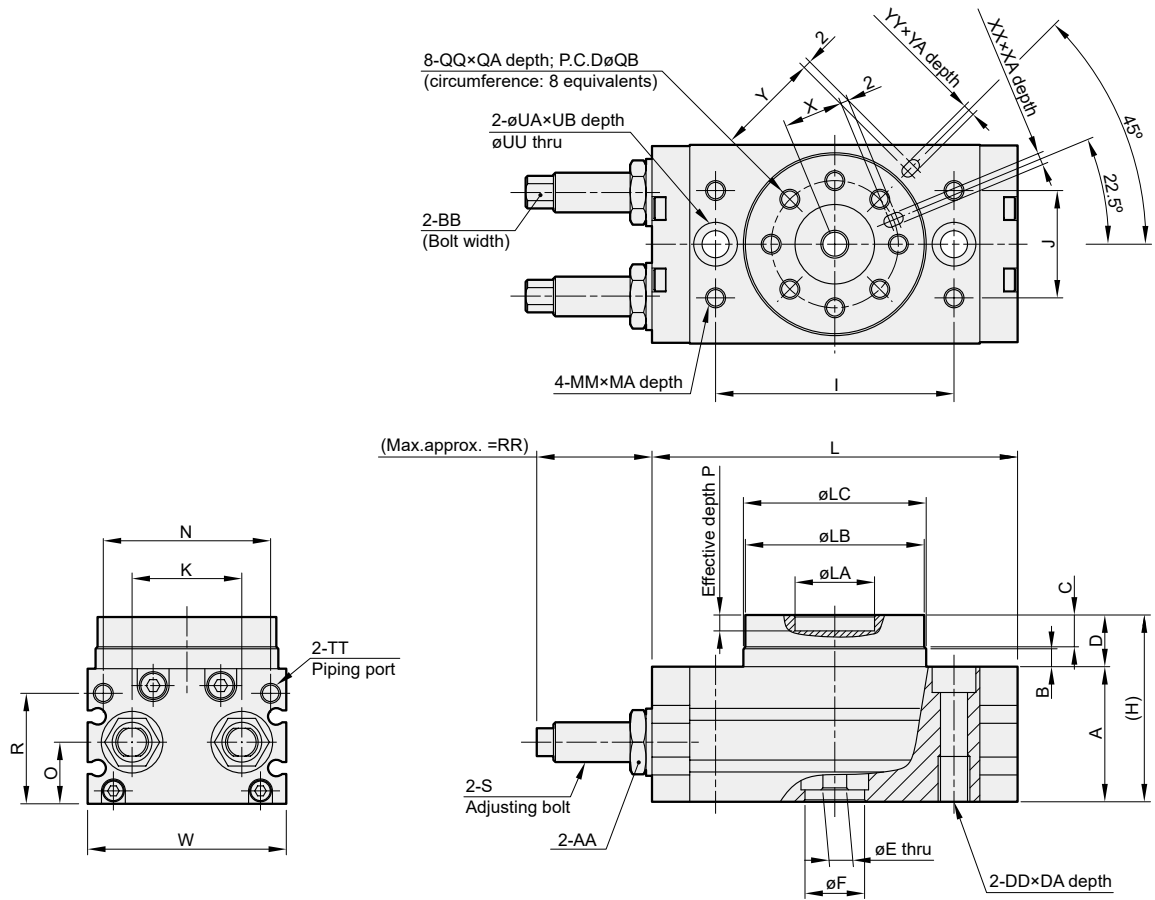

### MCRQ2-16~25R

With shock absorber

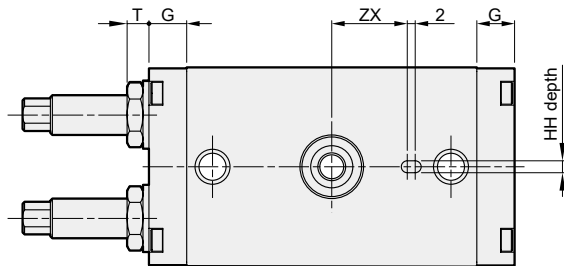
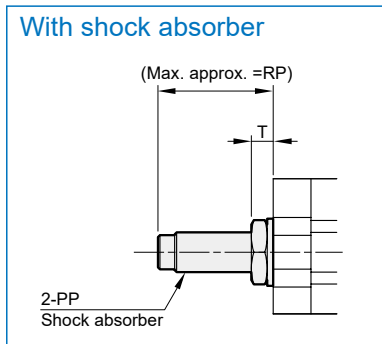

Code Tubr I.D.	A	AA	B	BB	C	D	DA	DD	E	F	G	H	HH	I	J	K	L	LA	LB	LC	MA	MM	N
16	34	14	4.5	7	8	13	12	M8×1.25	6	15H9	9.5	47	3H9×3.5	60	27	26	92	20H9	45h9	46h9	8	M5×0.8	37
20	40	17	6.5	7	10	17	15	M10×1.5	10	22H9	12	57	4H9×4.5	84	37	32	127	32H9	65h9	67h9	8	M6×1	54
25	46	22	7.5	8	12	20	18	M12×1.75	13	26H9	15.5	66	5H9×5.5	100	50	37	152	35H9	75h9	77h9	8	M8×1.25	63

Code Tubr I.D.	O	P	PP	QA	QB	QQ	R	RP	RR	S	T	TT	UA	UB	UU	W	X	XA	XX	Y	YA	YY	ZX
16	15.5	4	FK-1008L-S	8	32	M5×0.8	29	29	31	M10×1.0	5.5	M5×0.8	11	6.5	6.8	50	15	3.5	3H9	27	3.5	3H9	19
20	19.5	4.5	FK-1008L-S	10	48	M6×1.0	33	23.5	26	M10×1.0	4.5	Rc1/8	14	8.5	8.6	70	23	4.5	4H9	39	4.5	4H9	28
25	22	5	FK-1412L-S	12	55	M8×1.25	37.5	33	31.2	M14×1.5	7.5	Rc1/8	18	10.5	10.5	80	26.5	5.5	5H9	45	5.5	5H9	33

### MCRQ2-32R, 40R

With shock absorber

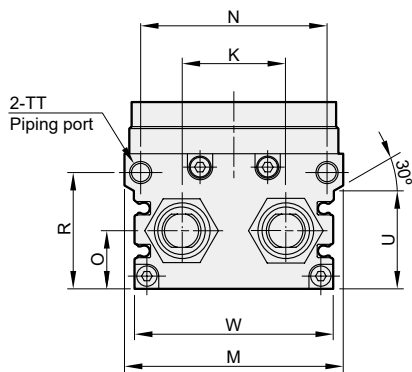
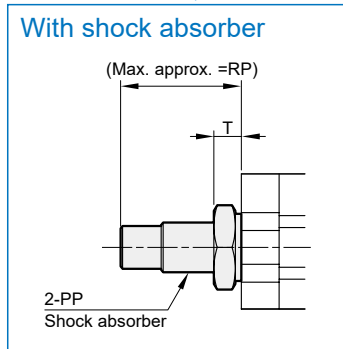

### MCRQ2-40

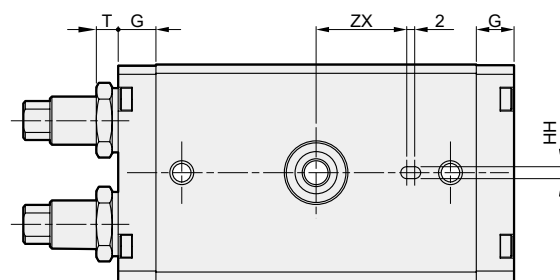
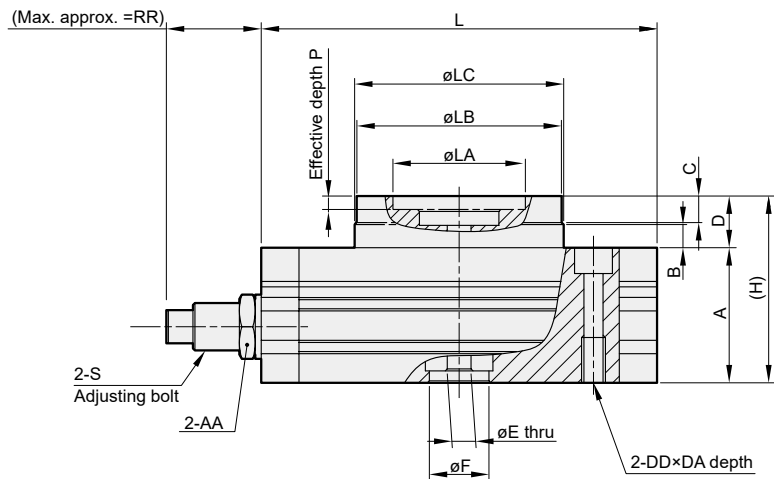
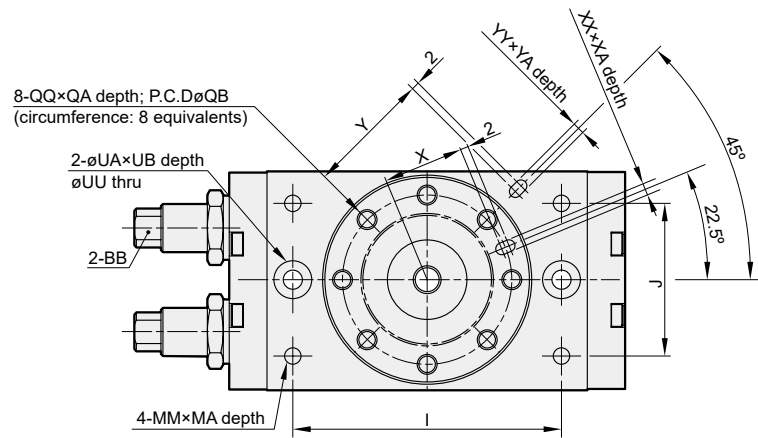
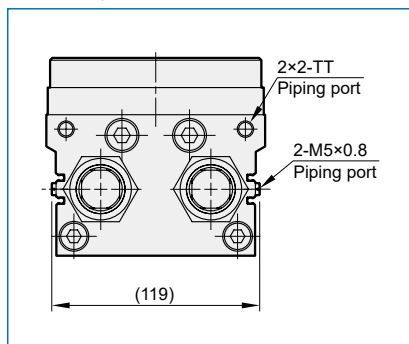

Code Tubr I.D.	A	AA	B	BB	C	D	DA	DD	E	F	G	H	HH	I	J	K	L	LA	LB	LC	M	MA
32	59	30	12	Bolt width 12	14.5	27	18	M12x1.75	13	24H9	17	86	6H9x4.5 dp	130	66	47	189	56H9	98h9	100h9	102	10
40	74	36	15	Bolt width 21	16.5	32	25	M16x2.0	24	32H9	24	106	8H9x6.5 dp	150	80	60	240	64H9	116h9	118h9	120	13

Code Tubr I.D.	MM	N	O	P	PP	QA	QB	QQ	R	RP	RR	S	T	TT	U	UA	UB	UU	W	X	XA
32	M8x1.25	85	27.5	6	FK-2016L-S	14.5	77	M10x1.5	50.5	46	38.1	M20x1.5	10.5	Rc1/8	42	18	10.5	10.5	95	37.5	6.5
40	M12x1.75	100	37	9	FK-2725L-S	16.5	90	M12x1.75	65.5	68	45	M27x1.5	7	Rc1/8	57	20	12.5	14.2	113	44	8.5

Code Tubr I.D.	XX	Y	YA	YY	ZX
32	6H9	59	4.5	6H9	49
40	8H9	69	4.5	8H9	54