

ELECTRIC
GRIPPER



MEHC3 series

User Manual

Easy-Control Electric Gripper



Contents

1. Safety Precautions	1
2. Product Description	3
2.1 System Structure	3
2.2 Specification	4
2.3 Possible Applications.....	4
3. I/O Function and Pin Assignment	5
3.1 I/O Functions	5
3.2 I/O Pin Assignment.....	5
3.3 I/O Circuit Specification	6
3.3.1 Input Circuit – Size 16	6
3.3.2 Input Circuit – Size 25	6
3.3.3 Output Circuit	7
4. Operation.....	8
4.1 Operation Process and Motion Mechanism	8
4.2 Control and Signal Timing	9
4.2.1 Gripper Closing and Opening.....	9
4.2.2 Gripping Force Setting	9
5. Status and LED	10

1. Safety Precautions

Before installing, operating, or maintaining this product, carefully read this manual and all related documentation to fully understand the product characteristics, safety information, and precautions to ensure correct usage.

Safety notices are classified as:

 Warning	Improper operation may result in death or serious injury.
 Caution	Improper operation may result in personal injury or property damage.
 Important	Although there is no possibility of injury, these are the contents that should be observed in order to use this product appropriately.

- ◆ Even items classified as “Caution” or “Important” may result in serious consequences depending on the circumstances.

 Warning	<p>General</p> <ul style="list-style-type: none"> ● This product is not explosion-proof. Do not use it in environments with explosive gas, flammable gas, corrosive gas, or areas prone to oil, water, chemicals, or near flammable materials, as this could cause fires or injuries. ● Do not use this product in environments with direct sunlight (UV rays), near magnetic or radioactive materials, in dusty areas, with salts, iron powder, high humidity, or with organic solvents, phosphate ester oils, etc., as this could cause fires or injuries. ● Do not use this product for medical devices related to life support, health management, or key components for transporting people. ● Installation, wiring, operation, and troubleshooting should be performed by qualified professionals to avoid fire, injury, or device damage. ● Ensure the product is completely powered off and all LED indicators are off before performing installation, wiring, operation, or troubleshooting to avoid electric shock. ● After power is turned off, the internal motor loses holding force. Although it has a self-locking mechanism, loosening may still occur. Take appropriate measures to prevent injury or device damage. ● Depending on the type of alarm, the motor may stop and lose holding force. Design appropriate safety circuits, devices, or measures to prevent injury or device damage due to emergency stops, power outages, or system malfunctions. ● When an alarm occurs, always eliminate the cause before resetting the alarm. Continuing to operate without addressing the cause may result in abnormal motor or controller operation, leading to injury or device damage. <p>Wiring</p> <ul style="list-style-type: none"> ● The product should be properly grounded to prevent electric shock, static electricity, improve interference resistance, and avoid abnormal operation of the motor and controller. ● Before powering the product or starting it, ensure that it operates within the rated working range. Improper power supply may cause injury or device damage. ● Wiring should follow the instructions in the user manual to avoid incorrect connections. Ensure that cables and connectors are secure to prevent abnormal operation or fire. ● Do not excessively bend, pull, clamp, or place heavy objects on the cables. This could cause cable damage, leakage, or poor conductivity, leading to fire, electric shock, or abnormal operation of the motor and controller. ● If there are wires or cables not specified in the manual, do not use them without consulting the sales or dealer from whom you purchased the product.
-------------------------------------------------------------------------------------------------------	-------------------------------------------------------------------------------------------------------------------------------------------------------------------------------------------------------------------------------------------------------------------------------------------------------------------------------------------------------------------------------------------------------------------------------------------------------------------------------------------------------------------------------------------------------------------------------------------------------------------------------------------------------------------------------------------------------------------------------------------------------------------------------------------------------------------------------------------------------------------------------------------------------------------------------------------------------------------------------------------------------------------------------------------------------------------------------------------------------------------------------------------------------------------------------------------------------------------------------------------------------------------------------------------------------------------------------------------------------------------------------------------------------------------------------------------------------------------------------------------------------------------------------------------------------------------------------------------------------------------------------------------------------------------------------------------------------------------------------------------------------------------------------------------------------------------------------------------------------------------------------------------------------------------------------------------------------------------------------------------------------------------------------------------------------------------------------------------------------------------------------------------------------------------------------------------------------------------------------------------------------------------------------------------------------------------------------------------------------------------------------------------------------------------------------------------------------------------------------------------------------------------------------------------------------------------------------------------------------------------------------------------------------------------------------------------------------------------------------------------------------------------------------------------------------------------------------------



Warning

Operation

- In the event of a power outage, make sure to disconnect the product's power supply. Sudden startup after power restoration may cause injury or device damage.
- Do not interrupt the power supply during operation, as the motor will stop and lose holding force, which may result in injury or device damage.
- Use the product within the load range specified in the catalog. Exceeding this range may cause excessive off-center load on the gripper's sliding parts, severely affecting the product's lifespan.
- Design the gripper's soft jaws to be short and light. Long and heavy soft jaws create excessive inertia during opening and closing, which can cause the gripper to loosen. Even within the grip point's limit range, keep soft jaws as short and light as possible. For long or large workpieces, consider using larger specifications or multiple grippers simultaneously.

Repair, Disassembly, and Modification

- Do not disassemble or modify the product, as this may cause injury or damage. If internal inspection or repair is necessary, please contact our company's service center.



Caution

General

- Do not exceed the specified limits of the product, as this may cause malfunctions, ineffective operations, or breakage, significantly reducing the product's lifespan and potentially causing injury or device damage.
- Do not insert fingers or objects into the openings or moving parts of the product, as this may result in injury or damage to the device.
- Do not install the product in locations prone to significant vibration or impact, as this may cause abnormal operation.
- Ensure an emergency stop device is installed in an appropriate location to allow immediate halting of operations in the event of danger, preventing potential injuries.

Installation and Setup

- Ensure sufficient space for maintenance operations during installation. Inadequate space can hinder routine checks and maintenance, potentially leading to equipment shutdowns or damage.
- When installing multiple units, maintain adequate spacing and use cooling devices to keep the product environment at 50°C or below. Avoid placing items that obstruct ventilation nearby.

Operation

- Do not touch terminals and switches when the power is on. Doing so may result in electric shock or abnormal operation.
- If the product exhibits abnormal heat, smoke, or odor, immediately disconnect the power supply.

Maintenance

- Before inspection, maintenance, or replacements on the product, make sure to completely disconnect the power supply and input/output signals.

2. Product Description

The MEHC3 Easy-Control Electric Gripper is developed based on the MEHC2 Electric Gripper and the MCHC Pneumatic Gripper. The jaws provide up to seven types for users to choose from.

The motor and controller are integrated within the gripper, eliminating the need for additional installation and configuration. Using I/O signal settings, users can easily grip and release the workpiece and adjust the gripping force. Additionally, the MEHC3 features multiple mounting surfaces, offering up to five installation methods.

2.1 System Structure

- I/O control via upper controller

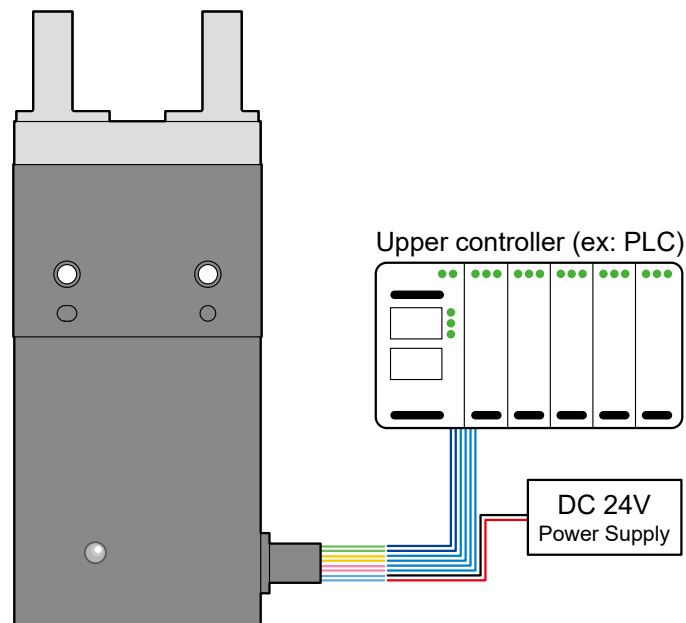

- Push or knob button control

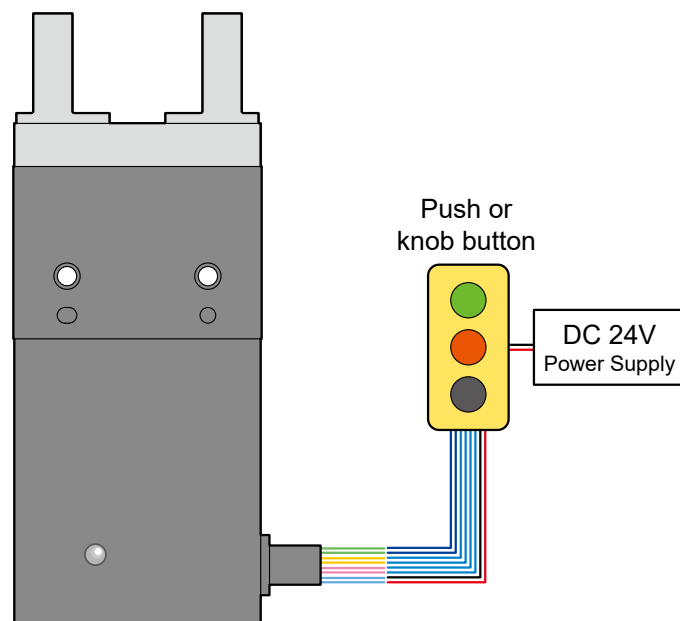

2.2 Specification

Model		MEHC3		
Size		16	25	
Total stroke	mm	6	14	
Gripping force (*1)	Level 1	N	12	25
	Level 2	N	17	33
	Level 3	N	22	41
Opening / Closing time	Sec	0.5		
Transmission		Lead screw		
Guide type		Non-recirculating linear bearings		
Repeatability	mm	±0.02		
Operating temperature	°C	5 ~ 40		
Operating humidity	%RH	Less than 85 (Non-condensing, no dew formation)		
Control method		I/O · Built-in controller		
I/O interface		Input 3 points (PNP) Output 1 points (NPN)	Input 3 points (NPN) Output 1 points (NPN)	
Rated voltage	V	DC 24 ± 10%		
Power consumption (*2)	Standby	W	1	1
	Level 1	W	3	3
	Level 2	W	6	5
	Level 3	W	9	7
Weight	kg	0.3	0.8	

*1. Gripping force tolerance ±20% F.S.

*2. Power consumption at each force level indicates the peak instantaneous power usage.

2.3 Possible Applications

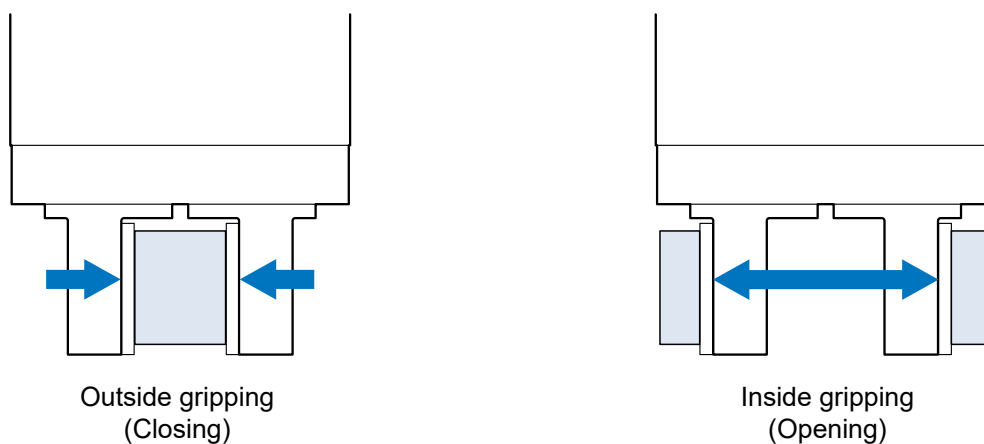

3. I/O Function and Pin Assignment

3.1 I/O Functions

Input 3	Input 2	Input 1	Function
Off	Off	On	Outside gripping
Off	On	Off	Inside gripping
On	Off	Off	Alarm reset
On	Off	On	Set gripping force level 1
On	On	Off	Set gripping force level 2
On	On	On	Set gripping force level 3

Output 1	Gripping force has reached the set value
----------	------------------------------------------



Caution

- If the gripper reaches its mechanical limit or becomes jammed for any reason, it may trigger the Output 1 signal.

3.2 I/O Pin Assignment

Size 16

Pin No.	Function	Color
1	VCC (24VDC)	■ ■ ■ ■ ■ ■ ■ ■
2	GND	■ ■ ■ ■ ■ ■ ■ ■
3	Input 1	■ ■ ■ ■ ■ ■ ■ ■
4	Input 2	■ ■ ■ ■ ■ ■ ■ ■
5	Input 3	■ ■ ■ ■ ■ ■ ■ ■
6	Input Com-	■ ■ ■ ■ ■ ■ ■ ■
7	Output 1	■ ■ ■ ■ ■ ■ ■ ■
8	Output 1 Com-	■ ■ ■ ■ ■ ■ ■ ■

Size 25

Pin No.	Function	Color
1	VCC (24VDC)	■ ■ ■ ■ ■ ■ ■ ■
2	GND	■ ■ ■ ■ ■ ■ ■ ■
3	Input Com	■ ■ ■ ■ ■ ■ ■ ■
4	Input 1	■ ■ ■ ■ ■ ■ ■ ■
5	Input 2	■ ■ ■ ■ ■ ■ ■ ■
6	Input 3	■ ■ ■ ■ ■ ■ ■ ■
7	Output 1	■ ■ ■ ■ ■ ■ ■ ■
8	Output 1 Com-	■ ■ ■ ■ ■ ■ ■ ■



Caution

- The wire colors shown are for reference purposes only. Actual colors may vary due to differences in printing or screen display settings. Please refer to the actual product for accurate information and use with caution.

3.3 I/O Circuit Specification

3.3.1 Input Circuit – Size 16

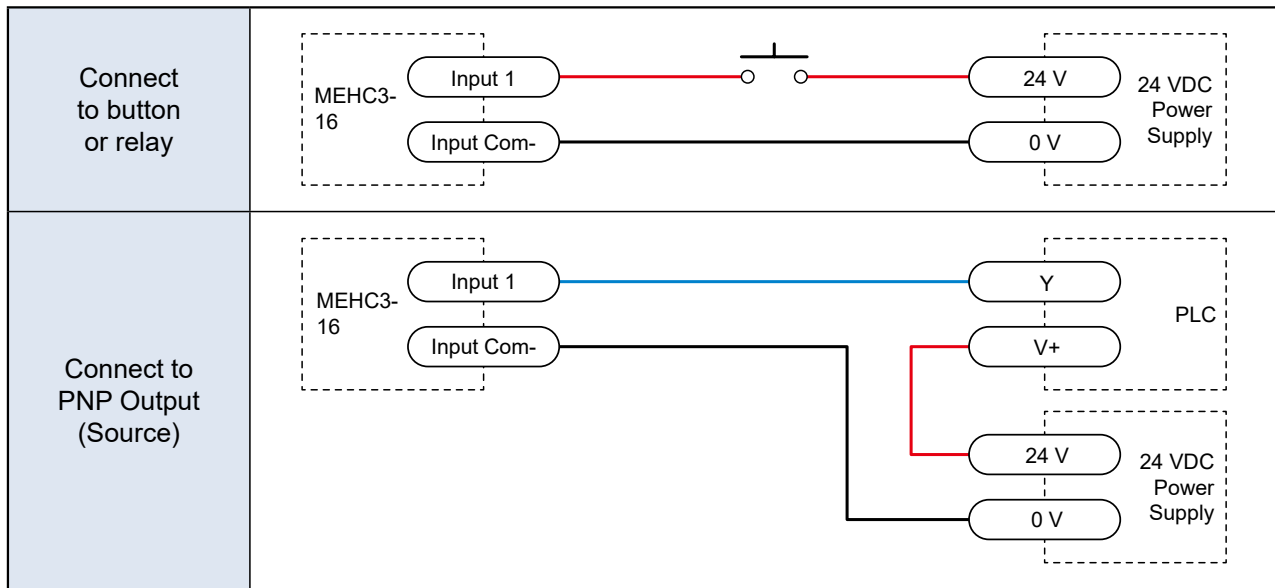

Caution

- The 「Input」 terminal is compatible with 5 ~ 24 VDC.

3.3.2 Input Circuit – Size 25

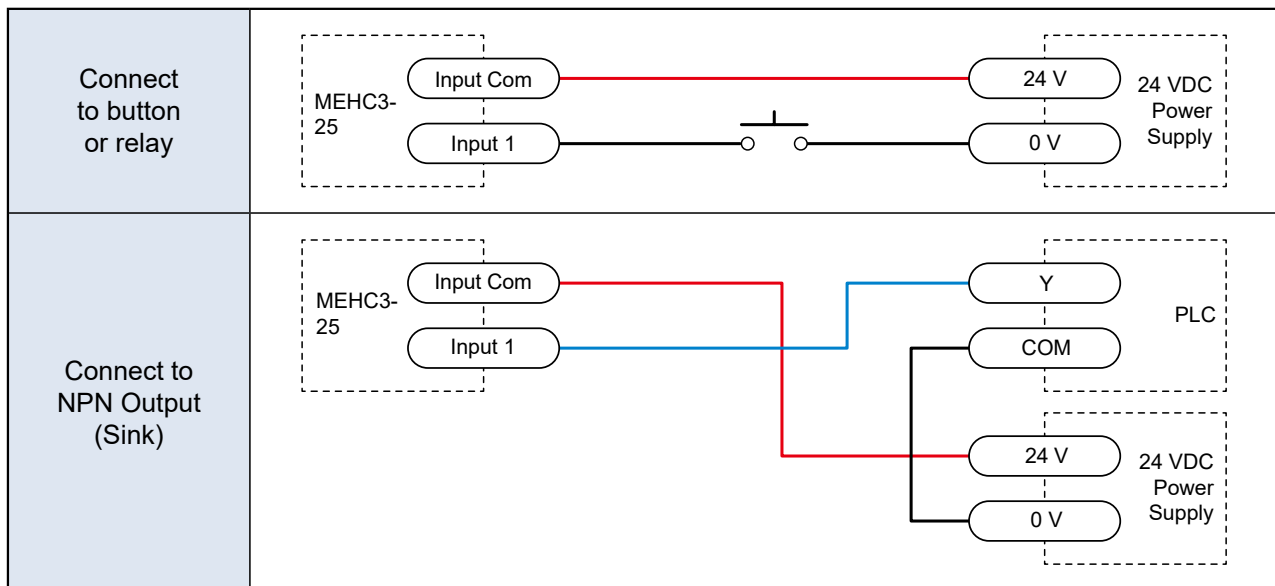

Caution

- The 「Input Com」 terminal is compatible with 5 ~ 24 VDC.

3.3.3 Output Circuit

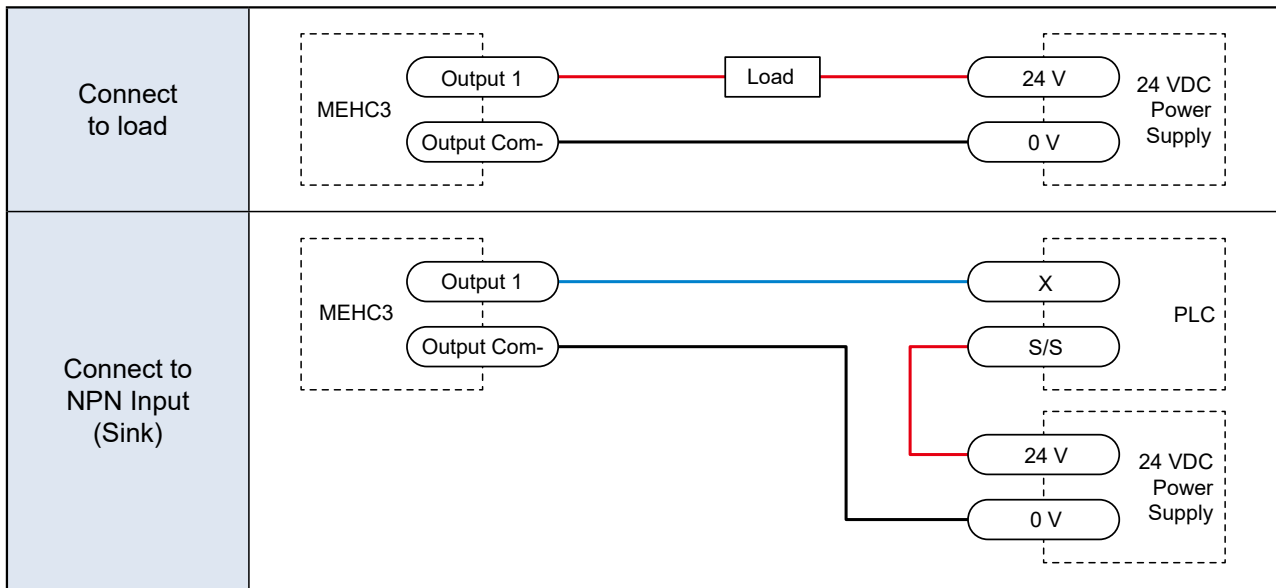

Caution

- Do not connect the output terminal to a DC voltage higher than 26.5 V.
- The current through the output terminal should not exceed 50 mA.

4. Operation

4.1 Operation Process and Motion Mechanism

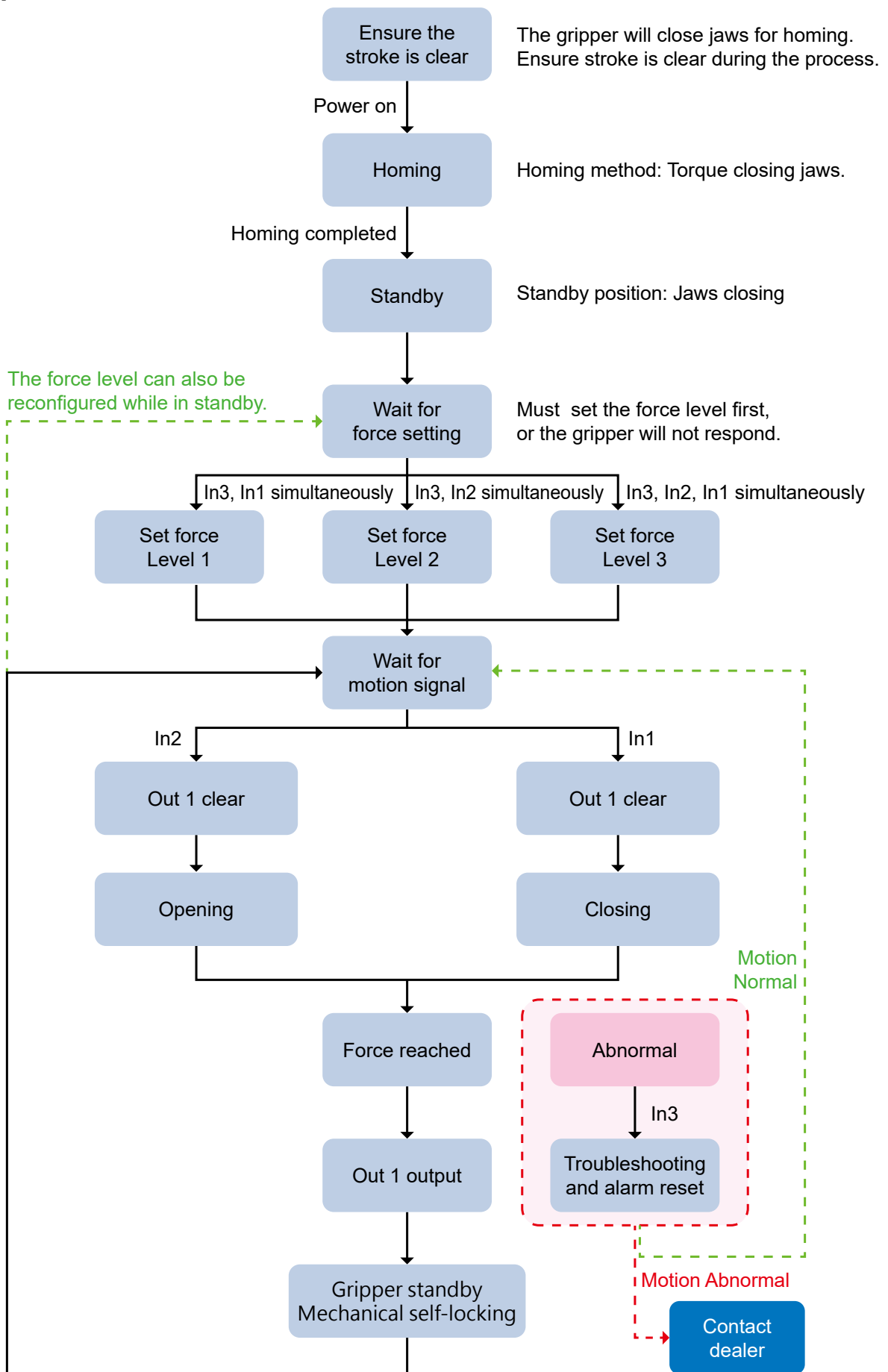

4.2 Control and Signal Timing

4.2.1 Gripper Closing and Opening

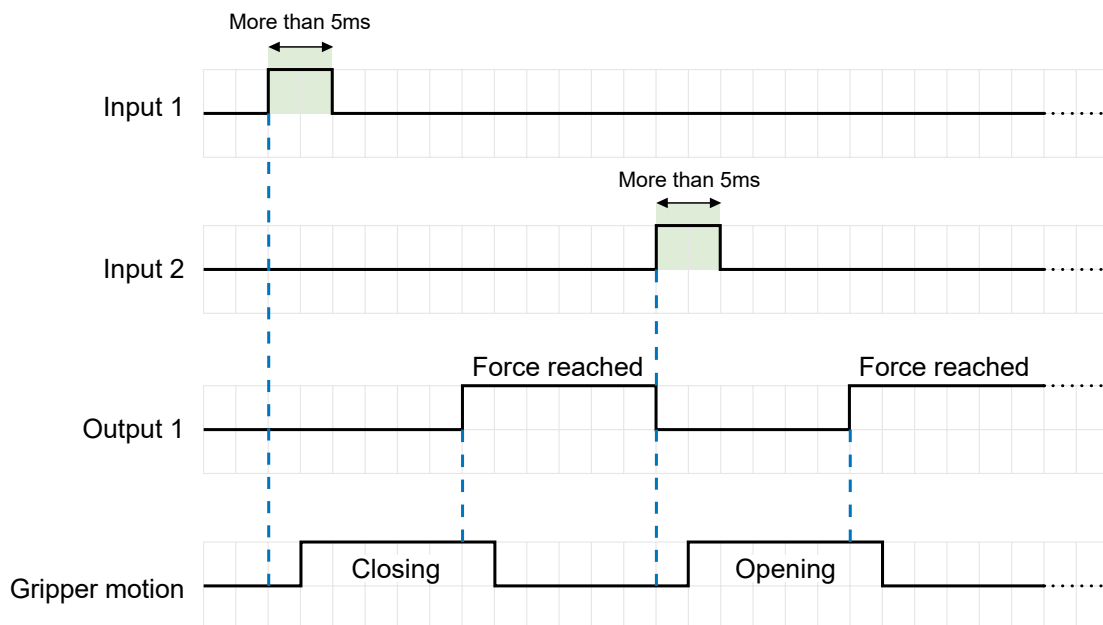

4.2.2 Gripping Force Setting

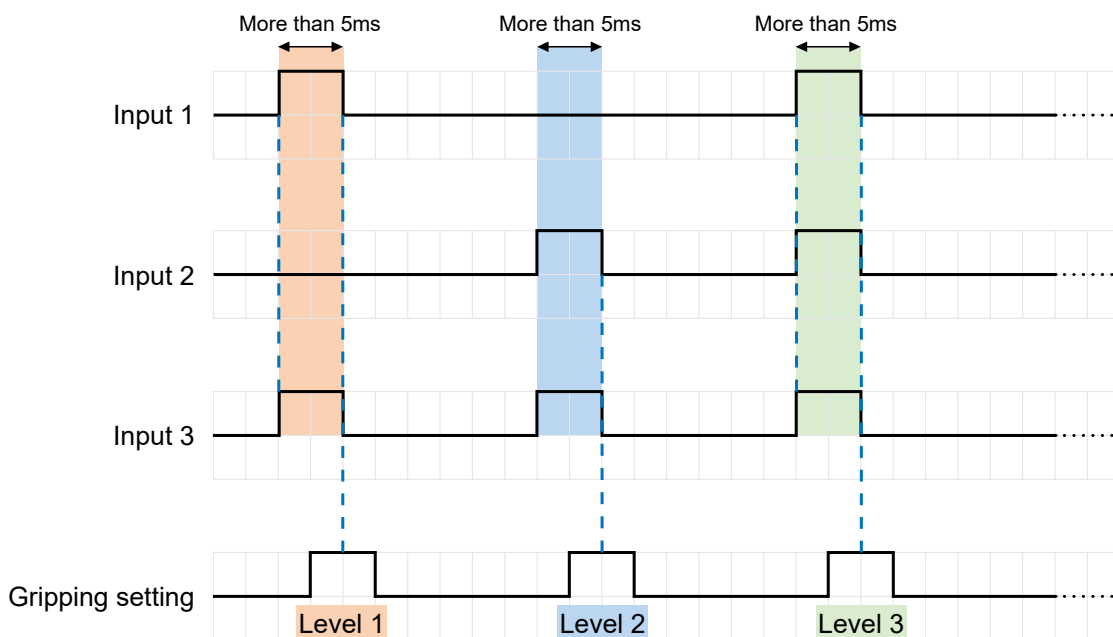

Important

- When setting the gripping force, please sequentially decrease or increase the force level.

5. Status and LED

When the gripper is in operation, the status LED will display the current operating status using green/red signals.

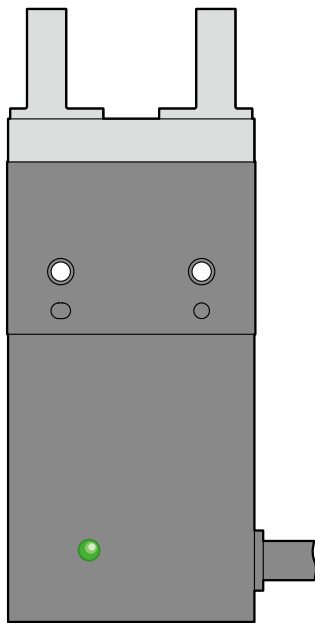

Green Light

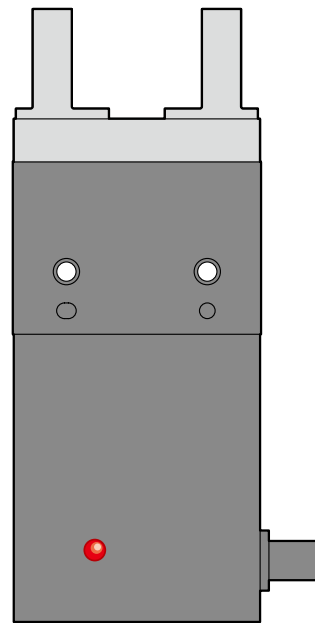

Red Light

LED display		Status
●	Green LED lights up continuously	Running
● ●	Green LED flashing	Standby
● ... ● ●	Others	Internal error
	No LED lights up	



Caution

- When an "internal error" occurs and cannot be resolved by "Alarm Reset", please contact your local dealer.