

MESF-20 series

MINIATURE ELECTRIC CYLINDER (WITH MOTOR)

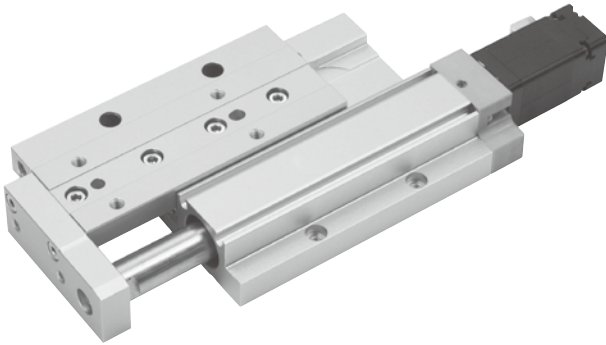

Specification

Model	MESF-20	
Repeatability (mm)	±0.02	
Ball screw lead (mm)	1	6
Maximum speed (mm/s)*	50	250
Maximum payload	Horizontal (kg)	6
	Vertical (kg)	2
Rated thrust (N)	466	75
Stroke (mm)	30 / 50	
Motor dimension (mm)	□25	
Ball screw spec (mm)	C10ø6	

* The maximum speed shown here is when software speed setting is 100%.

Order example of cylinder

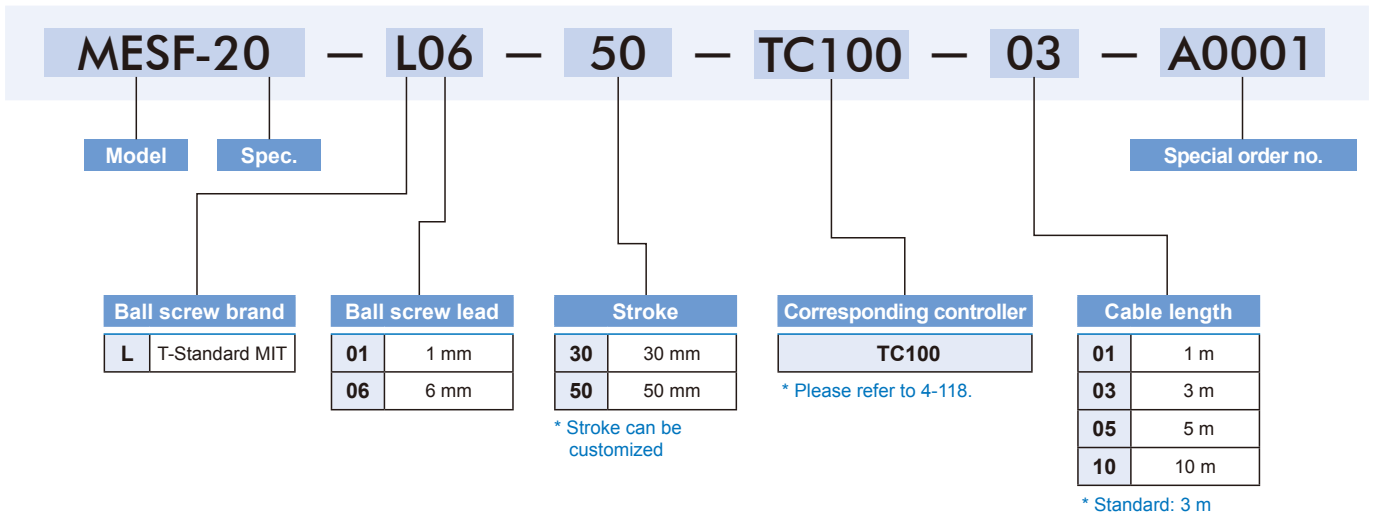

Order example of controller

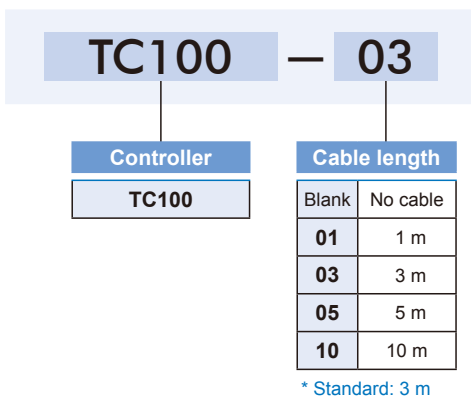

Speed-payload curve diagram

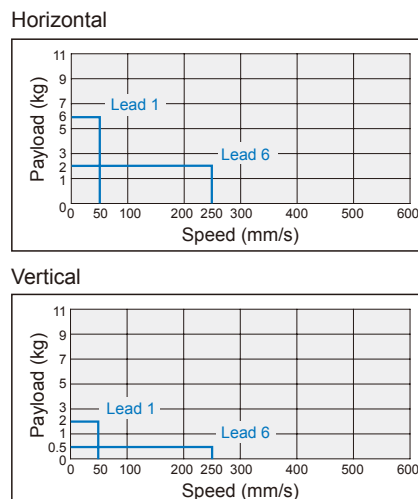

MESF-20 Dimensions

MINIATURE ELECTRIC CYLINDER (WITH MOTOR)

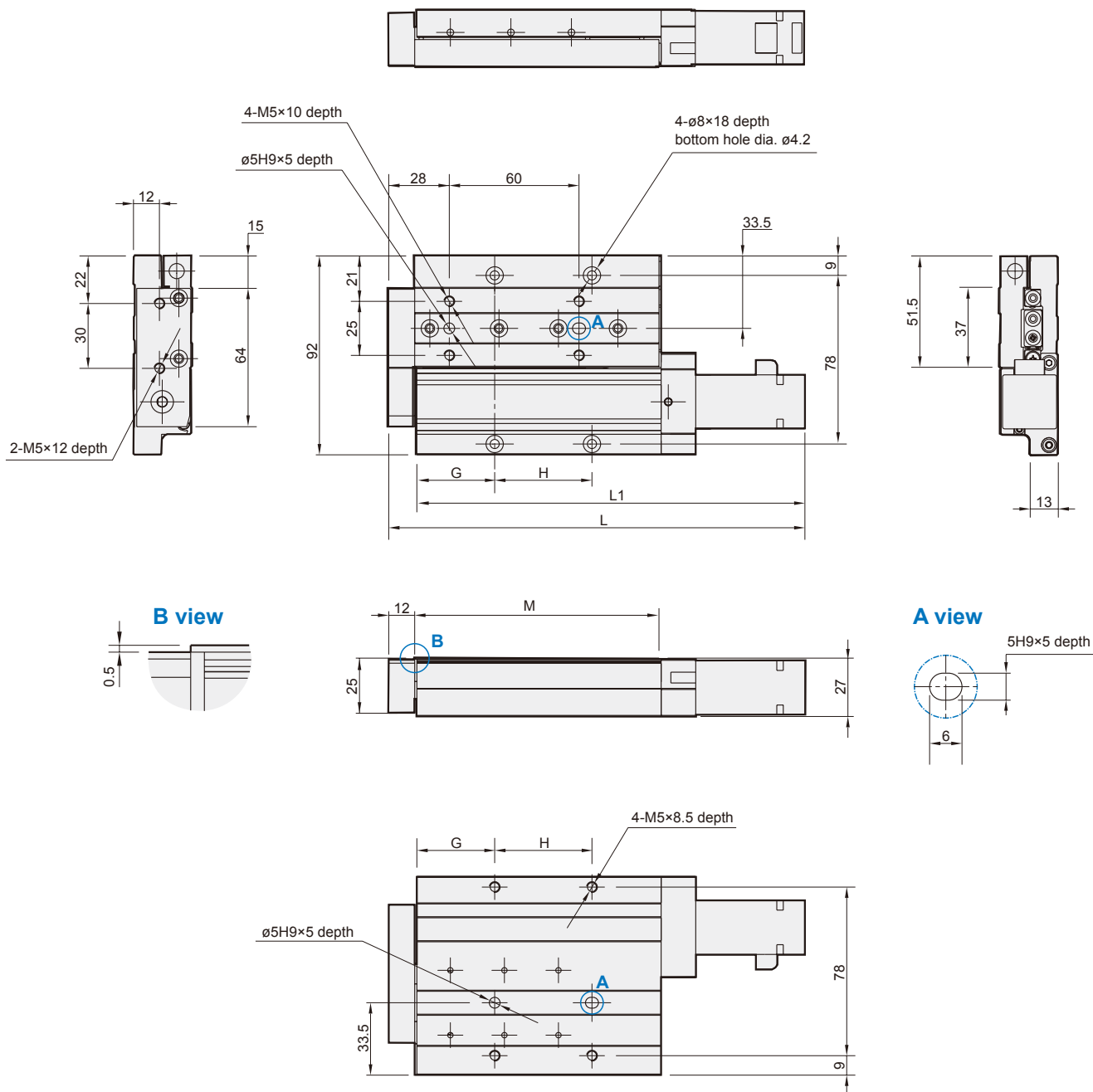

Unit: mm

Stroke	L	L1	G	H	M	Weight (g)
30	170.5	157.5	29	30	91	742
50	192.5	179.5	36	45	113	1058