

### Point 1 Customized sliders upon request

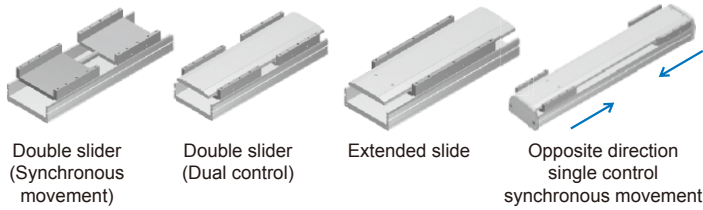

### Point 2 Patent grease nipple design (Option)

The industry only patented grease nipple design allow the customer to lubricate from outside of the slider. The ball nuts and linear guide can be lubricated and the maintenance become more convenient and faster. The assembly direction of grease nipple can be selected upon your request.

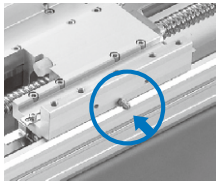

Note. This option is only for METSC-10 / METSC-12 / METSC-13

Patented grease fitting design (Copyright)®

### Point 3 Motor assemble location

The motor mounted position can be chosen upon your request and this make it more flexible for customers to design their machines.

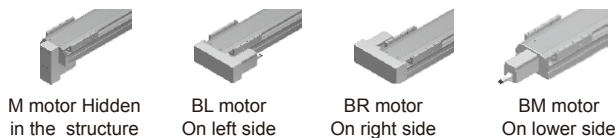

### Point 4 Servo stepping motor

High performance closed circuit stepping motor with encoder will not be out of steps even with high speed movement. Smoother movement and more accurate positioning.

### Point 5 Motor cable and encoder cable are integrated to one connector.

#### Advantage

1. No extra cables and space saving.
2. Integrated compact design and better outlooking.

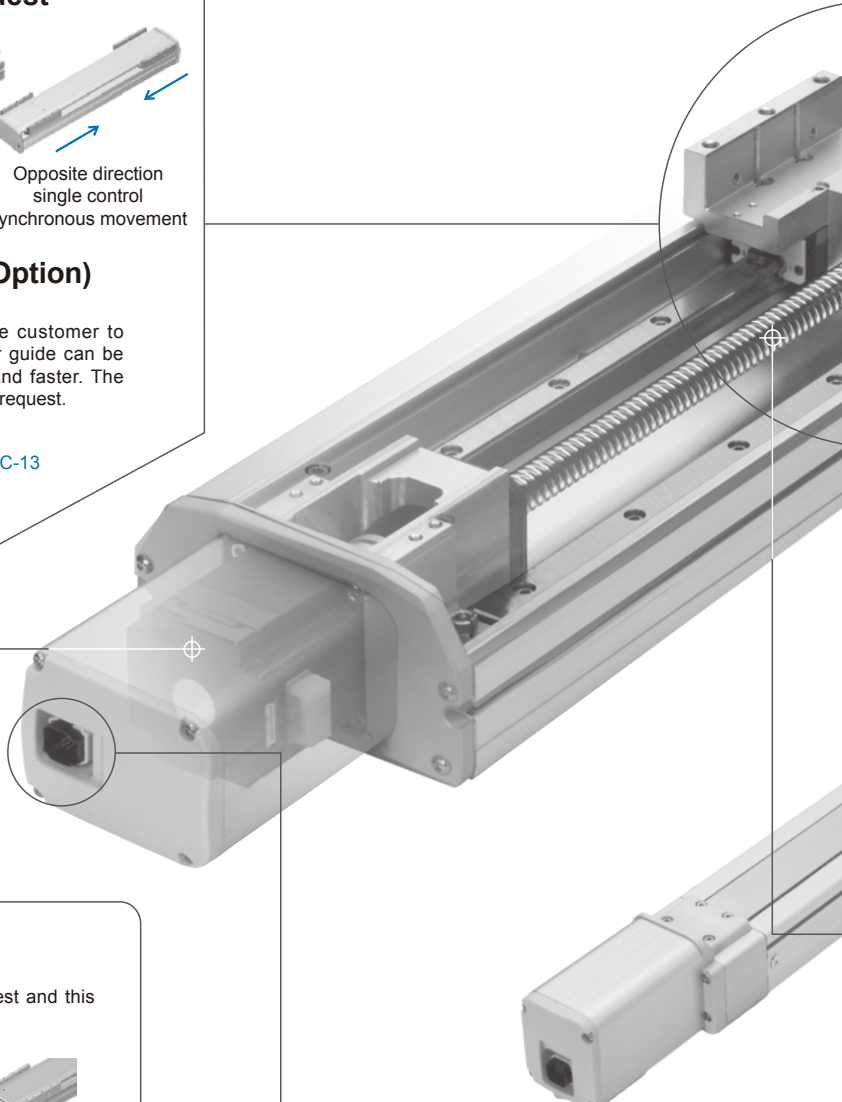

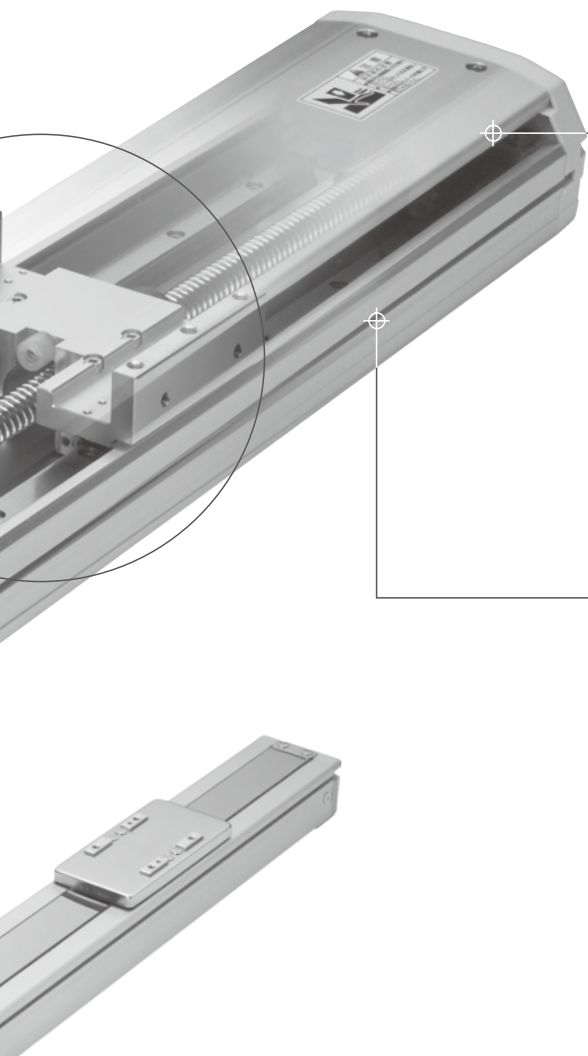

### Point 6 High rigidity profile and cover

#### High rigidity profile and cover

One piece extruded aluminum structure. By elemental analysis, the structure design is the best in stiffness and weight ratio.

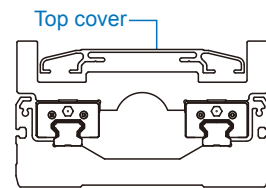

#### Torsion resistance top cover

Special torsion-resistant top cover design to prevent deformation during long stroke.

### Point 7 Sensor position (Option)

Optional external SENSOR locations.

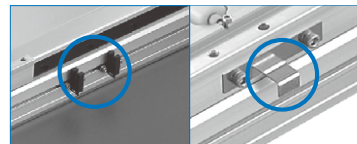

External SENSOR      External SENSOR trigger device

### Point 8 Ball screw lead

The ball screw spec and lead can be customized depending on your request of accuracy and speed.

Screw lead	
05	5 mm
10	10 mm
20	20 mm