

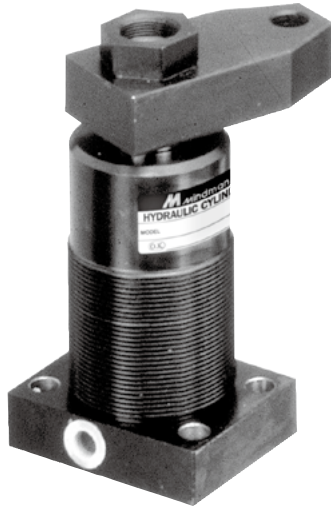

Caution for safety  
(Read before installing)



### Features

- Double clamp retracting, the piston rod rotates, causing the clamping arm to swing in either a clockwise or counterclockwise direction. Clamping then takes place as the rod continues to retract in a straight line, pulling the arm against the workpieces.
- Pull cylinder type, Available models offer angles of rotation of 0°, 45°, 60° or 90°.
- The cylinder body is made of carbon steel and the surface is hard membrane treated.

### Note

- When it is necessary to change the length of the clamping arm, it should be noted that do not exceed 1.2 times of the original G value in order to avoid the serious slanting of the piston rod.
- Suggested to add a flow control valve to the hydraulic inlet to control the motion of the swing angle in order to prevent the inertial impaction.
- A workpiece should not be clamped within a swing stroke, and it should be calmped within the vertical downward clamping stroke.
- Whenever placing and taking off a workpiece, it is necessary to use an air gun to clean the piston and the seal for removing the iron slag or foreigner objects attached thereon in order to prevent the foreigner objects form entering the seal to cause oil leakage.

### Order example

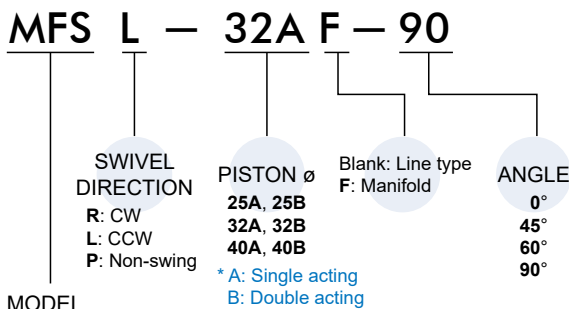

MODEL

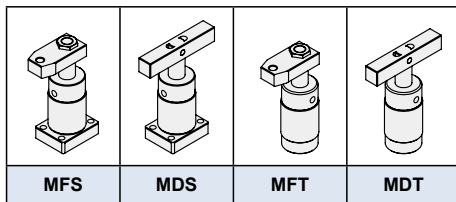

### Swivel dir. definition

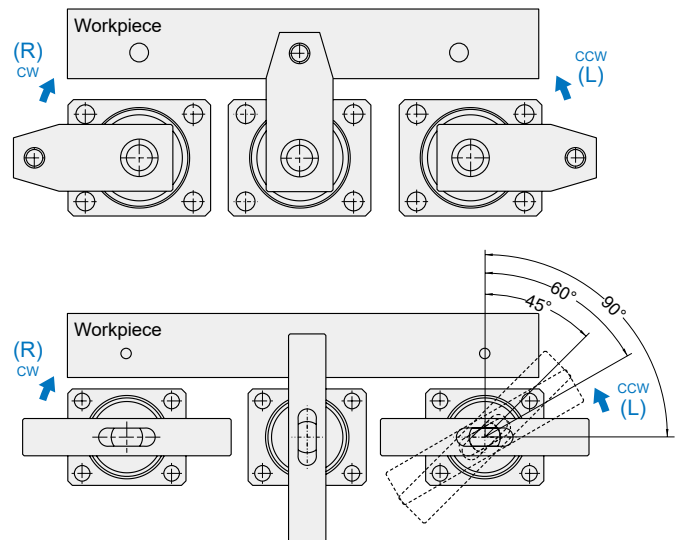

Schematic view showing a theoretical clamping force under different hydraulic pressure.

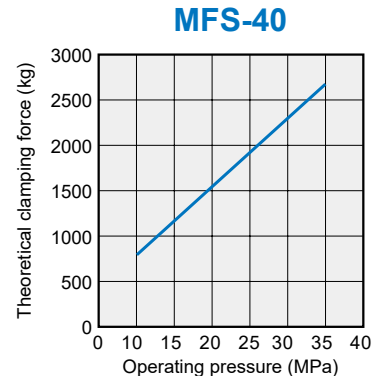
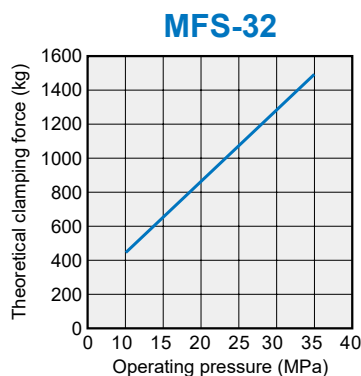
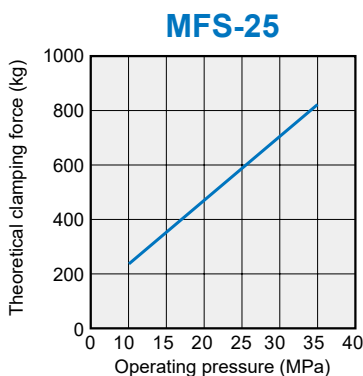

# MF\* / MD\* Dimensions $\phi 25\sim\phi 40$



## HIGH OIL PRESSURE SWING CLAMP CYLINDER

mindman

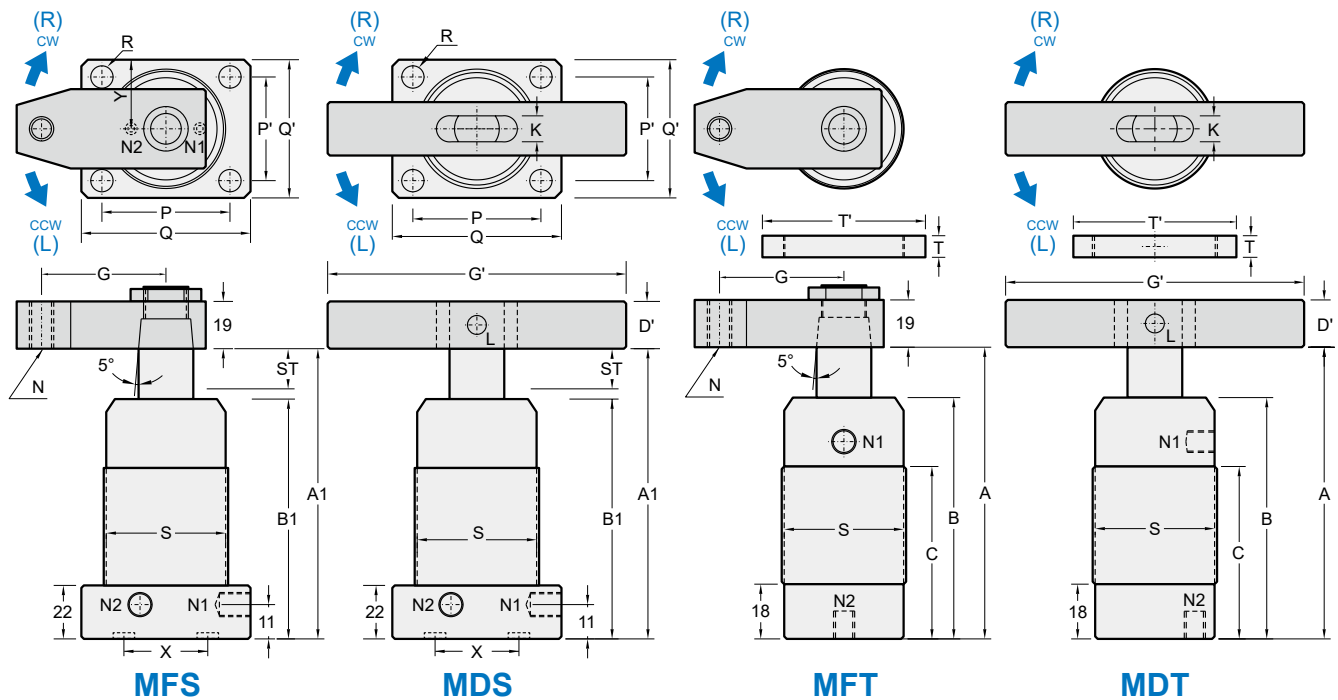

MFS / MDS (Flange type)	25A	32A	40A	25B	32B	40B
MFT / MDT (Threaded type)						
Operating pressure range	5~21 MPa					
Proof pressure	35 MPa					
Cylinder operating	Single acting			Double acting		
Swivel stroke (mm)	12			15		
Clamping stroke (mm)	11			18		
Swivel angle	90°(60°,45°,0°)±2°					
Piston $\phi$ (mm)	25	32	40	25	32	40
Piston rod $\phi$ (mm)	18	22	25	18	22	25
Theoretical force (21 MPa)	495kg	890kg	1600kg	495kg	890kg	1600kg
A (unclamp) (mm)	127	127	127	134	133	134
A1 (unclamp) (mm)	131	131	131	138	137	138
B (mm)	102	97	98	102	97	98
B1 (mm)	106	101	102	106	101	102
C (mm)	70	74	76	70	74	76
D' (mm)	□19	□22	□25.4	□19	□22	□25.4
G (mm)	45	50	50	45	50	50
G' (mm)	100	120	140	100	120	140
K (mm)	9	10	12	9	10	12
L (mm)	ø8	ø8	ø10	ø8	ø8	ø10
N1 (clamp)/ N2 (unclamp) (mm)	Rc1/8	Rc1/8	Rc1/8	Rc1/8	Rc1/8	Rc1/8
O-ring manifold	P7	P7	P7	P7	P7	P7
N (mm)	M12×1.75	M12×1.75	M12×1.75	M12×1.75	M12×1.75	M12×1.75
P (mm)	50	54	66	50	54	66
P' (mm)	30	34	40	30	34	40
Q (mm)	64	68	84	64	68	84
Q' (mm)	46	54	64	46	54	64
R (mm)	ø6.5	ø8.5	ø8.5	ø6.5	ø8.5	ø8.5
S (mm)	M45×1.5	M50×1.5	M60×1.5	M45×1.5	M50×1.5	M60×1.5
T (×2 pcs) (mm)	10	11	11	10	11	11
T' (mm)	ø65	ø70	ø80	ø65	ø70	ø80
X (mm)	35	40	50	35	40	50
Y (mm)	23	27	32	23	27	32
Weight (kg)	1.5	1.9	2.9	1.5	1.9	2.9

# MF\* / MD\* Clamping arm

## HIGH OIL PRESSURE SWING CLAMP CYLINDER



mindman

### Clamping arm

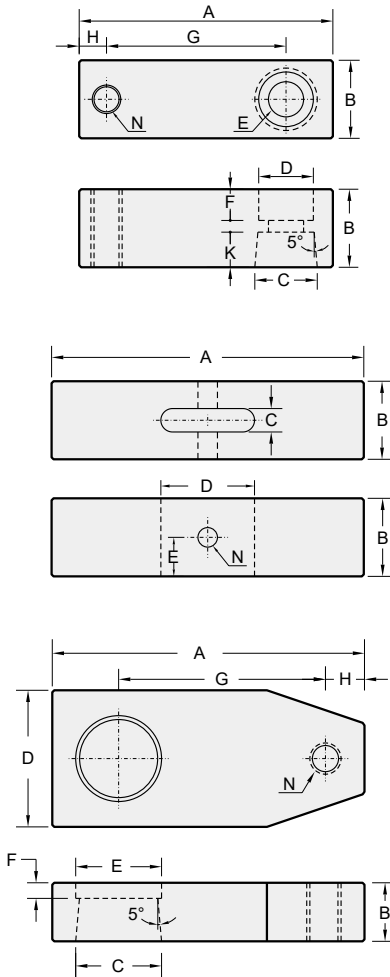

Unit: mm

Code Model	A	B	C	D	E	F	G	H	K	N
MAS-25	50	□16	14	11	7	6	30	8	6	M6
MAS-32 MATS-32 MAS-40 MATS-40	70	□19	16	14	9	7	50	9	9	M8
MHS-32 MHTS-32 MHS-40 MHTS-40 MHS-50 MHTS-50	80	□25	20	17	11	9	55	10	12	M10
MAS-50 MATS-50 MAS-63	95	□25	20	17	11	9	70	10	12	M10
MHS-25	74	□25	18	17	11	9	50	10	12	M10
MHS-63	103	□32	25	19	13	12	75	11	14	M12

Unit: mm

Code Model	A	B	C	D	E	N
MASD-32 MATSD-32 MHSD-25 MDS-25 MASD-40 MATSD-40 MDT-25	100	□19	9	30	9.5	8
MASD-50 MATSD-50 MHSD-32 MHTSD-32 MDS-32 MASD-63 MHSD-40 MHTSD-40 MDT-32 MHSD-50 MHTSD-50	120	□22	10	35	11	8
MHSD-63 MDS-40 MDT-40	140	□25	12	42	12.5	10

Unit: mm

Code Model	A	B	C	D	E	F	G	H	N
MFS-25, MFT-25	70	19	18	38	23	7	45	10	M12
MFS-32, MFT-32	78	19	22	38	25	7	50	10	M12
MFS-40, MFT-40	78	19	25	38	27	7	50	10	M12

### Flange type for manifold mounting with o-ring seal

Flange type dil cavity paths are reserved on square base type of hydraulic & high pressure cylinder, contently for fixture design.

Unit: mm

Code Model	A	B	O-ring
MHS-25	15	18	S4
MHS-32	17	24	S4
MHS-40	20	26	S4
MHS-50	25	30	S4
MHS-63	30	40	S4

Unit: mm

Code Model	X	Y	O-ring
MFS-25, MDS-25	35	23	S4
MFS-32, MDS-32	40	27	S4
MFS-40, MDS-40	50	32	S4

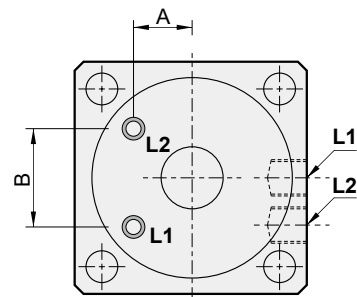

Top view

