

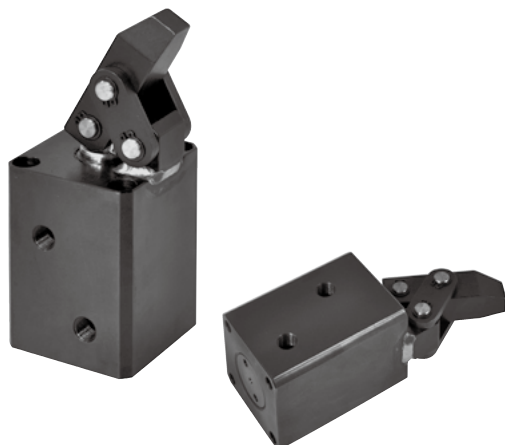

Caution for safety
(Read before installing)



MHCK

Standard type

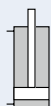

MHCK-F

Manifold type



Features

- Lever type clamp cylinder gives high clamping force.
- Manifold or freestanding model available.
- Carbon steel body ensures long life of unit.
- Ideal for use on CNC machine tools where repetitive clamping is required.

Specification

Model	MHCK				
Tube I.D. (mm)	25	32	40	50	63
Piston-rod (mm)	18	20	22.4	28	35
Standard stroke (mm)	25	25	30	35	40
Operating pressure range	0.5~5 MPa				
Proof pressure	7 MPa				
Clamping force (3 MPa)	1296N	2123N	3063N	4531N	6471N

Order example

MHCK – 25 – F

MODEL

TUBE I.D.

MANIFOLD TYPE



Blank: Standard type

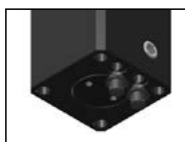

F: Manifold type

MHCK

MHCK-F

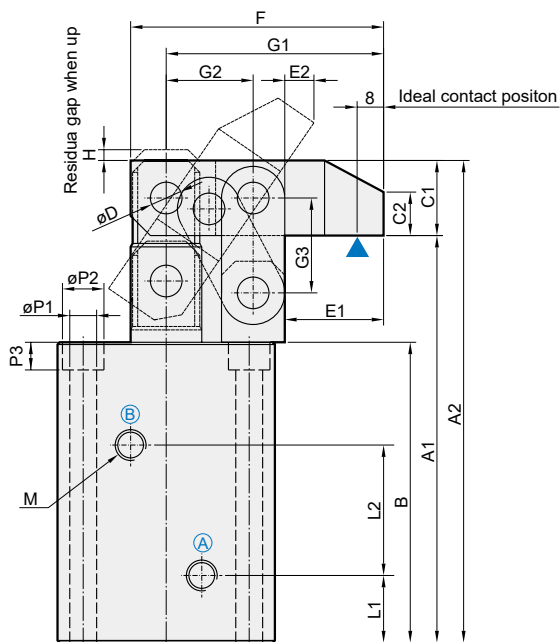
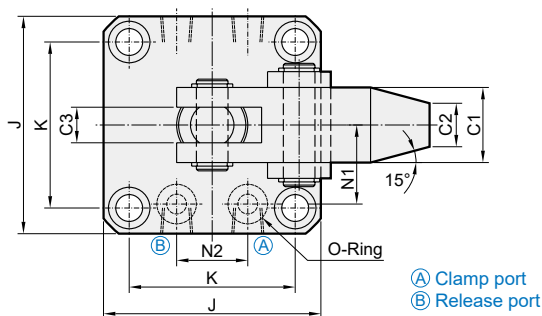

Code Tube I.D.	A1	A2	B	C1	C2	C3	D	E1	E2	F	G1	G2	G3	H	J
25	103	122	76	19	11	9	8	25	5	64	55	22	24	3	55
32	112	131	85	19	11	9	8	25	5	64	55	22	24	3	57
40	122	144.2	90	22.2	13	10	10	30	5.5	77	66	26	29	4	69
50	137	162.4	100	25.4	15	11	12	35.5	6.5	90	77	30	33	5	75
63	155	186.8	111	31.8	19	15	15	43	12.8	110	94	36	39	4	96

Code Tube I.D.	K	L1	L2	M	N1	N2	O	P1	P2	P3
25	42	17	33	Rc1/8	20	18	P7	6.8	10.5	7
32	44	19	38	Rc1/8	22	22	P7	6.8	10.5	7
40	52	19	40	Rc1/4	26	26	P8	9	14	9
50	58	21.5	45	Rc1/4	30	32	P8	9	14	9
63	75	22	52	Rc1/4	38	38	P9	11	18	11