



Technical data



Caution for safety
(Read before installing)



Features

- Hydro-pneumatic solution provides high power in confined space.
- Simple construction make these units ideal in many applications where previously hydraulics were the only option.
- Quiet in operation.
- Only requires a pneumatic valve to make the system operate.
- Wide range of working strokes and output forces available.

Specification

Model	MHPD
Pressure boost model	1T, 3T, 5T, 8T, 10T
Total stroke (mm)	50, 75, 100, 150, 200
Working stroke (mm)	5, 10, 15, 20
Medium	Filtered air with or without lubrication
Operating pressure range	0.3 ~ 0.8 MPa
Ambient temperature	-10~+60 °C (No freezing)

MHPD

Hole in rod end type



MHPD-Z

Male thread in rod end type

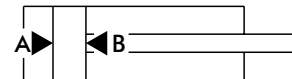

Order example

MHPD — 3T × 100 — 10 — Z

MODEL

THRUST MODEL

1T
3T
5T
8T
10T

TOTAL STROKE

50: 50mm
75: 75mm
100: 100mm
150: 150mm
200: 200mm

WORKING STROKE

5: 5mm
10: 10mm
15: 15mm
20: 20mm

ROD END TYPE



Blank: Hole



Z: Male thread

Power cylinders theoretic force

Unit: N

Thrust model		1T	3T	5T	8T	10T	
Tube I.D. (mm)		ø50	ø70	ø80	ø100	ø125	
Rod (mm)		ø30	ø40	ø50	ø60	ø70	
Operating pressure (MPa)	0.3	A	7,216	18,473	30,054	46,959	67,630
		B	377	778	919	1,508	2,527
	0.4	A	9,621	24,630	40,072	62,612	90,174
		B	503	1,037	1,225	2,011	3,369
	0.5	A	12,026	30,788	50,090	78,265	112,717
		B	628	1,296	1,532	2,513	4,212
	0.6	A	14,432	36,945	60,108	93,918	135,261
		B	754	1,555	1,838	3,016	5,054
	0.7	A	16,837	43,103	70,126	109,571	157,804
		B	880	1,814	2,144	3,519	5,896
	0.8	A	19,242	49,260	80,143	125,224	180,347
		B	1,005	2,073	2,450	4,021	6,739

1. Quick traverse

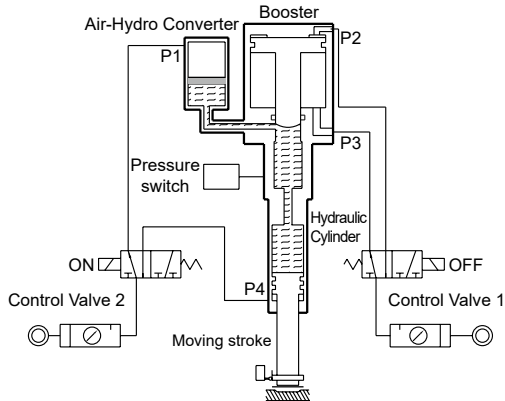

When the air is charged from the port P1, the oil in the tank will forward the hydraulic cylinder quickly. The pressure is the same as the air pressure, but the inflow of oil is large in volume.

2. Intensified feeding

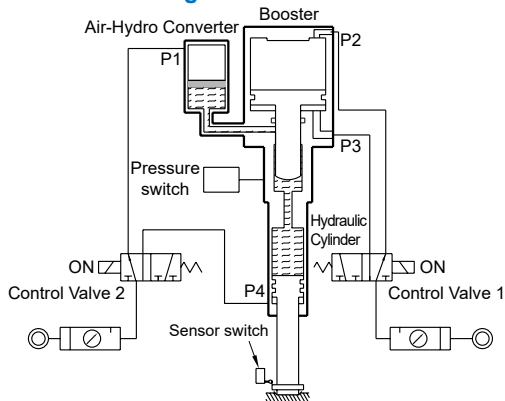

When the air is charged from the port P2, a ram will advance. the highly pressured fluid will come in to the hydraulic cylinder which will be forwarded by large thrust.

3. Swift reverse

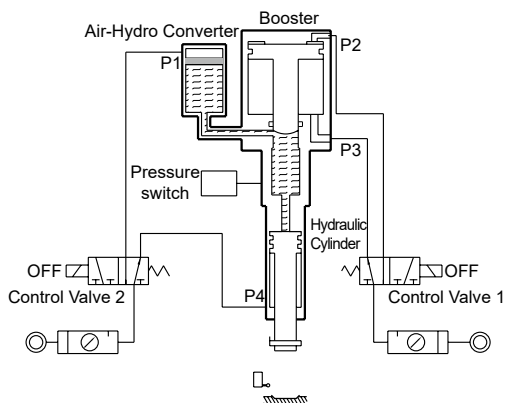

When the air is send into port P4 and P3. the hydraulic cylinder is swiftly reversed. and at the same time the ram goes back.

Points in usage

- The booster must be levelled. The booster must be higher than the work cylinder.
- Standard booster are designed for use with petroleum base hydraulic oil.
- Before working, the rod of booster and hydraulic must return.
- Frequency of use should be 20 times/min or lower.

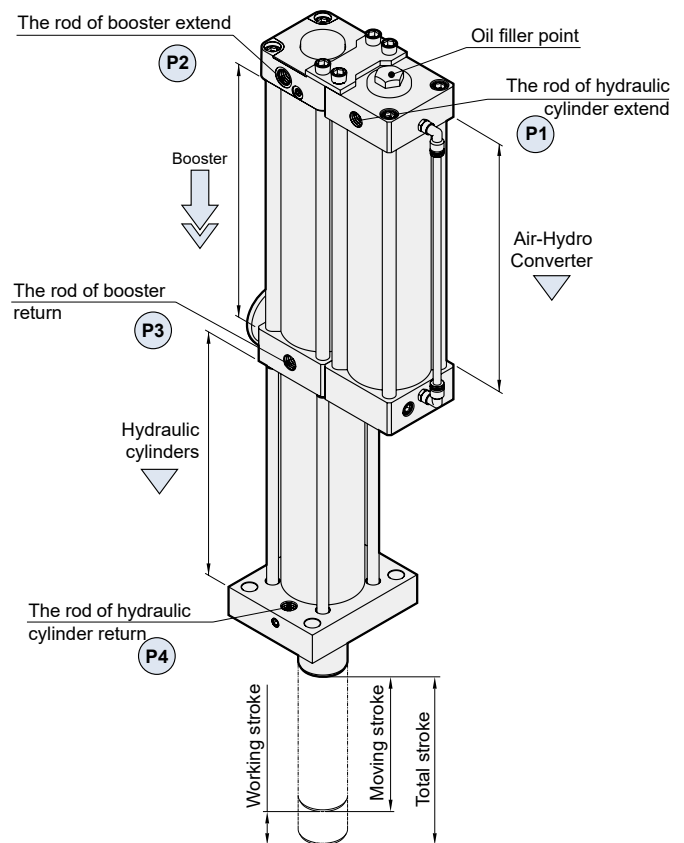

Power Cylinders bore and stroke

Type	Working stroke (mm)					
	1T	3T	5T	8T	10T	
MHPD	Thrust model					
	Total stroke					
	50mm	⑤⑩⑮	⑤⑩	⑤⑩	⑤⑩	⑤⑩⑮
	75mm	⑤⑩⑮⑳	⑤⑩⑮	⑤⑩⑮	⑤⑩⑮	⑤⑩⑮
	100mm	⑤⑩⑮⑳	⑤⑩⑮	⑤⑩⑮	⑤⑩⑮	⑤⑩⑮
	125mm	⑤⑩⑮⑳	⑩⑮	⑤⑩⑮	⑩⑮	⑩⑮⑳
MHPD-Z	50mm	⑤⑩⑮	⑤⑩	⑤⑩⑮	⑤⑩⑮	⑤⑩⑮
	75mm	⑤⑩⑮⑳	⑤⑩⑮	⑤⑩⑮	⑤⑩⑮	⑤⑩⑮⑳
	100mm	⑤⑩⑮⑳	⑤⑩⑮⑳	⑤⑩⑮	⑤⑩⑮⑳	⑤⑩⑮⑳
	125mm	⑤⑩⑮⑳	⑩⑮⑳	⑤⑩⑮⑳	⑩⑮⑳	⑩⑮⑳
	150mm	⑩⑮⑳	⑩⑮⑳	⑩⑮⑳	⑩⑮⑳	⑩⑮⑳
	200mm	⑩⑮⑳	⑩⑮⑳	⑩⑮⑳	⑩⑮⑳	⑩⑮⑳

Note. ⑤ = Working stroke 5mm, ⑩ = Working stroke 10mm;
⑮ = Working stroke 15mm, ⑳ = Working stroke 20mm;
Short stroke: ⑤⑩⑮⑳, Long stroke: ⑤⑩⑮⑳

MHPD / MHPD-Z

Standard stroke (Short stroke)

Type	Working stroke			
	5	10	15	20
1T	50~75	50~125	50~150	75~200
3T	50	50~100	75~150	150~200
5T	50~75	50~150	75~200	150~200
8T	50~75	50~150	75~200	150~200
10T	50	50~125	50~200	125~200
1T-Z	50~75	50~125	50~150	50~200
3T-Z	50	50~100	75~150	100~200
5T-Z	50~75	50~150	50~200	125~200
8T-Z	50~75	50~150	50~200	100~200
10T-Z	50	50~125	50~200	75~200

Working stroke

Type	W			
	5	10	15	20
1T	108	146	184	222
3T	126	187	248	309
5T	135	199	263	327
8T	150	214	278	342
10T	148	212	276	340

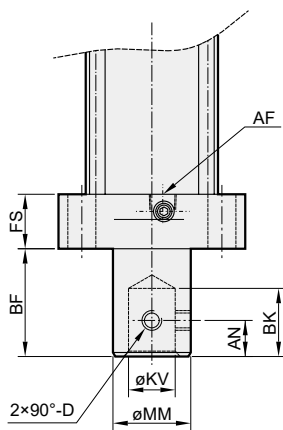

Female thread

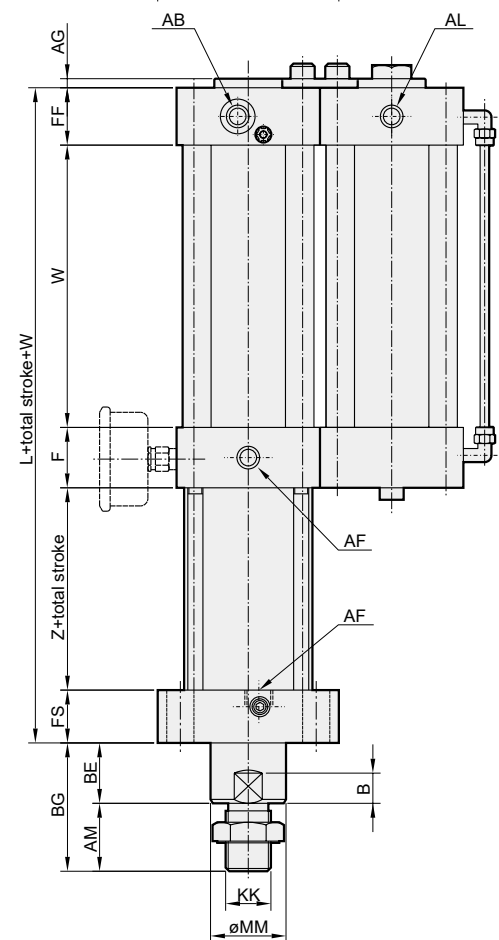
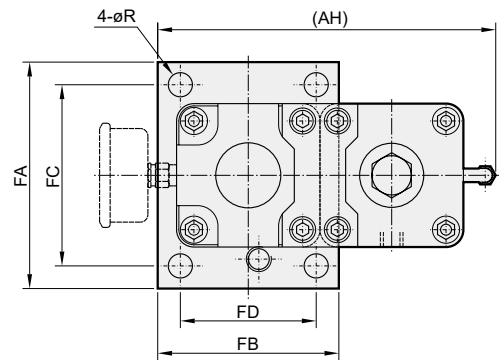
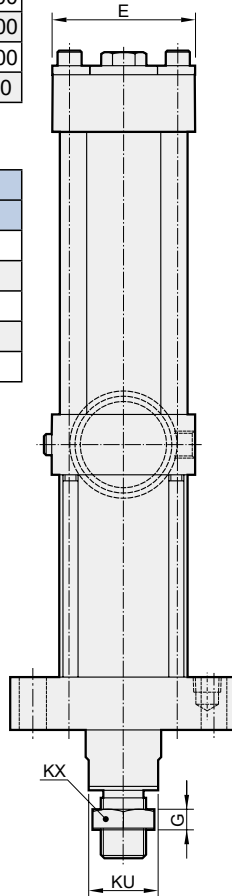

Code Type	AB	AF	AG	AH	AL	AM	AN	B	BE	BF	BG	BK	D	E	F
1T	G3/8	G3/8	5	187	G3/8	35	12	12	25	40	60	28	M6×1.0	75	40
3T	G3/8	G3/8	6	227	G3/8	45	15	20	40	50	85	35	M6×1.0	95	40
5T	G1/2	G1/2	6	262	G1/2	60	20	20	40	60	100	40	M10×1.5	115	40
8T	G1/2	G1/2	6	315	G1/2	70	25	20	50	70	120	60	M10×1.5	140	45
10T	G3/4	G3/4	6	381	G3/4	80	30	27	60	85	140	50	M10×1.5	174	55

Code Type	FA	FB	FC	FD	FF	FS	G	KK	KU	KV	KX	L	MM	R	Z
1T	130	100	100	70	32	35	11	M22×1.5	27	16	32	167	30	11	60
3T	150	120	120	90	38	35	13	M30×1.5	36	20	41	187	40	16	74
5T	185	130	155	100	40	45	15	M40×2.0	46	25	57	199	50	17	74
8T	230	160	190	120	45	45	15	M48×2.0	55	30	65	218	60	22	83
10T	270	190	220	140	55	50	20	M56×2.0	65	40	80	243	70	26	83

MHPD / MHPD-Z

Standard stroke (Long stroke)

Type	Working stroke		
	5	10	15
1T	80~125	130~200	155~200
3T	55~100	105~200	155~200
5T	80~125	155~200	–
8T	80~100	155~200	–
10T	75~100	130~200	–
1T-Z	80~125	130~200	155~200
3T-Z	55~100	105~200	155~200
5T-Z	80~125	155~200	–
8T-Z	80~100	155~200	–
10T-Z	55~100	130~200	–

Type	W		
	5	10	15
1T	108	146	184
3T	126	187	248
5T	135	199	263
8T	150	214	278
10T	148	212	276

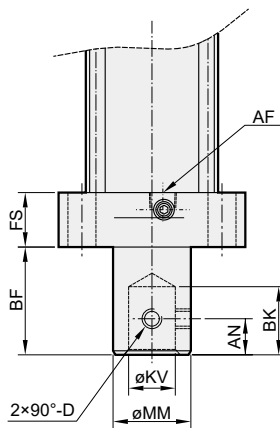

Female thread

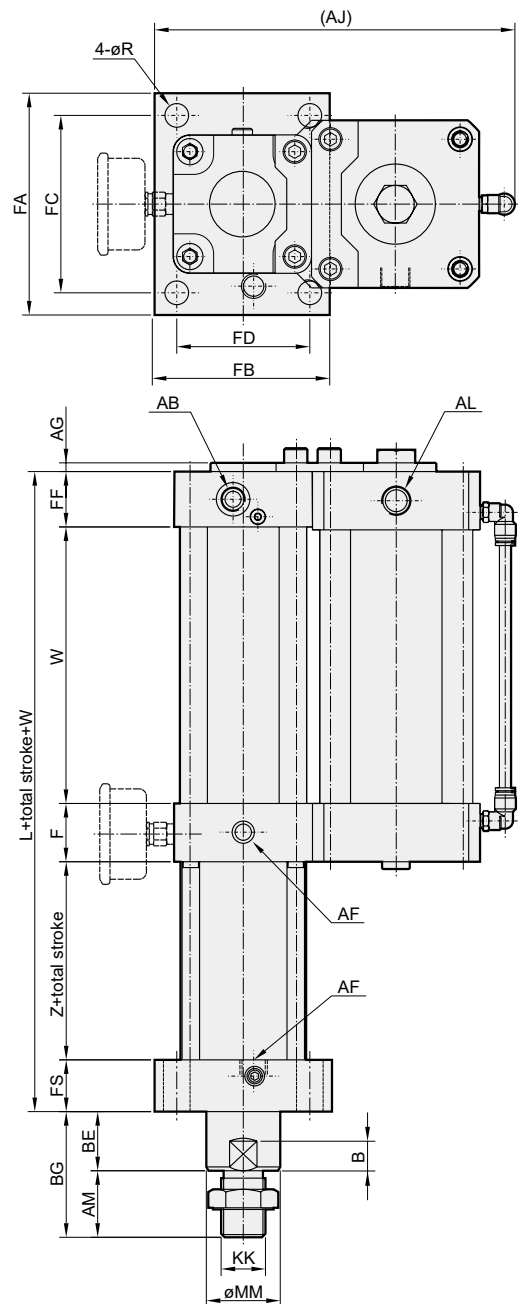
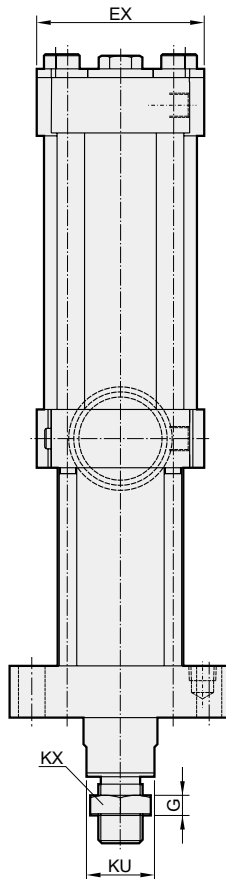

Code Type	AB	AF	AG	AJ	AL	AM	AN	B	BE	BF	BG	BK	D	EX	F
1T	G3/8	G3/8	5	207	G3/8	35	12	12	25	40	60	28	M6×1.0	95	40
3T	G3/8	G3/8	6	247	G1/2	45	15	20	40	50	85	35	M6×1.0	115	40
5T	G1/2	G1/2	6	287	G1/2	60	20	20	40	60	100	40	M10×1.5	140	40
8T	G1/2	G1/2	6	341	G3/4	70	25	20	50	70	120	60	M10×1.5	174	45
10T	G3/4	G3/4	6	411	G3/4	80	30	27	60	85	140	50	M10×1.5	204	55

Code Type	FA	FB	FC	FD	FF	FS	G	KK	KU	KV	KX	L	MM	R	Z
1T	130	100	100	70	32	35	11	M22×1.5	27	16	32	167	30	11	60
3T	150	120	120	90	38	35	13	M30×1.5	36	20	41	187	40	16	74
5T	185	130	155	100	40	45	15	M40×2.0	46	25	57	199	50	17	74
8T	230	160	190	120	45	45	15	M48×2.0	55	30	65	218	60	22	83
10T	270	190	220	140	55	50	20	M56×2.0	65	40	80	243	70	26	83