

Double acting

MTHS / MTHD

Single side clamping arm / Double sides clamping arm



Double acting (manifold type)

MTHS..FC / MTHD..FC

Single side clamping arm / Double sides clamping arm
(With flow control) (With flow control)



MTHS..F / MTHD..F

Single side clamping arm / Double sides clamping arm



MTHS..MF / MTHD..MF

Single side clamping arm / Double sides clamping arm



Features

- Compact design available with large range of bore sizes.
- Available with both clockwise and anti clockwise movement.
- Available with single or double arms.
- Available with inbuilt flow control.

Note

- Please don't exceed 1.5 times of the original length, if it is necessary to increase the length of the clamping arm.
- Suggested to install a flow control valve protect cylinder barrel and internal components against fretting wear

Specification

Model	MTHS, MTHD
Tube I.D. (mm)	25, 32, 40, 50, 63
Acting type	Double acting
Medium	Filtered oil
Operating pressure range	0.5~7 MPa
Proof pressure	10 MPa
Material of cylinder barrel	Carbon steel
Standard angle of rotation	90°±2° (Angles of 0°, 45° and 60° are optional)
Rotating direction	Clockwise or counter clockwise

Tube I.D.		25	32	40	50	63
Model						
MTHS	MTHD	○	○	○	○	○
MTHSL	MTHDL	×	○	○	○	○
MTHS-FC	MTHD-FC	○	○	○	○	○
MTHS-MF	MTHD-MF	○	○	○	○	○
MTHS-F	MTHD-F	○	○	○	○	×

Order example

MTHS L – 25 – CW – 90 – FC – B

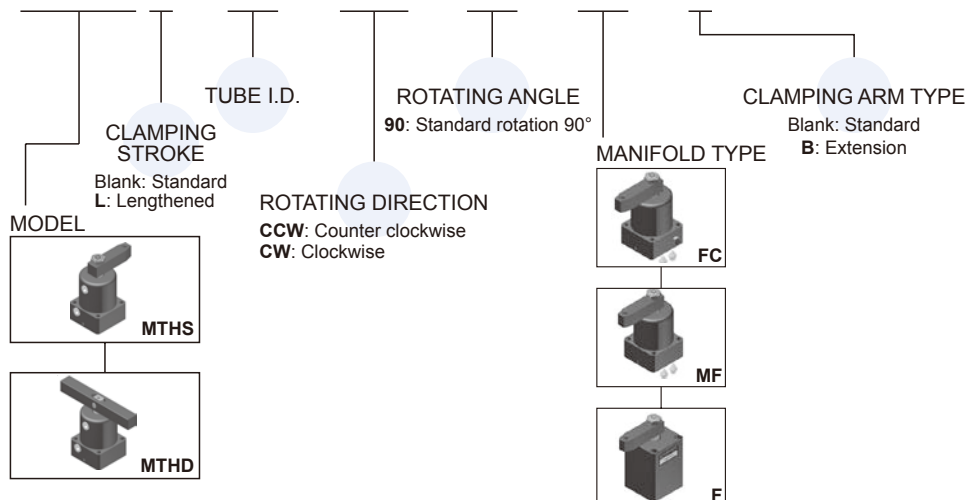

Single side swing clamp

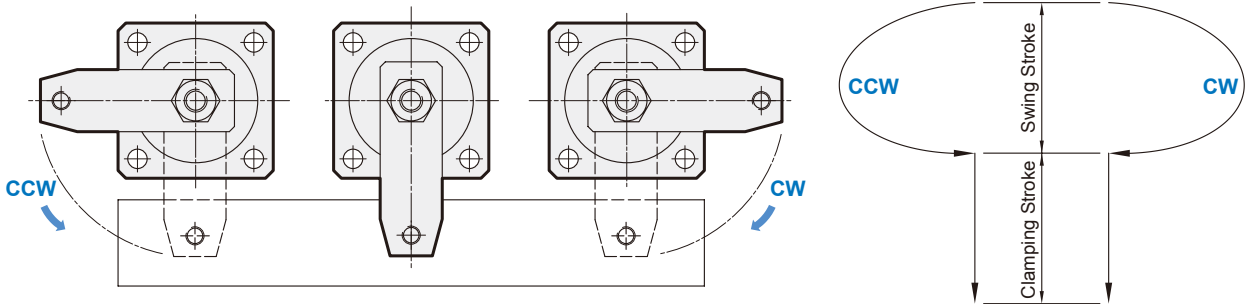

Double side swing clamp

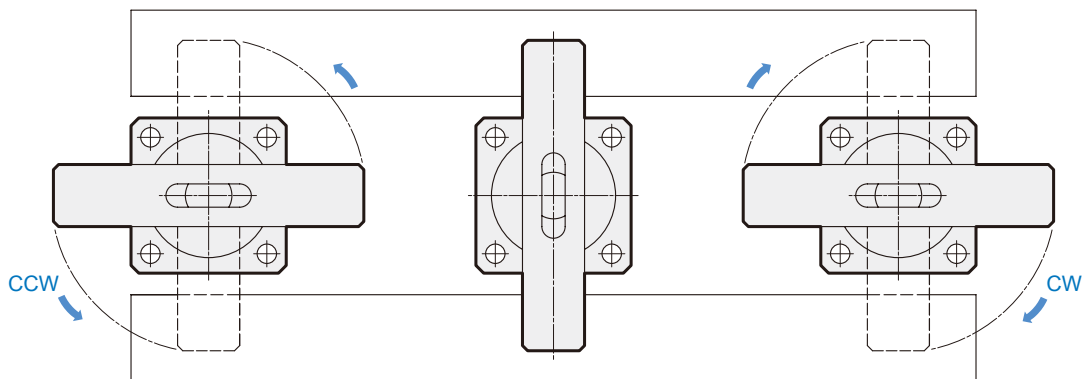

Clamping arm mounting methods



Clamping arm removing methods

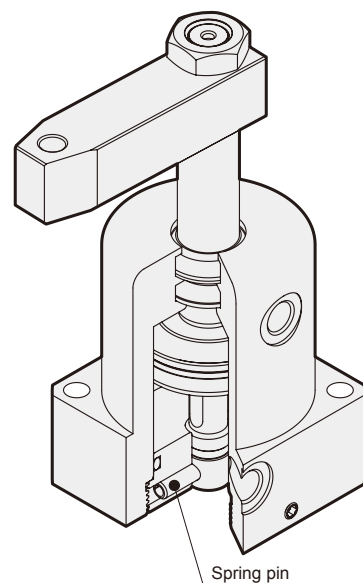
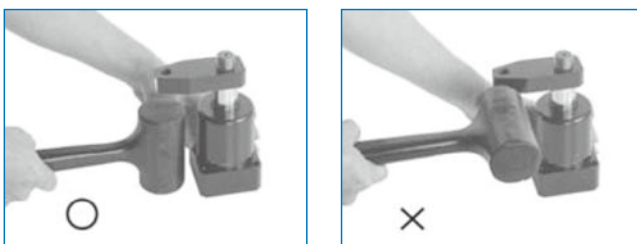

Note. If the clamping arm is wrong mounting and removing, the spring pin is broken easily. Then the rotation angle is deviation or the action is not smooth when the cylinder works.

MTHS / MTHSL

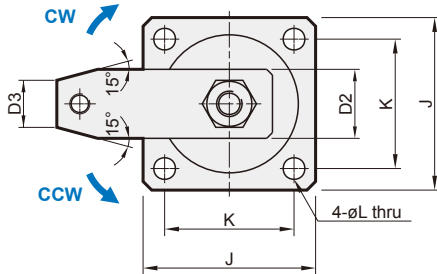

MTHD / MTHDL

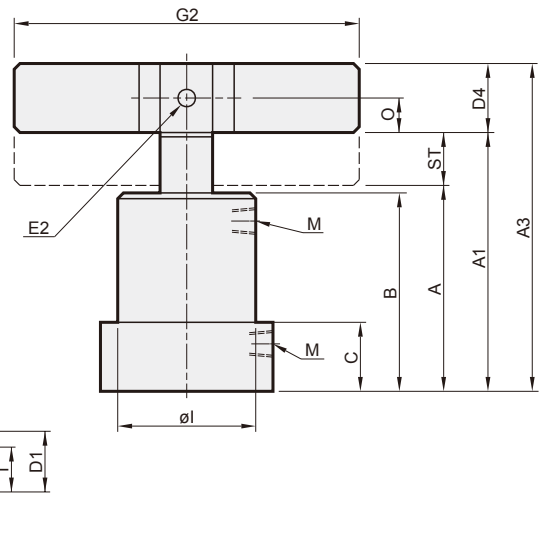
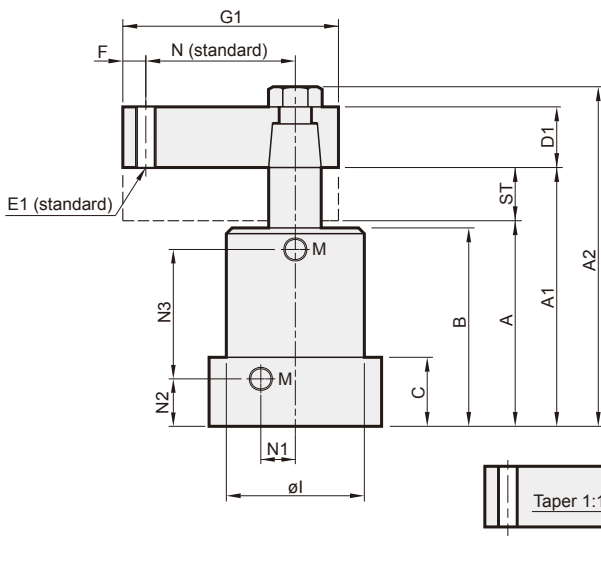
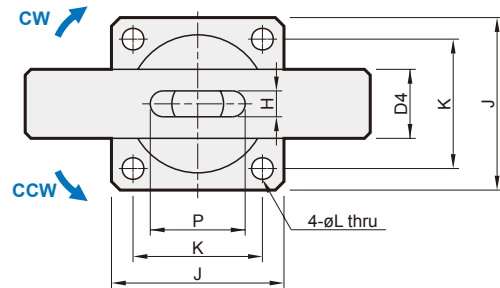

Single side clamping arm

ST: Stroke

* Clamping stroke lengthened type.

Model	Tube I.D. (mm)	Piston rod (mm)	Swing stroke (mm)	Clamping stroke (mm)		Pressure area push/pull (mm ²)	Clamping force (N) 3.5MPa	Clamping arm type				
				Standard	*			G1		G2		
								Standard	Extension	Standard	Extension	
MTHS-25	MTHD-25	ø25	ø18	9	13	—	491 / 237	830	74	100	140	200
MTHS-32	MTHD-32	ø32	ø20	11	15	30	804 / 490	1720	81	110	160	230
MTHS-40	MTHD-40	ø40	ø22.4	11	15	30	1257 / 863	3020	86	120	160	230
MTHS-50	MTHD-50	ø50	ø28	13	17	34	1963 / 1347	4710	96	130	180	260
MTHS-63	MTHD-63	ø63	ø35	13	17	34	3117 / 2155	7540	114	150	200	—

Code Model	Standard type						Clamping stroke lengthened type *						C	D1	D2	D3	D4	E1	E2	
	A	A1	A2	A3	B	ST	A	A1	A2	A3	B	ST								
MTHS-25	MTHD-25	79	101	124	120	76	22	—	—	—	—	—	—	27	15	27	15	□19	M10×1.5	ø8
MTHS-32	MTHD-32	89	115	140	137.2	85	26	104	145	170	167.2	100	41	30	17	31	17	□22.2	M10×1.5	ø8
MTHS-40	MTHD-40	94	120	148	142.2	90	26	109	150	178	172.2	105	41	30	18	31	17	□22.2	M10×1.5	ø10
MTHS-50	MTHD-50	104	134	166	159.4	100	30	121	168	200	193.4	117	47	34	20	37	19	□25.4	M12×1.75	ø12
MTHS-63	MTHD-63	109	139	175	170.8	105	30	126	173	209	204.8	122	47	34	23	48	24	□31.8	M16×2.0	ø15

Code Model	F	H	I	J	K	L	M	N	N1	N2	N3		O	P	R	S	T	
											Standard	*						
MTHS-25	MTHD-25	10	9	ø46	52	40	ø6.8	Rc1/8	50	8	17	46	—	9.5	25	ø15	ø18	13
MTHS-32	MTHD-32	10	10	ø50	56	44	ø6.8	Rc1/8	55	10	19	52	67	11.1	29	ø17	ø20	14
MTHS-40	MTHD-40	10	10	ø54	63	48	ø9	Rc1/8	60	12	19	57	72	11.1	31	ø19	ø22.4	15
MTHS-50	MTHD-50	12	12	ø66	72	57	ø9	Rc1/4	65	15	21.5	63.5	80.5	12.7	38	ø21	ø28	16
MTHS-63	MTHD-63	15	15	ø80	88	70	ø11	Rc1/4	75	17	22	68	85	15.9	48	ø27	ø35	18

MTH*-FC Manifold type (With flow control) $\phi 25 \sim \phi 63$



HYDRAULIC SWING CLAMP CYLINDER

Mindman

MTHS-FC

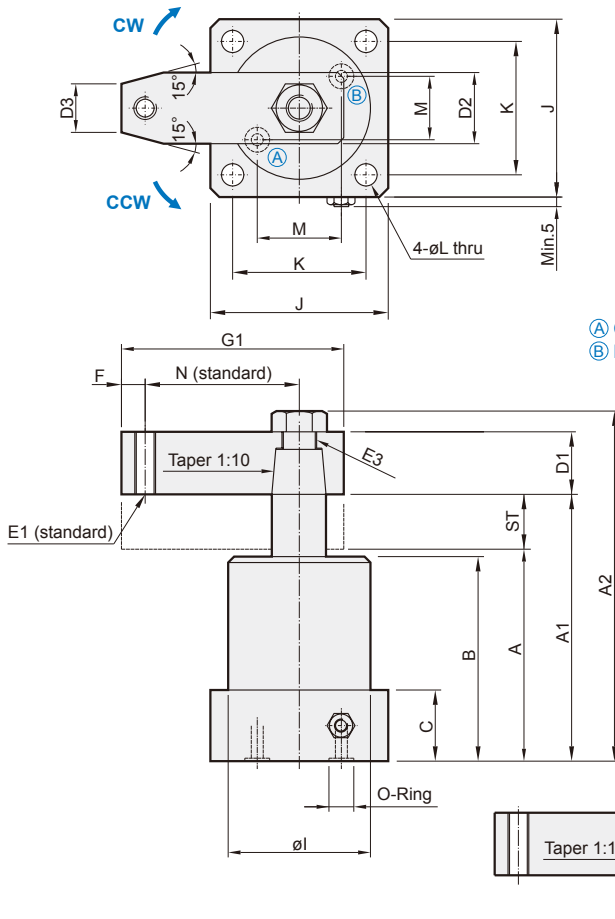

MTHD-FC

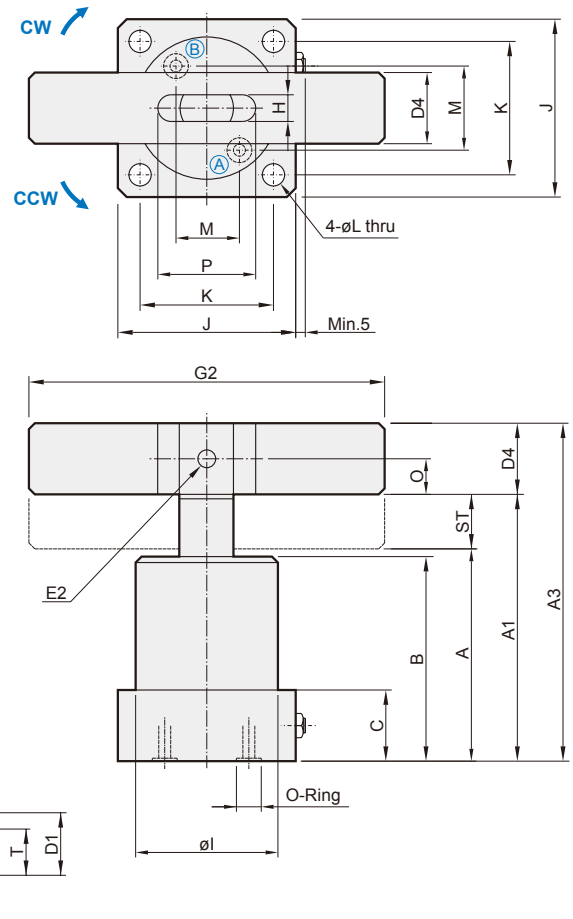

Single side clamping arm

ST: Stroke

Model	Tube I.D. (mm)	Piston rod (mm)	Swing stroke (mm)	Clamping stroke (mm)	Pressure area push/pull (mm ²)	Clamping force (N) 3.5MPa	Clamping arm type			
							G1		G2	
							Standard	Extension	Standard	Extension
MTHS-25FC	MTHD-25FC	$\phi 25$	$\phi 18$	9	491 / 237	830	74	100	140	200
MTHS-32FC	MTHD-32FC	$\phi 32$	$\phi 20$	11	804 / 490	1720	81	110	160	230
MTHS-40FC	MTHD-40FC	$\phi 40$	$\phi 22.4$	11	1257 / 863	3020	86	120	160	230
MTHS-50FC	MTHD-50FC	$\phi 50$	$\phi 28$	13	1963 / 1347	4710	96	130	180	260
MTHS-63FC	MTHD-63FC	$\phi 63$	$\phi 35$	13	3117 / 2155	7540	114	150	200	—

Code Model	ST	A	A1	A2	A3	B	C	D1	D2	D3	D4	E1	E2	E3	
MTHS-25FC	MTHD-25FC	22	79	101	124	120	76	22	15	27	15	$\square 19$	M10×1.5	$\phi 8$	M14×1.5
MTHS-32FC	MTHD-32FC	26	89	115	140	137.2	85	25	17	31	17	$\square 22.2$	M10×1.5	$\phi 8$	M16×1.5
MTHS-40FC	MTHD-40FC	26	94	120	148	142.2	90	25	18	31	17	$\square 22.2$	M10×1.5	$\phi 10$	M18×1.5
MTHS-50FC	MTHD-50FC	30	104	134	166	159.4	100	30	20	37	19	$\square 25.4$	M12×1.75	$\phi 12$	M20×1.5
MTHS-63FC	MTHD-63FC	30	109	139	175	170.8	105	30	23	48	24	$\square 31.8$	M16×2.0	$\phi 15$	M26×1.5

Code Model	F	G1	G2	H	I	J	K	L	M	N	O	O-Ring	P	R	S	T	
MTHS-25FC	MTHD-25FC	10	74	140	9	$\phi 46$	55	42	$\phi 6.8$	19	50	9.5	P7	25	$\phi 15$	$\phi 18$	13
MTHS-32FC	MTHD-32FC	10	81	160	10	$\phi 50$	57	44	$\phi 6.8$	21	55	11.1	P7	29	$\phi 17$	$\phi 20$	14
MTHS-40FC	MTHD-40FC	10	86	160	10	$\phi 54$	63	48	$\phi 9$	23	60	11.1	P9	31	$\phi 19$	$\phi 22.4$	15
MTHS-50FC	MTHD-50FC	12	96	180	12	$\phi 66$	72	57	$\phi 9$	28	65	12.7	P9	38	$\phi 21$	$\phi 28$	16
MTHS-63FC	MTHD-63FC	15	114	200	15	$\phi 80$	88	70	$\phi 11$	32	75	15.9	P9	48	$\phi 27$	$\phi 35$	18

MTHS-MF

MTHD-MF

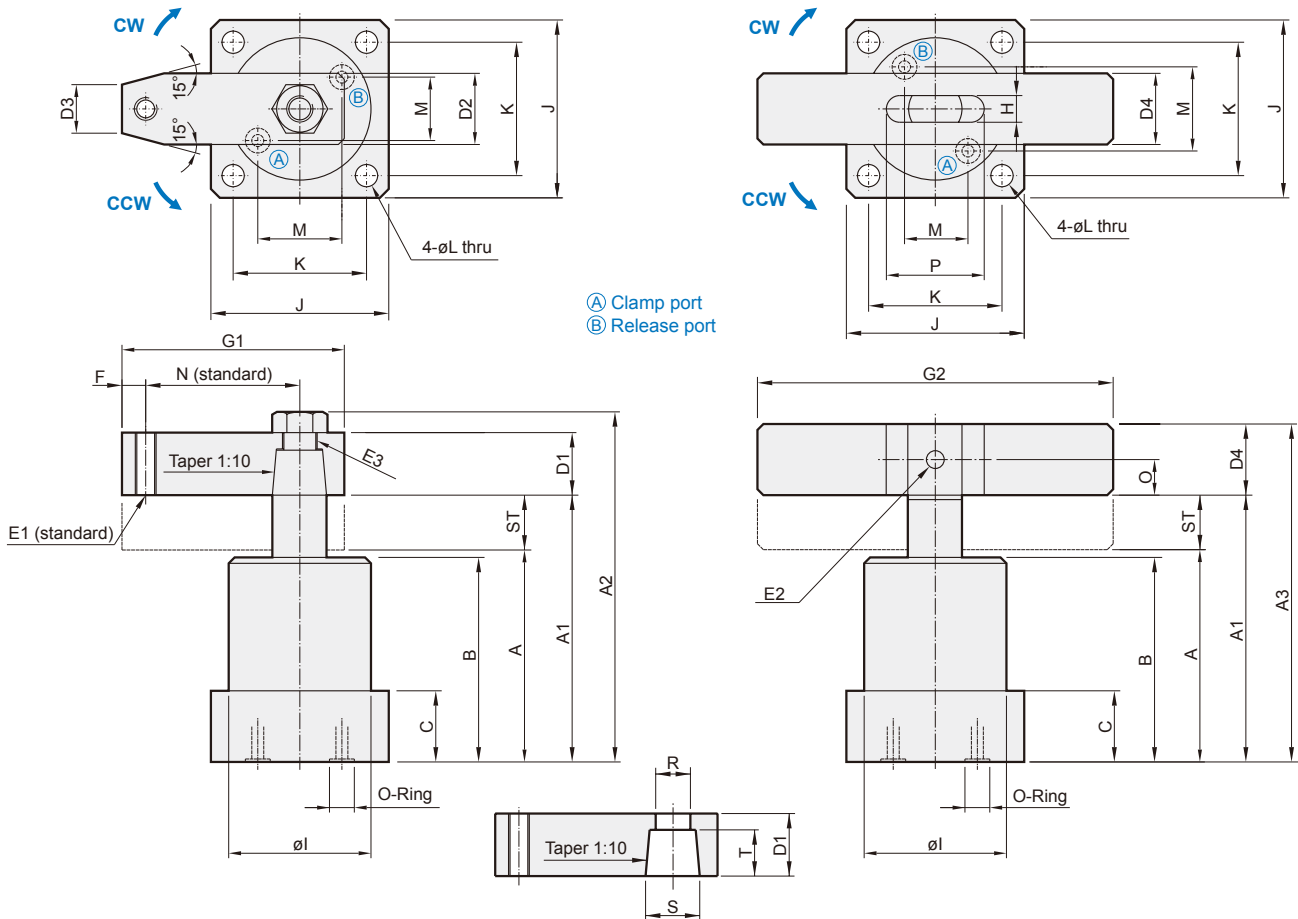

Single side clamping arm

ST: Stroke

Model		Tube I.D. (mm)	Piston rod (mm)	Swing stroke (mm)	Clamping stroke (mm)	Pressure area push/pull (mm ²)	Clamping force (N) 3.5MPa	Clamping arm type			
								G1		G2	
								Standard	Extension	Standard	Extension
MTHS-25MF	MTHD-25MF	$\phi 25$	$\phi 18$	9	13	491 / 237	830	74	100	140	200
MTHS-32MF	MTHD-32MF	$\phi 32$	$\phi 20$	11	15	804 / 490	1720	81	110	160	230
MTHS-40MF	MTHD-40MF	$\phi 40$	$\phi 22.4$	11	15	1257 / 863	3020	86	120	160	230
MTHS-50MF	MTHD-50MF	$\phi 50$	$\phi 28$	13	17	1963 / 1347	4710	96	130	180	260
MTHS-63MF	MTHD-63MF	$\phi 63$	$\phi 35$	13	17	3117 / 2155	7540	114	150	200	—

Code Model		ST	A	A1	A2	A3	B	C	D1	D2	D3	D4	E1	E2	E3
MTHS-25MF	MTHD-25MF	22	79	101	124	120	76	22	15	27	15	□19	M10×1.5	$\phi 8$	M14×1.5
MTHS-32MF	MTHD-32MF	26	89	115	140	137.2	85	25	17	31	17	□22.2	M10×1.5	$\phi 8$	M16×1.5
MTHS-40MF	MTHD-40MF	26	94	120	148	142.2	90	25	18	31	17	□22.2	M10×1.5	$\phi 10$	M18×1.5
MTHS-50MF	MTHD-50MF	30	104	134	166	159.4	100	30	20	37	19	□25.4	M12×1.75	$\phi 12$	M20×1.5
MTHS-63MF	MTHD-63MF	30	109	139	175	170.8	105	30	23	48	24	□31.8	M16×2.0	$\phi 15$	M26×1.5

Code Model		F	G1	G2	H	I	J	K	L	M	N	O	O-Ring	P	R	S	T
MTHS-25MF	MTHD-25MF	10	74	140	9	$\phi 46$	55	42	$\phi 6.8$	19	50	9.5	P7	25	$\phi 15$	$\phi 18$	13
MTHS-32MF	MTHD-32MF	10	81	160	10	$\phi 50$	57	44	$\phi 6.8$	21	55	11.1	P7	29	$\phi 17$	$\phi 20$	14
MTHS-40MF	MTHD-40MF	10	86	160	10	$\phi 54$	63	48	$\phi 9$	23	60	11.1	P9	31	$\phi 19$	$\phi 22.4$	15
MTHS-50MF	MTHD-50MF	12	96	180	12	$\phi 66$	72	57	$\phi 9$	28	65	12.7	P9	38	$\phi 21$	$\phi 28$	16
MTHS-63MF	MTHD-63MF	15	114	200	15	$\phi 80$	88	70	$\phi 11$	32	75	15.9	P9	48	$\phi 27$	$\phi 35$	18

MTHS-F

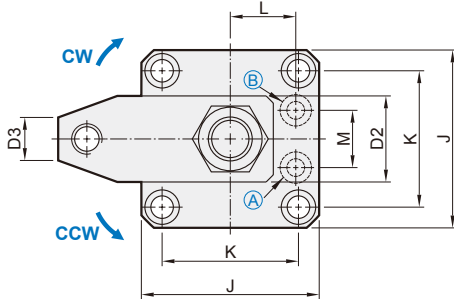

MTHD-F

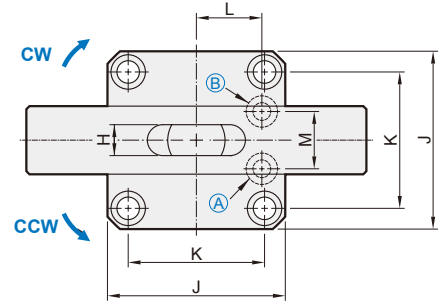

Ⓐ Clamp port
Ⓑ Release port

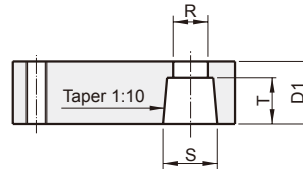
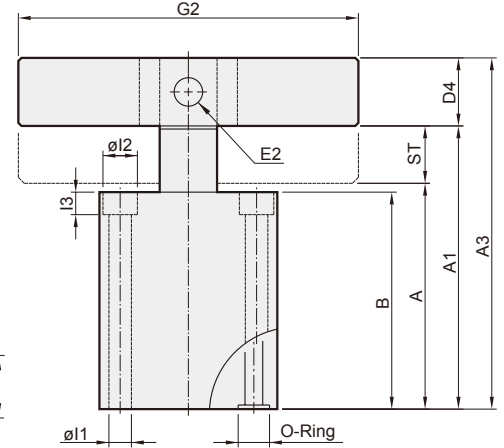
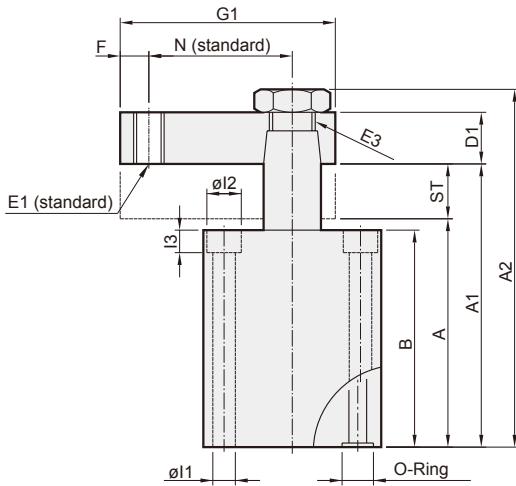

Single side clamping arm

ST: Stroke

Model		Tube I.D. (mm)	Piston rod (mm)	Swing stroke (mm)	Clamping stroke (mm)	Pressure area push/pull (mm ²)	Clamping force (N) 3.5MPa	Clamping arm type			
								G1		G2	
								Standard	Extension	Standard	Extension
MTHS-25F	MTHD-25F	$\varnothing 25$	$\varnothing 18$	9	13	491 / 237	830	74	100	140	200
MTHS-32F	MTHD-32F	$\varnothing 32$	$\varnothing 20$	11	15	804 / 490	1720	81	110	160	230
MTHS-40F	MTHD-40F	$\varnothing 40$	$\varnothing 22.4$	11	15	1257 / 863	3020	86	120	160	230
MTHS-50F	MTHD-50F	$\varnothing 50$	$\varnothing 28$	13	17	1963 / 1347	4710	96	130	180	260

Code Model		ST	A	A1	A2	A3	B	C	D1	D2	D3	D4	E1	E2	E3
MTHS-25F	MTHD-25F	22	79	101	124	120	76	22	15	27	15	$\square 19$	M10 \times 1.5	$\varnothing 8$	M14 \times 1.5
MTHS-32F	MTHD-32F	26	89	115	140	137.2	85	25	17	31	17	$\square 22.2$	M10 \times 1.5	$\varnothing 8$	M16 \times 1.5
MTHS-40F	MTHD-40F	26	94	120	148	142.2	90	25	18	31	17	$\square 22.2$	M10 \times 1.5	$\varnothing 10$	M18 \times 1.5
MTHS-50F	MTHD-50F	30	104	134	166	159.4	100	30	20	37	19	$\square 25.4$	M12 \times 1.75	$\varnothing 12$	M20 \times 1.5

Code Model		F	G1	G2	H	I1	I2	I3	J	K	L	M	N	O-Ring	R	S	T
MTHS-25F	MTHD-25F	10	74	140	9	$\varnothing 6.8$	$\varnothing 10.5$	7	55	42	20	18	50	P7	$\varnothing 15$	$\varnothing 18$	13
MTHS-32F	MTHD-32F	10	81	160	10	$\varnothing 6.8$	$\varnothing 10.5$	7	57	44	22	22	55	P7	$\varnothing 17$	$\varnothing 20$	14
MTHS-40F	MTHD-40F	10	86	160	10	$\varnothing 9$	$\varnothing 14$	9	69	52	26	26	60	P8	$\varnothing 19$	$\varnothing 22.4$	15
MTHS-50F	MTHD-50F	12	96	180	12	$\varnothing 9$	$\varnothing 14$	9	75	58	30	32	65	P8	$\varnothing 21$	$\varnothing 28$	16

Single side clamping arm (Standard type with thread)

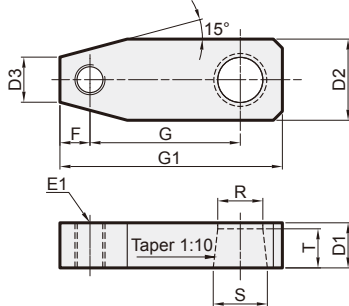

Code Model	D1	D2	D3	F	G	G1	E1	R	S	T
MTHS-25	15	27	15	10	50	74	M10×1.5	15	18	13
MTHS-32	17	31	17	10	55	81	M10×1.5	17	20	14
MTHS-40	18	31	17	10	60	86	M10×1.5	19	22.4	15
MTHS-50	20	37	19	12	65	96	M12×1.75	21	28	16
MTHS-63	23	48	24	15	75	114	M16×2.0	27	35	18

Single side clamping arm B type (Extension type without thread)

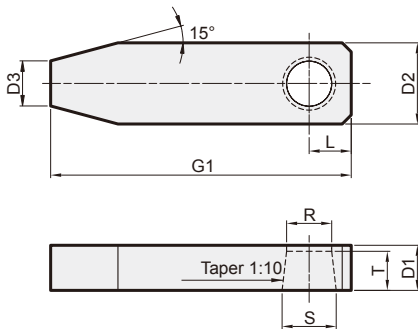

Code Model	D1	D2	D3	L	G1	R	S	T
MTHS-25 B	15	27	15	14	100	15	18	13
MTHS-32 B	17	31	17	16	110	17	20	14
MTHS-40 B	18	31	17	16	120	19	22.4	15
MTHS-50 B	20	37	19	19	130	21	28	16
MTHS-63 B	23	48	24	24	150	27	35	18

Double side clamping arm (Standard & Extension type)

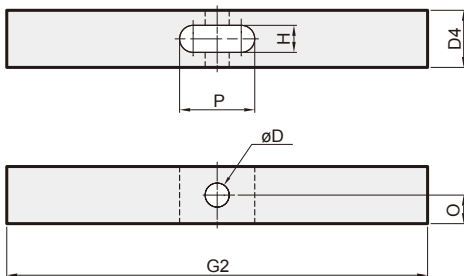

Double side clamping arm (Standard type)

Code Model	D	D4	O	P	H	G2
MTHD-25	$\varnothing 8$	$\square 19$	9.5	25	9	140
MTHD-32	$\varnothing 8$	$\square 22.2$	11.1	29	10	160
MTHD-40	$\varnothing 10$	$\square 22.2$	11.1	31	10	160
MTHD-50	$\varnothing 12$	$\square 25.4$	12.7	38	12	180
MTHD-63	$\varnothing 15$	$\square 31.8$	15.9	48	15	200

Double side clamping arm B type (Extension type)

Code Model	D	D4	O	P	H	G2
MTHD-25 B	$\varnothing 8$	$\square 19$	9.5	25	9	200
MTHD-32 B	$\varnothing 8$	$\square 22.2$	11.1	29	10	230
MTHD-40 B	$\varnothing 10$	$\square 22.2$	11.1	31	10	230
MTHD-50 B	$\varnothing 12$	$\square 25.4$	12.7	38	12	260

Cylinder weight

Model			Weight
MTHS-25	MTHS-25MF	MTHS-25FC	1.3
MTHD-25	MTHD-25MF	MTHD-25FC	1.5
MTHS-32	MTHS-32MF	MTHS-32FC	1.7
MTHD-32	MTHD-32MF	MTHD-32FC	2.0
MTHS-40	MTHS-40MF	MTHS-40FC	2.0
MTHD-40	MTHD-40MF	MTHD-40FC	2.3
MTHS-50	MTHS-50MF	MTHS-50FC	3.2
MTHD-50	MTHD-50MF	MTHD-50FC	3.5
MTHS-63	MTHS-63MF	MTHS-63FC	5.1
MTHD-63	MTHD-63MF	MTHD-63FC	5.7

Model	Weight	Model	Weight
MTHS-25F	1.8	MTHSL-32	2.4
MTHD-25F	2.0	MTHDL-32	2.7
MTHS-32F	2.2	MTHSL-40	2.8
MTHD-32F	2.5	MTHDL-40	3.1
MTHS-40F	3.3	MTHSL-50	4.5
MTHD-40F	3.5	MTHDL-50	4.8
MTHS-50F	4.3	MTHSL-63	7.1
MTHD-50F	4.65	MTHDL-63	7.7

Unit: kg