

MVBA series

BOOSTER REGULATOR



Features



Circuit example



Energy saving



Caution for safety
(Read before installing)



Symbol

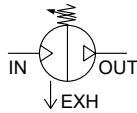

Order example

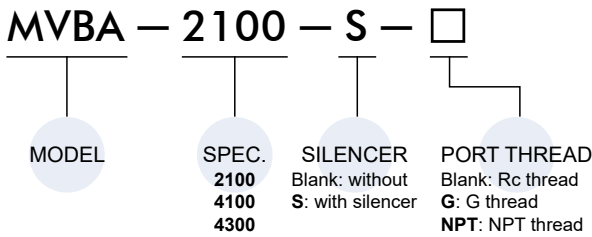

Working Principle

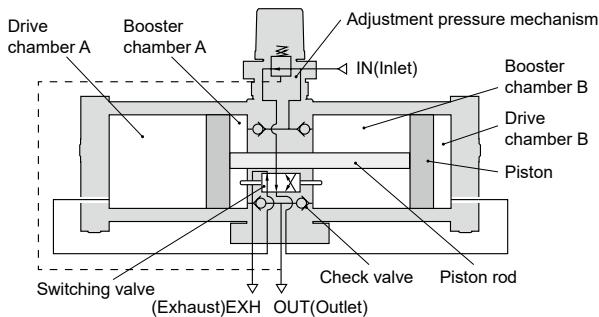

- The IN(Inlet) air passes through the check valve to booster chamber A and B. Meanwhile, air is supplied to drive chamber B via the governor and the switching valve. Then, the air pressure from drive chamber B and booster chamber A are applied to the piston, boosting the air in booster chamber B. As the piston travels, the boosted air is pushed via the check valve to the OUT(Outlet) side. When the piston reaches the switching valve to touch, so that drive chamber B is in the exhaust state and drive chamber A is in the supply state respectively. Then, the piston reverses its movement, this time, the pressures from booster chamber B and drive chamber A boosts the air in booster chamber A and sends it to the OUT side.
- The process described above is repeated to continuously supply highly pressurized air from the IN to the OUT side. The governor establishes the outlet pressure by handle operation and pressure adjustment in the drive chamber by feeding back the outlet pressure.

Features

- Increase factory air pressure by up to twice as much.
- Air-only operation requires no power supply, reduces heat generation, and allows easy installation.

Caution

- It is recommended to install a mist separator (0.3μm) at the inlet side of the booster regulator.

Specification

Model	MVBA-2100	MVBA-4100	MVBA-4300
Port size (IN, OUT, EXH) (*1)	3/8	1/2	1/2
Gauge port (IN, OUT) (*1)	1/16	1/8	1/8
Air tank port (*1)	1/4	1/2	1/2
Medium	Compressed air		
Pressure increase rate	Maximum of twice		
Operating pressure range (*2)	0.2~1 MPa		0.2~1.6 MPa
Supply pressure range	0.1~1 MPa		
Proof pressure	1.5 MPa		2.4 MPa
Max. flow rate (*3)	1000 ℓ/min	1600 ℓ/min	
Ambient temperature	+2~+50°C (No freezing)		
Installation	Horizontal		
Lubrication	Not required		
Attachment: Pressure gauge	PG-25	PG-40W	PG-40W-20K
Option: Silencer (S)	MSLT-03	MSLT-04	
Suitable for air tank (Please refer to the MVBA series)	MVBAT10A	MVBAT21C	MVBAT22HC
	MVBAT20A		
	MVBAT21B		
Weight (kg)	3.9	9.4	9.5

*1. Thread type combination

Model	Port thread	Gauge thread	Air tank thread
MVBA-2100	Rc, G, NPT	Rc	Rc
MVBA-4100	Rc, G	Rc	Rc
MVBA-4300	NPT	NPT	Rc

*2. Do not adjust the pressure beyond the maximum specified pressure range.

*3. Max. flow rate at IN=OUT=0.5 MPa.

*4. Attachment and optional accessories are included with the shipment separately and are not pre-assembled.

Caution

- If the outlet capacity is undersized, pulsation may occur.
- Make sure to install a mist separator at the inlet side of the booster regulator.
- The booster regulator has a sliding part inside, and it generates dust. Also, install a cleaning device such as an air filter or a mist separator on the outlet side as necessary.
- Provide a dedicated pipe to release the exhaust air from each booster regulator. If exhaust air is converged into a pipe, the back pressure that is created could cause improper operation.
- Depending on the necessity, install a silencer on the exhaust port of the booster regulator to reduce the exhaustion sound.
- Allow the sufficient space for maintenance and inspection.

Example of circuit usage

- In factories where only specific equipment requires high pressure, a booster cylinder can be installed in the corresponding local air circuit. This allows the overall air circuit to maintain low pressure while enabling the use of high-pressure equipment in localized areas. This design not only reduces the pressure demand on the overall air circuit but also effectively saves energy and decreases the load on the equipment.

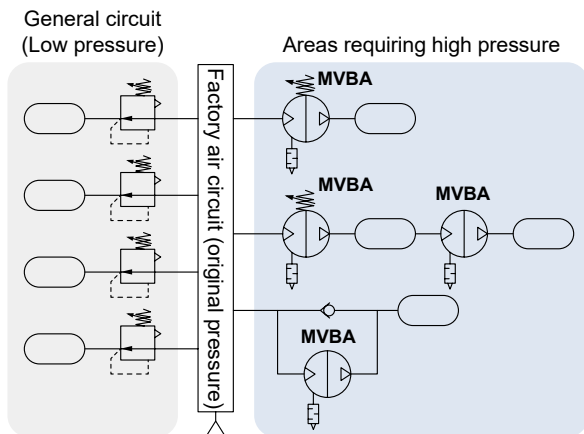

- When the actuator's output force is insufficient and spatial constraints prevent the use of a larger cylinder, a booster cylinder can be employed to increase output force without replacing the existing actuator.
- In cases where miniaturization of the drive component is required, and a small cylinder size is needed while maintaining a high output force, a booster cylinder offers an effective solution.

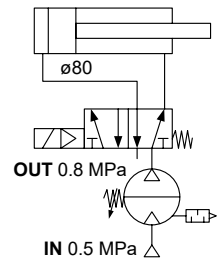
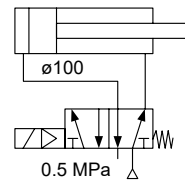

Operating Pressure	0.5 MPa
Tube I.D.	ø100 mm
Output Force	3850 N

Equivalent output force

Operating Pressure	0.8 MPa
Tube I.D.	ø80 mm
Output Force	4000 N

- When using two booster cylinders for two-stage boosting, ensure that each booster cylinder is supplied with sufficient airflow to maintain the stability of the inlet pressure at the booster valve. This is critical for ensuring the stability and efficiency of the boosting process.

- During the process of charging the air tank, a circuit design incorporating a booster cylinder in parallel with a check valve is used. When the pressure in the air tank is lower than the inlet air source pressure, the air source directly charges the tank through the check valve. This method efficiently utilizes the air source pressure, reducing the charging time and improving overall efficiency.

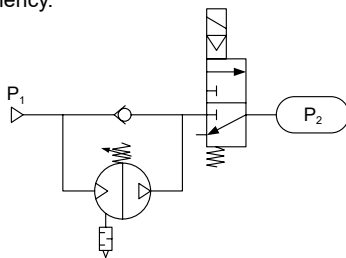

The inlet pressure (P_1) first passes through a check valve to charge P_2 until $P_1 = P_2$.

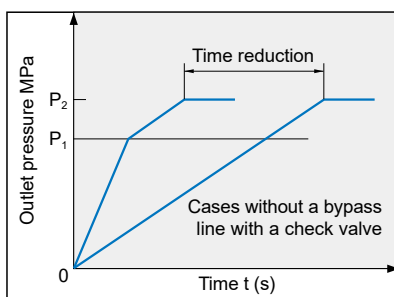

- For single-acting cylinder operations, installing a booster cylinder in the corresponding air supply circuit can reduce compressed air consumption, achieving more efficient operation.

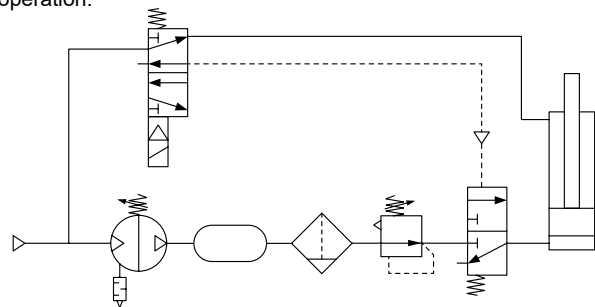

Flow features

MVBA-2100

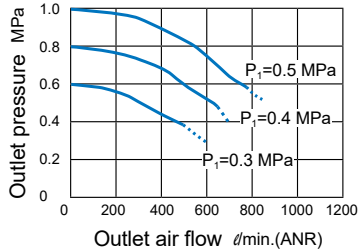

MVBA-4100

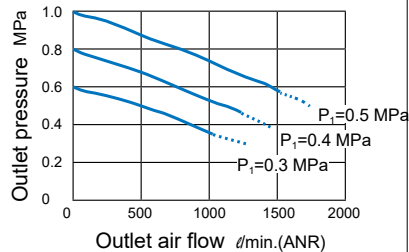

MVBA-4300

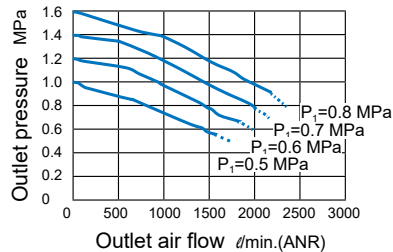

Pressure characteristics

Inlet pressure 0.7 MPa
Output pressure 1.0 MPa
Flow rate: 20L/min(ANR)

MVBA-2100

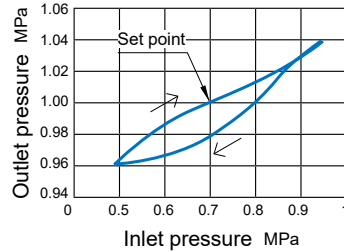

Inlet pressure 0.7 MPa
Output pressure 1.0 MPa
Flow rate: 20L/min(ANR)

MVBA-4100

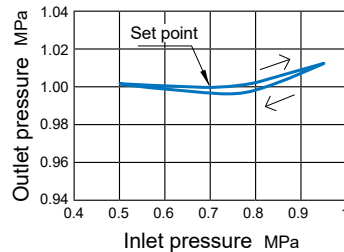

Inlet pressure 0.7 MPa
Output pressure 1.0 MPa
Flow rate: 20L/min(ANR)

MVBA-4300

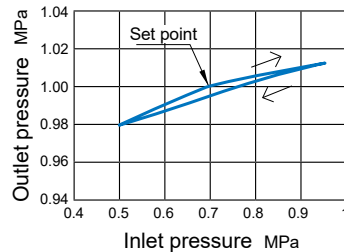

Charge test

MVBA-2100

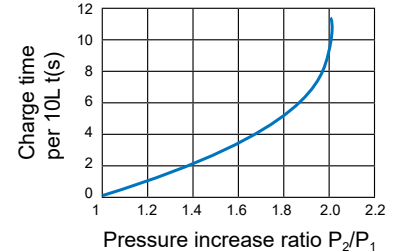

MVBA-4100

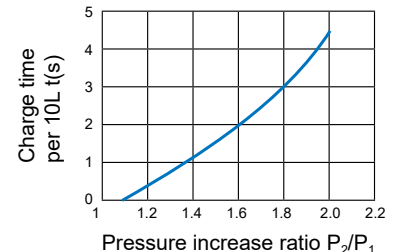

MVBA-4300

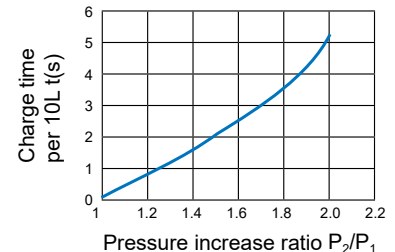

Calculation method for air tank charge time

P_0	Primary side air pressure
P_1	Air pressure in tank before filling
P_2	Air pressure in tank after filling
$K_1 = P_1/P_0$	Boosting ratio before filling
$K_2 = P_2/P_0$	Boosting ratio after filling

Find K_1 and K_2 at first, then read filling time t_1 and t_2 according to graph where boosting ratio K_1 , K_2 . Finally filling time for tank capacity Q is obtained with

$$T = \frac{Q}{10} (t_2 - t_1).$$

(Each characteristics are just reference, but not assured conditions)

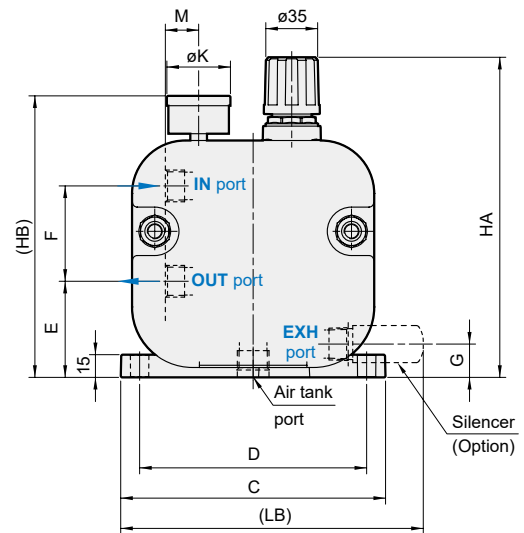
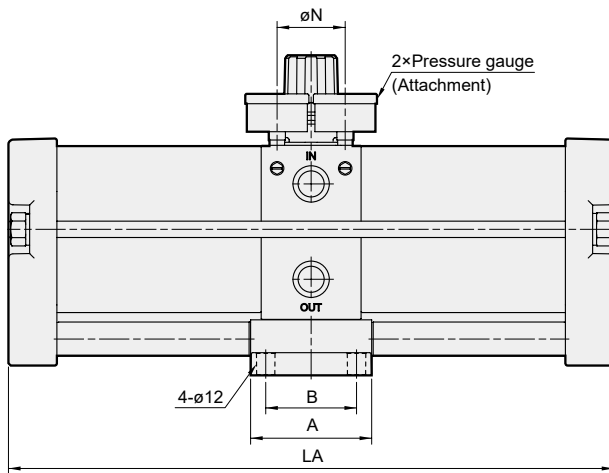
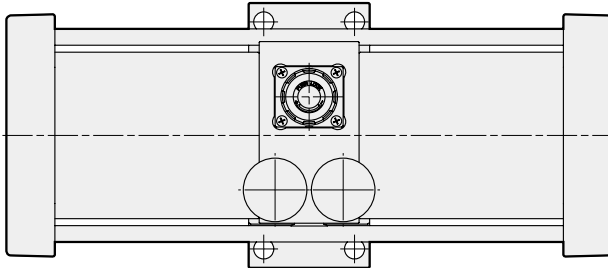

Back

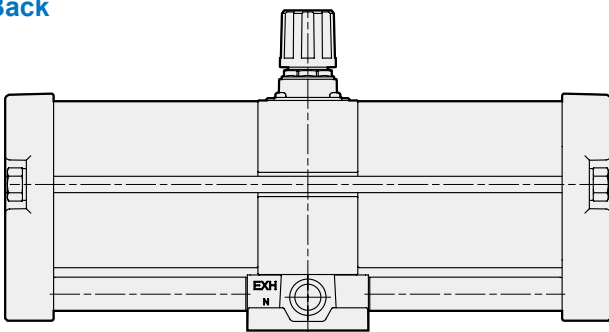

Code Model	A	B	C	D	E	F	G	HA	HB	LA	LB	K	M	N
MVBA-2100	73	53	118	98	46	43	18	172.5	140	295	168	24	8	30
MVBA-4100	80	60	175	150	63.5	63	22	211.5	186	400	200	42	22	45
MVBA-4300								221.8						