

MVHF-LB

MOUNTING BRACKET



Specification

Model	MVHF-LB
Type	90° angle, heavy duty mounting bracket for clippard miniature valves.
Mounting	1/2" diameter hole for valve, two (2) 0.261" diameter holes for attaching bracket.
Construction	Stamped from 1/8" thick steel, zinc plated.
Weight	40 g

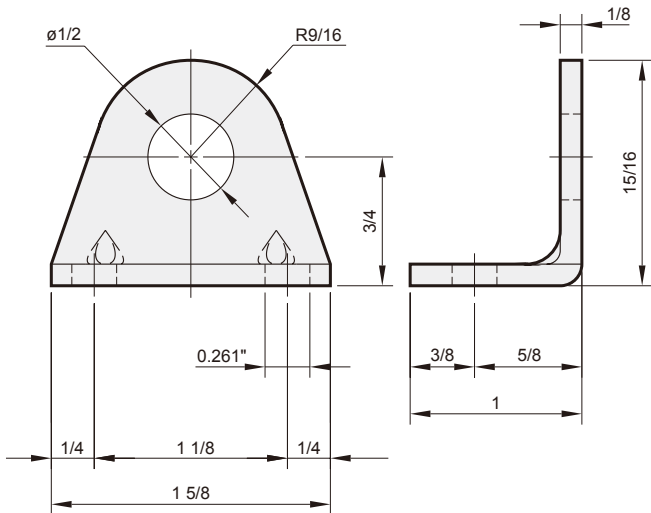

MVHF-PB*

VALVE ACTUATORS MANUAL PUSH BUTTON



Specification

Model	MVHF-PB2	MVHF-PB5
Type	Round, aluminum products prevents over travel of valve stem by providing a positive stop.	
Use	Mounts directly on valve stem for manual operation of valve. Prevents over travel of valve stem by providing a positive stop.	
Mounting	1/8" dia. mounting hole fits valve stems, locks in place by set screw. (Allen wrench furnished)	
Note	Individually packaged or bulk quantities available.	
Weight	7 g	6 g

MVHF-PB2

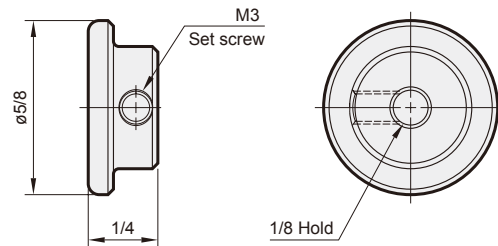

MVHF-PB5

