

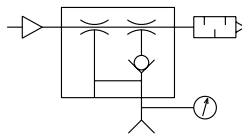

Symbol



Order example

MVVZA - 15 - 2 - G

MODEL

NOZZLE DIA.

15: 1.5mm

NOZZLE NUMBER

2: 2 sets

4: 4 sets

DIGITAL VACUUM GAUGE

Blank: None
G: With gauge

Dimensions

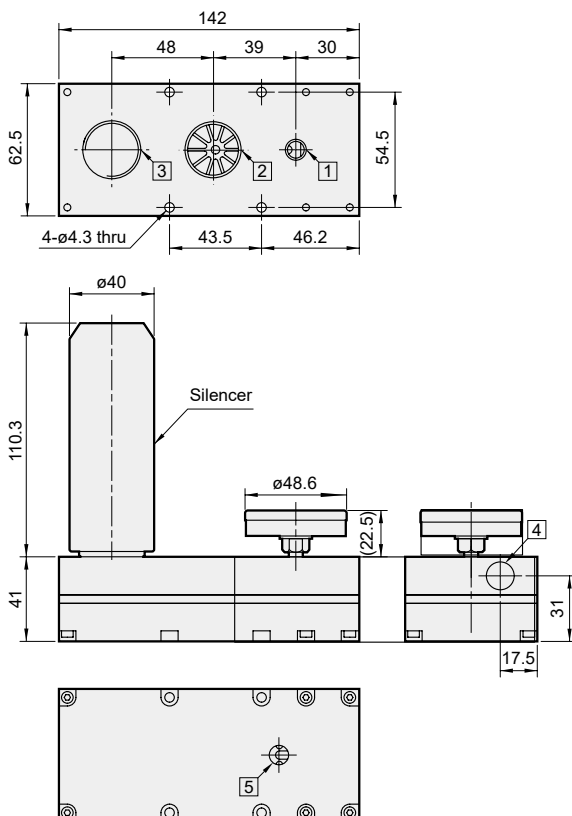

Specification

Model	MVVZA	
Nozzle number	2	4
Nozzle dia.	1.5 mm	
Port size	Please refer to dimensions	
Medium	Air	
Operating pressure range	0.1~0.6 MPa	
Ambient temperature	0~+60°C (No freezing)	
Final vacuum	-92 kPa (-690 mmHg)	
Suction flow	350 L/min	500 L/min
Air consumption	310 L/min	550 L/min
Supply pressure	0.6 MPa	
Lubrication	Not required	
Weight	775 g	826 g

Flow features

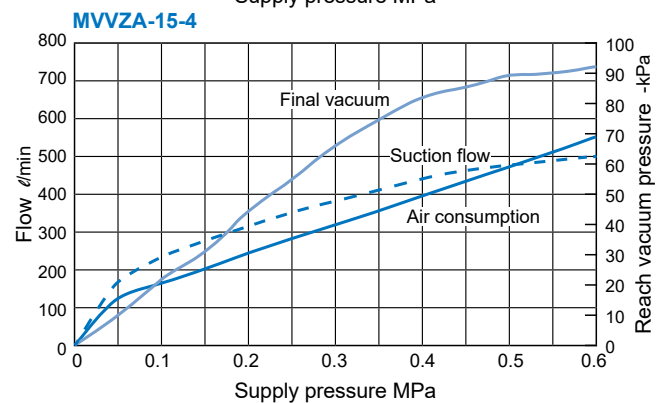
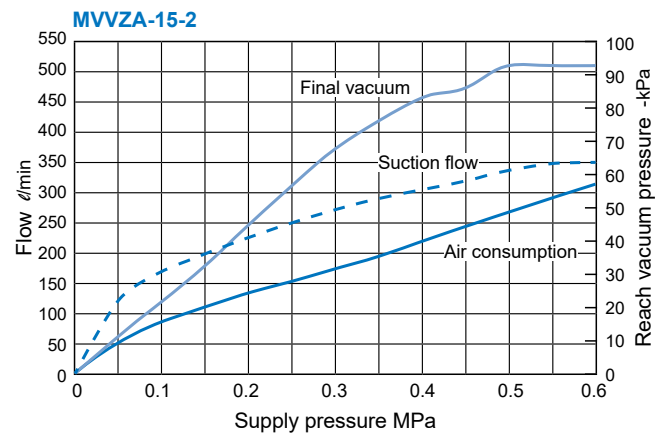

No.	Part name	Nozzle number	
		2 sets	4 sets
1	Vacuum display interface	PS1/8"	PS1/8"
2	Vacuum suction port	PS3/4"	PS3/4"
3	Exhaust port	PS3/4"	PS3/4"
4	Inlet port	PS1/4"	PS1/4"
5	Vacuum suction backup port	PS1/8"	PS1/8"

MVVZA Vacuum gauge operating instructions

VACUUM GENERATOR

