

MZL212 series

MULTISTAGE VACUUM PUMP

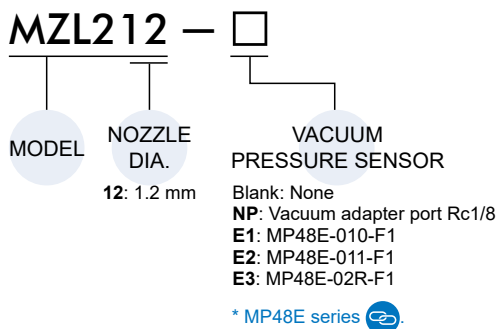

Order example



Features

- Adopt 3-stage cartridge, enhancing vacuum flow and saving air consumption.
- Optional solenoid valve and vacuum pressure switch.
- Internal vacuum filter and vacuum silencer. The filter element is replaceable.
- A variety of installation directions are available.

Specification

Model	MZL212
Nozzle dia.	1.2 mm × 2
Max. suction flow	200 ℓ/min
Air consumption	126 ℓ/min
Max. vacuum pressure	-84 kPa
Max. operating pressure	0.7 MPa
Supply pressure range	0.2~0.5 MPa
Standard supply pressure	0.4 MPa
Operating temperature range	+5~+50°C
Noise	77 decibel
Weight	700 g

Vacuum flow(ℓ/min) at different vacuum levels (-kPa)

Supply pressure	Air consumption	Vacuum flow(ℓ/min) at different vacuum levels (-kPa)										Max. vacuum level
		0	10	20	30	40	50	60	70	80		
0.4 MPa	126 ℓ/min	0	10	20	30	40	50	60	70	80	-84 kPa	
		200	150	52	40	30	25	15	8	3		

Evacuation time(s/ℓ) to reach different vacuum levels (-kPa)

Supply pressure	Air consumption	Evacuation time(s/ℓ) to reach different vacuum levels (-kPa)										Max. vacuum level
		10	20	30	40	50	60	70	80			
0.4 MPa	126 ℓ/min	0.02	0.08	0.25	0.42	0.65	0.98	1.52	2.46	-84 kPa		
		10	20	30	40	50	60	70	80			

Vacuum characteristics

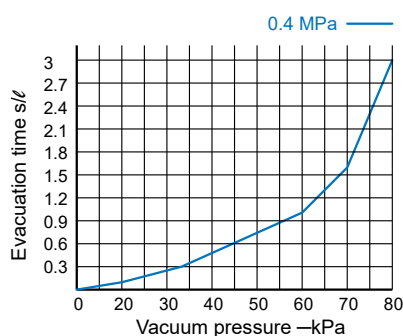
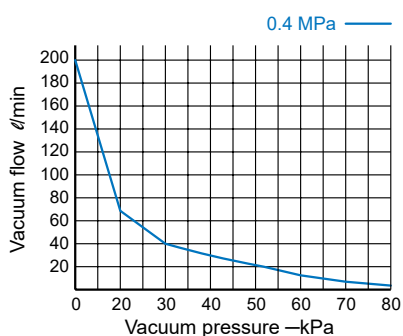

MZL212 Dimensions

MULTISTAGE VACUUM PUMP



MZL212

Standard

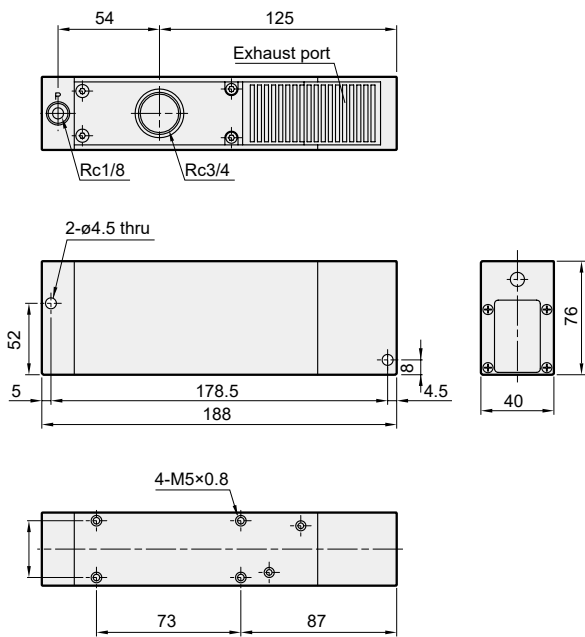

MZL212-NP

Vacuum adapter port

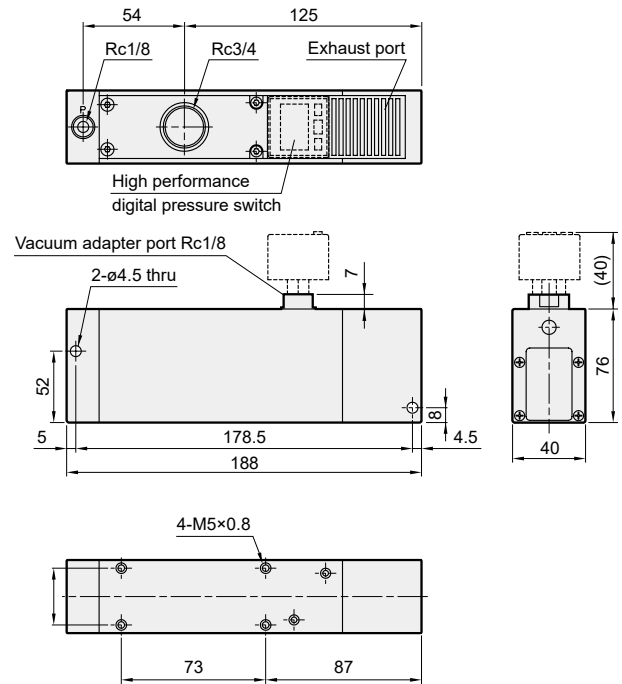

MZL212-E*

With high performance digital pressure switch