

# TLG30S series

PNEUMATIC SANDER – LINEAR COMPLIANT TOOL

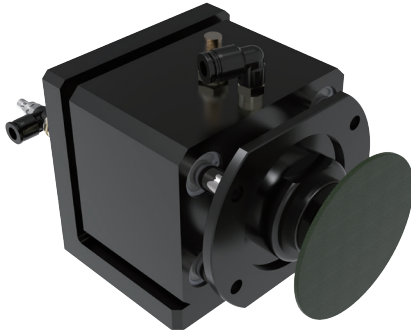

mindman



(Grinding wheel not included, must be purchased separately)

## Feature

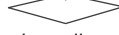
- Good for sanding surfaces. 
- Moderate compliant force and sanding power.
- Applicable material: Aluminum, copper, steel, plastic, composite materials, wood

## Specification

Model	TLG30S
Collet size (inch)	4" (16mm) / Grinding wheel
Compliant stroke (mm)	10 (One-sided)
Compliant force (N)	26~66
Rated operate pressure (MPa)	Compliant: 0.2~0.5 Spindle: 0.6
Air consumption (LPM)	280
Recomm. lubricating oil (*1)	Turbine oil ISO-VG32
Oscillating frequency (RPM)	2800
Ambient temperature (°C)	+5~+35
Ambient humidity (%)	< 95
Weight (kg)	2.6

## Order example

TLG30 S

MODEL SANDER

\*1. Only for the pneumatic spindle. Adjust oil quantity as needed.

\*2. Do not disassemble this product yourself. For repairs or replacement of consumables, please contact our sales.

\*3. The sander is suitable only for material removal and not for surface grinding.

No.	Part	Qty	Note
1	Silencer	1	
2	Clamping seat	1	
3	Pneumatic grinder	1	
4	Compliant elements	2	6 mm fitting
5	Speed control connector	2	
6	Base plate	1	
7	Elbow connector	1	6 mm fitting
8	Grinding wheel	0	Purchased separately

