

# TRG20 series

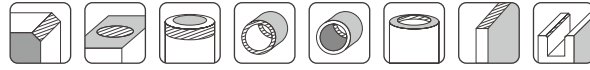

## PNEUMATIC SPINDLE – RADIAL COMPLIANT TOOL

mindman



Manual



Model selection



Caution for safety  
(Read before installing)



(Milling bur not included, must be purchased separately)

### Feature

- Good for small burrs on complex curved edges.
- Ultra-high speed and minimal compliance force, utilizing pneumatic control to handle ultra-small gaps. Supports highly sensitive radial compliance, ensuring precise surface finishing. Ideal for deburring small components.
- Applicable material: Aluminum, copper, steel

### Specification

Model	TRG20
Compliant stroke (°)	3.5 (Radial)
Compliant force (N)	2~10
Rated operate pressure (MPa)	Compliant: 0.2~0.5 Spindle: 0.6
Air consumption (LPM)	Compliant: Neglectable Spindle: 150
Recomm. lubricating oil (*1)	Turbine oil ISO-VG32
Oscillating speed (RPM)	65000
Collet size (mm)	3 (Milling bur)
Weight (kg)	1.3

\*1. Only for the pneumatic spindle. Adjust oil quantity as needed.

\*2. Do not disassemble this product yourself. For repairs or replacement of consumables, please contact our sales.

### Order example

TRG20

MODEL

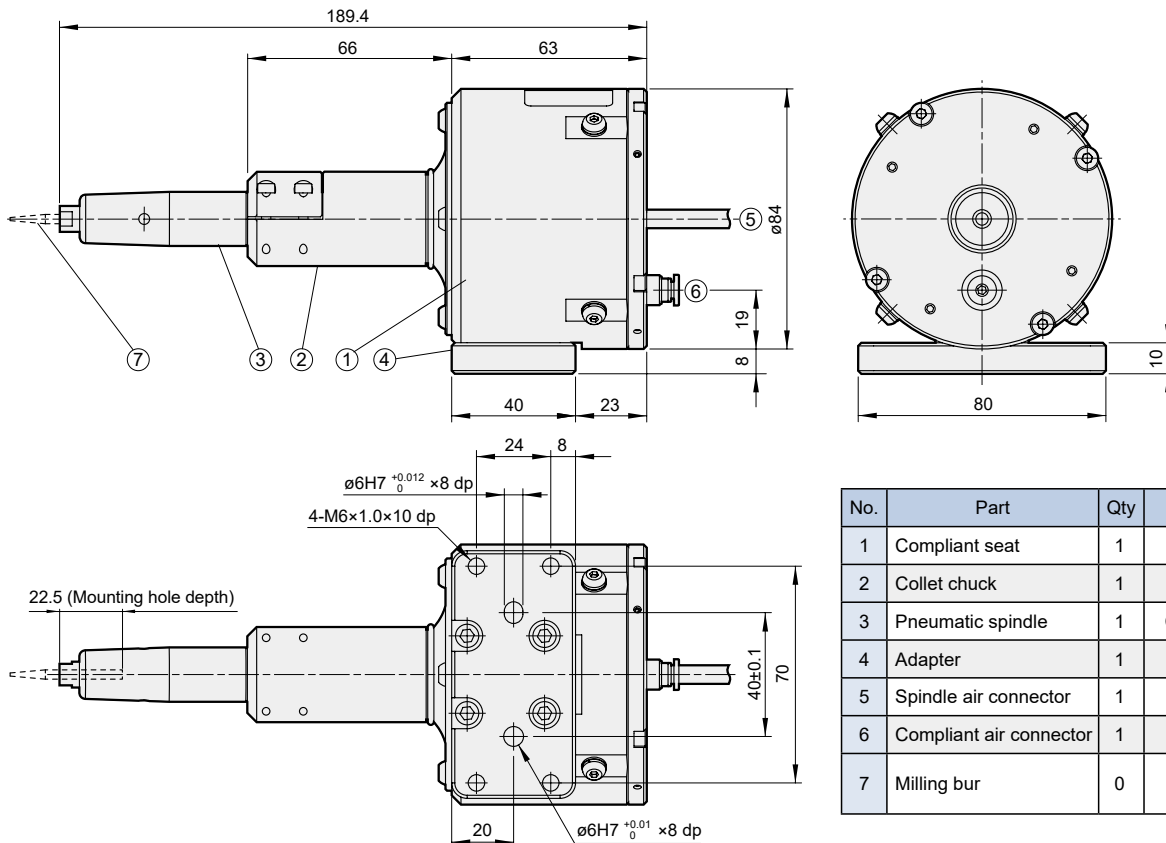

No.	Part	Qty	Note
1	Compliant seat	1	–
2	Collet chuck	1	–
3	Pneumatic spindle	1	Consumables
4	Adapter	1	–
5	Spindle air connector	1	6 mm tube
6	Compliant air connector	1	4 mm fitting
7	Milling bur	0	Purchased separately