

External Vacuum Controller realizing Stable and High-speed Response External Vacuum Controller VNP Series

394

VNP

- *Suitable for semiconductor industry such as IC chip loader or IC handler.*

- *Suitable for the application requiring a limited space.*

Compact and lightweight External Vacuum Controller. The body height is lowered in particular.

- Stand-alone type



- Manifold type

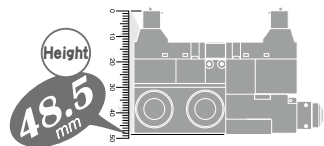

Characteristics

- *Wide variety of combinations enables to meet various applications. Complex Vacuum Generator VN Series is also available. (P.282).*

- *High-speed response time. (ON / OFF = 5msec or less)*

Direct operated solenoid valve is used for the main valve.

Conventional Vacuum Controllers

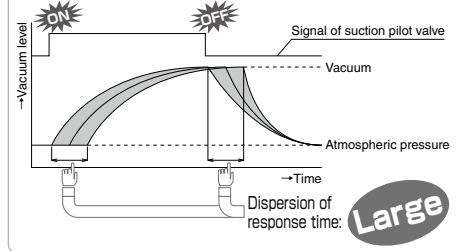

External Vacuum Controller VNP

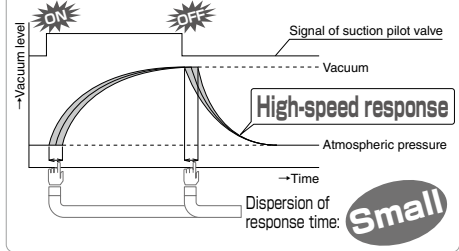

- *Four types of analog output type sensor are prepared.*

Analog output type vacuum pressure sensor for negative pressure, Separate LED indicator + Analog output type vacuum pressure sensor for negative pressure, Analog output type sensor for compound pressure, Separate LED indicator + Analog output type sensor for compound pressure

Analog output type sensor		Separate LED indicator + Analog output type sensor	
Negative pressure	Compound pressure	Negative pressure	Compound pressure

- *External vacuum filter (option) is prepared.*

Inconvenience from filter replacement due to the downsizing of this vacuum generator is resolved.

※ Vacuum Generator VN series is not equipped with vacuum filter. Please make sure to order PISCO vacuum filter (VFU or VFJ on page 758) separately for long-term use.

Model Designation of Stand-Alone Type (Example)

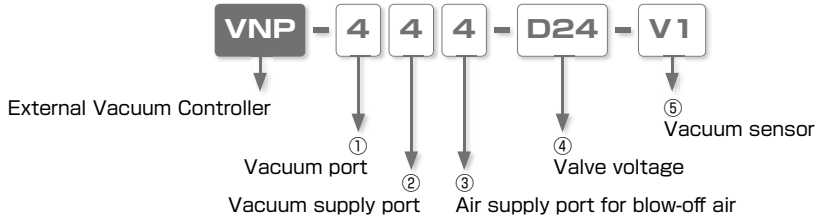

① Vacuum port (Applicable tube size)

Code	3	4	3L	4L
Tube dia.(mm)	ø3 (Straight push-in fitting)	ø4 (Straight push-in fitting)	ø3 (Elbow push-in fitting)	ø4 (Elbow push-in fitting)

② Vacuum supply port (Applicable tube size)

Code	3	4
Tube dia.(mm)	ø3 (Straight push-in fitting)	ø4 (Straight push-in fitting)

③ Air supply port for blow-off air (Applicable tube size)

Code	3	4
Tube dia.(mm)	ø3 (Straight push-in fitting)	ø4 (Straight push-in fitting)

④ Valve voltage

Code	D24
Voltage	24VDC

⑤ Vacuum sensor

Code	No code	
Sensor	Without vacuum sensor	
Code	V1	V2
Sensor	Analog output type vacuum sensor for negative pressure	Separate LED indicator + Analog output type vacuum sensor for negative pressure
Code	R1	R2
Sensor	Analog output type sensor for compound pressure	Separate LED indicator + Analog output type sensor for compound pressure

Model code of Unit Bracket (Option)

VNB

※ . Including 2 hexagonal socket head screw (M3×12).

Model code of Silencer Element (Maintenance Parts)

VNO12B32

External Vacuum Controller Series

External Vacuum Controller VNP Series

VACUUM GENERATOR
EXTERNAL VACUUM CONTROLLER

Model Designation of Manifold Type (Example)

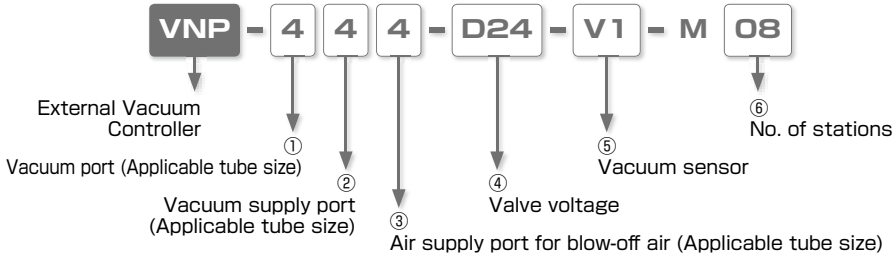

① Vacuum port (Applicable tube size)

Code	3	4	3L	4L	K
Tube dia.(mm)	ø3 (Straight push-in fitting)	ø4 (Straight push-in fitting)	ø8 (Elbow push-in fitting)	ø10 (Elbow push-in fitting)	When different vacuum ports are mixed on a manifold (Fill in the details on Specification Order Form)

② Vacuum supply port (Applicable tube size)

Code			Tube dia.(mm) & Type
Both sides	R-side only	L-side only	
4	4R	4H	ø4 (Straight push-in fitting)
6	6R	6H	ø6 (Straight push-in fitting)
8	8R	8H	ø8 (Straight push-in fitting)
4L	4LR	4LH	ø4 (Elbow push-in fitting)
6L	6LR	6LH	ø6 (Elbow push-in fitting)
8L	8LR	8LH	ø8 (Elbow push-in fitting)

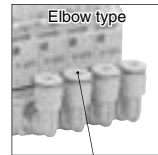
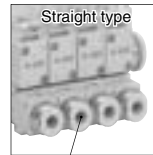

Vacuum port

Vacuum port

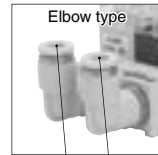
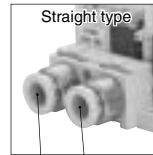

Air supply port for blow-off air
Vacuum supply port

Air supply port for blow-off air
Vacuum supply port

③ Air supply port for blow-off air (Applicable tube size)

Code			Tube dia.(mm) & Type
Both sides	R-side only	L-side only	
4	4R	4H	ø4 (Straight push-in fitting)
6	6R	6H	ø6 (Straight push-in fitting)
8	8R	8H	ø8 (Straight push-in fitting)
4L	4LR	4LH	ø4 (Elbow push-in fitting)
6L	6LR	6LH	ø6 (Elbow push-in fitting)
8L	8LR	8LH	ø8 (Elbow push-in fitting)

④ Valve voltage

Code	D24
Voltage	24VDC

⑤ Vacuum sensor

Code	No code	
Sensor	Without vacuum sensor	
Code	V1	V2
Sensor	Analog output type vacuum sensor for negative pressure	Separate LED indicator + Analog output type vacuum sensor for negative pressure
Code	R1	R2
Sensor	Analog output type compound pressure sensor	Separate LED indicator + Analog output type compound pressure sensor
Code	K	
Sensor	When different sensors are mixed on a manifold (Fill in the details on Specification Order Form)	

⑥ No. of stations

Code	02	03	04	05	06	07	08	09	10
No. of stations	2	3	4	5	6	7	8	9	10

■ Specification Order Form (example)

External vacuum controller type		Vacuum port ①	Vacuum supply port (PV) ②	Air supply port for blow-off air (PS) ③	Valve voltage ④	Vacuum sensor ⑤	No. of stations ⑥
VNP		K	8	8	D24	K	M04
L ↑ St. no. ↓ R	St. 1	3L					
	St. 2	3L					
	St. 3	4				V1	
	St. 4	4				V1	
	St. 5						
	St. 6						
	St. 7						
	St. 8						
	St. 9						
	St. 10						

※ Station no. is arranged St.1, St.2 ... St.10 from L side.

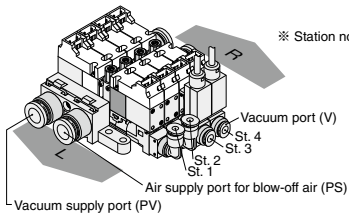

Vacuum Controller VNP Series Specification Order Form

To: NIHON PISCO CO., Ltd. _____

Name: _____

Order No.: _____

Date: _____

Request EX-W PISCO Date: _____ Quantity: _____

External vacuum controller type		Vacuum port ①	Vacuum supply port (PV) ②	Air supply port for blow-off air (PS) ③	Valve voltage ④	Vacuum sensor ⑤	No. of stations ⑥
VNP		—			— D24		—
L ↑ St. 1 St. 2 St. 3 St. 4 St. 5 St. 6 St. 7 ↓ St. 8 St. 9 R	St. 1	—			—		
	St. 2	—			—		
	St. 3	—			—		
	St. 4	—			—		
	St. 5	—			—		
	St. 6	—			—		
	St. 7	—			—		
	St. 8	—			—		
	St. 9	—			—		
	St. 10	—			—		

※ 1. Refer to the previous page to fill in the form.

※ 2. Copy this page and use.

※ 3. Use this specification order form when ordering different specifications of mounting units.

■ Construction of Stand-alone type, With vacuum sensor

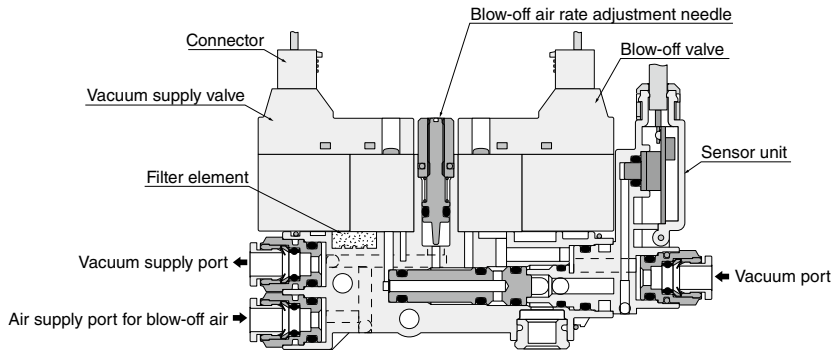

■ Construction of Manifold type, Without vacuum sensor

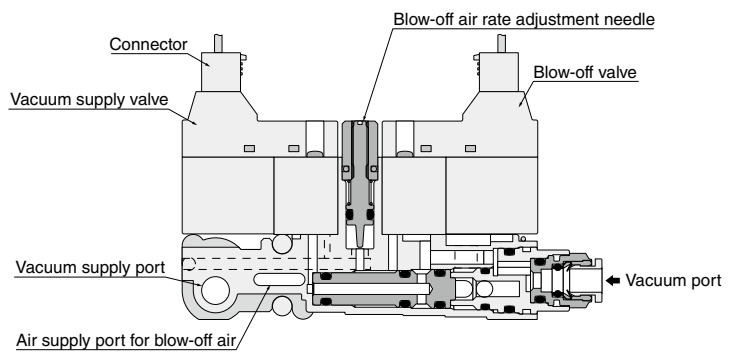

Mechanism of VNP

① When suction valve is off (At vacuum generation suspended)

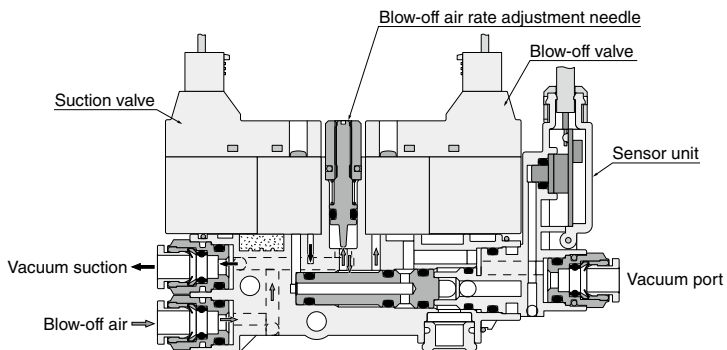

② When suction valve is on (At vacuum suction)

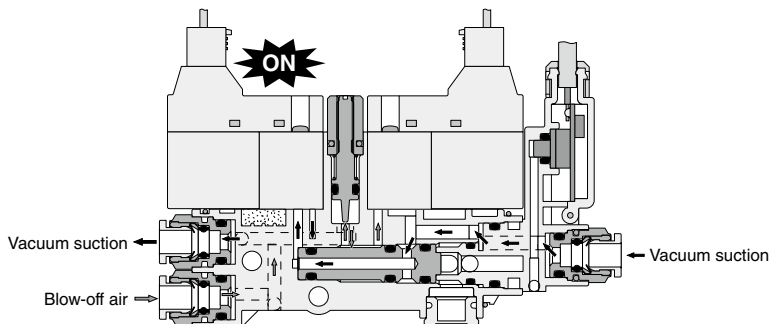

③ When blow-off valve is on (At blow-off air supply)

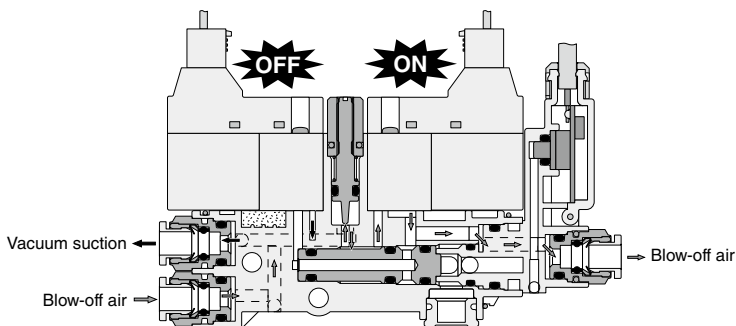

Specification

Fluid medium	Air
Operating pressure range	0 ~ 0.5MPa
Operating temp. range	5 ~ 50°C (No freezing)
Operating humidity range	35 ~ 85%RH (No dew condensation)
Protective structure	IEC standard IP40 equiv.
Vibration and impact resistance	Less than 50m/s ² / Less than 150m/s ²
Operating vacuum range	0 ~ -100kPa

Solenoid Valve

Item	Suction valve	Blow-off valve
Operating system	Direct operation	
Valve construction	Elastic seal, Poppet valve	
Rated voltage	24VDC	
Allowable voltage range	±10%	
Surge protection circuit	Surge absorber	
Power consumption	Startup: 2.2W	Retention: 0.6W (Power saving circuit)
Operation indicator LED	Green RED	
Operating pressure range	-100 ~ 0kPa	0 ~ 0.5MPa
Valve type	Normally closed	
Response time (※)	Vacuum suction (OFF → ON) / Vacuum stop (ON → OFF): 5 msec or less for each	
Wiring method	Connector (Cable length: 500mm)	
	Red lead wire: +24VDC, Black lead wire: -0V	

(※) Response time is the time length until pressure change at vacuum port is detected under rated supply pressure and rated voltage. Vacuum arrival time and blow-off time at the piping end (work-piece) vary according to ejector characteristics, volume (tube length), blow-off air rate and others.

Blow-Off Function

Blow-off air rate	0 ~ 20ℓ/min[ANR] (When supply pressure is at 0.5MPa)
-------------------	--

※. Air rate is adjustable with the blow-off air rate adjustment needle.

Vacuum Flow Rate

Vacuum Flow Rate	8ℓ/min[ANR] (When supply pressure is at -80kPa)
------------------	---

Vacuum Sensor

Item	Negative pressure (-V1)	Compound pressure (-R1)	
Rated voltage	10.8 ~ 30VDC (Ripple included)		
Current consumption	Less than 20mA (24VDC at no-load)		
Pressure detection	Proliferated semiconductor pressure sensor, gauge pressure		
Operating pressure range	-100 ~ 0kPa	-100 ~ 300kPa	
Proof pressure	200kPa	600kPa	
Storage temperature rang	-20 ~ 70°C (Atmospheric pressure / Humidity: 65% RH or less)		
Operating temp. range	-10 ~ 60°C (No freezing)		
Operating humidity range	35 ~ 85%RH (No dew condensation)		
Protective structure	IEC standard IP40 equiv.		
Analog output	Output voltage	1 ~ 5V	
	Zero-point voltage	1±0.1V (=Atmospheric pressure)	1±0.1V (At -100kPa)
	Max. pressure voltage	5±0.1V (At -100kPa)	5±0.1V (At 300kPa)
	Linearity	±0.5% F.S. or less (at Ta=25°C)	
	Temperature characteristics	±2% F.S. or less (0 ~ 50°C, Ta=25°C)	
	Output current	Output current: 1mA max. (load resistance 50kΩ max.)	

Circuit diagram

Solenoid valve

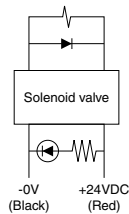

Vacuum sensor

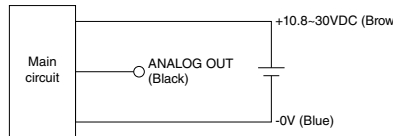

Characteristics

Flow characteristics Chart

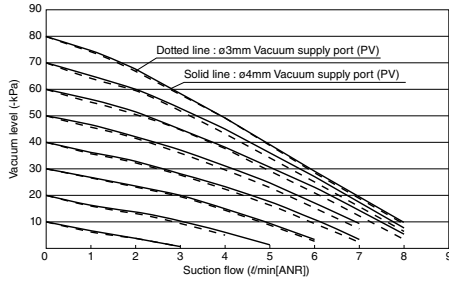

Flow characteristics of blow-off air

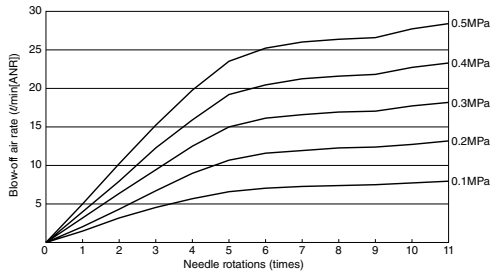

How to insert and disconnect

1. How to insert and disconnect tubes

① Tube insertion

Insert a tube into Push-In Fitting of External Vacuum Controller VNP up to the tube end. Lock-claws bites the tube to fix it automatically and the elastic sleeve seals around the tube.

Refer to "2. Instructions for Tube Insertion" under "Common Safety Instructions for Fittings" .

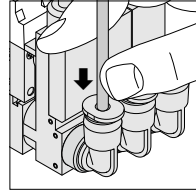

② Tube disconnection

The tube is disconnected by pushing release-ring to release Lock-claws.

Make sure to stop air supply before the tube disconnection.

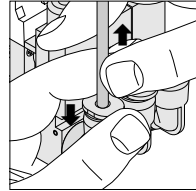

2. How to fix Stand-alone/Manifold type

In order to fix the vacuum generator, use the fixing holes on the body to tighten with M3 thread with tightening torque 0.3-0.35Nm. Tightening by the torque out of the recommended range may result in falling of the product or damaging the products. .

Refer to the outer dimensional drawings of the mounting hole pitch.

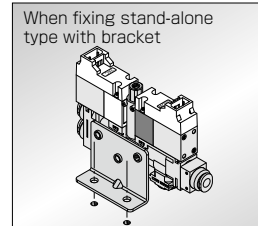
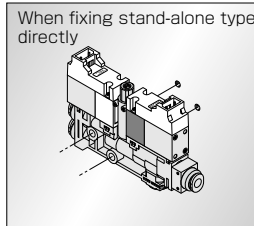
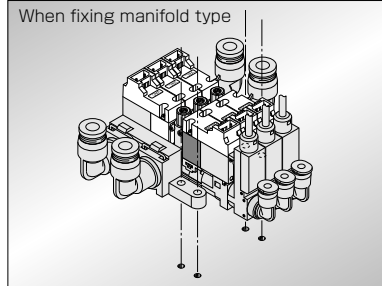

Weight List

Model code	Unit combinations	Weight (g)
VNP-□□□-D24-□	Stand-alone with vacuum sensor	56
VNP-□□□-D24	Stand-alone without vacuum sensor	52.5
VNP-M	Manifold-base alone	171

■ For manifold type, weight of mounting unit increases by 46.5g/ mounting unit with a sensor, and 43g/mounting unit without a sensor.

Example) 4 stations with vacuum sensor

$171 + (4 \times 46.5) = 357\text{g}$ → Manifold weight (171g) + weight of 4 mounting units with vacuum sensor (186g)

■ Applicable Tube and Related Products

Polyurethane Tube (1. Piping products catalog P.596)

■ Polyurethane Tube is for the general pneumatic piping and suitable for a compact piping.

Nylon Tube (1. Piping products catalog P.608)

■ Nylon Tube is for the general pneumatic piping and suitable for a high-pressure fluid up to 1.5MPa (NB tube: 1.0MPa).

Vacuum Tube (1. Piping products catalog P.612)

■ Vacuum Tube is a ultra-soft tube and suitable for piping of vacuum generators or actuators.

Vacuum Pads

- Vacuum Pad Standard Series . . . P.428
- Vacuum Pad Sponge Series . . . P.468
- Vacuum Pad Bellows Series . . . P.488
- Vacuum Pad Multi-Bellows Series P.508
- Vacuum Pad Oval Series P.526
- Vacuum Pad Soft Series P.550
- Vacuum Pad Soft Bellows Series P.578
- Vacuum Pad Skidproof Series . . P.604
- Vacuum Pad Ultrathin Series . . P.624
- Vacuum Pad Mark-free Series . . P.642
- Vacuum Pad Long Stroke Series · P.658

■ Standard Size List

Without vacuum sensor

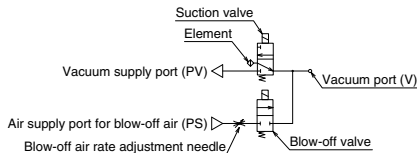

Type	Page	Vacuum port	Vacuum supply port		Air supply port for blow-off air
			3mm	4mm	
VNP	407	3mm	●	●	3mm
		4mm	●	●	4mm

With vacuum sensor

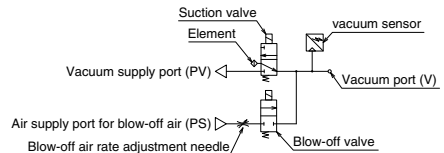

Type	Page	Vacuum port	Vacuum supply port		Air supply port for blow-off air
			3mm	4mm	
VNP	407	3mm	●	●	3mm
		4mm	●	●	4mm

External Vacuum Controller Series

External Vacuum Controller VNP Series

VACUUM GENERATOR
EXTERNAL VACUUM CONTROLLER

VNP Stand-alone type, Without vacuum sensor



Model code : VNP-□□□-D24

Circuit diagram

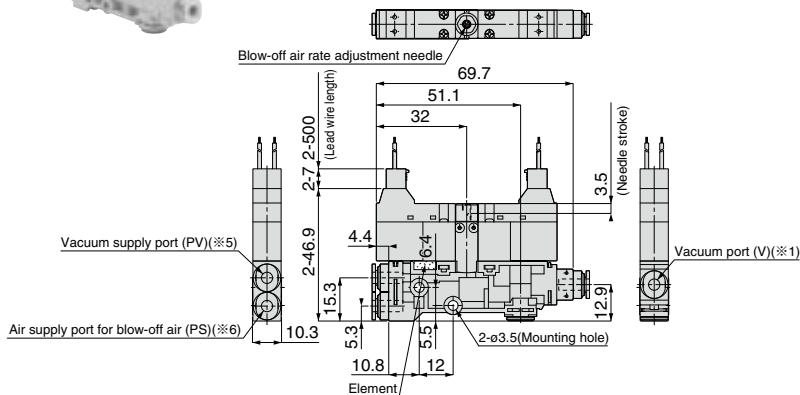
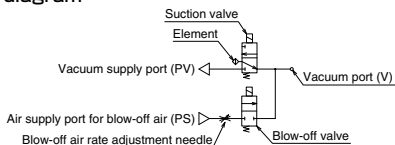
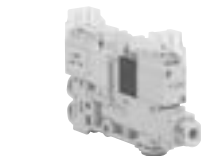

- ※ 1. Refer to table 1 on page 408 for the dimension of Vacuum port (V).
- ※ 2. Refer to table 2 on page 408 for the dimension of Vacuum supply port.(PV).
- ※ 3. Refer to table 2 on page 408 for the dimension of Vacuum supply port for blow-off air (PS).

407

VNP Stand-alone type with vacuum sensor



Model code : VNP-□□□-D24-□ 1

Circuit diagram

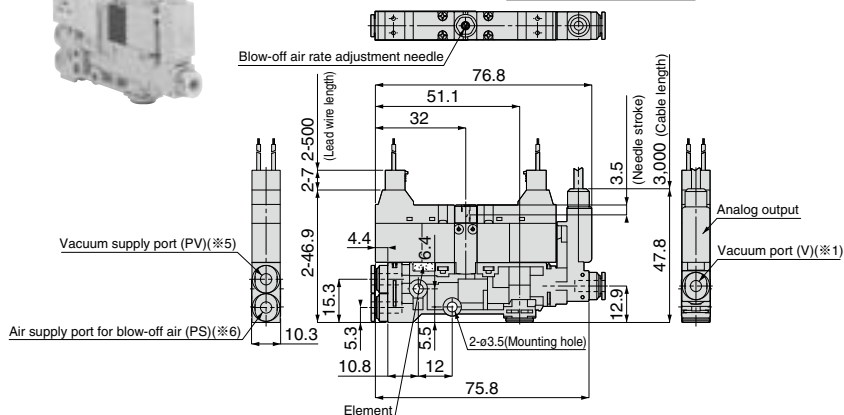
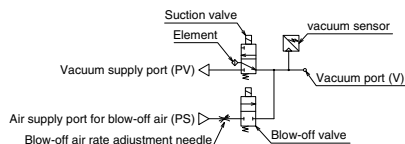
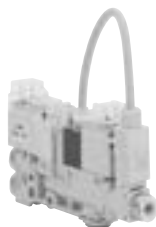

- ※ 1. Refer to table 1 on page 408 for the dimension of Vacuum port (V).
- ※ 2. Refer to table 2 on page 408 for the dimension of Vacuum supply port.(PV).
- ※ 3. Refer to table 2 on page 408 for the dimension of Vacuum supply port for blow-off air (PS).



Characteristic chart page

■ Fitting Dimension of Stand-Alone type

4(ø4 Straight type)	3(ø3 Straight type)	4L(ø4 Elbow type)	3L(ø3 Elbow type)

Table 1 : Push-In Fitting type of Vacuum port

4(ø4 Straight type)	3(ø3 Straight type)

Table 2 : Push-In Fitting type of Air supply port

VNB Bracket for Stand-Alone type (Option)

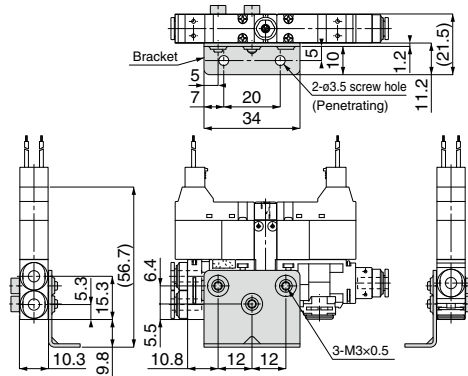

External Vacuum Controller Series

External Vacuum Controller VNP Series

VACUUM GENERATOR
EXTERNAL VACUUM CONTROLLER

VNP Manifold type, Without vacuum sensor

Model code : VNP-□□□-D24-M□

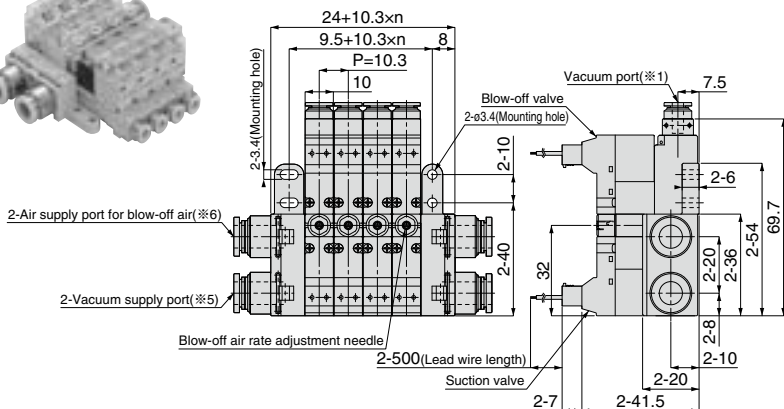
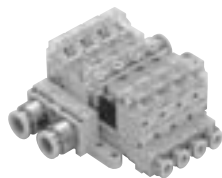

- ※ 1. Refer to table 1 on page 410 for the dimension of Vacuum port.
- ※ 2. Refer to table 2 on page 410 for the dimension of Vacuum supply port.
- ※ 3. Refer to table 2 on page 410 for the dimension of Vacuum supply port for blow-off air.

409

VNP Manifold type, With vacuum sensor

Model code : VNP-□□□-D24-□ 1-M□

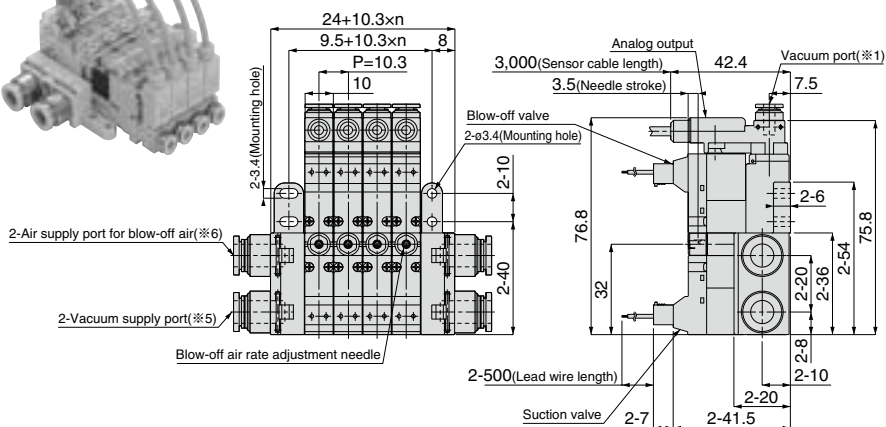
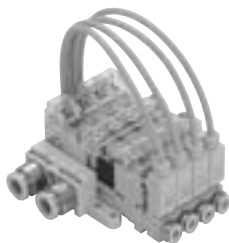

- ※ 1. Refer to table 1 on page 410 for the dimension of Vacuum port.
- ※ 2. Refer to table 2 on page 410 for the dimension of Vacuum supply port.
- ※ 3. Refer to table 2 on page 410 for the dimension of Vacuum supply port for blow-off air.

■ Fitting Dimension of Manifold type

			
4(ø4 Straight type)	3(ø3 Straight type)	4L(ø4 Elbow type)	3L(ø3 Elbow type)

Table 1 : Push-In Fitting of Vacuum port

			
8(ø8 Straight type)	6(ø6 Straight type)	4(ø4 Straight type)	Plug(For one-side supply)
			
8(ø8 Elbow type)	6(ø6 Elbow type)	4(ø4 Elbow type)	

Table 2 : Push-In Fitting of Air supply port

Before using PISCO products, be sure to read "Safety Instructions" and "Safety Instruction Manual" on page 35-39 and "Common Safety Instructions for Vacuum Series" on page 47-49.

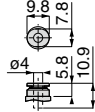
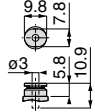
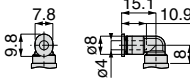
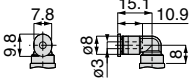
Warning

【Products Handling】

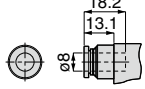
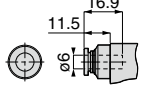
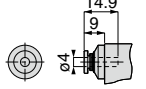
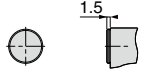
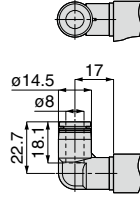
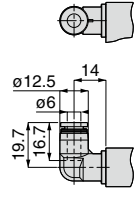
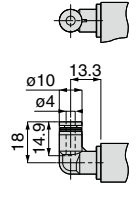
1. Do not step onto or place objects on the devices. These may cause falling accident, fall of devices, injuries from falling and malfunctions from device breakage.
2. Do not wash or paint the devices with solvent or water. Solvent use may cause breakage of resin parts and malfunction by port clogs.

【Products maintenance】

1. Carry out maintenance and checks of equipment only after turning power off, shutting air off and making sure that the residual pressure in the piping has dropped to zero.
2. When installing wiring and piping, be sure to switch off the power and make sure there is no wrong wiring and wrong piping before applying power and air.
3. Tighten screws with recommended tightening torque. The recommended tightening torque for fixing device is specified on "How to fix Stand alone / Manifold type" on page 405. The recommended tightening torque is written on " How to replace Filter Elements" on page 413. Improper tightening may cause air leakage, dropout or breakage of the products.

【Products application】

1. For the operation of the solenoid valve, make sure that the leakage current is less than 1mA. Leakage current larger than that may cause malfunction.
2. Avoid applying excessive vibration or shocks to the devices. (Check the specification on page 293.) It may damage devices and lead to malfunction of solenoid valve.
3. The coil in a pilot solenoid valve generates heat under the following ① to ③ conditions. The heat may cause dropping life cycle, malfunctions, getting burnt or damaging peripheral machines.
Contact us when the power is applied to the vacuum generator under the following conditions:
 - ① The power is continuously ON for over 2 hours.
 - ② High-cycle operation.
 - ③ Even when intermittent running of the generator is carried out, the total operation time per day is longer than non-operation time.
4. When the electricity is applied to valves continuously for a long time, the coils generate heat. It may cause dropping life cycle, malfunctions, getting burnt or damaging peripheral machines due to the heat.
5. Current limit circuit is adopted for the solenoid valve. It features the current drop when the coil is energized and retains current. Therefore, the use under the vibration or shock greater than the specification must be avoided. It may cause valve malfunction.

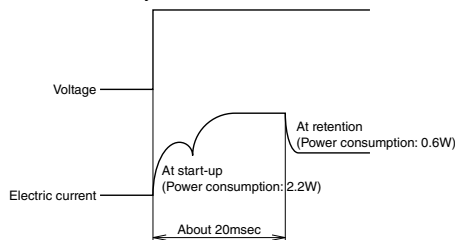

Electric current and voltage waveform at valve excitation

Caution

[Products Handling]

1. Do not give an excessive tensile strength and bending on a lead wire. Otherwise, breaking wire or damage on connector may be caused.
2. Compressed air contains many kinds of drains such as water, oxidized oil, tar and other foreign substances. Dehumidify the compressed air by using an after-cooler or a dryer and improve the air quality, since those drains seriously impair the performance of the vacuum generator.
3. Do not use lubricators.
4. Foreign substances such as rusts or dust in the pipes may cause malfunction. Place a filter finer than 5µm ahead of the air supply port. It is recommended to carry out pipe flushing before operation and on a proper regular basis.
5. Avoid using the vacuum generator under the condition of corrosive and / or inflammable gas. Also do not use these gasses as a fluid medium.
6. The product is not drip/dust proof. Do not use the vacuum generator in location where it may be exposed to water, oil drop or dust.
7. The lead wire of solenoid valve is polarized. Therefore, wrong polarity does not activate the solenoid valve.

[Products maintenance]

1. When replacing cartridge fittings for air supply (PS, PV) or vacuum (V) port, be sure to remove foreign substances from the seal and fix the fastening pin firmly in place.
2. The performance of silencer may deteriorate due to when much dust is stuck on the elements of External Vacuum Controller. Periodical cleaning and replacing of the elements are recommended.

[Products application]

1. In selecting the piping to the vacuum (V) port, secure piping bore and length for enough effective sectional area. Insufficient effective sectional area may cause performance drop in characteristics such as suction flow and vacuum release airflow.
2. In selecting the piping to the supply (PS,PV) port, select piping bore and length to secure enough effective sectional area. Insufficient effective sectional area may cause performance drop due to short supply of compressed air and vacuum flow.
3. This product is not equipped with a vacuum filter. Make sure to select and use PISCO vacuum filter. If the filter is not used, dust or other particles are accumulated inside the product and cause vacuum performance drop and solenoid valve malfunction such as air leakage. (Recommended filter: VFU series and VFJ series)
4. As for manifold types, allowable station numbers for the simultaneous operation depends on the condition of the air supply (supply port size, piping length, regulator processing flow rate and etc.) and/or air consumption (vacuum characteristics) of ejector. If simultaneous operation of mounting units on a manifold is required, contact PISCO before the use.
5. Although the exhaust of the model with a manifold type is silencer vent by each individual unit, the exhaust air of operating unit or blow-off air flows into the vacuum port of non-operating unit. If such exhaust air causes the problem, please contact PISCO.

⚠ Safety Rules for Use

■ How to replace Filter Elements

- Use a Phillips screwdriver and remove a suction valve in order to replace a filter element (Model code: VN012B32). Make sure to insert the pin in the proper position after the replacement. Pay attention not to lose seal rubbers of Suction valve before tightening the fixing threads with the tightening torque 0.15-0.2Nm.

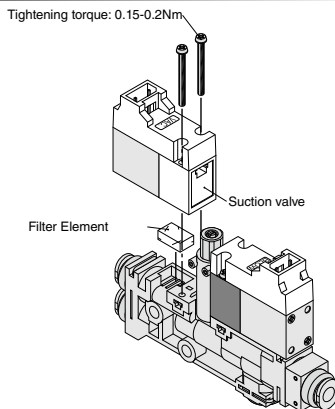

■ How to replace Cartridge Fittings in Vacuum Port

■ Stand-Alone Type

Pull out the spring pins (2 pieces) inserted from the side of vacuum port block with or without sensor unit with the jig like $\varnothing 1\text{mm}$ pin and replace the cartridge fitting.

- ※ When attaching a new cartridge fitting, make sure to remove dusts or fluffs stuck on O-ring. O-ring and inside of the body shall not be damaged, since it may cause a performance drop.

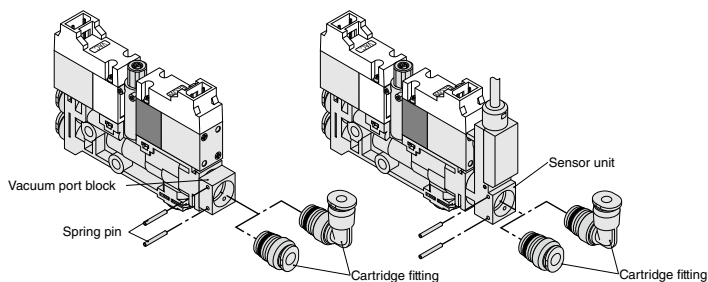

■ Manifold Type

Using a suitable Philips screwdriver to remove the vacuum blow-off valve. Pull out the fixing pin using a flat-blade screwdriver and remove the vacuum port block with or without sensor unit. Pull out the spring pins (2 pieces) inserted from the side of the vacuum port block with the jig like $\phi 1\text{mm}$ pin and replace the cartridge fittings. After checking the packing for the vacuum supply valve is not missing, securely tighten the two fixing screws with a tightening torque of 0.15-0.2N.m.

※ When attaching a new cartridge fitting, make sure to remove dusts or fluffs stuck on O-ring. O-ring and inside of the body shall not be damaged, since it may cause a performance drop.

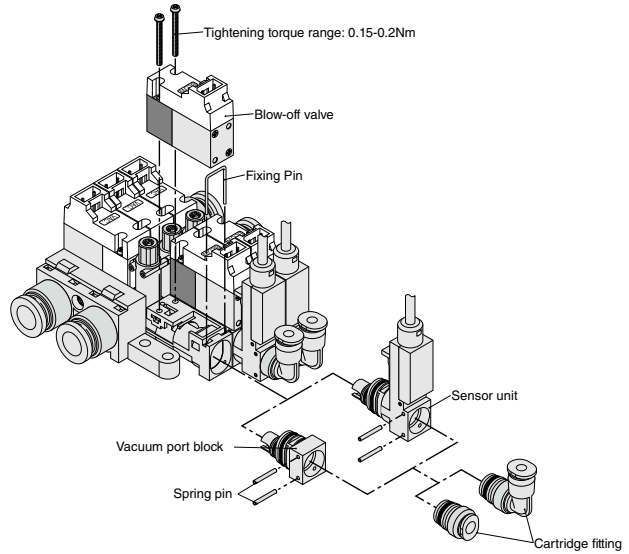

How to replace Cartridge Fittings of Supply Port

Stand-Alone Type

Using a suitable Philips screwdriver to remove suction valve. Pull out a fixing pin on suction air supply port and blow-off air supply port with a flathead screwdriver. After checking the packing for vacuum supply valve is not missing, securely tighten the two fixing screws with tightening torque of 0.15-0.2N·m.

※ When attaching a new cartridge fitting, make sure to remove dusts or fluffs stuck on O-ring. O-ring and inside of the body shall not be damaged, since it may cause a performance drop.

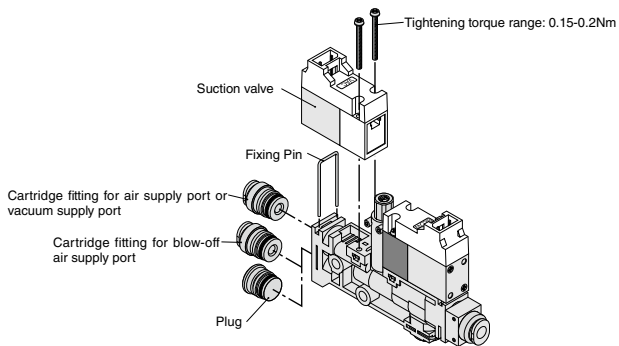

Manifold Type

Pull out the fixing pin with a flathead screwdriver and replace cartridge fittings.

※ When attaching a new cartridge fitting, make sure to remove dusts or fluffs stuck on O-ring. O-ring and inside of the body shall not be damaged, since it may cause a performance drop.

※ Be careful of the direction of fixing pin. If the fixing pin is inserted with a wrong direction, the pin may drop off due to vibration.

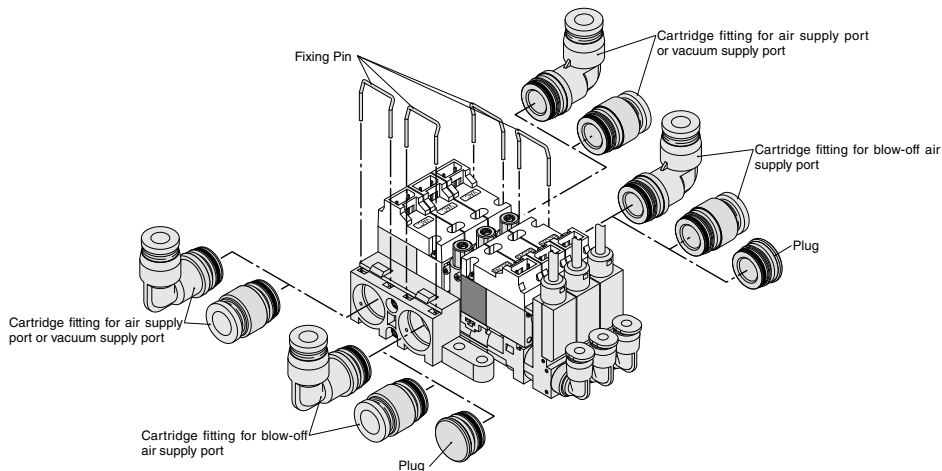



SAFETY Instructions

This safety instructions aim to prevent personal injury and damage to properties by requiring proper use of PISCO products.

Be certain to follow ISO 4414 and JIS B 8370

ISO 4414 : Pneumatic fluid power...Recommendations for the application of equipment to transmission and control systems.

JIS B 8370 : General rules and safety requirements for systems and their components.

This safety instructions is classified into "Danger", "Warning" and "Caution" depending on the degree of danger or damages caused by improper use of PISCO products.



Danger

Hazardous conditions. It can cause death or serious personal injury.



Warning

Hazardous conditions depending on usages. Improper use of PISCO products can cause death or serious personal injury.



Caution

Hazardous conditions depending on usages. Improper use of PISCO products can cause personal injury or damages to properties.



Warning

1. Selection of pneumatic products

- ① A user who is a pneumatic system designer or has sufficient experience and technical expertise should select PISCO products.
- ② Due to wide variety of operating conditions and applications for PISCO products, carry out the analysis and evaluation on PISCO products. The pneumatic system designer is solely responsible for assuring that the user's requirements are met and that the application presents no health or safety hazards. All designers are required to fully understand the specifications of PISCO products and constitute all systems based on the latest catalog or information, considering any malfunctions.

2. Handle the pneumatic equipment with enough knowledge and experience

- ① Improper use of compressed air is dangerous. Assembly, operation and maintenance of machines using pneumatic equipment should be conducted by a person with enough knowledge and experience.

3. Do not operate machine / equipment or remove pneumatic equipment until safety is confirmed.

- ① Make sure that preventive measures against falling work-pieces or sudden movements of machine are completed before inspection or maintenance of these machine.
- ② Make sure the above preventive measures are completed. A compressed air supply and the power supply to the machine must be off, and also the compressed air in the systems must be exhausted.
- ③ Restart the machines with care after ensuring to take all preventive measures against sudden movements.

Disclaimer

1. PISCO does not take any responsibility for any incidental or indirect loss, such as production line stop, interruption of business, loss of benefits, personal injury, etc., caused by any failure on use or application of PISCO products.
2. PISCO does not take any responsibility for any loss caused by natural disasters, fires not related to PISCO products, acts by third parties, and intentional or accidental damages of PISCO products due to incorrect usage.
3. PISCO does not take any responsibility for any loss caused by improper usage of PISCO products such as exceeding the specification limit or not following the usage the published instructions and catalog allow.
4. PISCO does not take any responsibility for any loss caused by remodeling of PISCO products, or by combinational use with non-PISCO products and other software systems.
5. The damages caused by the defect of Pisco products shall be covered but limited to the full amount of the PISCO products paid by the customer.



SAFETY INSTRUCTION MANUAL

PISCO products are designed and manufactured for use in general industrial machines. Be sure to read and follow the instructions below.

Danger

1. Do not use PISCO products for the following applications.
 - ① Equipment used for maintaining / handling human life and body.
 - ② Equipment used for moving / transporting human.
 - ③ Equipment specifically used for safety purposes.

Warning

1. Do not use PISCO products under the following conditions.
 - ① Beyond the specifications or conditions stated in the catalog, or the instructions.
 - ② Under the direct sunlight or outdoors.
 - ③ Excessive vibrations and impacts.
 - ④ Exposure / adhere to corrosive gas, inflammable gas, chemicals, seawater, water and vapor. *
 - * Some products can be used under the condition above(④), refer to the details of specification and condition of each product.
2. Do not disassemble or modify PISCO products, which affect the performance, function, and basic structure of the product.
3. Turn off the power supply, stop the air supply to PISCO products, and make sure there is no residual air pressure in the pipes before maintenance and inspection.
4. Do not touch the release-ring of push-in fitting when there is a working pressure. The lock may be released by the physical contact, and tube may fly out or slip out.
5. Frequent switchover of compressed air may generate heat, and there is a risk of causing burn injury.
6. Avoid any load on PISCO products, such as a tensile strength, twisting and bending. Otherwise, there is a risk of causing damage to the products.
7. As for applications where threads or tubes swing / rotate, use Rotary Joints, High Rotary Joints or Multi-Circuit Rotary Block only. The other PISCO products can be damaged in these applications.
8. Use only Die Temperature Control Fitting Series, Tube Fitting Stainless SUS316 Series, Tube Fitting Stainless SUS316 Compression Fitting Series or Tube Fitting Brass Series under the condition of over 60°C (140° F) water or thermal oil. Other PISCO products can be damaged by heat and hydrolysis under the condition above.
9. As for the condition required to dissipate static electricity or provide an antistatic performance, use EG series fitting and antistatic products only, and do not use other PISCO products. There is a risk that static electricity can cause system defects or failures.
10. Use only Fittings with a characteristic of spatter-proof such as Anti-spatter or Brass series in a place where flame and weld spatter is produced. There is a risk of causing fire by sparks.
11. Turn off the power supply to PISCO products, and make sure there is no residual air pressure in the pipes and equipment before maintenance. Follow the instructions below in order to ensure safety.
 - ① Make sure the safety of all systems related to PISCO products before maintenance.
 - ② Restart of operation after maintenance shall be proceeded with care after ensuring safety of the system by preventive measures against unexpected movements of machines and devices where pneumatic equipment is used.
 - ③ Keep enough space for maintenance when designing a circuit.
12. Take safety measures such as providing a protection cover if there is a risk of causing damages or fires on machine / facilities by a fluid leakage.

⚠ Caution

1. Remove dusts or drain before piping. They may get into the peripheral machine / facilities and cause malfunction.
2. When inserting an ultra-soft tube into push-in fitting, make sure to place an Insert Ring into the tube edge. There is a risk of causing the escape of tube and a fluid leakage without using an Insert Ring.
3. The product incorporating NBR as seal rubber material has a risk of malfunction caused by ozone crack. Ozone exists in high concentrations in static elimination air, clean-room, and near the high-voltage motors, etc. As a countermeasure, material change from NBR to HNBR or FKM is necessary. Consult with PISCO for more information.
4. Special option "Oil-free" products may cause a very small amount of a fluid leakage. When a fluid medium is liquid or the products are required to be used in harsh environments, contact us for further information.
5. In case of using non-PISCO brand tubes, make sure the tolerance of the outer tube diameter is within the limits of Table 1.

● Table 1. Tube O.D. Tolerance

mm size	Nylon tube	Polyurethane tube	inch size	Nylon tube	Polyurethane tube
ø1.8mm	—	± 0.05mm	ø1/8	± 0.1mm	± 0.15mm
ø3mm	—	± 0.15mm	ø5/32	± 0.1mm	± 0.15mm
ø4mm	± 0.1mm	± 0.15mm	ø3/16	± 0.1mm	± 0.15mm
ø6mm	± 0.1mm	± 0.15mm	ø1/4	± 0.1mm	± 0.15mm
ø8mm	± 0.1mm	± 0.15mm	ø5/16	± 0.1mm	± 0.15mm
ø10mm	± 0.1mm	± 0.15mm	ø3/8	± 0.1mm	± 0.15mm
ø12mm	± 0.1mm	± 0.15mm	ø1/2	± 0.1mm	± 0.15mm
ø16mm	± 0.1mm	± 0.15mm	ø5/8	± 0.1mm	± 0.15mm

6. Instructions for Tube Insertion

- ① Make sure that the cut end surface of the tube is at right angle without a scratch on the surface and deformations.
- ② When inserting a tube, the tube needs to be inserted fully into the push-in fitting until the tubing edge touches the tube end of the fitting as shown in the figure below. Otherwise, there is a risk of leakage.

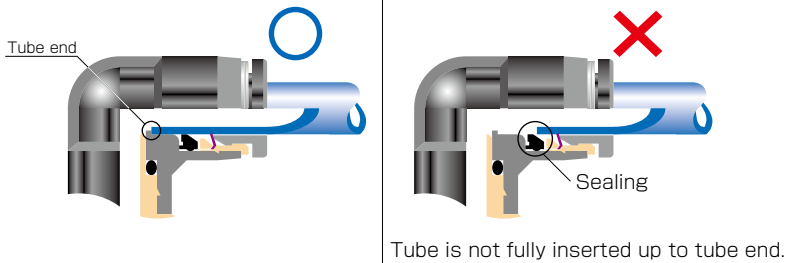

- ③ After inserting the tube, make sure it is inserted properly and not to be disconnected by pulling it moderately.
- ※ When inserting tubes, Lock-claws may be hardly visible in the hole, observed from the front face of the release-ring. But it does not mean the tube will surely escape. Major causes of the tube escape are the followings;
 - ① Shear drop of the lock-claws edge
 - ② The problem of tube diameter (usually small)
 Therefore, follow the above instructions from ① to ③, even lock-claws is hardly visible.

7. Instructions for Tube Disconnection

- ① Make sure there is no air pressure inside of the tube, before disconnecting it.
- ② Push the release-ring of the push-in fitting evenly and deeply enough to pull out the tube toward oneself. By insufficient pushing of the release-ring, the tube may not be pulled out or damaged by scratch, and tube shavings may remain inside of the fitting, which may cause the leakage later.

8. Instructions for Installing a fitting

- ① When installing a fitting, use proper tools to tighten a hexagonal-column or an inner hexagonal socket. When inserting a hex key into the inner hexagonal socket of the fitting, be careful so that the tool does not touch lock-claws. The deformation of lock-claws may result in a poor performance of systems or an escape of the tube.
- ② Refer to Table 2 which shows the recommended tightening torque. Do not exceed these limits to tighten a thread. Excessive tightening may break the thread part or deform the gasket and cause a fluid leakage. Tightening thread with tightening torque lower than these limits may cause a loosened thread or a fluid leakage.
- ③ Adjust the tube direction while tightening thread within these limits, since some PISCO products are not rotatable after the installation.

● Table 2: Recommended tightening torque / Sealock color / Gasket materials

Thread type	Thread size	Tightening torque	Sealock color	Gasket materials
Metric thread	M3 × 0.5	0.7N·m	—	SUS304 NBR
	M5 × 0.8	1.0 ~ 1.5N·m		
	M6 × 1	2 ~ 2.7N·m		
	M3 × 0.5	0.7N·m		POM
	M5 × 0.8	1 ~ 1.5N·m		
	M6 × 0.75	0.8 ~ 1N·m		
Taper pipe thread	M8 × 0.75	1 ~ 2N·m	White	—
	R1/8	4.5 ~ 6.5N·m		
	R1/4	7 ~ 9N·m		
	R3/8	12.5 ~ 14.5N·m		
Unified thread	R1/2	20 ~ 22N·m	—	SUS304, NBR
	No.10-32UNF	1.0 ~ 1.5N·m		
National pipe thread taper	1/16-27NPT	4.5 ~ 6.5N·m	White	—
	1/8-27NPT	4.5 ~ 6.5N·m		
	1/4-18NPT	7 ~ 9N·m		
	3/8-18NPT	12.5 ~ 14.5N·m		
	1/2-14NPT	20 ~ 22N·m		

※ These values may differ for some products. Refer to each specification as well.

9. Instructions for removing a fitting

- ① When removing a fitting, use proper tools to loosen a hexagonal-column or an inner hex bolt.
- ② Remove the sealant stuck on the mating equipment. The remained sealant may get into the peripheral equipment and cause malfunctions.

10. Arrange piping avoiding any load on fittings and tubes such as twist, tensile, moment load, shaking and physical impact. These may cause damages to fittings, tube deformations, bursting and the escape of tubes.



Common Safety Instructions for Vacuum Series

Before selecting or using PISCO products, read the following instructions. Read the detailed instructions for individual series.

Warning

1. If there is a risk of dropping work-pieces during vacuum suction, take a safety measure against the falling of them.
2. Avoid supplying more than 0.1MPa pressure constantly in a vacuum circuit. Since vacuum generators are not explosive-proof, there is a risk of damaging the products.
3. Pay attention to drop of vacuum pressure caused by problems of the supplied air or the power supply. Decrease of suction force may lead to a danger of falling work-piece so that safety measure against the falling of them is necessary.
4. When more than 2 vacuum pads are plumbed on a single ejector and one of them has a suction problem such as vacuum leak, there is a risk of releasing work-pieces from the other pad due to the drop of the vacuum pressure.
5. Do not use in the way by which exhaust port is blocked or exhaust resistance is increased. Otherwise, there is a risk of no vacuum generation or a drop of the vacuum pressure.
6. Do not use the product in the circumstance of corrosive gas, inflammable gas, explosive gas, chemicals, seawater and vapor or do not expose the product to those. Never allow the product to suck those things.
7. Provide a protective cover on the products when it is exposed to sunlight.
8. Carry out clogging check for silencer element in an ejector and a vacuum filter periodically. Clogged element will be a cause to impair the performance or a cause of troubles.
9. Before replacing the element, thoroughly read and understand the method of filter replacement in the catalog.
10. Make sure the correct port of the vacuum generator by this catalog or marking on the products when plumbing. Wrong plumbing can be a risk to damage the product.
11. Supply clean air without sludge or dusts to an ejector. Do not lubricate by a lubricator. There is a risk of malfunction or performance impairing by impurities and oil contained in the compressed air.
12. Do not apply extreme tension, twist or bending forces on a lead wire. Otherwise, it may cause a wire breaking.
13. Locknut needs to be tightened firmly by hand. Do not use any tool to tighten. In case of using tools to tighten the locknut, it may damage the locknut or the product. Inadequate tightening may loosen the locknut and the initial setting can be changed.
14. Do not force the product to rotate or swing even its resin body is rotatable. It may cause damage to the product and a fluid leakage.
15. Do not supply an air pressure or a dry air to the products over the necessary amount. There is a risk of deteriorating rubber materials and malfunction due to oil.
16. Keep the product away from water, oil drops or dusts. These may cause malfunction. Take a proper measure to protect the product before the operation.

17. Do not use the product in the environment of inflammable or explosive gas / fluid. It can cause a fire or an explosion hazard.
18. Do not use the product in the circumstance of corrosive gas, inflammable gas, explosive gas, chemicals, seawater and vapor or do not expose the product to those. Otherwise, it may be a cause of malfunction.
19. Do not clean or paint the products by water or a solvent.

⚠ Caution

1. Operating pressure range in the catalog is the values during ejector operation. Secure the described value of the supplied air, taking a drop of the pressure into consideration. Insufficient pressure, which does not satisfy the spec, may cause abnormal noise, unstable performance and may negatively affect sensors, bringing troubles at last.
2. Effective cross-section area of the air supply side needs to be three times as large as effective cross-section area of the nozzle bore. When arranging piping or selecting PISCO products, secure required effective cross-section area. Insufficient supply pressure may be a cause to impair performance.
3. A Shorter distance of plumbing with a wider bore is preferable at vacuum system side. A long plumbing with a small bore may result in slow response time at the time of releasing work-piece as well as in failure to secure adequate suction flow rate.
4. Plumb a vacuum switch and an ejector with vacuum switch at the end of vacuum system as much as possible. A long distance between a vacuum switch and a vacuum system end may increase plumbing resistance which may lead to a high vacuum level at the sensor even when no suctioning and a malfunction of vacuum switch. Make sure to evaluate the products in an actual system.
5. Refer to "4. Instructions for Installing a fitting" and "5. Instructions for Removing a fitting" under "Common Safety Instructions for Fittings" , when installing or removing Fittings.
6. Refer to "Common Safety Instructions for Pressure Sensors" and "Detailed Safety Instructions" for the handling of digital vacuum switch sensor.
7. Refer to "Common Safety Instructions for Mechanical Vacuum Sensor" for the handling of mechanical vacuum switch.
8. The material of plastic filter cover for VG, VK, VJ, VZ and VX series is PCTG. Avoid the adherence of Chemicals below to the products, and do not use them under those chemical environments.

● Table Chemical Name

Chemical Name
Thinner
Carbon tetrachloride
Chloroform
Acetate
Aniline
Cyclohexane
Trichloroethylene
Sulfuric acid
Lactic acid
Water soluble cutting oil (alkaline)

* There are more chemicals which should be avoided. Contact us for the use under chemical circumstance.

VACUUM GENERATOR
EXTERNAL VACUUM CONTROLLER
VACUUM PAD
VACUUM ACCESSORIES
48
VH-VS
VU
VUM
VY
VB
VM-VC
VRL
VG
VK
VJ
VX
VQ
VZ
VN

9. The material of plastic filter cover for VQ and VFU series is PA. Avoid the adherence of chemicals below to the products, and do not use them under those chemical environments.

● Table Chemical Name

Chemical Name
Methanol
Ethanol
Nitric acid
Sulfuric acid
Hydrochloric acid
Lactic acid
Acetone
Chloroform
Aniline
Trichloroethylene
Hydrogen peroxide

* There are more chemicals which should be avoided. Contact us for the use under chemical circumstance.