

Complex Vacuum Generator with compact and lightweight body, achieving shorter blow-off time to a large extent.

Vacuum Generator **VZ** Series

- *Compact manifold type with lightweight body.*
- *Large volume of blow-off air by air pressure release valve which have achieved to reduce blow-off time.*
- *Bundled wiring of the suction and blow-off solenoid valves.*

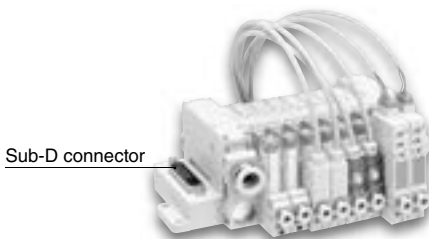

Sub-D connector

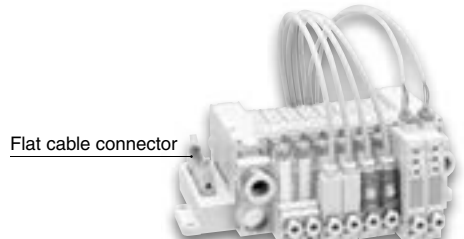

Flat cable connector

Characteristic

- *Wide variety of combinations enables to meet various applications. External Vacuum Controller for a vacuum pump, VZP Series, is also available. (P.378).*
- *2 types of suction valves; Single solenoid type and Double solenoid type*
- *Energy saving. Current consumption of valve is saved at 0.55W*
- *Various kinds of vacuum sensors for wide range of applications*

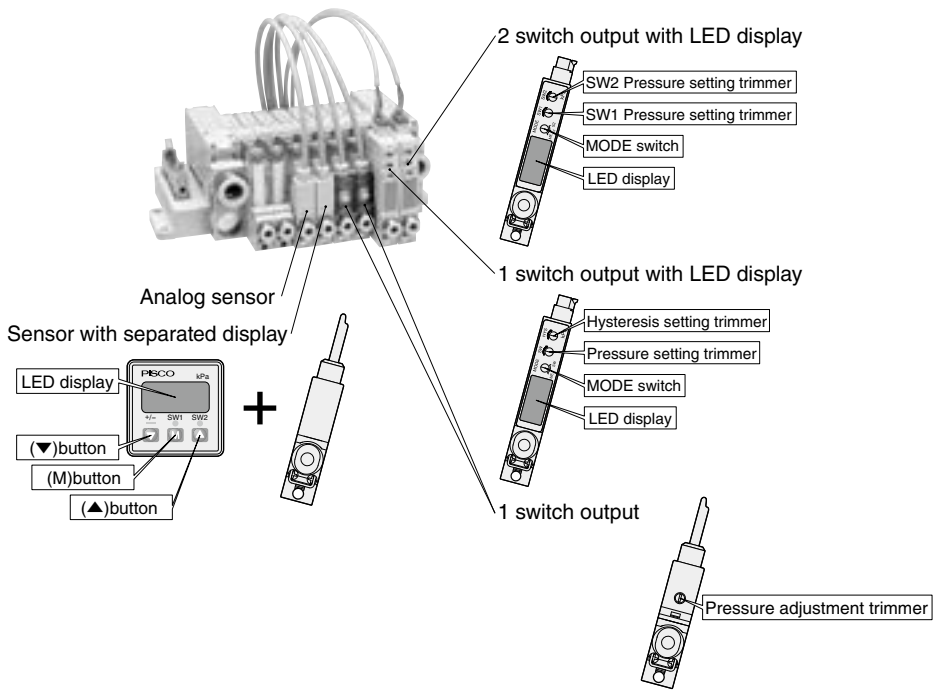

- *User-friendly structure considering easy maintenance*
- *Push-In Fitting and Female thread are standardized on vacuum port.*
- *3 kinds of nozzle bore; $\varnothing 0.5\text{mm}$, $\varnothing 0.7\text{mm}$ and $\varnothing 10\text{mm}$*

■ How double solenoid type works

● At vacuum generation suspended

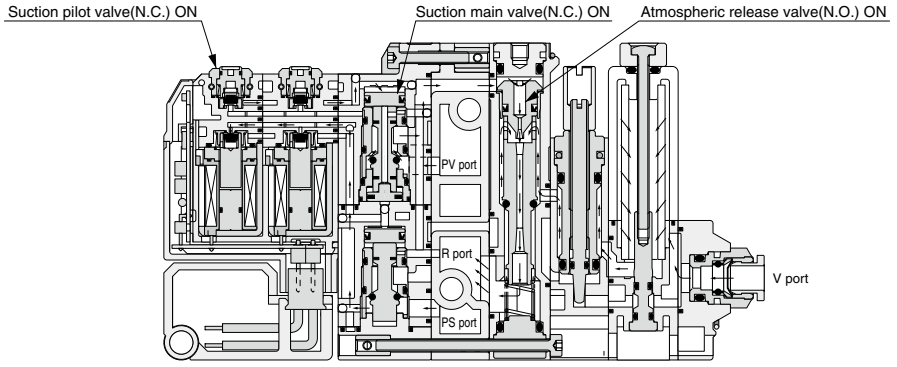

● Vacuum retention

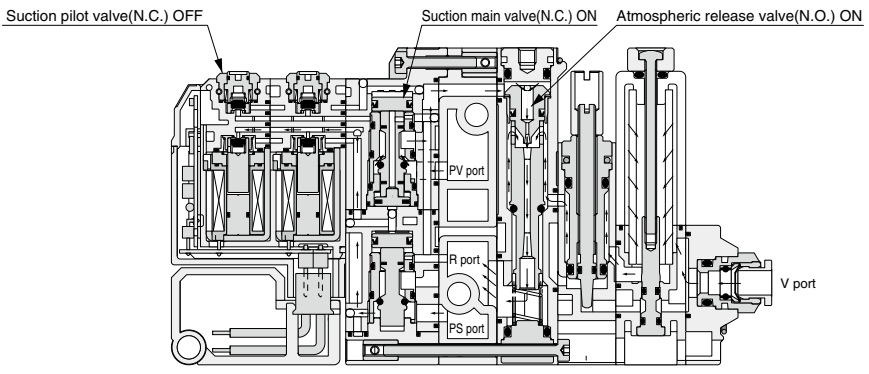

● Blow-off

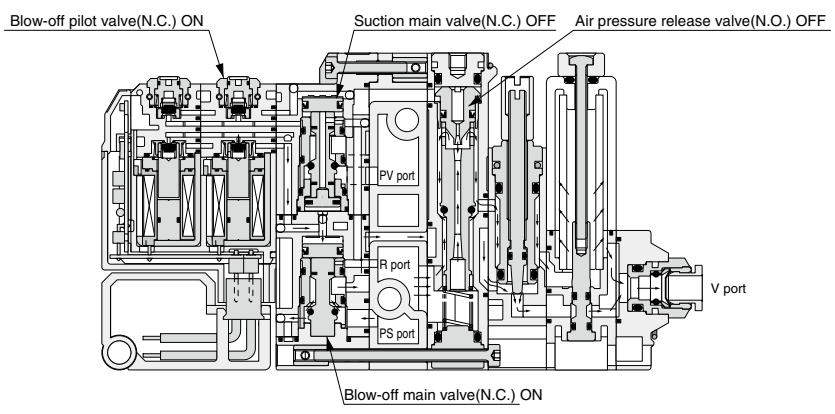

Vacuum Generator Series

Vacuum Generator VZ

Model Code Designation of Manifold Type (Example)

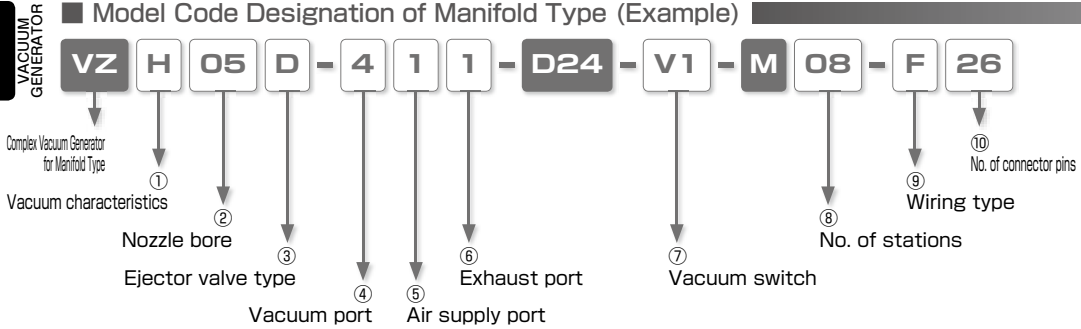

① Vacuum characteristics

Code	Performance	Code	Performance	Code	Performance
H	High-vacuum type (Rated supply pressure : 0.5MPa)	L	Large-flow type (Rated supply pressure : 0.5MPa)	E	High-vacuum at low air supply pressure type (Rated supply pressure : 0.35MPa)
K	When different vacuum characteristics are mixed on a manifold (Fill in the details on Specification Order Form)				

② Nozzle bore

Code	Nozzle bore	Code	Nozzle bore	Code	Nozzle bore
05	0.5mm	07	0.7mm	10	1.0mm
00	When different nozzle bores are mixed on a manifold (Fill in the details on Specification Order Form)				

※ Some combinations of vacuum characteristics ① and nozzle bore ② are not possible. Refer to page 267 for the ejector characteristics.

③ Ejector valve type

Code	Valve type	Code	Valve type	Code	Valve type
No Code	Normally closed type	D	Double solenoid type (Vacuum retention type)	K	Different types on a manifold (specification Order Form Required)

④ Vacuum port

Code	4	Code	6	Code	5
Tube dia.(mm)	ø4 (Push-In Fitting)	Tube dia.(mm)	ø6 (Push-In Fitting)	Thread size.(mm)	M5×0.8 (Female thread)
Code	0				
Tube dia.(mm)	When different ports are mixed on a manifold (Fill in the details on Specification Order Form)				

⑤ Air supply port

Code	4	6	8	1
Tube dia.(mm)	ø4 (Push-In Fitting)	ø6 (Push-In Fitting)	ø8 (Push-In Fitting)	ø10 (Push-In Fitting)

⑥ Exhaust port

Code	S	6	8	1
Exhaust method	Silencer vent	Tube exhaust (ø6mm Push-In Fitting)	Tube exhaust (ø6mm Push-In Fitting)	Tube exhaust (ø10mm Push-In Fitting)

⑦ Vacuum switch

Code	No code	DW
Switch	Without vacuum switch	2 switch output with LED display
Code	DA	S
Switch	Pressure sensor with LED display (Analog output and 1 switch output)	1 switch output without display
Code	V1	V2
Switch	Analog output for negative pressure	Separated type LED pressure display + negative pressure analog sensor
Code	R1	R2
Switch	Compound pressure analog sensor	Separated type LED pressure display + compound pressure analog sensor
Code	K	
Switch	When different switches are mixed on a manifold (Fill in the details on Specification Order Form)	

⑧ No. of stations

Code	02	03	04	05	06	07	08	09	10	11	12
No. of stations	2	3	4	5	6	7	8	9	10	11	12

※ Allowable station numbers of simultaneous operation differs by nozzle size, vacuum performance, and other conditions.
Please contact us for details.

⑨ Wiring type

Code	F	D
Connector	Flat cable connector	Sub-D connector

⑩ No. of connector pins

Code	20	26	25
No. of pins.	20-pin flat cable connector (Max. 9 stations)	26-pin Flat cable connector (Max. 12 stations)	25-pin Sub-D connector (Max. 12 stations)
Code	No code		

No. of pins, Not specified (The suitable connector comes according to wiring type and No. of stations. See below.) (※)

- ※ In case of a flat cable connector
 2 to 4 stations: 10-pin flat cable connector
 5 to 9 stations: 20-pin flat cable connector
 10 to 12 stations: 26-pin flat cable connector
 In case of a sub-D connector
 2 to 4 stations: 9-pin Sub-D connector
 5 to 12 stations: 25-pin Sub-D connector

Model Designation of Manifold-base Only (Example)

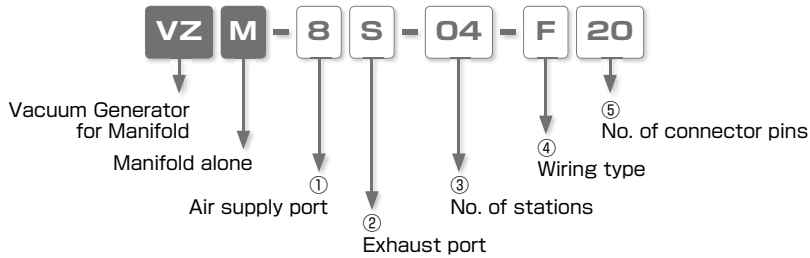

① Air supply port (Applicable tube size)

Code	4	6	8	1
Tube dia.(mm)	ø4 (Push-In Fitting)	ø6 (Push-In Fitting)	ø8 (Push-In Fitting)	ø10 (Push-In Fitting)

② Exhaust port

Code	S	6	8	1
Exhaust method	Silencer vent	Tube exhaust (ø6mm Push-In Fitting)	Tube exhaust (ø6mm Push-In Fitting)	Tube exhaust (ø10mm Push-In Fitting)

③ No. of stations

Code	02	03	04	05	06	07	08	09	10	11	12
No. of stations	2	3	4	5	6	7	8	9	10	11	12

④ Wiring type

Code	F	D
Connector	Flat cable connector	Sub-D connector

⑤ No. of connector pins

Code	20	26	25
No. of pin.	20-pin Flat cable connector (Max. 9 stations)	26-pin Flat cable connector (Max. 12 stations)	25-pin Sub-D connector (Max. 12 stations)
Code	No code		
No. of pin.	Not specified (The suitable connector comes according to wiring type and No. of stations. See below.) (※)		

※ In case of a flat cable connector

- 2 to 4 stations: 10-pin Flat cable connector
- 5 to 9 stations: 20-pin Flat cable connector
- 10 to 12 stations: 26-pin Flat cable connector

In case of a sub-D connector

- 2 to 4 stations: 9-pin Sub-D connector
- 5 to 12 stations: 25-pin Sub-D connector

■ Model Designation of Mounting Valve Unit (Example)

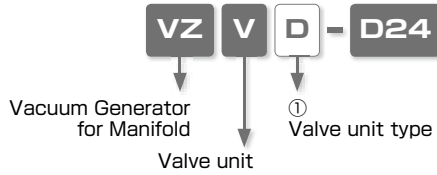

① Valve unit type

Code	No Code	D
Valve unit type	Normally closed type	Double solenoid type (Vacuum retention type)

■ Model Designation of Manifold Installation Top-Mounting Unit alone (Example)

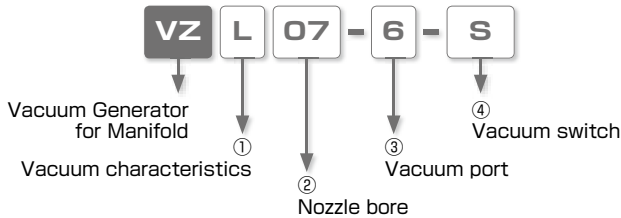

① Vacuum characteristics

Code	Performance	Code	Performance	Code	Performance
H	High-vacuum type (Rated supply pressure : 0.5MPa)	L	Large-flow type (Rated supply pressure : 0.5MPa)	E	High-vacuum at low air supply pressure type (Rated supply pressure : 0.35MPa)

② Nozzle bore

Code	Nozzle bore	Code	Nozzle bore	Code	Nozzle bore
05	0.5mm	07	0.7mm	10	1.0mm

③ Vacuum port

Code	4	Code	6	Code	5
Tube dia.(mm)	ø4 (Push-In Fitting)	Tube dia.(mm)	ø6 (Push-In Fitting)	Thread size(mm)	M5×0.8 (Female thread)

④ Vacuum switch

Code	No code	DW
Sensor	Without vacuum switch	2 switch output with LED display
Code	DA	S
Sensor	Pressure sensor with LED display (Analog and 1 switch output)	1 switch output without display
Code	V1	V2
Sensor	Analog output for negative pressure	Separated type LED pressure display + negative pressure analog sensor
Code	R1	R2
Sensor	Compound pressure analog sensor	Separated type LED pressure display + compound pressure analog sensor

Vacuum Generator Series

Vacuum Generator VZ

VACUUM GENERATOR

■ Specification Order Form (example)

		Vacuum characteristics	Nozzle bore	Ejector valve type	-	Vacuum port (V)	Air supply port (PV)	Exhaust port (R)	-	Voltage (V)	-	Vacuum switch	-	No. of stations	Wiring type	No. of connector pins
		①	②	③	-	④	⑤	⑥	-	(V)	-	⑦	-	⑧	⑨	⑩
VZ		K	00	K	-	0	1	1	-	D24	-	K	-	08	F	20
L	↑	St.1	H	05	-	4			-		-		-			
		St.2	H	05	-	4			-		-		-			
		St.3	H	05	-	4			-		-	V1	-			
		St.4	L	07	D	4			-		-	V1	-			
		St.5	L	07	D	4			-		-	S	-			
St. no.		St.6	L	07	D	4			-		-	S	-			
		St.7	E	10	-	4			-		-	DA	-			
		St.8	E	10	-	4			-		-	DA	-			
		St.9			-				-		-		-			
		St.10			-				-		-		-			
		St.11			-				-		-		-			
R	↓	St.12			-				-		-		-			

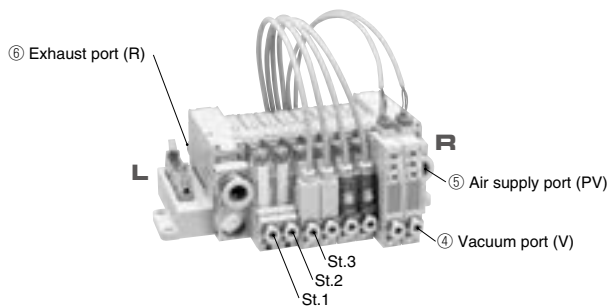

※ Station no. is arranged St.1, St.2 ... St.12 from L side.

Vacuum Generator VZ Series Specification Order Form

To: NIHON PISCO CO., Ltd.

Name : _____

Order No. : _____

Date : _____

Requested EX-W PISCO Date : _____ Quantity : _____

	Vacuum characteristics	Nozzle bore	Ejector valve type	-	Vacuum port (V)	Air supply port (PV)	Exhaust port (R)	-	Voltage (V)	-	Vacuum switch	-	No. of stations	Wiring type	No. of connector pins
	①	②	③		④	⑤	⑥				⑦		⑧	⑨	⑩
VZ				-				-	D24	-		-			
L	St.1			-				-		-		-			
↑	St.2			-				-		-		-			
	St.3			-				-		-		-			
	St.4			-				-		-		-			
	St.5			-				-		-		-			
St. no.	St.6			-				-		-		-			
	St.7			-				-		-		-			
	St.8			-				-		-		-			
	St.9			-				-		-		-			
	St.10			-				-		-		-			
↓	St.11			-				-		-		-			
R	St.12			-				-		-		-			

- ※ 1. Refer to the previous page to fill in the form.
- ※ 2. Copy this page and use.
- ※ 3. Use this specification order form when ordering different specifications of mounting units on a manifold.

■ Construction

● Without vacuum pressure sensor type

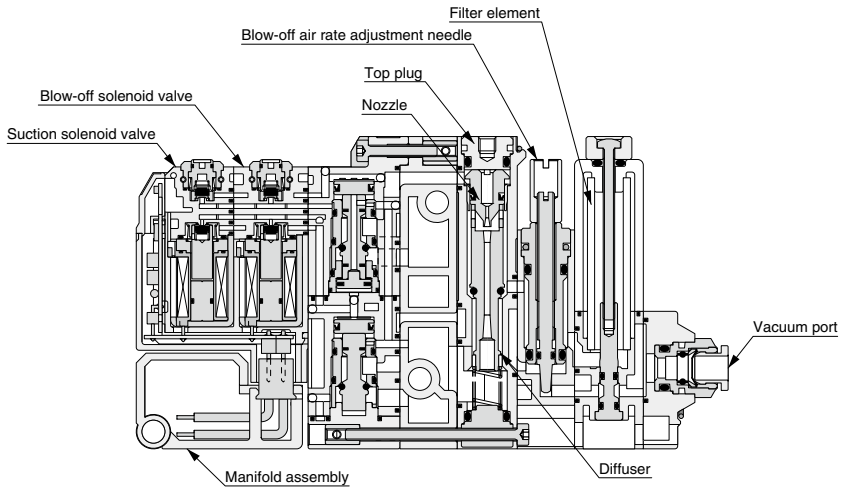

● Analog sensor type

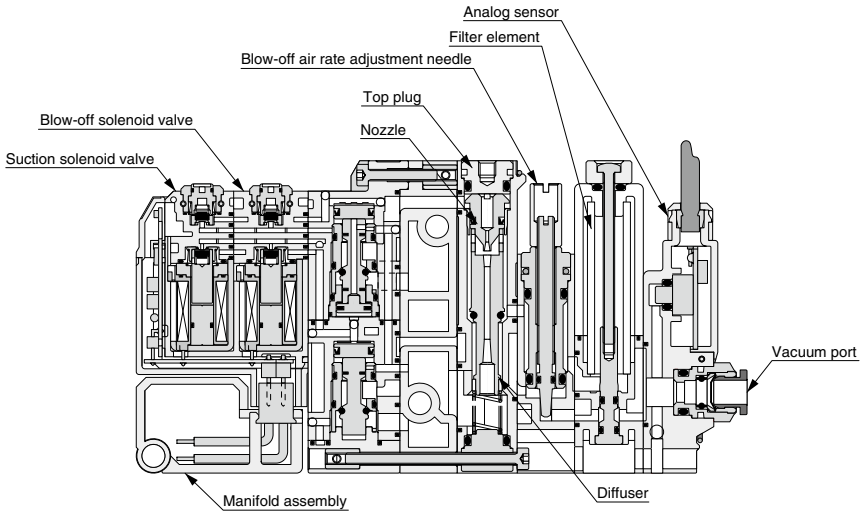

● 1 switch output sensor type

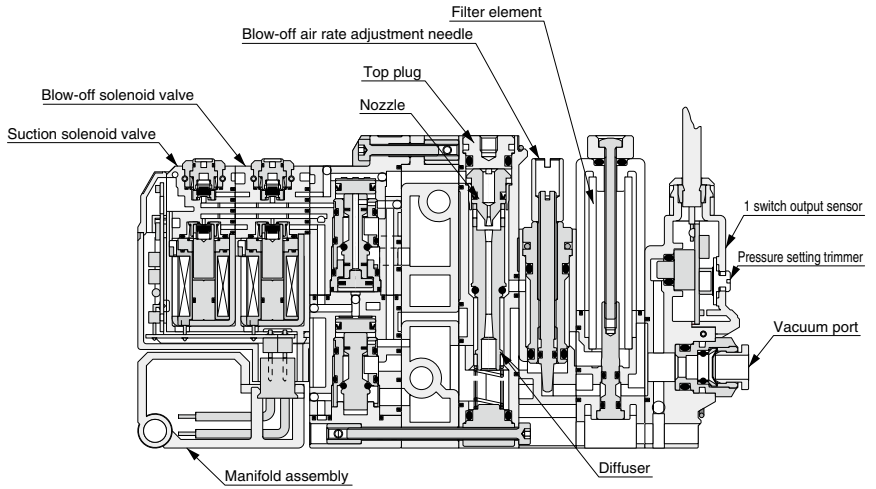

● Vacuum pressure sensor with LED display type

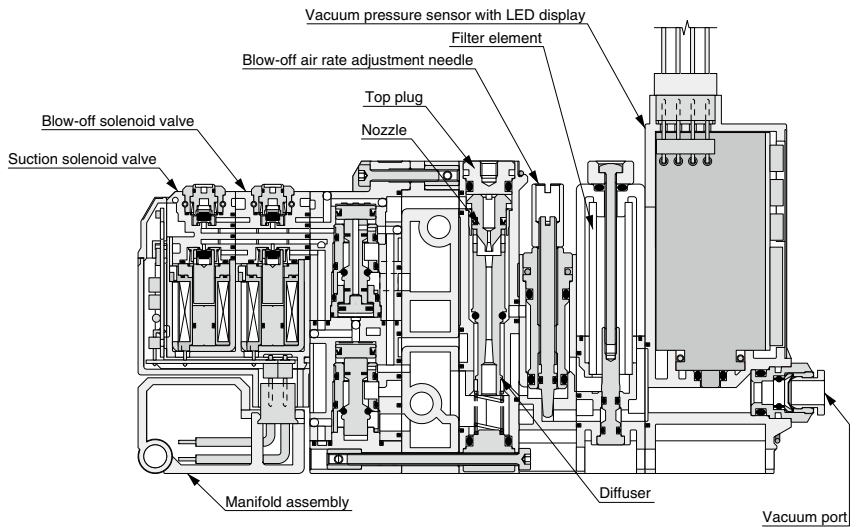

Vacuum Generator Series

Vacuum Generator VZ

VACUUM GENERATOR

■ Specification (Supply pressure)

Fluid medium	Air
Operating pressure range	0.3 ~ 0.7 MPa
Rated supply pressure	H and L type : 0.5 MPa, E type : 0.5 MPa
Operating temp. range	5 ~ 50°C

■ Ejector specification

Model code	Nozzle bore (mm)	Rated supply pressure (MPa)	Final vacuum (-kPa)	Suction flow (ℓ/min(ANR))	Air consumption (ℓ/min(ANR))
VZH05	0.5	0.5	90.4	7	11.5
VZL05			66.5	12	
VZH07	0.7	0.5	93.1	13	23
VZL07			66.5	24	
VZE07		0.35	90.4	10	
VZH10	1.0	0.5	93.1	24	46
VZE10		0.35	90.4	20	34

■ Solenoid valve (Suction solenoid valve / Blow-off solenoid valve)

■ Pilot valve

Item	Suction solenoid valve	Blow-off solenoid valve
Operating system	Direct operation	
Valve construction	Elastic seal, Poppet valve	
Rated voltage	DC24V	
Allowable voltage range	DC21.6 ~ DC26.4V	
Surge protection circuit	Surge absorber	
Power consumption	0.55W (With LED)	
Operation indicator	Coil excitation: Red LED ON	Coil excitation: Yellow-green LED ON
Manual operation	Push & lock type	
Wiring method	Sub-D connector / Flat cable connector	

■ Switchover valve

Item	Suction solenoid valve	Blow-off solenoid valve	
Operating system	Pilot valve-activated indirect action		
Valve construction	Elastic seal, Poppet valve		
Valve function	Single solenoid	Double solenoid / Single solenoid	
Valve unit type	N.C. (Normally closed)		
Proof pressure	1.05MPa		
Lubrication	Not required		
Effective sectional area (Cv)	4.5mm ² (0.24)	3.5mm ² (0.19)	
Response time	OFF → ON	10msec	10msec
	ON → OFF	15msec	10msec

267

VH VS

VU

VUM

VY

VB

VM VC

VRL

VG

VK

VJ

VX

VQ

VZ

Vacuum switch

Specification		With LED display		No display	Separated display with analog	Analog
		2 switch output	1 switch output	1 switch output	1 switch output	
Item		2 switch output	1 switch output	1 switch output	1 switch output	Analog
Current consumption		40mA		20mA	50mA	20mA
Pressure detection		Diffused semiconduction pressure switch				Diffused semiconduction pressure switch
Operating pressure range		-100 ~ 0kPa				-100 ~ 0kPa
Pressure setting range		-99 ~ 0kPa				-999 ~ 999counts
Proof pressure		0.2MPa				0.2MPa
Operating temp. range		0 ~ 50°C (No freezing)		-10 ~ 60°C (No freezing)	-10 ~ 50°C (No freezing)	-10 ~ 60°C (No freezing)
Operating humidity range		35 ~ 85%RH (No dew condensation)				
Rated voltage		12 ~ 24VDC ±10% Ripple (P-P) 10% max.		DC10.8 ~ 30V (Ripple voltage included)		
Protective structure		IEC standard IP40 equiv.				
No. of switch output		2	1		2	
Switching action accuracy		±3%F.S. max. (at Ta=25°C)				
Differential accuracy		Fixed	Variable	Fixed	Variable	
Switch output		NPN open collector				
Analog output	Output voltage	1 ~ 5V		1 ~ 5V		
	Zero-point voltage	1±0.1V		1±0.1V		
	Span voltage	4±0.1V		4±0.1V		
	Output current	1mA max.		0.5mA max.	1mA max.	
	LIN/HYS	±0.5%F.S. max.		±0.5%F.S. max.		
Indication		0 ~ -99kPa (2-digit red LED display)			3-digit red LED display	
Display frequency		About 4 times/sec.			About 4 times/sec.	
Indication accuracy		±3%F.S. ±2 digit			±1%F.S.	
Sensor resolution		1 digit			1 digit	
Operational indication		SW1: Red LED turns ON, when pressure is above setting. SW2: Green LED turns ON, when pressure is above setting.			SW1: Green LED turns ON, when pressure is above setting. SW2: Red LED turns ON, when pressure is above setting.	

Filter specification

Element material	PVF (Polyvinyl formal)
Filtering capacity	10µm
Filter surface area	660mm²

Blow-off function

Item	Blow-off valve	
Blow-off air rate	0 ~ 50l/min(ANR) (Supply pressure: 0.5MPa)	
Air pressure release valve	Operating system	Pilot valve-activated indirect action
	Valve construction	Elastic seal, Poppet valve
	Valve type	N.O. (Normally open)
	Lubrication	Not required
	Orifice bore	Equivalent to 35mm

Vacuum Generator Series

Vacuum Generator VZ

VACUUM GENERATOR

■ Circuit diagram

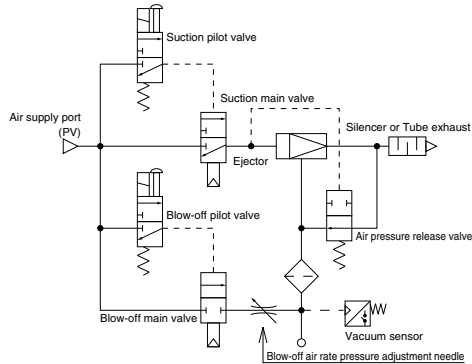

Normally closed type

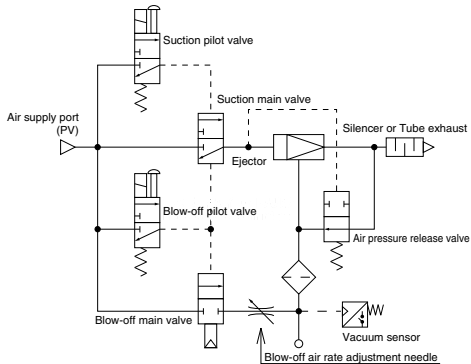

Double solenoid type

■ Circuit diagram(Solenoid valve)

● Sub-D connector

9-pin

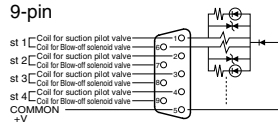

25-pin

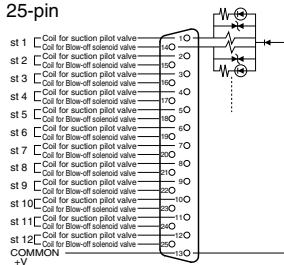

● Flat cable connector

10-pin

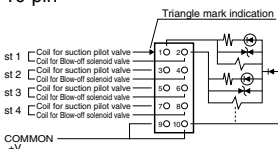

(Note: Common (+V) pins No. 9 and 10 are short-circuited inside.)

20-pin

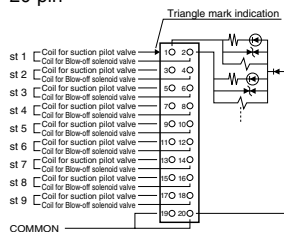

(Note: Common (+V) pins No.19 and 20 are short-circuited inside.)

26-pin

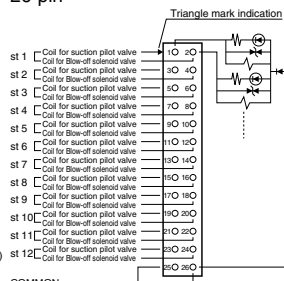

(Note: Common (+V) pins No.25 and 26 are short-circuited inside.)

269

VH VS

VU

VUM

VY

VB

VW VC

VRL

VG

VK

VJ

VX

VQ

VZ

Characteristics

Supply pressure - Final vacuum, Suction Flow, Air Consumption

VZH05, VZL05

Vacuum characteristics

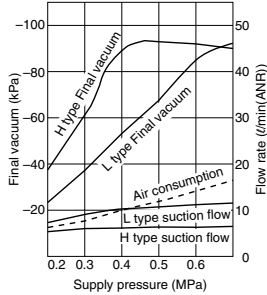

Flow characteristics

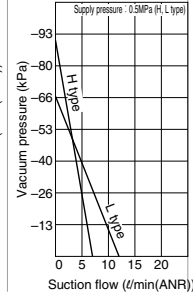

VZH07, VZL07, VZE07

Vacuum characteristics

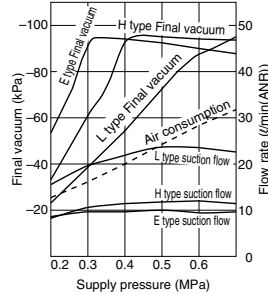

Flow characteristics

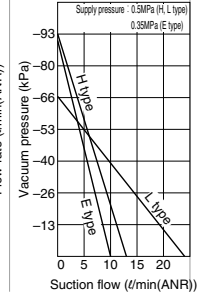

VZH10, VZE10

Vacuum characteristics

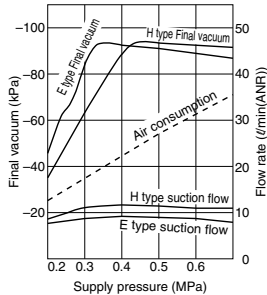

Flow characteristics

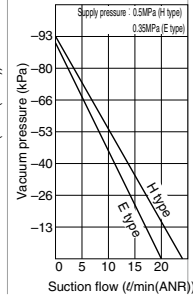

1. In the characteristics shown above, supply pressures refer to those when vacuum is generated.
2. In the characteristics shown above, an odd noise may be heard when supply pressures are immediately before the peak of vacuum levels (H (High vacuum) type: 0.4-0.45MPa, and E (High-vacuum at low air supply pressure type) type: 0.29-0.32MPa). The sounding of this odd noise means the characteristics are unstable. If nothing is done, the sound may become even noisier. This situation can also adversely affect the sensor, resulting in a malfunction or trouble. So reset the supply pressure.
(Ex. 1: When the vacuum generator H type is in operation with the original pressure of 0.5MPa, the odd noise began to be heard due to a drop in supply pressure to 0.43MPa. Reset the supply pressure for the vacuum generator in operation at 0.5MPa.)
3. Piping design and equipment selection should be made with an effective sectional area being 3 times as large as the nozzle diameter as a standard. Satisfactory vacuum characteristics are not obtained unless sufficient supply air flow is secured. (For example, the odd noise is heard even when pressure is at the set value, suction flow is insufficient, the final vacuum does not satisfy the required level, etc.)
(Example2. There is the odd noise from the vacuum generator H type, though the supply pressure is 0.5MPa. → Insufficient supplied air rate is the cause. The supplied air rate is reduced before the vacuum generator by a pipe resistance, and a proper air rate is not obtained. Select tubes and pneumatic apparatuses with the target effective cross-section areas obtaining the necessary air flow rate.)
(Example3. When $\varnothing 1.0\text{mm}$ of nozzle bore is selected, the effective cross-section size should be more than 2.35mm^2 . (cross-section $0.5 \times \pi \times 0.785\text{mm}^2 \times 3 = 2.35\text{mm}^2$). Select tubes and pneumatic apparatuses with the effective cross-section area more than 2.3mm^2 .)

■ Applicable Tube and Related Products

Polyurethane Tube

(Piping products catalog P.596)

- Polyurethane Tube is for the general pneumatic piping and suitable for a compact piping.

Nylon Tube

(Piping products catalog P.608)

- Nylon Tube is for the general pneumatic piping and suitable for a high-pressure fluid up to 1.5MPa (NB tube: 1.0MPa).

Vacuum Tube

(Piping products catalog P.612)

- Vacuum Tube is a ultra-soft tube and suitable for piping of vacuum generators or actuators.

Vacuum Pads

- Vacuum Pad Standard Series . . . P.428
- Vacuum Pad Sponge Series . . . P.468
- Vacuum Pad Bellows Series . . . P.488
- Vacuum Pad Multi-Bellows Series P.508
- Vacuum Pad Oval Series P.526
- Vacuum Pad Soft Series P.550
- Vacuum Pad Soft Bellows Series · P.578
- Vacuum Pad Skidproof Series . . P.604
- Vacuum Pad Ultrathin Series . . . P.624
- Vacuum Pad Mark-free Series . . P.642
- Vacuum Pad Long Stroke Series · P.658

VZ Tube exhaust, Sub-D connector type



Model code : VZ□□□-□□□-D24-□-M□-D□

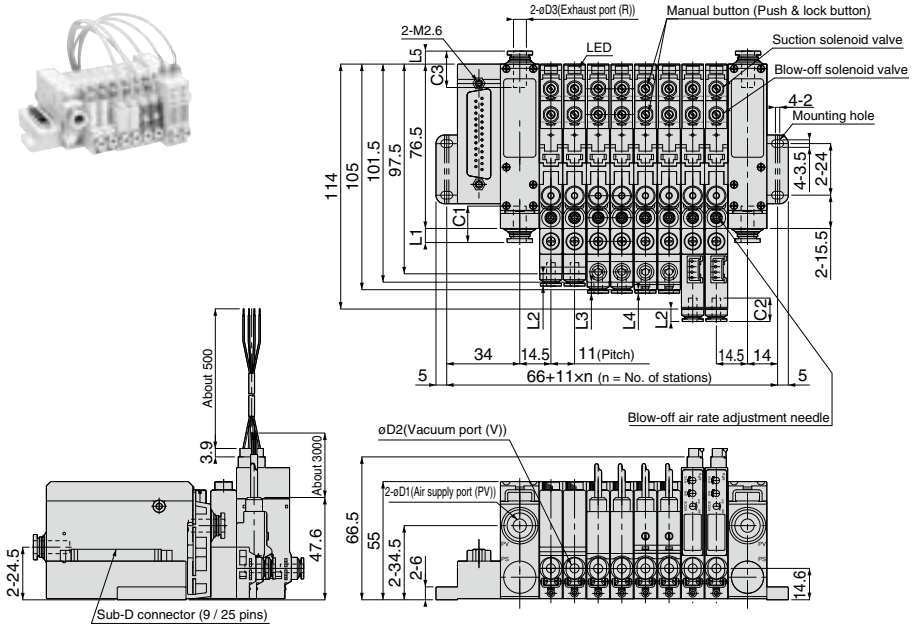
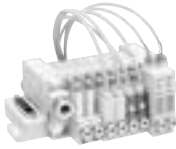

Dimension of Fitting

Unit : mm

Air supply port (PV) øD1	C1	L1	Vacuum port (V) øD2	C2	L2	L3	L4	Exhaust port (R) øD3	C3	L5
4	14.9	2	4	10.9	5.8	5.1	1.6	6	17	6.1
6	17	6.6	6	8.8	8.7	8	4.5	8	18.2	7.6
8	18.2	8.1	6 (Female thread)	-	4	3.3	-0.2	10	20.7	11.2
10	20.7	11.7								

Vacuum Generator Series

Vacuum Generator VZ

VZ Silencer vent, Sub-D connector type



Model code : VZ□□□-□□S-D24-□-M□-D□

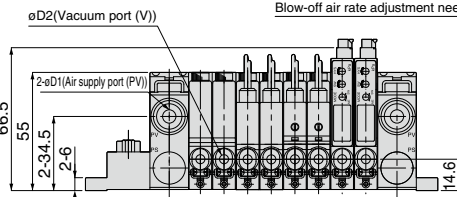
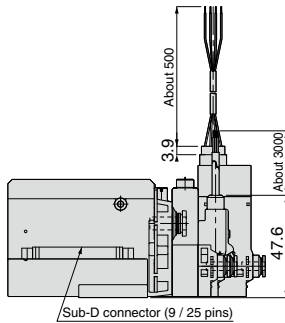
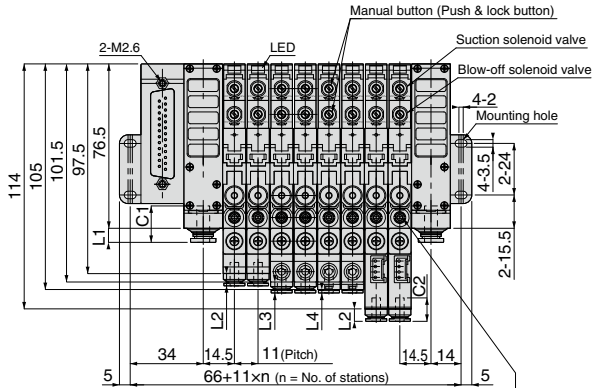
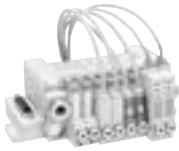

Dimension of Fitting

Dimension of Fitting								Unit : mm
Air supply port (PV) øD1	C1	L1	Vacuum port (V) øD2	C2	L2	L3	L4	
4	14.9	2	4	10.9	5.8	5.1	1.6	
6	17	6.6	6	8.8	8.7	8	4.5	
8	18.2	8.1	M5 (Female thread)	-	4	3.3	-0.2	
10	20.7	11.7						

273

VH - VS

VU

VUM

VY

VB

VM - VC

VRL

VG

VK

VJ

VX

VQ

VZ



VZ Tube exhaust, Flat cable connector type

Chart P.270

Model code : VZ□□□-□□□-D24-□-M□-F□

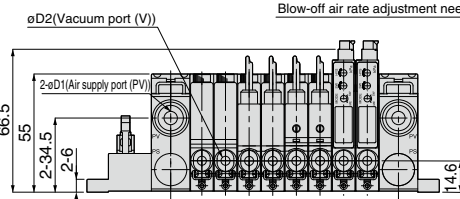
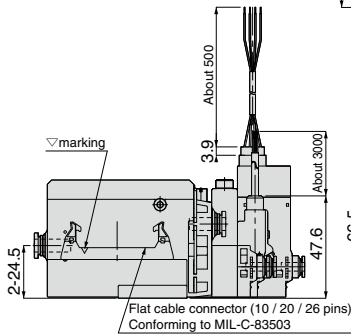
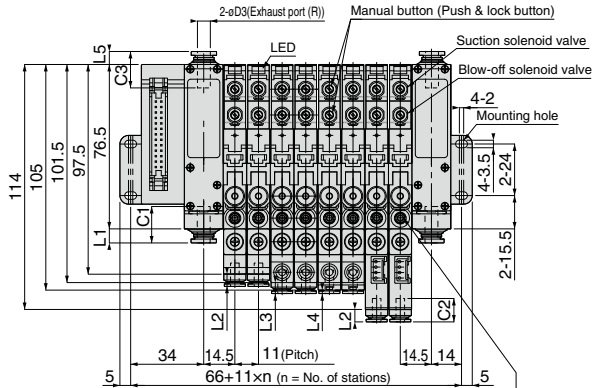
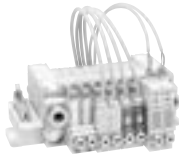

Dimension of Fitting

Unit : mm

Air supply port (PV) øD1	C1	L1	Vacuum port (V) øD2	C2	L2	L3	L4	Exhaust port (R) øD3	C3	L5
4	14.9	2	4	10.9	5.8	5.1	1.6	6	17	6.1
6	17	6.6	6	8.8	8.7	8	4.5	8	18.2	7.6
8	18.2	8.1	M5 (Female thread)	-	4	3.3	-0.2	10	20.7	11.2
10	20.7	11.7								

VACUUM GENERATOR
EXTERNAL VACUUM CONTROLLER
VACUUM PAD
VACUUM ACCESSORIES

Vacuum Generator Series

Vacuum Generator VZ

VACUUM GENERATOR

VZ Silencer vent, Flat cable connector type

Chart P.270

Model code : VZ□□□-□□S-D24-□-M□-F□

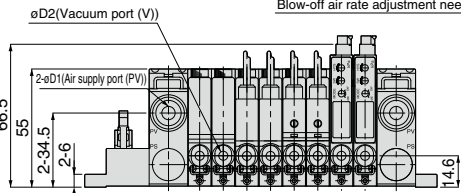
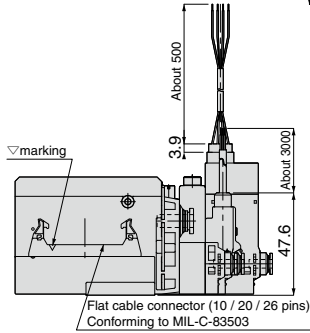
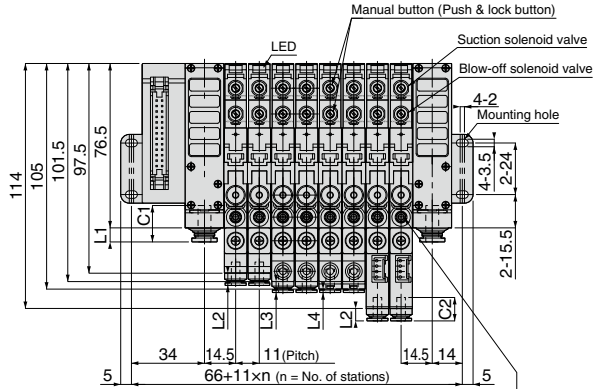
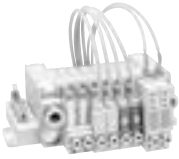

Dimension of Fitting

Unit : mm

Air supply port (P.V) øD1	C1	L1	Vacuum port (V) øD2	C2	L2	L3	L4
4	14.9	2	4	10.9	5.8	5.1	1.6
6	17	6.6	6	8.8	8.7	8	4.5
8	18.2	8.1	M6 (Female thread)	-	4	3.3	-0.2
10	20.7	11.7					

275

VH - VS

VU

VUM

VY

VB

VM - VC

VRL

VG

VK

VJ

VX

VQ

VZ

△ Detailed Safety Instructions

Before using PISCO products, be sure to read "Safety Instructions" and "Safety Instruction Manual" on page 35-39 and "Common Safety Instructions for Vacuum Series" on page 47-49.

Warning

- For the operation of the valve, make sure that the leakage current is less than 1mA. Leakage current larger than that may cause malfunction.
- The coil in a pilot solenoid valve generates heat under the following ① to ③ conditions. The heat may cause dropping life cycle, malfunctions, getting burnt or damaging peripheral machines.
Contact us when the power is applied to the vacuum generator under the following conditions:
 - The power is continuously ON for over 2 hours.
 - High-cycle operation.
 - Even when intermittent running of the generator is carried out, the total operation time per day is longer than non-operation time.
- When the electricity is applied to valves continuously for a long time, the coils generate heat. It may cause dropping life cycle, malfunctions, getting burnt or damaging peripheral machines due to the heat.
- Switchover valve of double-solenoid types (VZ □ D···) is placed in neutral after the supply of pilot air has been suspended (the same is true when the valve is being operated for the first time after shipment). When resuming the supply of pilot air, be sure to send a signal to the pilot valve, or conduct switchover operations manually as required.
- When a mounting unit is removed from a manifold-base, make sure the residual air is exhausted completely.
- Avoid excessive vibration and impact on the vacuum generator. Otherwise, it may cause malfunctions or damaging. (Operate the product with acceleration less than 49m/s²)
- When double solenoid type (VZ □ D···) is operated under vibrating condition, set the main valves at right angles to vibrating direction.

Caution

- Do not give an excessive tensile strength and bending on a lead wire. Otherwise, breaking wire or damage on connector may be caused.
- Compressed air contains many kinds of drains such as water, oxidized oil, tar and other foreign substances. Dehumidify the compressed air by using an after-cooler or a dryer and improve the air quality, since those drains seriously impair the performance of the vacuum generator.
- Do not use lubricators.
- Foreign substances such as rusts or dust in the pipes may cause malfunction. Place a filter finer than 5μm ahead of the air supply port. It is recommended to carry out pipe flushing before operation and on a proper regular basis.
- Avoid using the vacuum generator under the condition of corrosive and / or inflammable gas. Also do not use these gasses as a fluid medium.
- When replacing supply ports and vacuum ports cartridges, be sure to remove foreign substances sticking to cartridge seals; make sure cartridge fixing pins are properly inserted into the appropriate ports. Read "Safety Rules for Use" before replacement.
- Carry out the maintenance of the clogging of silencer element on manifold base periodically. It may cause dropping the performance or troubles by the clogging.
- When installing each mounting unit on a manifold, be sure to remove any foreign substances sticking to seals; make sure cartridge fixing pins are properly inserted into the appropriate ports. Read "Safety Rules for Use" before replacement.
- Arrange connector wiring of Sub-D or Flat cable correctly, after understanding the circuit well.
- Read and understand "Safety Rules for Manifold Type" before operation, since manifold type may have a performance drop or some troubles by use condition.
- Although the exhaust of the model with a manifold type is silencer vent by each individual unit, the exhaust air of operating unit or blow-off air flows into the vacuum port of non-operating unit. If such exhaust air causes the problem, please contact PISCO.

⚠ Safety Rules for Use

1. Safety Rules for Manifold Type

The increase of manifold station may cause troubles such as performance drop by a shortage of air supply and insufficient capability to exhaust, and exhaust air leak to the vacuum port. Allowable manifold numbers of simultaneous operation differs by nozzle size, vacuum performance, and other conditions. Please contact us for details.

1. Drop in the vacuum performance due to the supplied air shortage.
 - Countermeasures : ① Check the supplied air volume.
 - ② Arrange the piping length as short as possible.
 - ③ Use fittings with large size.
2. Drop in the vacuum performance due to insufficient exhaust volume, or exhaust air leaking out through the vacuum port.
 - Cause : Insufficient volume of the silencer or piping makes exhaust resistance large and it results in impairing the vacuum performance.
 - Countermeasures : ① In case of silencer vent type, set an external silencer.
 - ② In case of tube exhaust type, use wider and shorter pipes for exhaustion.
 - ③ Avoid any obstacles around the exhaust ports.
 - ④ Reduce the number of mounting units which operate simultaneously.

2. How to install the product

When a vacuum generator is operated under a vibration condition, install the vacuum generator so that the main valves are at right angle to vibrating direction of application.

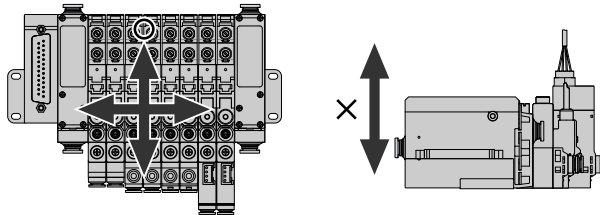

3. Handling Method of Vacuum Switch

- Refer to page 825 (Small Pressure Sensor) for handling of vacuum sensor "V1" , "V2" , "R1" and "R2" .
- Refer to page 815 (LED Digital Pressure Sensor) for handling of vacuum sensor "DW" and "DA" .

4. How to adjust Blow-off Air

Turn the blow-off air rate adjustment needle to the right (clockwise) to reduce blow-off air and to the left (counterclockwise) to increase. After adjusting the needle, tighten the locknut firmly with 0.1-0.3Nm of the tightening torque.

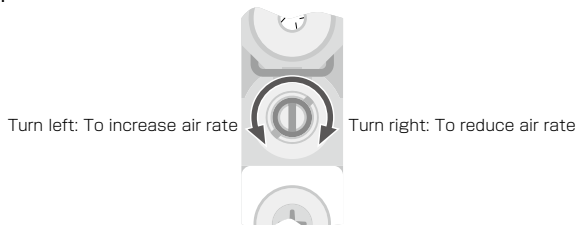

5. How to replace Filter Elements

- Remove the fixing screw to replace filter elements. Make sure to place the filter seal rubber properly and tighten the screw to fix the filter cover with 0.3-0.5Nm of the tightening torque after the replacement.

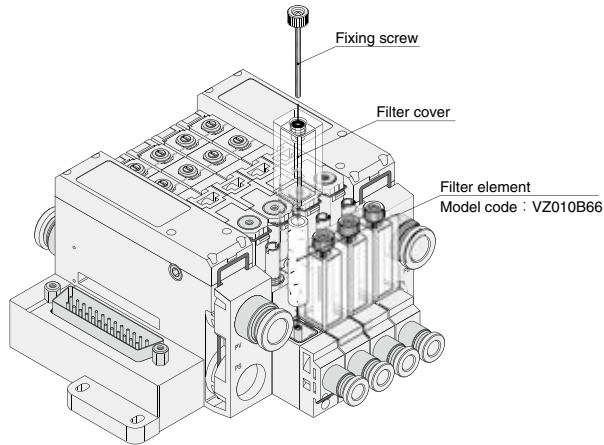

6. How to replace Silencer Elements

- Replace silencer elements by the following method.

- Remove 6 fixing screws to take out the silencer cover.
- Take out a silencer element.
- Install a new element and place the cover to the original position. Tighten the screws with 0.4-0.5Nm of the tightening torque.

(Note) The fixing screws are tapping screws for resin. Use a precision driver to check the initial mesh and tighten screws.

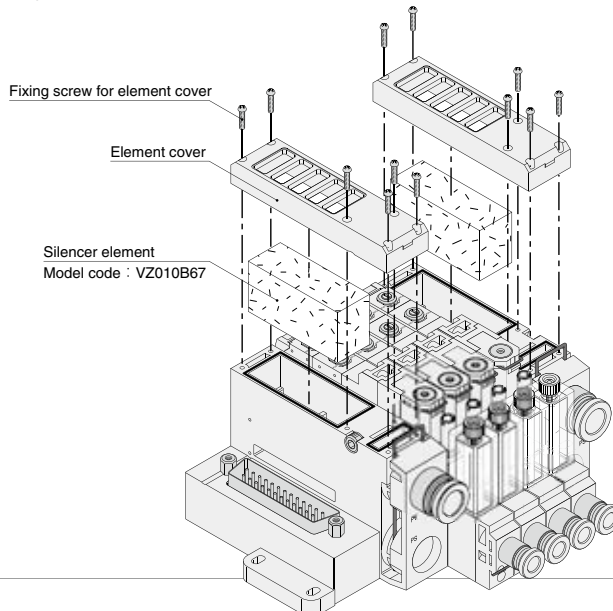

7. How to replace and clean Nozzles and Diffusers

■ Clean the nozzle and the diffuser following the instructions below.

- ① Remove the fixing pin on the ejector body with a flathead screwdriver.
- ② Pull out top plug, nozzle and diffuser.
- ③ Remove the foreign substances adhered to nozzle and diffuser inside and seal rubbers by air blowing or wiping.

(Note) Pay special attention not to damage inside of nozzle & diffuser and seal rubbers.
- ④ Apply grease on piston packing of nozzle and diffuser if necessary.

(Note1) If grease on the packing is found scattered around seal rubbers, apply a thin layer of grease on the entire circumference of the packing. Select the grease which does not damage rubber and resin.

(NOK KLUBER CO., LTD. "ISOFLEX TOPAS NB52" is recommended.)

(Note2) Apply grease with care since it will cause dust and/or fluff to adhering to the packing section.
- ⑤ Place back diffuser, nozzle and top plug into the unit in this order.
- ⑥ Insert the fixing pin to fix the top plug.

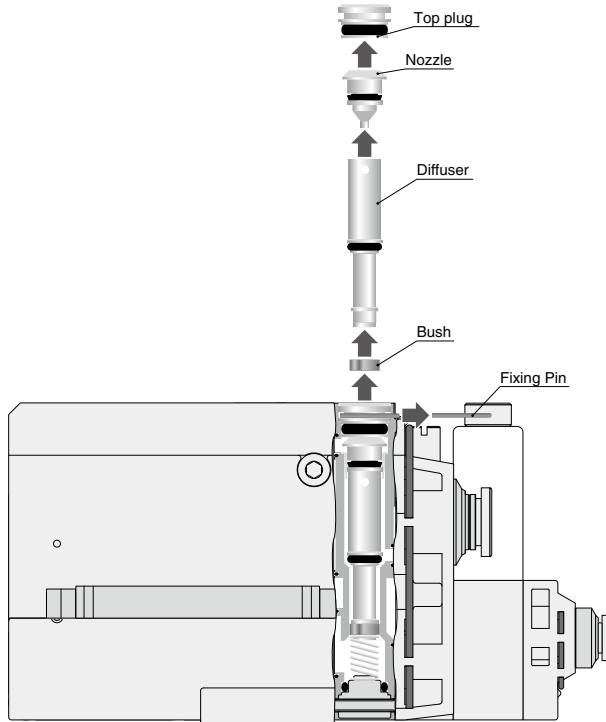

8. How to install and uninstall Mounting Unit

[How to uninstall]

Uninstall mounting units from the manifold by the following instructions.

- ① Stop the air supply and release all pressure in piping.
- ② Remove 2 fixing screws with a proper tool.
- ③ Uninstall mounting units from the manifold.

[How to install]

- ① Make sure that seal rubbers are in the proper positions and there is no foreign substance adhered to the connecting parts.
- ② Install each mounting unit on the manifold.
- ③ Make sure that the units are properly fit into the manifold.
- ④ Tighten 2 fixing screws with a proper tool.

(Note) Slowly and alternately tighten 2 fixing screws.
Recommended tightening torque: 0.4-0.5Nm~0.5N·m

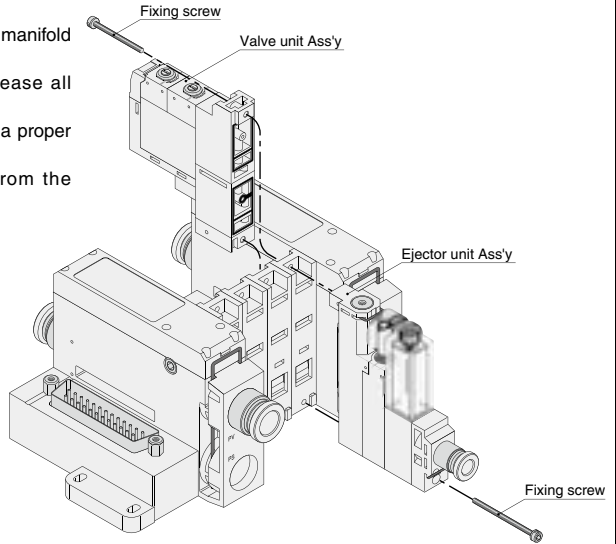

9. How to replace Cartridge Fittings

Replace cartridge fittings following the instructions below.

- ① Use a flathead screwdriver to pull out a fixing pin.
- ② Pull out a cartridge fitting.

(Note) When a new cartridge fitting is attached, check if there are no dusts or fluffs stuck on O-ring.

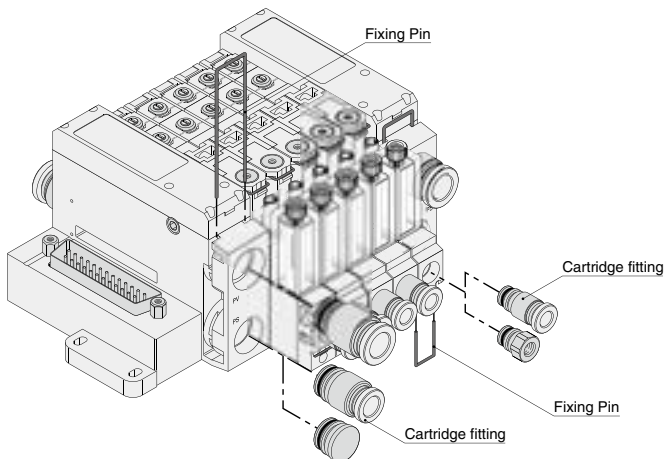



Vacuum Generator Series

Vacuum Generator VZ

VACUUM
GENERATOR

281

VH - VS

VU

VUM

VY

VB

VM - VC

VRL

VG

VK

VJ

VX

VQ

VZ



SAFETY Instructions

This safety instructions aim to prevent personal injury and damage to properties by requiring proper use of PISCO products.

Be certain to follow ISO 4414 and JIS B 8370

ISO 4414 : Pneumatic fluid power...Recommendations for the application of equipment to transmission and control systems.

JIS B 8370 : General rules and safety requirements for systems and their components.

This safety instructions is classified into "Danger", "Warning" and "Caution" depending on the degree of danger or damages caused by improper use of PISCO products.



Danger

Hazardous conditions. It can cause death or serious personal injury.



Warning

Hazardous conditions depending on usages. Improper use of PISCO products can cause death or serious personal injury.



Caution

Hazardous conditions depending on usages. Improper use of PISCO products can cause personal injury or damages to properties.



Warning

1. Selection of pneumatic products

- ① A user who is a pneumatic system designer or has sufficient experience and technical expertise should select PISCO products.
- ② Due to wide variety of operating conditions and applications for PISCO products, carry out the analysis and evaluation on PISCO products. The pneumatic system designer is solely responsible for assuring that the user's requirements are met and that the application presents no health or safety hazards. All designers are required to fully understand the specifications of PISCO products and constitute all systems based on the latest catalog or information, considering any malfunctions.

2. Handle the pneumatic equipment with enough knowledge and experience

- ① Improper use of compressed air is dangerous. Assembly, operation and maintenance of machines using pneumatic equipment should be conducted by a person with enough knowledge and experience.

3. Do not operate machine / equipment or remove pneumatic equipment until safety is confirmed.

- ① Make sure that preventive measures against falling work-pieces or sudden movements of machine are completed before inspection or maintenance of these machine.
- ② Make sure the above preventive measures are completed. A compressed air supply and the power supply to the machine must be off, and also the compressed air in the systems must be exhausted.
- ③ Restart the machines with care after ensuring to take all preventive measures against sudden movements.

Disclaimer

1. PISCO does not take any responsibility for any incidental or indirect loss, such as production line stop, interruption of business, loss of benefits, personal injury, etc., caused by any failure on use or application of PISCO products.
2. PISCO does not take any responsibility for any loss caused by natural disasters, fires not related to PISCO products, acts by third parties, and intentional or accidental damages of PISCO products due to incorrect usage.
3. PISCO does not take any responsibility for any loss caused by improper usage of PISCO products such as exceeding the specification limit or not following the usage the published instructions and catalog allow.
4. PISCO does not take any responsibility for any loss caused by remodeling of PISCO products, or by combinational use with non-PISCO products and other software systems.
5. The damages caused by the defect of Pisco products shall be covered but limited to the full amount of the PISCO products paid by the customer.



SAFETY INSTRUCTION MANUAL

PISCO products are designed and manufactured for use in general industrial machines. Be sure to read and follow the instructions below.

Danger

1. Do not use PISCO products for the following applications.
 - ① Equipment used for maintaining / handling human life and body.
 - ② Equipment used for moving / transporting human.
 - ③ Equipment specifically used for safety purposes.

Warning

1. Do not use PISCO products under the following conditions.
 - ① Beyond the specifications or conditions stated in the catalog, or the instructions.
 - ② Under the direct sunlight or outdoors.
 - ③ Excessive vibrations and impacts.
 - ④ Exposure / adhere to corrosive gas, inflammable gas, chemicals, seawater, water and vapor. *
* Some products can be used under the condition above(④), refer to the details of specification and condition of each product.
2. Do not disassemble or modify PISCO products, which affect the performance, function, and basic structure of the product.
3. Turn off the power supply, stop the air supply to PISCO products, and make sure there is no residual air pressure in the pipes before maintenance and inspection.
4. Do not touch the release-ring of push-in fitting when there is a working pressure. The lock may be released by the physical contact, and tube may fly out or slip out.
5. Frequent switchover of compressed air may generate heat, and there is a risk of causing burn injury.
6. Avoid any load on PISCO products, such as a tensile strength, twisting and bending. Otherwise, there is a risk of causing damage to the products.
7. As for applications where threads or tubes swing / rotate, use Rotary Joints, High Rotary Joints or Multi-Circuit Rotary Block only. The other PISCO products can be damaged in these applications.
8. Use only Die Temperature Control Fitting Series, Tube Fitting Stainless SUS316 Series, Tube Fitting Stainless SUS316 Compression Fitting Series or Tube Fitting Brass Series under the condition of over 60°C (140° F) water or thermal oil. Other PISCO products can be damaged by heat and hydrolysis under the condition above.
9. As for the condition required to dissipate static electricity or provide an antistatic performance, use EG series fitting and antistatic products only, and do not use other PISCO products. There is a risk that static electricity can cause system defects or failures.
10. Use only Fittings with a characteristic of spatter-proof such as Anti-spatter or Brass series in a place where flame and weld spatter is produced. There is a risk of causing fire by sparks.
11. Turn off the power supply to PISCO products, and make sure there is no residual air pressure in the pipes and equipment before maintenance. Follow the instructions below in order to ensure safety.
 - ① Make sure the safety of all systems related to PISCO products before maintenance.
 - ② Restart of operation after maintenance shall be proceeded with care after ensuring safety of the system by preventive measures against unexpected movements of machines and devices where pneumatic equipment is used.
 - ③ Keep enough space for maintenance when designing a circuit.
12. Take safety measures such as providing a protection cover if there is a risk of causing damages or fires on machine / facilities by a fluid leakage.

⚠ Caution

1. Remove dusts or drain before piping. They may get into the peripheral machine / facilities and cause malfunction.
2. When inserting an ultra-soft tube into push-in fitting, make sure to place an Insert Ring into the tube edge. There is a risk of causing the escape of tube and a fluid leakage without using an Insert Ring.
3. The product incorporating NBR as seal rubber material has a risk of malfunction caused by ozone crack. Ozone exists in high concentrations in static elimination air, clean-room, and near the high-voltage motors, etc. As a countermeasure, material change from NBR to HNBR or FKM is necessary. Consult with PISCO for more information.
4. Special option "Oil-free" products may cause a very small amount of a fluid leakage. When a fluid medium is liquid or the products are required to be used in harsh environments, contact us for further information.
5. In case of using non-PISCO brand tubes, make sure the tolerance of the outer tube diameter is within the limits of Table 1.

● Table 1. Tube O.D. Tolerance

mm size	Nylon tube	Polyurethane tube	inch size	Nylon tube	Polyurethane tube
ø1.8mm	—	± 0.05mm	ø1/8	± 0.1mm	± 0.15mm
ø3mm	—	± 0.15mm	ø5/32	± 0.1mm	± 0.15mm
ø4mm	± 0.1mm	± 0.15mm	ø3/16	± 0.1mm	± 0.15mm
ø6mm	± 0.1mm	± 0.15mm	ø1/4	± 0.1mm	± 0.15mm
ø8mm	± 0.1mm	± 0.15mm	ø5/16	± 0.1mm	± 0.15mm
ø10mm	± 0.1mm	± 0.15mm	ø3/8	± 0.1mm	± 0.15mm
ø12mm	± 0.1mm	± 0.15mm	ø1/2	± 0.1mm	± 0.15mm
ø16mm	± 0.1mm	± 0.15mm	ø5/8	± 0.1mm	± 0.15mm

6. Instructions for Tube Insertion

- ① Make sure that the cut end surface of the tube is at right angle without a scratch on the surface and deformations.
- ② When inserting a tube, the tube needs to be inserted fully into the push-in fitting until the tubing edge touches the tube end of the fitting as shown in the figure below. Otherwise, there is a risk of leakage.

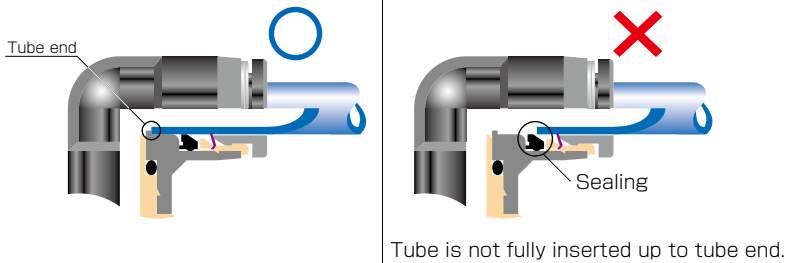

- ③ After inserting the tube, make sure it is inserted properly and not to be disconnected by pulling it moderately.
- ※ When inserting tubes, Lock-claws may be hardly visible in the hole, observed from the front face of the release-ring. But it does not mean the tube will surely escape. Major causes of the tube escape are the followings;
- ① Shear drop of the lock-claws edge
 - ② The problem of tube diameter (usually small)
- Therefore, follow the above instructions from ① to ③, even lock-claws is hardly visible.

7. Instructions for Tube Disconnection

- ① Make sure there is no air pressure inside of the tube, before disconnecting it.
- ② Push the release-ring of the push-in fitting evenly and deeply enough to pull out the tube toward oneself. By insufficient pushing of the release-ring, the tube may not be pulled out or damaged by scratch, and tube shavings may remain inside of the fitting, which may cause the leakage later.

8. Instructions for Installing a fitting

- ① When installing a fitting, use proper tools to tighten a hexagonal-column or an inner hexagonal socket. When inserting a hex key into the inner hexagonal socket of the fitting, be careful so that the tool does not touch lock-claws. The deformation of lock-claws may result in a poor performance of systems or an escape of the tube.
- ② Refer to Table 2 which shows the recommended tightening torque. Do not exceed these limits to tighten a thread. Excessive tightening may break the thread part or deform the gasket and cause a fluid leakage. Tightening thread with tightening torque lower than these limits may cause a loosened thread or a fluid leakage.
- ③ Adjust the tube direction while tightening thread within these limits, since some PISCO products are not rotatable after the installation.

● Table 2: Recommended tightening torque / Sealock color / Gasket materials

Thread type	Thread size	Tightening torque	Sealock color	Gasket materials
Metric thread	M3 × 0.5	0.7N·m	—	SUS304 NBR
	M5 × 0.8	1.0 ~ 1.5N·m		
	M6 × 1	2 ~ 2.7N·m		
	M3 × 0.5	0.5 ~ 0.6N·m		POM
	M5 × 0.8	1 ~ 1.5N·m		
	M6 × 0.75	0.8 ~ 1N·m		
Taper pipe thread	M8 × 0.75	1 ~ 2N·m	White	—
	R1/8	7 ~ 9N·m		
	R1/4	12 ~ 14N·m		
	R3/8	22 ~ 24N·m		
Unified thread	R1/2	28 ~ 30N·m	—	SUS304, NBR
	No.10-32UNF	1.0 ~ 1.5N·m		
National pipe thread taper	1/16-27NPT	7 ~ 9N·m	White	—
	1/8-27NPT	7 ~ 9N·m		
	1/4-18NPT	12 ~ 14N·m		
	3/8-18NPT	22 ~ 24N·m		
	1/2-14NPT	28 ~ 30N·m		

※ These values may differ for some products. Refer to each specification as well.

9. Instructions for removing a fitting

- ① When removing a fitting, use proper tools to loosen a hexagonal-column or an inner hex bolt.
- ② Remove the sealant stuck on the mating equipment. The remained sealant may get into the peripheral equipment and cause malfunctions.

10. Arrange piping avoiding any load on fittings and tubes such as twist, tensile, moment load, shaking and physical impact. These may cause damages to fittings, tube deformations, bursting and the escape of tubes.



Common Safety Instructions for Vacuum Series

Before selecting or using PISCO products, read the following instructions. Read the detailed instructions for individual series.

Warning

1. If there is a risk of dropping work-pieces during vacuum suction, take a safety measure against the falling of them.
2. Avoid supplying more than 0.1MPa pressure constantly in a vacuum circuit. Since vacuum generators are not explosive-proof, there is a risk of damaging the products.
3. Pay attention to drop of vacuum pressure caused by problems of the supplied air or the power supply. Decrease of suction force may lead to a danger of falling work-piece so that safety measure against the falling of them is necessary.
4. When more than 2 vacuum pads are plumbed on a single ejector and one of them has a suction problem such as vacuum leak, there is a risk of releasing work-pieces from the other pad due to the drop of the vacuum pressure.
5. Do not use in the way by which exhaust port is blocked or exhaust resistance is increased. Otherwise, there is a risk of no vacuum generation or a drop of the vacuum pressure.
6. Do not use the product in the circumstance of corrosive gas, inflammable gas, explosive gas, chemicals, seawater and vapor or do not expose the product to those. Never allow the product to suck those things.
7. Provide a protective cover on the products when it is exposed to sunlight.
8. Carry out clogging check for silencer element in an ejector and a vacuum filter periodically. Clogged element will be a cause to impair the performance or a cause of troubles.
9. Before replacing the element, thoroughly read and understand the method of filter replacement in the catalog.
10. Make sure the correct port of the vacuum generator by this catalog or marking on the products when plumbing. Wrong plumbing can be a risk to damage the product.
11. Supply clean air without sludge or dusts to an ejector. Do not lubricate by a lubricator. There is a risk of malfunction or performance impairing by impurities and oil contained in the compressed air.
12. Do not apply extreme tension, twist or bending forces on a lead wire. Otherwise, it may cause a wire breaking.
13. Locknut needs to be tightened firmly by hand. Do not use any tool to tighten. In case of using tools to tighten the locknut, it may damage the locknut or the product. Inadequate tightening may loosen the locknut and the initial setting can be changed.
14. Do not force the product to rotate or swing even its resin body is rotatable. It may cause damage to the product and a fluid leakage.
15. Do not supply an air pressure or a dry air to the products over the necessary amount. There is a risk of deteriorating rubber materials and malfunction due to oil.
16. Keep the product away from water, oil drops or dusts. These may cause malfunction. Take a proper measure to protect the product before the operation.

17. Do not use the product in the environment of inflammable or explosive gas / fluid. It can cause a fire or an explosion hazard.
18. Do not use the product in the circumstance of corrosive gas, inflammable gas, explosive gas, chemicals, seawater and vapor or do not expose the product to those. Otherwise, it may be a cause of malfunction.
19. Do not clean or paint the products by water or a solvent.

⚠ Caution

1. Operating pressure range in the catalog is the values during ejector operation. Secure the described value of the supplied air, taking a drop of the pressure into consideration. Insufficient pressure, which does not satisfy the spec, may cause abnormal noise, unstable performance and may negatively affect sensors, bringing troubles at last.
2. Effective cross-section area of the air supply side needs to be three times as large as effective cross-section area of the nozzle bore. When arranging piping or selecting PISCO products, secure required effective cross-section area. Insufficient supply pressure may be a cause to impair performance.
3. A Shorter distance of plumbing with a wider bore is preferable at vacuum system side. A long plumbing with a small bore may result in slow response time at the time of releasing work-piece as well as in failure to secure adequate suction flow rate.
4. Plumb a vacuum switch and an ejector with vacuum switch at the end of vacuum system as much as possible. A long distance between a vacuum switch and a vacuum system end may increase plumbing resistance which may lead to a high vacuum level at the sensor even when no suctioning and a malfunction of vacuum switch. Make sure to evaluate the products in an actual system.
5. Refer to "4. Instructions for Installing a fitting" and "5. Instructions for Removing a fitting" under "Common Safety Instructions for Fittings" , when installing or removing Fittings.
6. Refer to "Common Safety Instructions for Pressure Sensors" and "Detailed Safety Instructions" for the handling of digital vacuum switch sensor.
7. Refer to "Common Safety Instructions for Mechanical Vacuum Sensor" for the handling of mechanical vacuum switch.
8. The material of plastic filter cover for VG, VK, VJ, VZ and VX series is PCTG. Avoid the adherence of Chemicals below to the products, and do not use them under those chemical environments.

● Table Chemical Name

Chemical Name
Thinner
Carbon tetrachloride
Chloroform
Acetate
Aniline
Cyclohexane
Trichloroethylene
Sulfuric acid
Lactic acid
Water soluble cutting oil (alkaline)

* There are more chemicals which should be avoided. Contact us for the use under chemical circumstance.

VACUUM GENERATOR
EXTERNAL VACUUM CONTROLLER
VACUUM PAD
VACUUM ACCESSORIES
48
VH-VS
VU
VUM
VY
VB
VM-VC
VRL
VG
VK
VJ
VX
VQ
VZ
VN

9. The material of plastic filter cover for VQ and VFU series is PA. Avoid the adherence of chemicals below to the products, and do not use them under those chemical environments.

● Table Chemical Name

Chemical Name
Methanol
Ethanol
Nitric acid
Sulfuric acid
Hydrochloric acid
Lactic acid
Acetone
Chloroform
Aniline
Trichloroethylene
Hydrogen peroxide

* There are more chemicals which should be avoided. Contact us for the use under chemical circumstance.